



### Description

LMV321 (single channel) is a rail-to-rail input, output voltage feedback, low power consumption operational amplifier. It has wide input common mode voltage and output swing. The minimum working voltage can be up to 2.1V, and the maximum working voltage is recommended to be 5.5V. Used as power amplifier in all kinds of pocket or portable stereo radio recorders.

LMV321 has the following characteristics: Can provide 1MHz gain bandwidth product. It has an extremely low input bias current (about 10pA level) and can be used for integration, photo diode amplifiers and piezoelectric sensors. The Rail to Rail input and output buffers are also used for specific IC designs in single power systems. Applications of this series of amplifiers include safety monitoring, portable devices, batteries and power supplies, supply control, signal processing and interfaces in low power sensor systems.

### Features

- Rail to rail input and output, typical 0.8mv Vos
- Gain bandwidth product 1MHz
- Low input bias current: 10pA Level, <1nA
- Low Power consumption
- 2.1V ~ 5.5V working voltage
- Low operating current: 60uA

### Application

- ASIC input and output amplifier
- Sensor interface
- Piezoelectric sensing amplifier
- Battery-powered equipment
- The mobile communication
- Audio output

### SOT-23-5

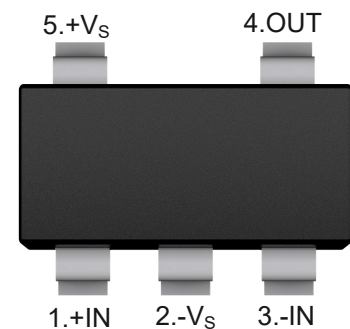

### Pin arrangement diagram

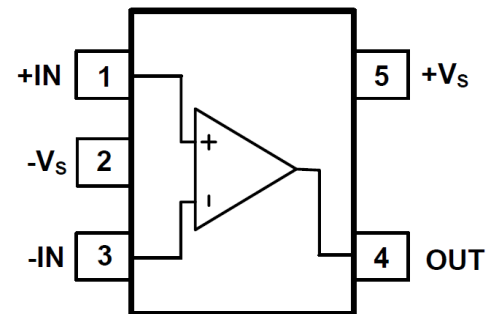



# LMV321

## Low-Power rail-to-rail Operational Amplifier

### Absolute Maximum Ratings (T<sub>A</sub>=25°C) <sup>Note1</sup>

Parameter	Symbol	Value	Units
Supply Voltage	V <sub>CC</sub>	7.5	V
Common-mode Input Voltage	V <sub>ICR</sub>	(-V <sub>S</sub> )-0.5~(+V <sub>S</sub> )0.5	V
Junction Temperature	T <sub>J</sub>	150	°C
Operating Temperature Range	T <sub>OPR</sub>	0 to 70	°C
Lead Temperature (Soldering, 10 sec)	T <sub>L</sub>	250	°C
Storage Temperature Range	T <sub>STG</sub>	-50 to 150	°C

Note1: Exceeding the above limits may damage to the chip. The reliability of the device will also be affected if the device works under the limit conditions. Electrostatic discharge can also cause damage to chips, so it is suggested to take some preventive measures for integrated circuits. Failure to follow proper handling and installation can also cause damage. Precision LMV321 and other devices are more vulnerable to damage than ordinary devices in the case of tiny electrostatic, and small parameter changes may make the whole circuit performance substandard.

### Electrical Characteristics

At R<sub>L</sub> = 100kΩ connected to V<sub>S</sub>/2, and V<sub>OUT</sub> = V<sub>S</sub>/2, T<sub>A</sub>=25°C), unless otherwise noted.

Parameter	Symbol	Conditions	Min.	Typ.	Max.	Units
Input Offset Voltage	V <sub>OS</sub>		--	±0.8	±5	mV
Input offset current	I <sub>OS</sub>		--	10	--	pA
Input bias current	I <sub>B</sub>		--	10	--	pA
Common-mode input voltage range	V <sub>CM</sub>	V <sub>S</sub> =5.5V	--	-0.1~5.6	--	V
Open-loop Gain	AOL	V <sub>O</sub> =0.1V to 4.9 V, R <sub>L</sub> =5 kΩ	70	80	--	dB
		V <sub>O</sub> =0.035V to 4.96 V, R <sub>L</sub> =100 kΩ	80	84	--	
Common Mode Rejection	CMRR	V <sub>CM</sub> = -0.1V~4 V, V <sub>S</sub> =5.5V	62	70	--	dB
		V <sub>CM</sub> = -0.1V~5.6 V, V <sub>S</sub> =5.5V	56	68	--	
Power Supply Rejection	PSRR	V <sub>CM</sub> = (-V <sub>S</sub> )+0.5 V, V <sub>S</sub> =2.5V~5.5V	60	80	--	dB
Input offset voltage drift	ΔV <sub>OS</sub> /ΔT		--	2.7	--	μV/°C
Input voltage swing	V <sub>I</sub>	R <sub>L</sub> = 100 kΩ	--	0.008	--	V
		R <sub>L</sub> =10 kΩ	--	0.08	--	V
Operating voltage range	V <sub>W</sub>		2.1	--	5.5	mV
Output Current	I <sub>O</sub>		20	23	--	mA
Quiescent Current	I <sub>Q</sub>	I <sub>OUT</sub> =0	--	60	80	μA
Slew Rate	SR	G = +1 , 2V Output Step	--	0.52	--	V/μs
Gain Bandwidth Product	GBP	CL = 100pF	--	1	--	MHz
Equivalent Input Noise Voltage	e <sub>N</sub>	f=1KHz	--	27	--	nV/√Hz
		f=10KHz	--	20	--	



### Typical Characteristic Curves

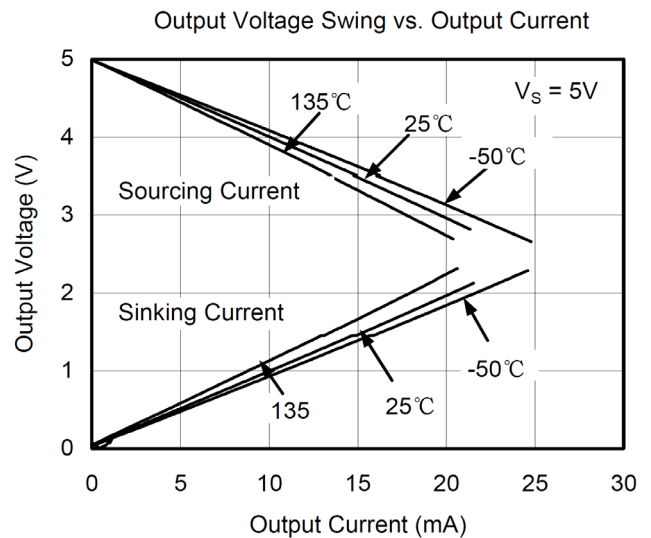
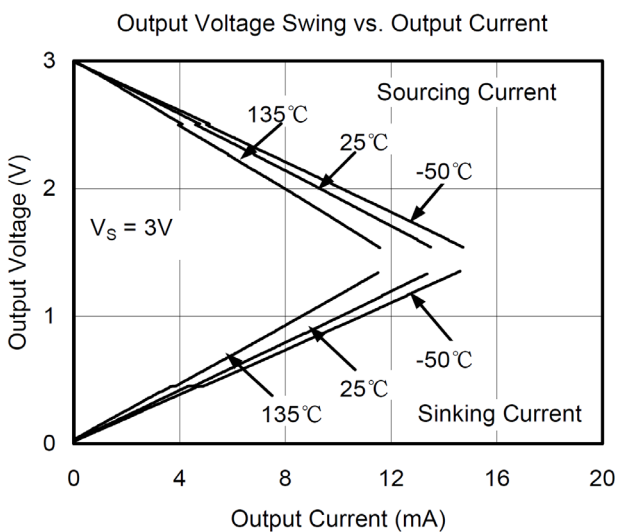
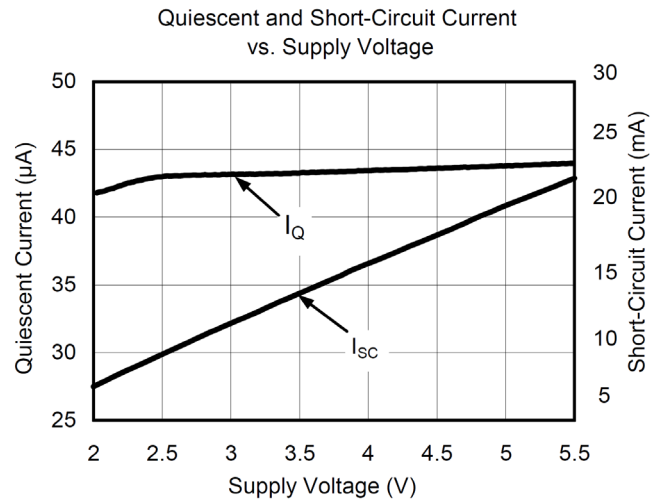
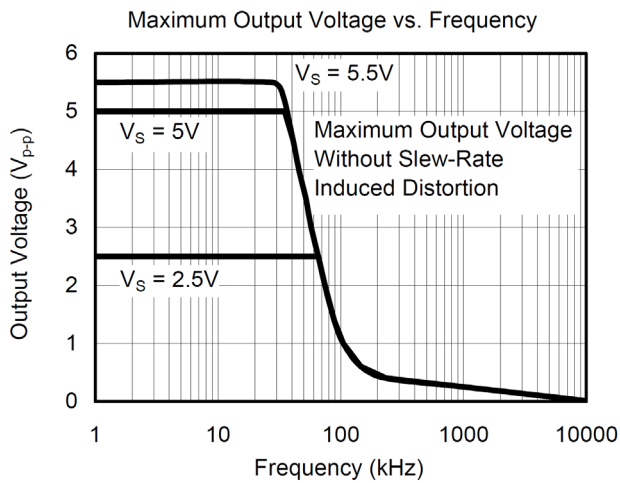
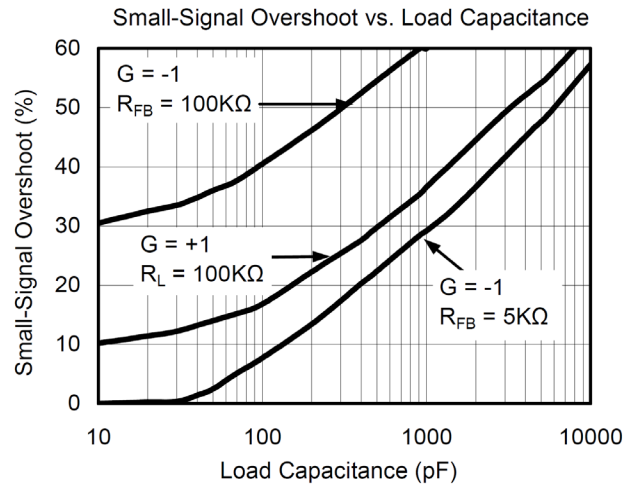
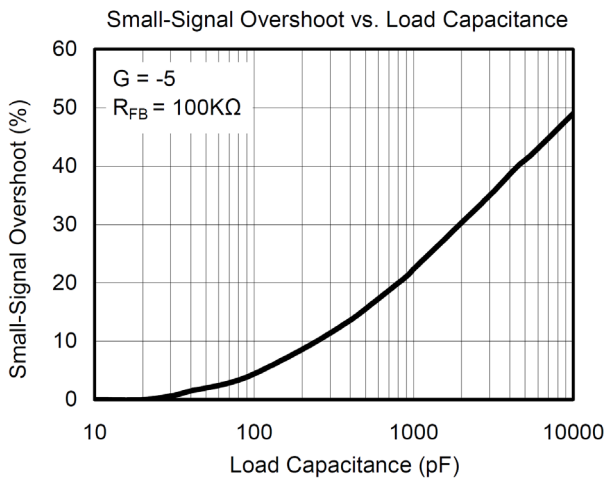

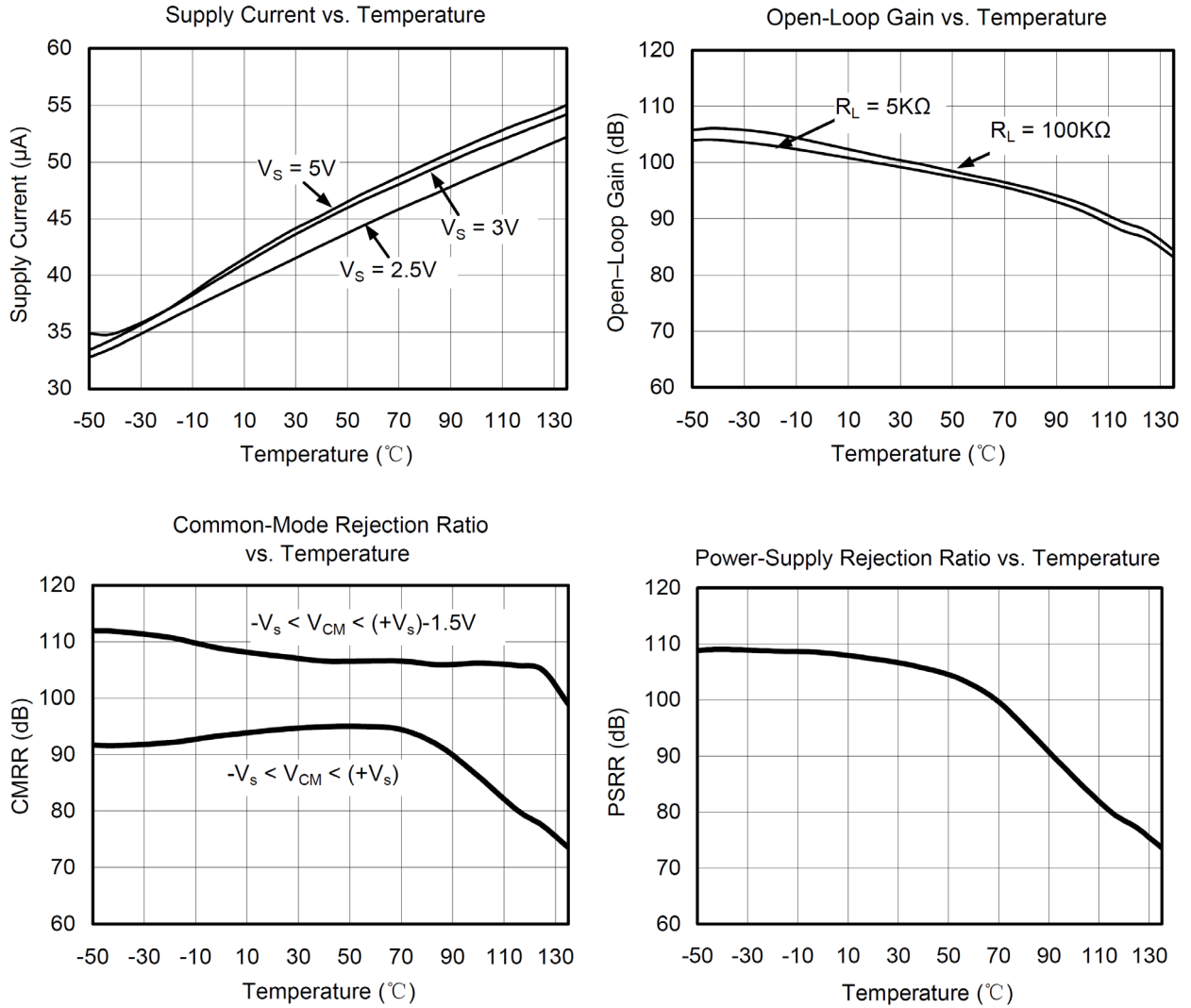

### Typical applications

#### 1. differential amplifier

As shown in the figure, if the resistance is equal, ( $R_4 / R_3 = R_2 / R_1$ ), then the output  $V_{OUT} =$

$$(V_p - V_n) \times R_2 / R_1 + V_{REF}$$

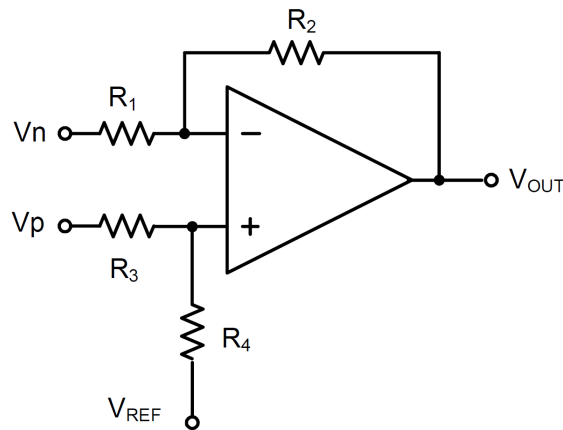



2. instrumentation amplifier

The circuit in the figure above performs the same function, but the input is high impedance.

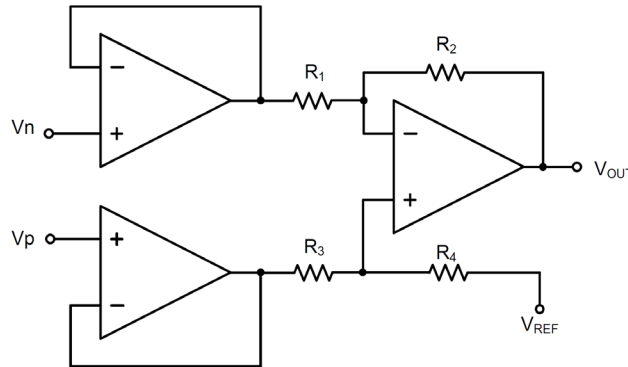

3. Low pass active filtering

The low-pass filter circuit shown here has a  $(-R_2 / R_1)$  DC gain and -3db at a frequency of  $1/2 \text{ PI R}2\text{C}$  corner. Make sure the filter is within the amplifier's bandwidth. Large feedback resistors are easily accompanied by parasitic capacitance at high speed, resulting in adverse effects such as oscillation. Keep the resistance value as low as possible and consider the appropriate output load.

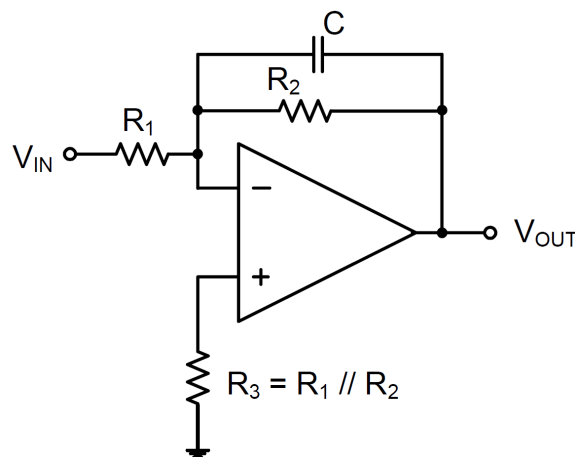



# LMV321

## Low-Power rail-to-rail Operational Amplifier

### Package Outline

SOT-23-5

Dimensions in mm

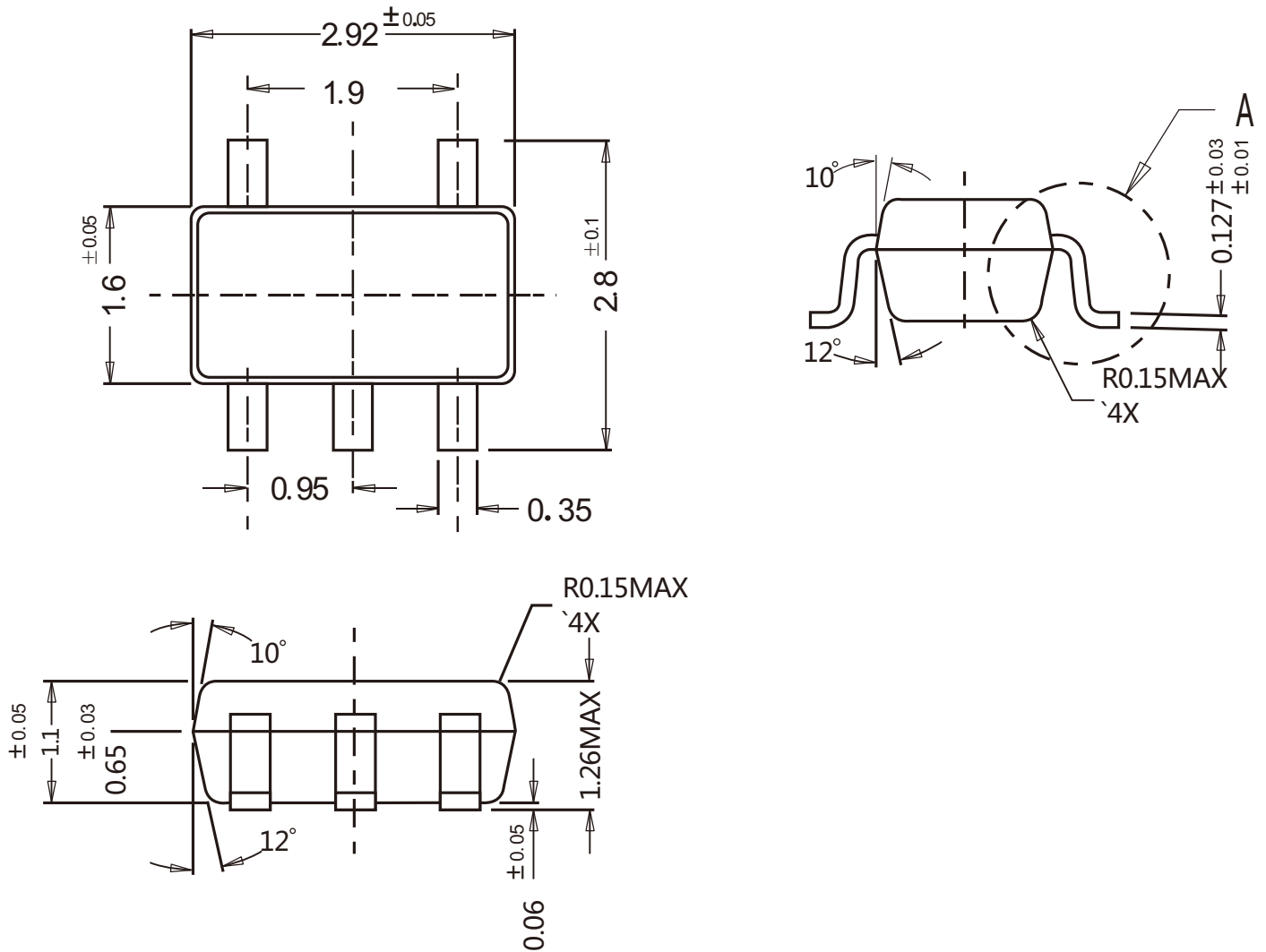

### Ordering Information

Device	Package	Shipping
LMV321	SOT-23-5	3,000/ Tape & Reel (7 inches)

## X-ON Electronics

Largest Supplier of Electrical and Electronic Components

*Click to view similar products for [Operational Amplifiers - Op Amps](#) category:*

*Click to view products by [Pingjingsemi](#) manufacturer:*

Other Similar products are found below :

[OPA2991IDSGR](#) [OPA607IDCKT](#) [007614D](#) [633773R](#) [635798C](#) [635801A](#) [702115D](#) [709228FB](#) [741528D](#) [NCV33072ADR2G](#)  
[SC2902DTBR2G](#) [SC2903DR2G](#) [SC2903VDR2G](#) [LM258AYDT](#) [LM358SNG](#) [430227FB](#) [430228DB](#) [460932C](#) [AZV831KTR-G1](#) [409256CB](#)  
[430232AB](#) [LM2904DR2GH](#) [LM358YDT](#) [LT1678IS8](#) [042225DB](#) [058184EB](#) [070530X](#) [SC224DR2G](#) [SC239DR2G](#) [SC2902DG](#)  
[SCYA5230DR2G](#) [714228XB](#) [714846BB](#) [873836HB](#) [MIC918YC5-TR](#) [TS912BIYDT](#) [NCS2004MUTAG](#) [NCV33202DMR2G](#)  
[M38510/13101BPA](#) [NTE925](#) [SC2904DR2G](#) [SC358DR2G](#) [LM358EDR2G](#) [AZV358MTR-G1](#) [AP4310AUMTR-AG1](#) [HA1630D02MMEL-E](#)  
[NJM358CG-TE2](#) [HA1630S01LPEL-E](#) [LM324AWPT](#) [HA1630Q06TELL-E](#)