



Description

The PJ4054E is a low cost, Single-cell, constant-current/constant-voltage Li-Ion battery charger. with a few external components, the PJ4054E is very small standalone charger for single lithium-ion batteries.

Charge current is set externally with a single resistor, no blocking diode is required due to the internal MOSFET architecture. The PJ4054E charges to a final float voltage accurate to $\pm 0.6\%$, The PJ4054E automatically terminates the charge cycle when the charge current drops to 1/10th the programmed value after the final float voltage is reached and automatically puts into a sleep mode while removing input power.

The output is both current and thermally protected to prevent operating outside of safe limits. UVLO, Thermal, OVP and reverse connection protection are also available.

Features

- Standalone Li-Ion Charger with Thermal Regulation
- Programmable Charge Current Up to 800mA
- No Sense Resistor or Blocking Diode Required
- Preset Charge Voltage with $\pm 0.6\%$ Accuracy
- Suitable for USB-Powered Charging
- 6.2V Input Over Voltage Protect
- C/10 Charge Termination
- 12V Absolute Maximum Input Voltage
- Low Battery Charging Conditioning
- Automatic Recharge
- Negligible Battery Drain Current in Shutdown
- Protection Against Battery Reverse Connection
- Self-protection for Overcurrent/Overtemperature
- Available in SOT-23-5 Package

Application

- Cellular Telephones
- Charging Docks and Cradles
- Handheld Computers
- Low Cost and Small Size Chargers

Typical Applications

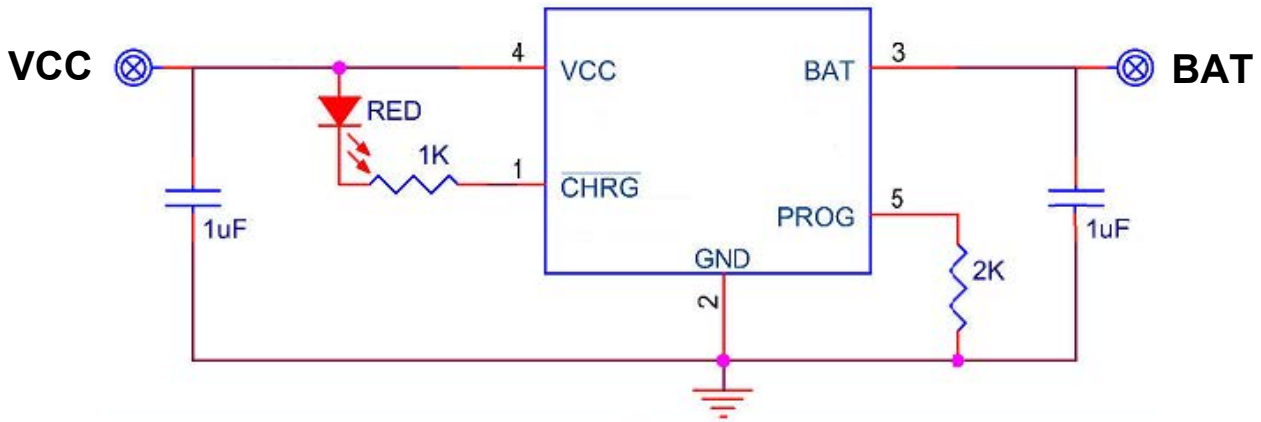

Pin Distribution

SOT-23-5

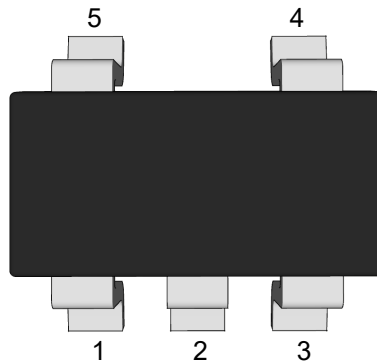

Pin Function

Pin No.	Symbol	Pin Function
1	CHRG	Open-Drain Charge Status Output.
2	GND	Ground Pin.
3	BAT	Charging Current Output.
4	VCC	Positive Input Vower Voltage.
5	PROG	Charge Current Program, Charge Current Monitor and Shutdown Pin.



PJ4054E

Linear Lithium-ion Battery Charger

Ordering Information

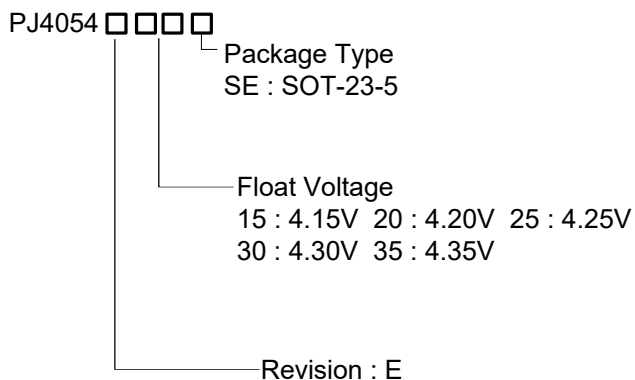

Orderable Device	Package	Reel (inch)	Package Qty (PCS)	Eco Plan ^{Note}	MSL Level	Marking Code
PJ4054E15SE	SOT-23-5	7	3000	RoHS & Green	MSL3	
PJ4054E20SE	SOT-23-5	7	3000	RoHS & Green	MSL3	
PJ4054E25SE	SOT-23-5	7	3000	RoHS & Green	MSL3	
PJ4054E30SE	SOT-23-5	7	3000	RoHS & Green	MSL3	
PJ4054E35SE	SOT-23-5	7	3000	RoHS & Green	MSL3	

Note:
 RoHS: PJ defines "RoHS" to mean semiconductor products that are compliant with the current EU RoHS requirements for all 10 RoHS substances, including the requirement that RoHS substance do not exceed 0.1% by weight in homogeneous materials.
 Green: PJ defines "Green" to mean Halogen-Free and Antimony-Free.

Block Diagram

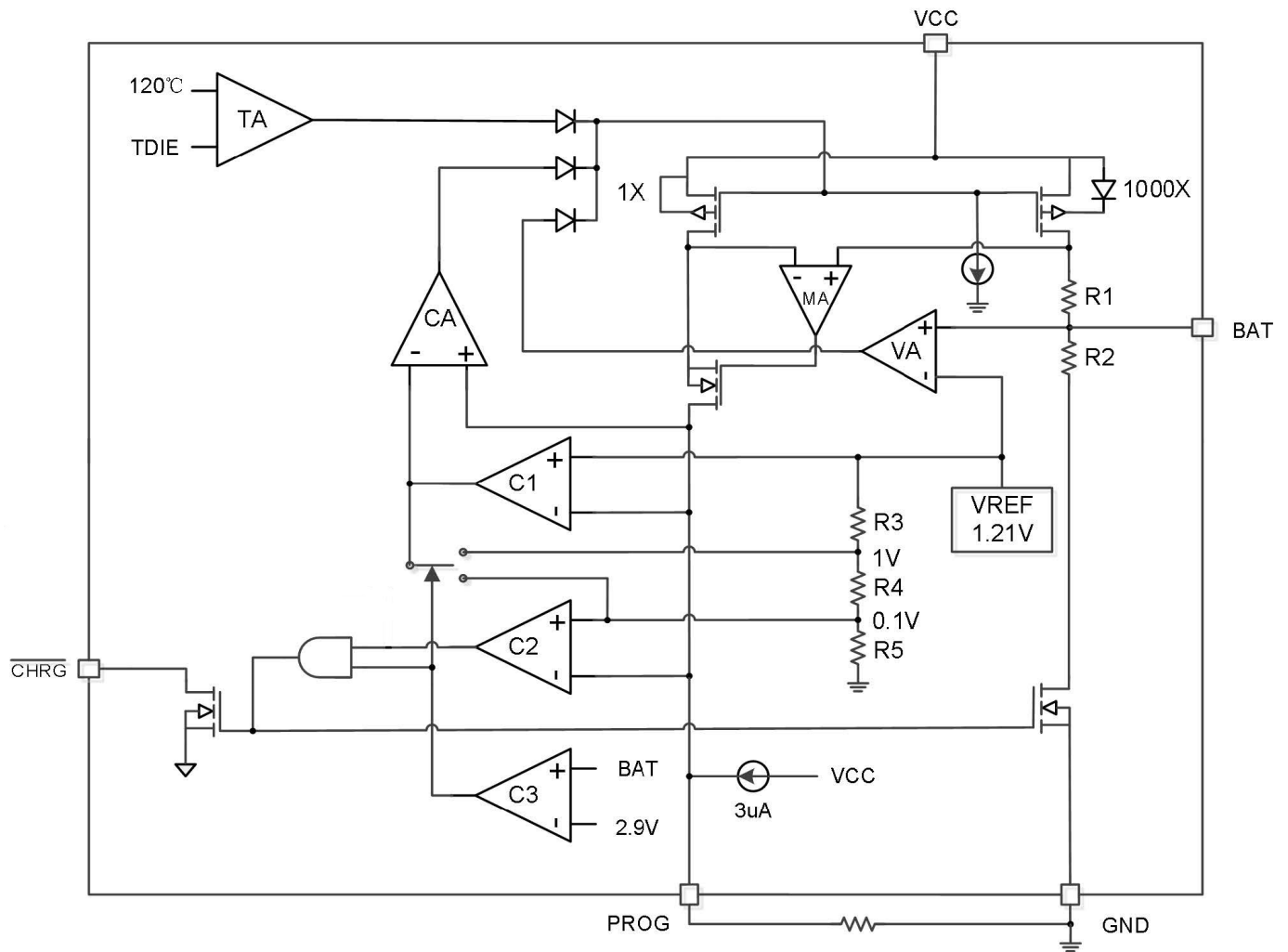

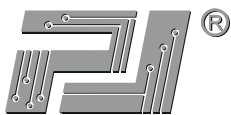

Absolute Maximum Ratings

Ratings at 25°C ambient temperature unless otherwise specified.

Parameter	Symbol	Ratings	Unit
VCC Input Voltage	V _{CC}	-0.3~12	V
Prog Pin Voltage	V _{PROG}	-0.3~8.5	V
CHG,BAT Pin Voltage	V _{BAT}	-4.5~5.5	V
Power Dissipation	P _D	0.6	W
Operating Junction Temperature Range	T _{OPR}	-40~+85	°C
Storage Temperature	T _{STG}	-55~+125	°C

Thermal Information

Parameter	Symbol	Ratings	Unit
Junction-to-Ambient Thermal Resistance	R _{θJA}	170	°C/W

Electrical Characteristics

(V_{IN}=5V, T_J=25°C, unless otherwise noted.)

Parameter	Symbol	Test Conditions	Min.	Typ.	Max.	Unit
Input Supply Voltage	V _{CC}		4.5	--	6.2	V
Input Supply Current	I _{CC}		--	150	--	μA
Regulated Output (Float) Voltage	V _{FLOAT}		-0.6	--	0.6	%
BAT Pin Current	I _{BAT}	R _{PROG} = 1.25K	700	800	900	mA
		R _{PROG} = 10K	90	100	110	mA
Trickle Charge Current	I _{TRIKL}	R _{PROG} = 1K	--	100	--	mA
		R _{PROG} = 10K	--	10	--	
Trickle Charge Threshold	V _{TRIKL}		--	2.9	--	V
C/10 Termination Current	I _{TERM}		8.5	10	11.5	%
PROG Pin Voltage	V _{PROG}		0.93	1.0	1.07	V
Recharge Battery Threshold	ΔV _{RECHG}		--	180	--	mV
CHRG Pin Weak Pull Down Current	I _{CHRG}		--	3	--	mA
PROG Pin Pull-Up Current	I _{PROG}		--	100	--	μA
RechargeComparat or Filter time	t _{RECHARGE}		--	2	--	mS
Soft-Start time	t _{SS}		--	100	--	μS
Junction Temperature in Constant Temperature Mode	T _{LIM}		--	120	--	°C
Power FET On resistance			--	600	--	mΩ



Typical Characteristics Curves

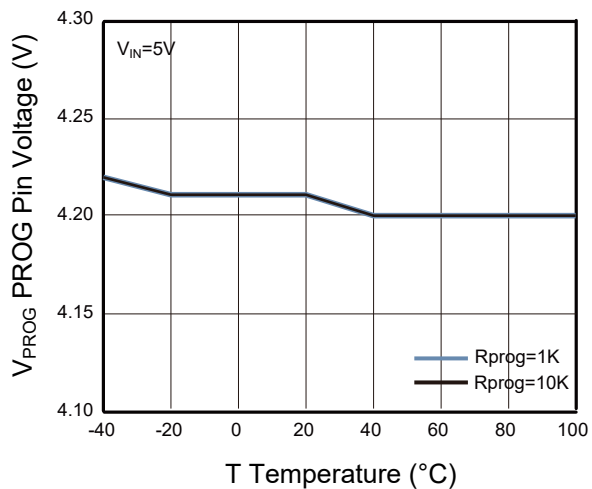
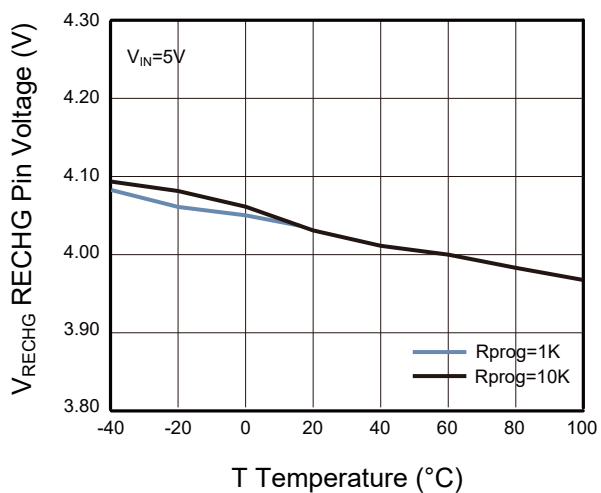
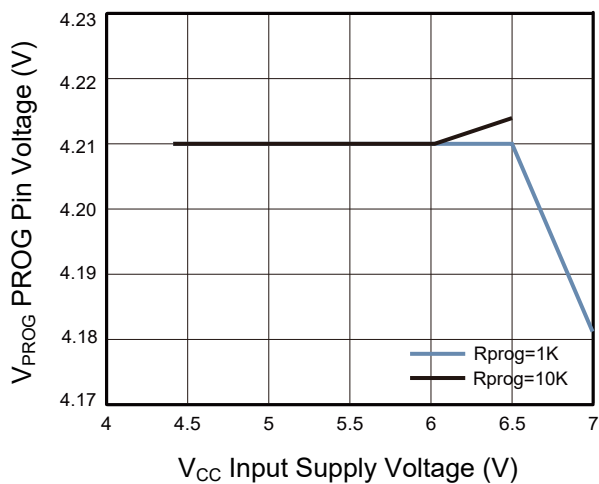
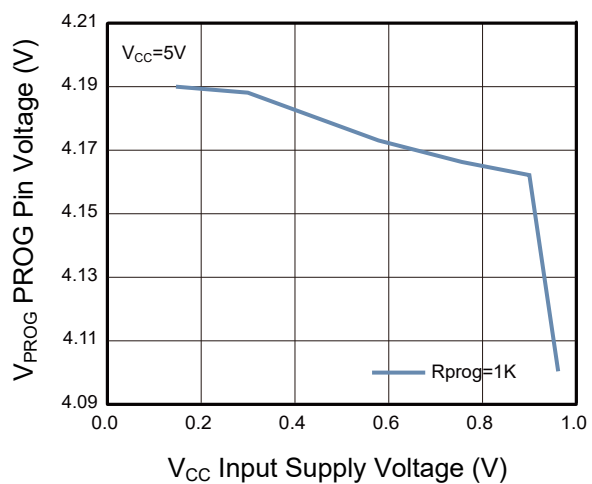
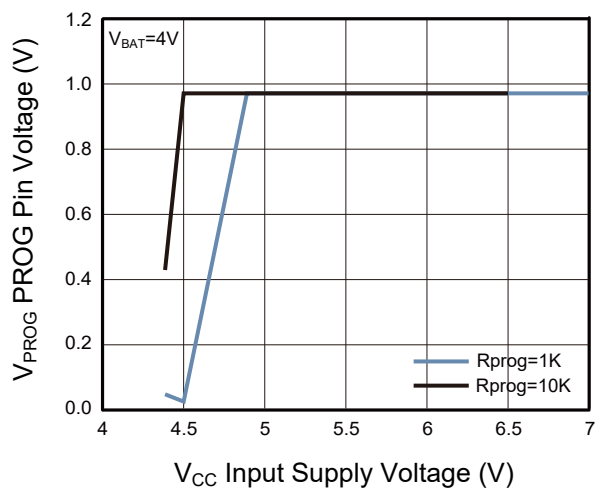
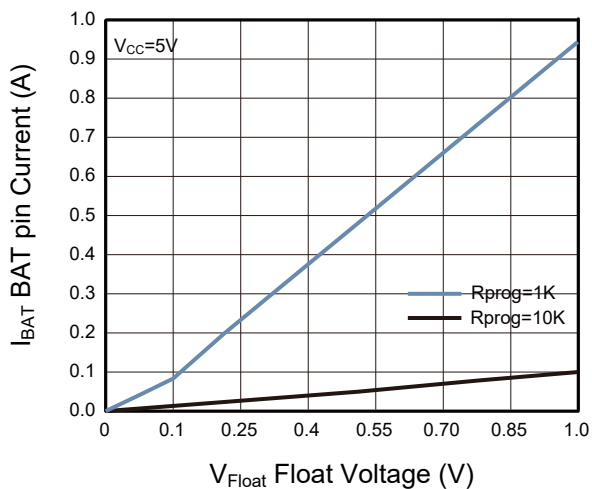

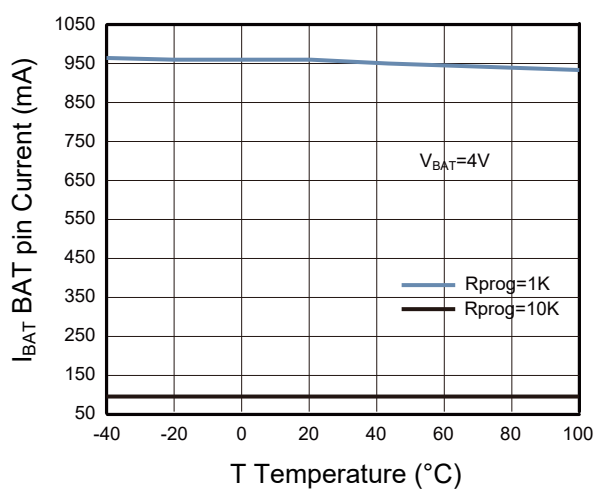
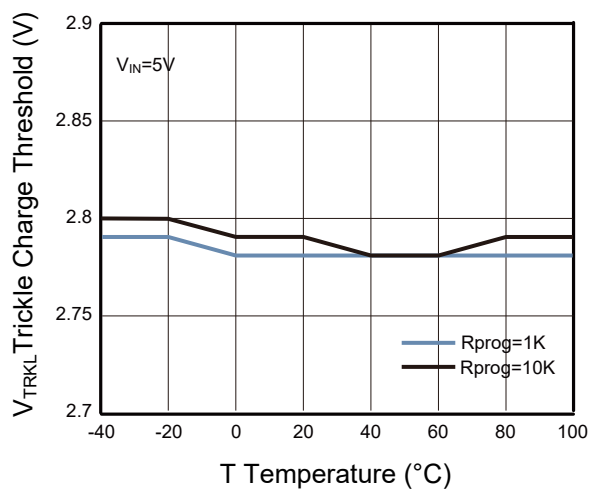
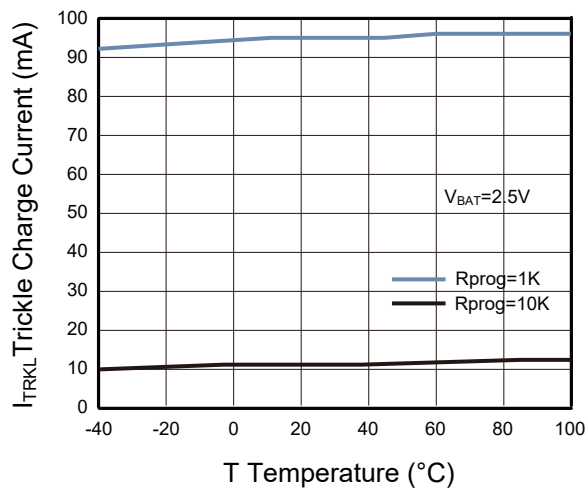
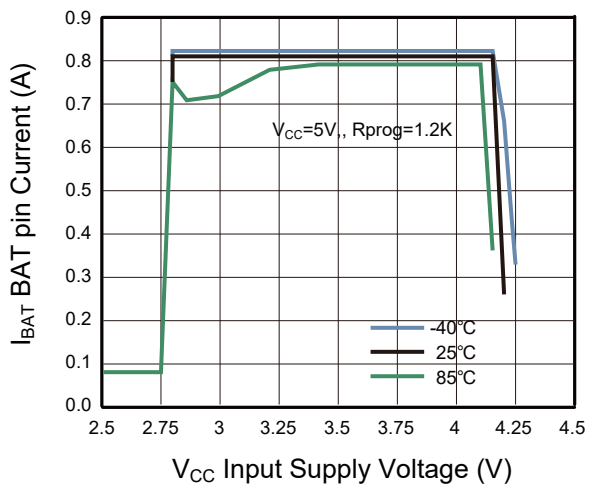
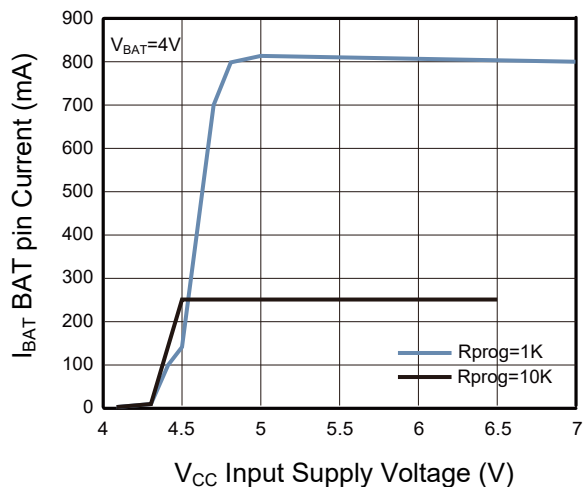
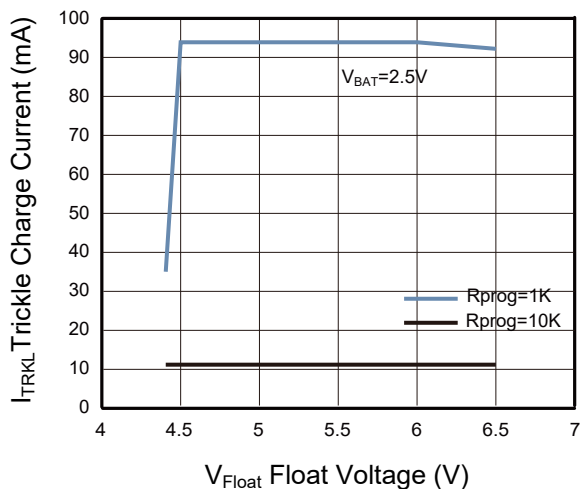



Operation

The PJ4054E is a single cell lithium-ion battery charger using a constant-current constant-voltage algorithm. It can deliver up to 800mA of charge current (using a good thermal PCB layout) with a final float voltage accuracy of $\pm 1\%$. The PJ4054E includes an internal P-channel power MOSFET and thermal regulation circuitry. No blocking diode or external current sense resistor is required; thus, the basic charger circuit requires only two external components. Furthermore, the PJ4054E is capable of operating from a USB power source.

Normal Charge Cycle

A charge cycle begins when the voltage at the VCC pin rises above the UVLO threshold level and a 1% program resistor is connected from the PROG pin to ground or when a battery is connected to the charger output. If the BAT pin is less than 2.9V, the charger enters trickle charge mode. In this mode, the PJ4054E supplies approximately 1/10 the programmed charge current to bring the battery voltage up to a safe level for full current charging. When the BAT pin voltage rises above 2.9V, the charger enters constant-current mode, where the programmed charge current is supplied to the battery. When the BAT pin approaches the final float voltage (4.2V), the PJ4054E enters constant-voltage mode and the charge current begins to decrease. When the charge current drops to 1/10 of the programmed value, the charge cycle ends.

Programming Charge Current

The charge current is programmed using a single resistor from the PROG pin to ground. The battery charge current is 1000 times the current out of the PROG pin. The program resistor and the charge current are calculated using the following equations:

$$R_{\text{PROG}} = \frac{1000V}{I_{\text{CHG}}} \qquad I_{\text{PROG}} = \frac{1000V}{R_{\text{PROG}}}$$

The charge current out of the BAT pin can be determined at any time by monitoring the PROG pin voltage using the following equation:

$$I_{\text{BAT}} = \frac{V_{\text{PROG}}}{R_{\text{PROG}}} \times 1000$$



Charge Termination

A charge cycle is terminated when the charge current falls to 1/10th the programmed value after the final float voltage is reached. This condition is detected by using an internal, filtered comparator to monitor the PROG pin. When the PROG pin voltage falls below 100mV for longer than 1ms, charging is terminated. The charge current is latched off and the PJ4054E enters standby mode, where the input supply current drops to 150µA. When charging, transient loads on the BAT pin can cause the PROG pin to fall below 100mV for short periods of time before the DC charge current has dropped to 1/10th the programmed value. The 1ms filter time on the termination comparator ensures that transient loads of this nature do not result in premature charge cycle termination. Once the average charge current drops below 1/10th the programmed value, the PJ4054E terminates the charge cycle and ceases to provide any current through the BAT pin. In this state, all loads on the BAT pin must be supplied by the battery. The PJ4054E constantly monitors the BAT pin voltage in standby mode. If this voltage drops below the 4.03V recharge threshold (VRECHRG), another charge cycle begins and current is once again supplied to the battery. To manually restart a charge cycle when in standby mode, the input voltage must be removed and reapplied, or the charger must be shut down and restarted using the PROG pin.

Charge Status Indicator

The CHRG charge status output has two different states: strong pull-down and high impedance. The CHRG strong pull-down state indicates that the PJ4054E is in a charge cycle. Once the charge cycle has terminated, the CHRG pin state is change to High impedance.

Charging Status	CHRG
Charging	Bright
Charge Complete	Snuffed Out
NO Battery	Flashing
Undervotagle	Snuffed Out
Reverse Battery Connection	Snuffed Out

Thermal Limiting

An internal thermal feedback loop reduces the programmed charge current if the die temperature attempts to rise above a preset value of approximately 120°C. This feature protects the PJ4054E from excessive temperature and allows the user to push the limits of the power handling capability of a given circuit board without risk of damaging the PJ4054E. The charge current can be set according to typical (not worst-case) ambient temperature with the assurance that the charger will automatically reduce the current in worst-case conditions.

Because of the small size of the SOT package, it is very important to use a good thermal PC board layout to maximize the available charge current. The thermal path for the heat generated by the IC is from the die to the copper lead frame, through the package leads, (especially the ground lead) to the PC board copper. The PC board copper is the heat sink. The footprint copper pads should be as wide as possible and expand out to larger copper areas to spread and dissipate the heat to the surrounding ambient. Feedthrough vias to inner or backside copper layers are also useful in improving the overall thermal performance of the charger. Other heat sources on the board, not related to the charger, must also be considered when designing a PC board layout because they will affect overall temperature rise and the maximum charge current.



PJ4054E

Linear Lithium-ion Battery Charger

Package Outline

SOT-23-5

Dimensions in mm

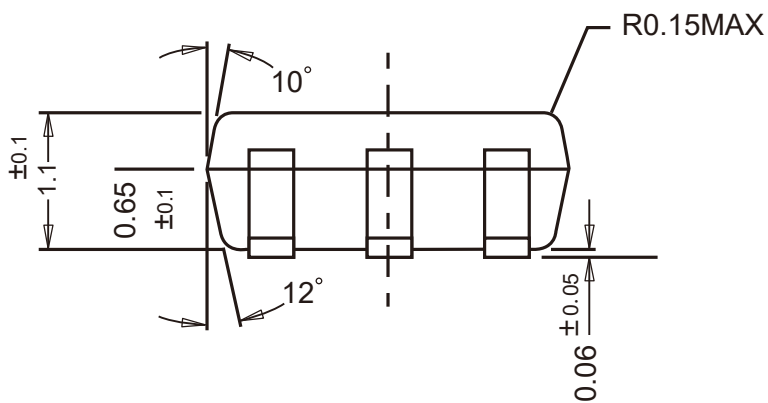
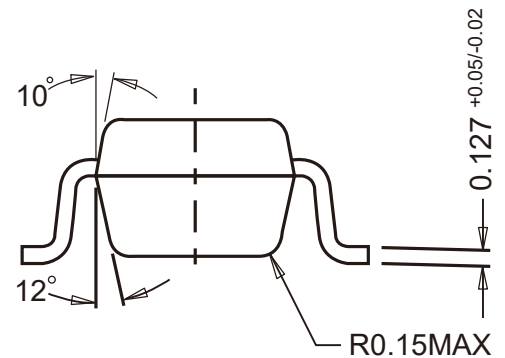
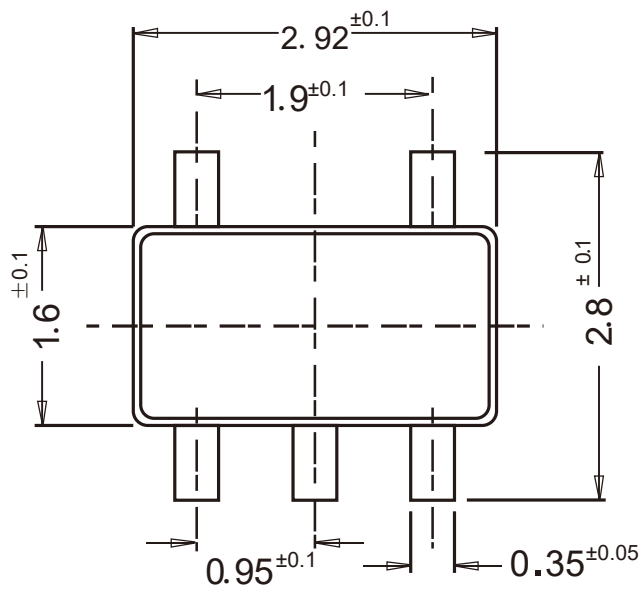

X-ON Electronics

Largest Supplier of Electrical and Electronic Components

Click to view similar products for [Battery Management](#) category:

Click to view products by [Pingjingsemi](#) manufacturer:

Other Similar products are found below :

[NCP1851BFCCT1G](#) [NCP1855FCCT1G](#) [FAN54063UCX](#) [MP2615GQ-P](#) [LC05132C01NMTTTG](#) [ISL95522HRZ](#) [BD8665GW-E2](#)
[ISL95522AIRZ](#) [S-82D1AAE-A8T2U7](#) [S-82D1AAA-A8T2U7](#) [S-8224ABA-I8T1U](#) [MP2615CGQ-P](#) [ISL6251HRZ](#) [ISL6253HRZ](#) [ISL6292-2CR3](#) [ISL6292BCRZ-T](#) [ISL6299AIRZ](#) [ISL9211AIRU58XZ-T](#) [ISL9214IRZ](#) [ISL9220IRTZ-T](#) [FAN54161UCX](#) [DW01-A/J](#) [DW01A](#) [4056H](#)
[4056D](#) [TP4056](#) [TP4054](#) [TP4057](#) [IP2326_NPD](#) [IP2709_BF20WP](#) [TP4057](#) [TP4054](#) [TP4056-MS](#) [TP4057-MS](#) [TP4054-MS](#) [SY6982CQDC](#)
[SLM6335](#) [SLM6500S](#) [TP4057](#) [DW01](#) [AP5056HSPER](#) [EG4321](#) [GN4054B](#) [HG4054M5/TR](#) [4060](#) [4061](#) [4061H](#) [4056A](#) [4056V](#) [4060H](#)