



PJ5102SG Dual USB Dedicated Charging Port Controller

Description

The PJ5102SG is a Dual USB dedicated charging port controller. An auto -detect feature monitors USB data line voltage, and automatically provides the correct electrical signatures on the data lines to charge compliant devices among the following dedicated charging schemes:

- 1、 Divider DCP, required to apply 2 V and 2.7 V on the D+ and D- Lines respectively
- 2、 BC1.2 DCP, required to short the D+ Line to the D- Line
- 3、 Chinese Telecom Standard YD/T 1591-2009 Shorted Mode, required to short the D+ Line to the D- Line
- 4、 1.2 V on both D+ and D- Lines

Features

- Supports USB DCP Shorting D+ Line to D- Line per USB Battery Charging Specification, Revision 1.2 (BC1.2)
- Supports Shorted Mode (Shorting D+ Line to D-Line) per Chinese Telecommunication Industry Standard YD/T 1591-2009
- Supports USB DCP Applying 2.7 V on D+ Line and 2.7 V on D- Line
- Supports USB DCP Applying 1.2 V on D+ and D- Lines
- Automatically Switch D+ and D- Lines Connections for an Attached Device
- Operating Range: 4.5 V to 5.5 V
- Available in SOT-23-6 Package

Applications

- Car Charger
- Vehicle USB Power Chargers Networking Systems
- Other USB Chargers

Typical Application

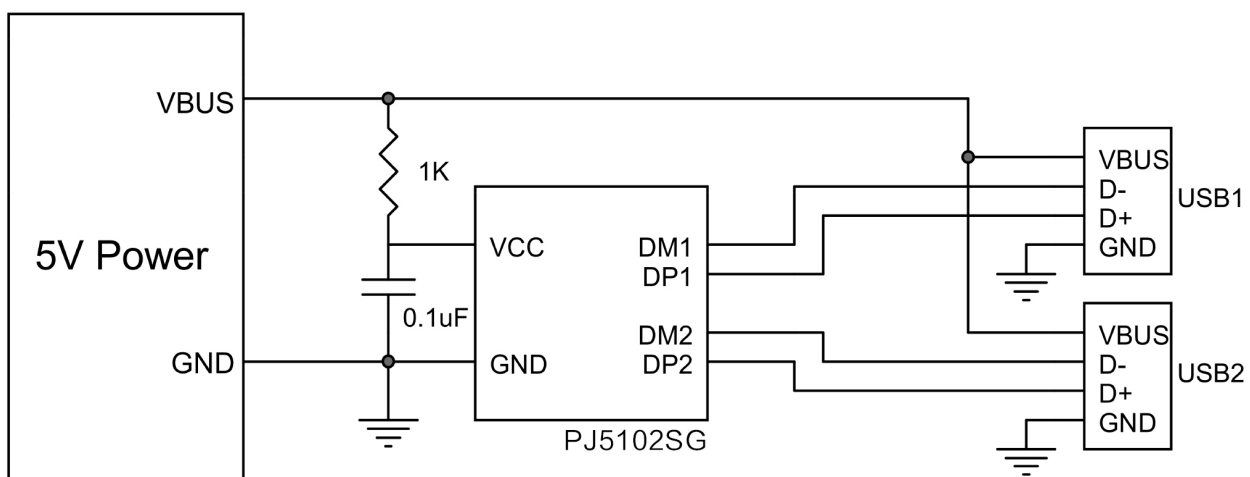



Pin Function And Descriptions

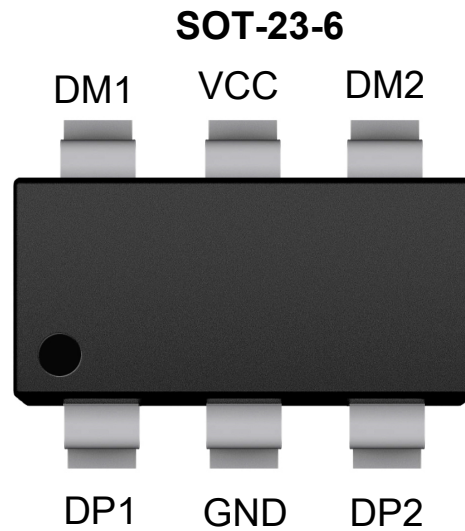

PIN	NAME	DESCRIPTION
1	DP1	Connected to the D+ line of USB connector
2	GND	Ground
3	DP2	Connected to the D+ line of USB connector
4	DM2	Connected to the D- line of USB connector
5	VCC	Power supplier
6	DM1	Connected to the D-line of USB connector

Block Diagram

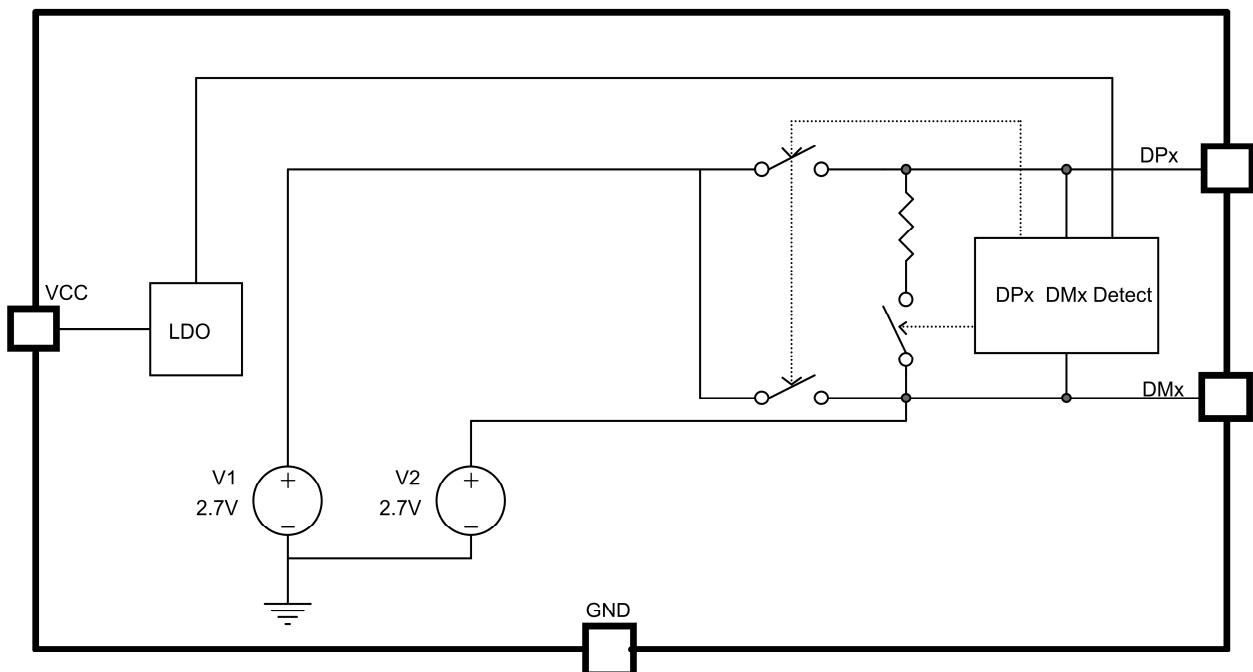



Absolute Maximum Ratings (at TA = 25°C)

Characteristics	Symbol	Rating	Unit
VIN to GND		-0.3 to 7	V
DP1,DM1,DP2,DM2 to GND		-0.3 to +6	V
Operating Junction Temperature		-40 to 125	°C
Storage Junction Temperature		-55 to 150	°C
Junction to Ambient Thermal Resistance	R θ JA	180	°C/W
Junction to board thermal resistance	R θ JB	120	°C/W
Junction to case thermal resistance	R θ JC	42	°C/W

ESD Ratings

		Value	Unit
Electrostatic discharge	Human-body model (HBM)	± 8000	V

Recommended Operating Conditions

	Symbol	MIN	MAX	Unit
Input voltage of VCC	VCC	4.5	5.5	V
DP1,DP2 data line input voltage	VDP	0	5.5	V
DM1,DM2 data line input voltage	VDM	0	5.5	V
DP1,DP2 Continuous sink or source current	IDP	0	± 10	mA
DM1,DM2 Continuous sink or source current	IDM	0	± 10	mA



PJ5102SG

Dual USB Dedicated Charging Port Controller

Electrical Characteristics

$T_J = 25^{\circ}\text{C}$. VCC = 5V, unless otherwise noted

Characteristics	Symbol	Conditions	Min.	Typ.	Max.	Units
Input Voltage	VCC		4.3	5	5.5	V
UVLO Voltage	V_{UVLO}		3.1	3.7	4.3	V
UVLO Hysteresis				0.1		V
Quiescent Current	I_{CCQ}	VCC=5V		220		μA
BC 1.2 DCP Mode						
DP,DM Short Resistance	R_{DPM}			160	200	Ω
Resistance between DPX and GND	R_{DPG}	$V_{DPx}=0.8\text{V}$		650	1000	K Ω
Resistance between DMX and GND	R_{DMG}	$V_{DMx}=0.8\text{V}$		650	1000	K Ω
DPx threshold of Goes to divider mode	V_{DPx_TH}			300		mV
Divider Mode						
DPx output voltage	$V_{DPx_2.7}$		2.6	2.7	2.8	V
DMx output voltage	$V_{DMx_2.0}$		2.6	2.7	2.8	V
DPx output impedance	R_{DPX}		24	30	36	K Ω
DMx output impedance	R_{DMX}		24	30	36	K Ω
1.2V /1.2V Mode						
DPX output voltage	$V_{DPX_1.2}$		1.12	1.2	1.28	V
DMX output voltage	$V_{DMX_1.2}$		1.12	1.2	1.28	V

Note: DPX Stands for DP1 or DP2, DMX Stands for DM1 or DM2



PJ5102SG

Dual USB Dedicated Charging Port Controller

Package Outline

SOT-23-6

Dimensions in mm

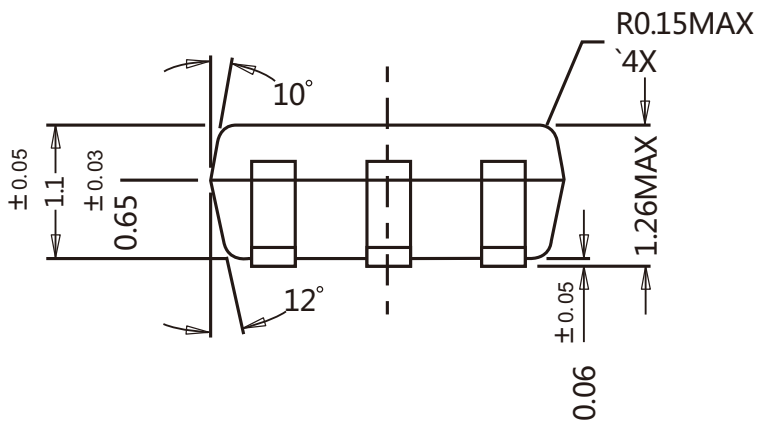
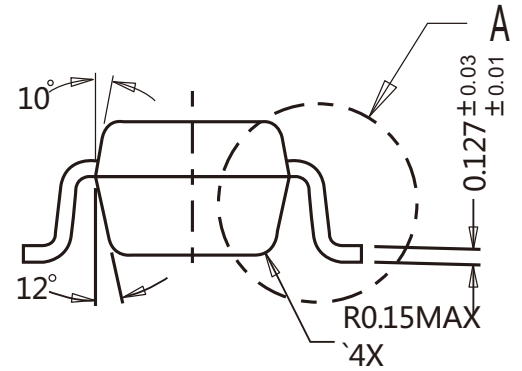
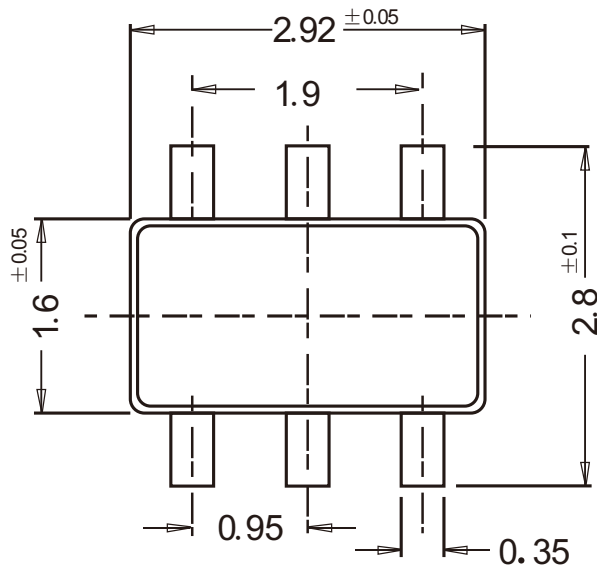

Ordering Information

Device	Package	Shipping
PJ5102SG	SOT-23-6	3,000/ Tape & Reel (7 inches)

X-ON Electronics

Largest Supplier of Electrical and Electronic Components

Click to view similar products for [USB Interface IC](#) category:

Click to view products by [Pingjingsemi](#) manufacturer:

Other Similar products are found below :

[TUSB1146RNQT](#) [TUSB1146IRNQT](#) [CY7C65210-24LTXI](#) [CY7C69356-48LTXC](#) [CYUSB2304-68LTXI](#) [CY7C65642-48AXCT](#) [CYPD2119-24LQXI](#) [USB2227-NU-11](#) [USB2251-NU-06](#) [USB3319C-GJ-TR](#) [USB3370B-EZK-TR](#) [USB5537B-4100AKZE](#) [USB3347-CP](#) [USB2230-NU-02](#) [USB2229-NU-02](#) [CG7648AM](#) [W83627HG-AW](#) [CY7C64225-28PVXCT](#) [CY7C65215A-32LTXI](#) [CYPD2120-24LQXI](#) [CYWB0164BB-BZXI](#) [CYWB0224ABS-BZXI](#) [CY7C65211A-24LTXI](#) [USB5807T-I/KD](#) [USB5742-I/2G](#) [USB3331E-GL-TR](#) [USB3321C-GL-TR](#) [USB1T1103MHX](#) [USB1T1103MPX](#) [USB5742/2G](#) [MAX3301EETJ+T](#) [CYPD2122-20FNXIT](#) [CYPD2122-24LQXIT](#) [LIF-UC120-SWG36ITR50](#) [MAX3456EETE+T](#) [LIF-UC120-CM36ITR50](#) [UPD360-C/6HX](#) [USB2228-NU-11](#) [UPD360-B/6HX](#) [PI3EQX7841ZDEX](#) [CYPD4225-40LQXI](#) [LAN7800-I/VSX](#) [UPD360T-B/6HX](#) [UPD360-A/6HX](#) [LAN7800/VSX](#) [MAX20037ATIB/V+](#) [MP5030CGQH-P](#) [USB7056/KDX](#) [STUSBCD01BJR](#) [CY7C65642-28LTXCT](#)