



Description

The PJ54A Series is a high input voltage, low quiescent current, low-dropout linear regulator able to provide 300mA load current.

The LDO features very fast response against line voltage transient and load current transient, and ensures no overshoot voltage during the LDO start up and short circuit recovery.

The device features integrated short-circuit and thermal shutdown protection.

Features

- Low Quiescent Current: 2.1uA
- High Input Voltage Rating: Up to 55V
- Maximum Output Current: 350mA
- Low Dropout : 350mV @ 100mA
- High PSRR: 85dB at 1KHz
- Fixed Output Voltages: 1.8V, 3V, 3.3V, 5V
- Fast Transient Response
- Current Limiting Protection
- Thermal Shutdown Protection
- Available Packages: SOT-23, SOT-23-3, SOT-89

Applications

- Battery-Powered Equipment
- Smoke Detector and Sensor
- Micro Controller Applications

Typical Application Circuit

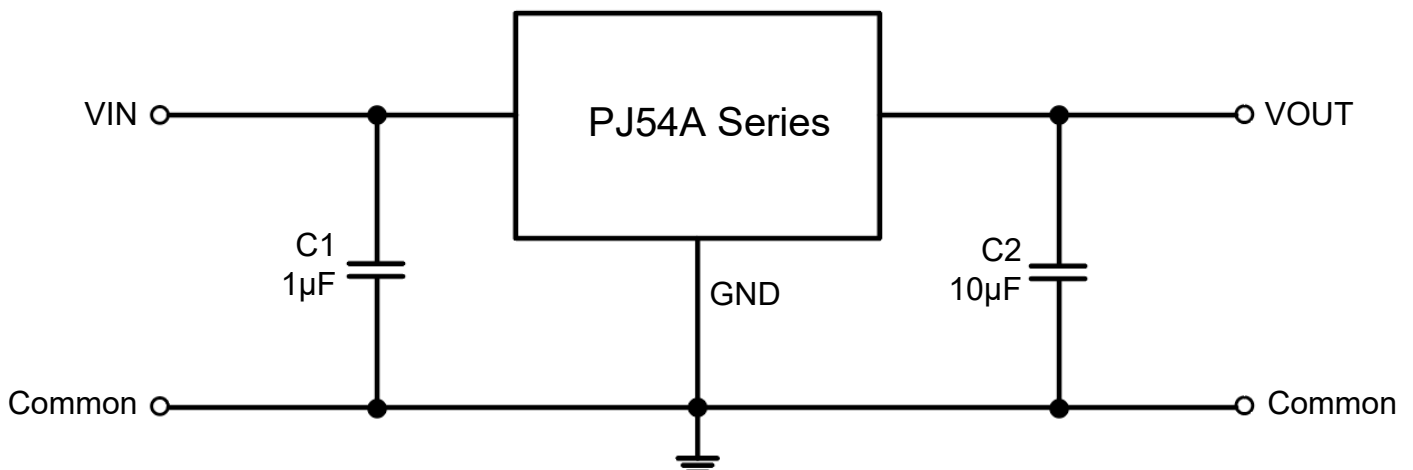

Pin Distribution

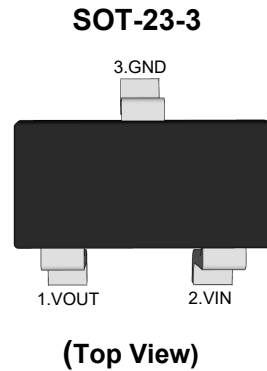
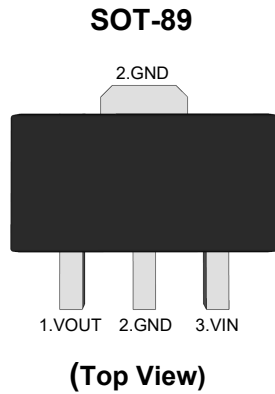
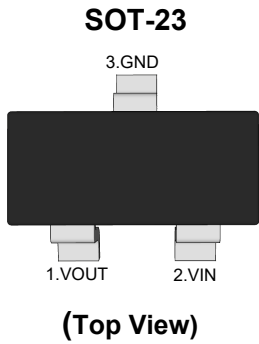

Functional Pin Description

Pin Name	Pin Function
GND	Ground
VOUT	Output Voltage
VIN	Power Input Voltage

Ordering Information

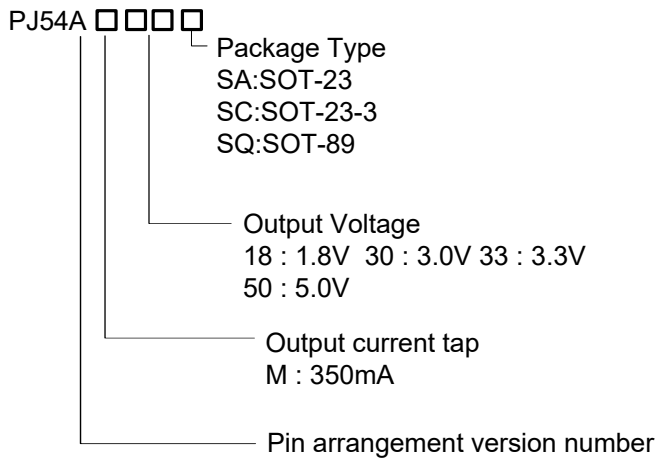

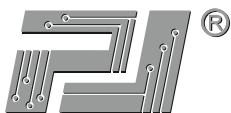

PJ54A Series Low Dropout Regulators

Ordering Information Continue

Orderable Device	Package	Reel (inch)	Package Qty (PCS)	Eco Plan ^{Note}	MSL Level	Marking Code
PJ54AM18SA	SOT-23	7	3000	RoHS & Green	MSL1	 XX:Output Voltage e.g. 30:3.0V
PJ54AM30SA						
PJ54AM33SA						
PJ54AM50SA						
PJ54AM18SQ	SOT-89	7/13	1000/3000	RoHS & Green	MSL1	 XX:Output Voltage e.g. 30:3.0V
PJ54AM30SQ						
PJ54AM33SQ						
PJ54AM50SQ						
PJ54AM18SC	SOT-23-3	7	3000	RoHS & Green	MSL3	 XX:Output Voltage e.g. 30:3.0V
PJ54AM30SC						
PJ54AM33SC						
PJ54AM50SC						

Note:

RoHS: PJ defines "RoHS" to mean semiconductor products that are compliant with the current EU RoHS requirements for all 10 RoHS substances, including the requirement that RoHS substance do not exceed 0.1% by weight in homogeneous materials.

Green: PJ defines "Green" to mean Halogen-Free and Antimony-Free.

Function Block Diagram

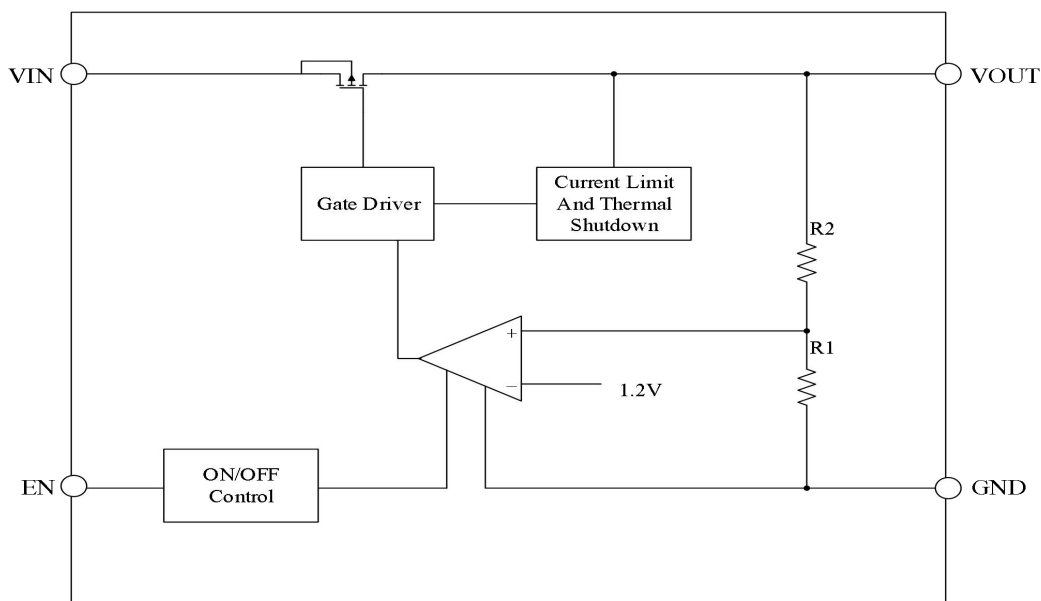

Absolute Maximum Ratings

Ratings at 25°C ambient temperature unless otherwise specified.

Parameter	Value	Unit
VIN to GND Voltage	-0.3 ~ +55	V
VOUT to GND Voltage	-0.3 ~ +6	V
VOUT to VIN Voltage	-55 ~ +0.3	V
EN to GND Voltage	-0.3 ~ +55	V
Output Current	Internally limited	--
Power Dissipation	SOT-23	300
	SOT-23-3	400
	SOT-89	600
Thermal Resistance, Junction-to-Ambient	SOT-23	380
	SOT-23-3	300
	SOT-89	180
Operating Ambient Temperature	-40 ~ +85	°C
Junction temperature	150	°C
Storage temperature range	-40 ~ +150	°C
ESD(HBM)	4	KV



Electrical Characteristics

($V_{IN}=V_{OUT}+1$, $C_{IN}=1\mu F$, $C_{OUT}=10\mu F$, $T_A=25^\circ C$, unless otherwise noted.)

Parameter	Symbol	Test Conditions	Min.	Typ.	Max.	Unit
Input Voltage	V_{IN}		3	--	45	V
Output Voltage Accuracy	ΔV_{OUT}	$V_{IN}=12V$, $I_{OUT}=10mA$	-2	--	+2	%
Quiescent Current	I_Q	$V_{IN}=12V$, $I_{OUT}=0mA$	--	2.1	--	μA
Maximum Output Current	I_{OUT_Max}		300	350	--	mA
Dropout Voltage	V_{DROP}	$V_{IN}=V_{OUTNOM}-0.1V$, $I_{OUT}=10mA$	--	35	--	mV
		$V_{IN}=V_{OUTNOM}-0.1V$, $I_{OUT}=100mA$	--	350	--	
Line Regulation	ΔV_{LINE}	$V_{OUTNOM}+0.5V \leq V_{IN} \leq 40V$ $I_{OUT}=1mA$	--	0.01	--	%/V
Load Regulation	ΔV_{LOAD}	$V_{IN}=12V$, $1mA < I_{OUT} < 100mA$	--	0.02	--	%/mA
Current Limit	I_{LIM}		--	500	--	mA
EN Input Threshold	Logic Low	V_{IL}	--	--	0.4	V
	Logic High	V_{IH}	1	--	--	V
Power Supply Rejection Ratio	PSRR	$V_{IN}=12V$, $I_{OUT}=10mA$ $f=1KHz$, $V_{OUT}=3.3V$	--	85	--	dB
Thermal Shutdown Temperature	T_{SHDN}	Shutdown, Temp increasing	--	150	--	$^\circ C$
Thermal Reset Temperature	T_{SHDN}	Reset, Temp increasing	--	140	--	$^\circ C$



PJ54A Series Low Dropout Regulators

Typical Characteristic Curves

(Test Condition: $T_A=25^{\circ}\text{C}$, $I_{\text{OUT}}=1\text{mA}$, $C_{\text{OUT}}=10\mu\text{F}$, unless otherwise noted.)

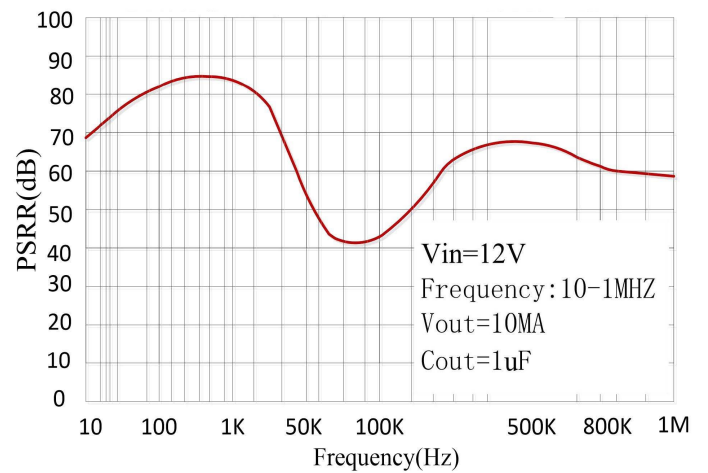
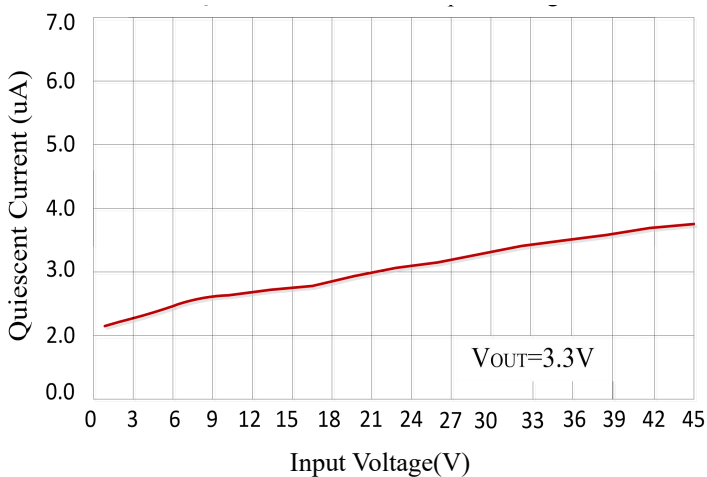
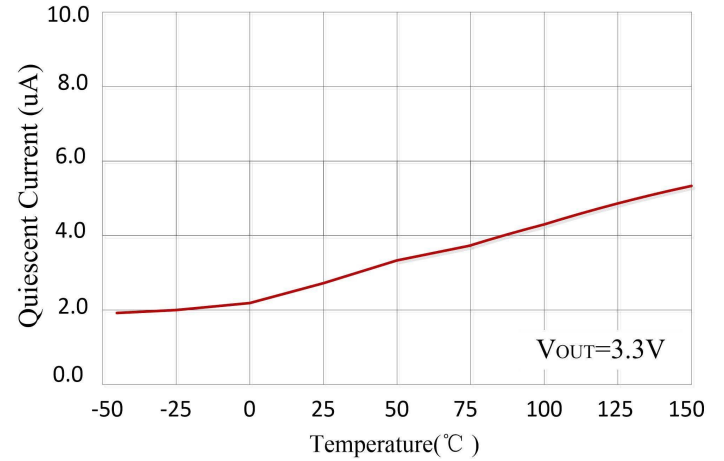
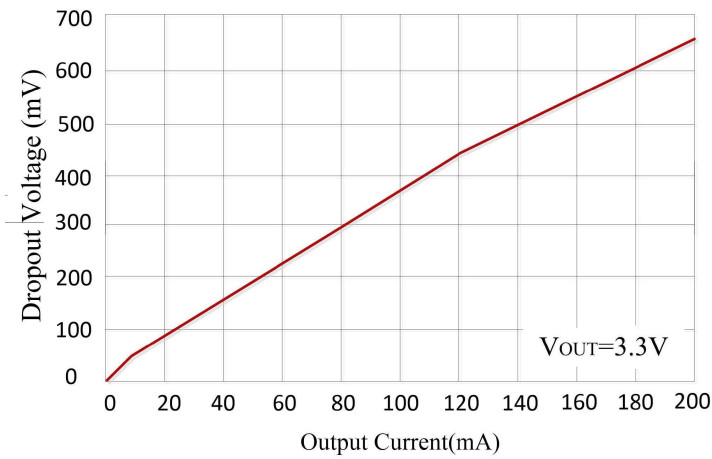
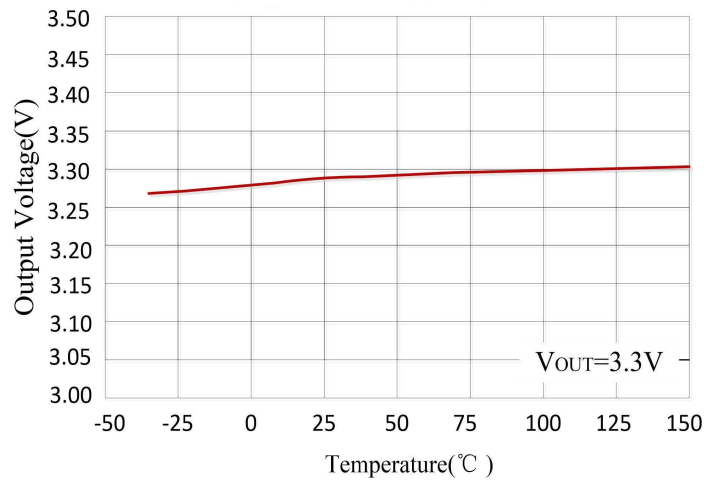
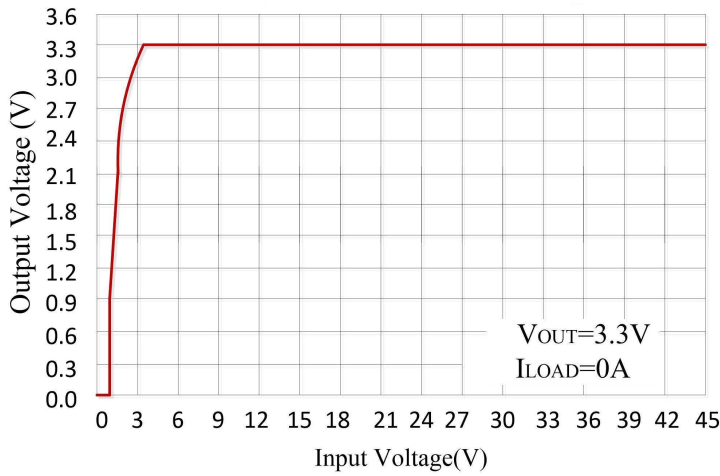

Line transient

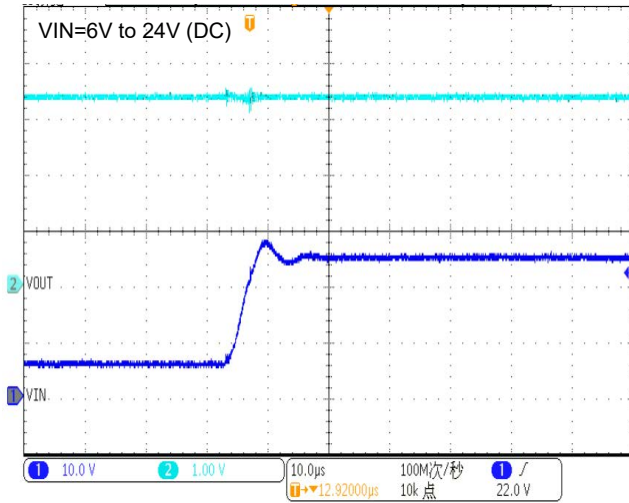

Load transient

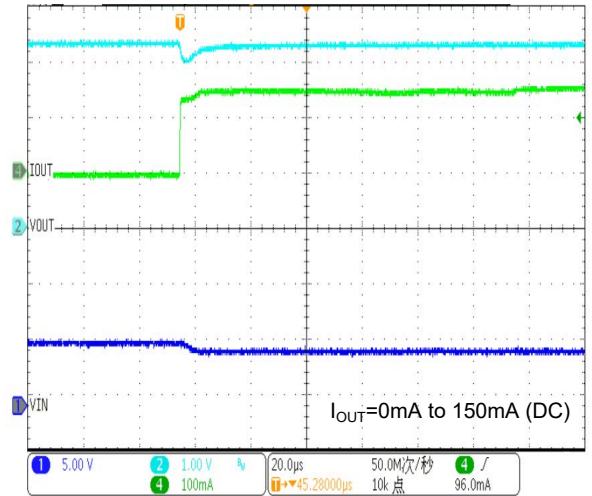

No-load start

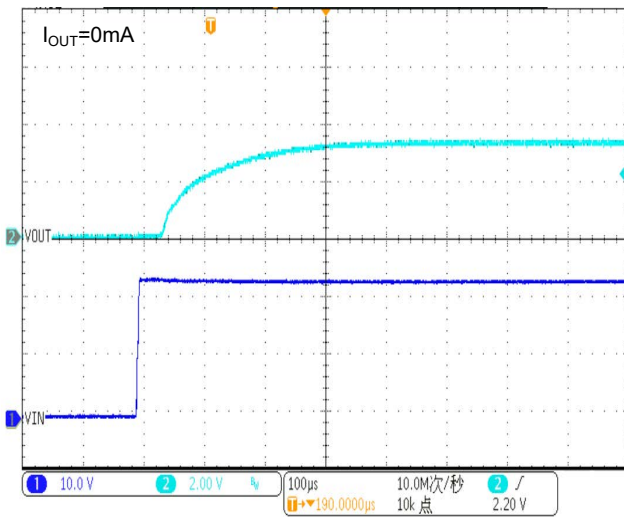

Start with load

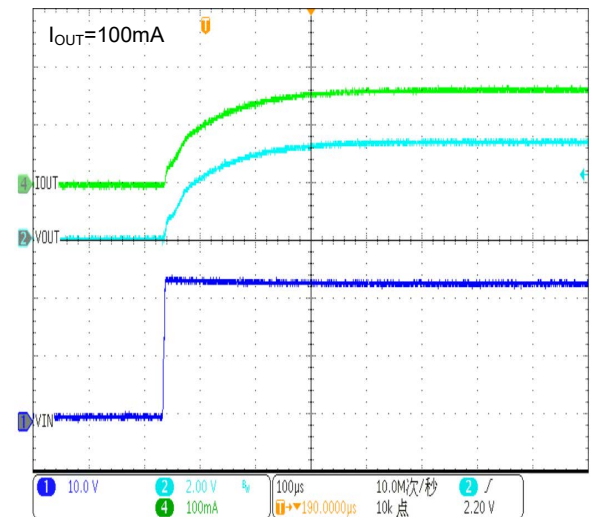

Short-circuit Power-on

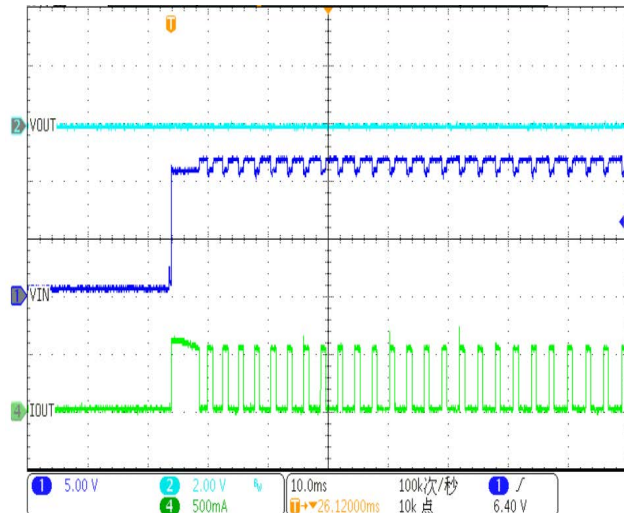

Power-on short

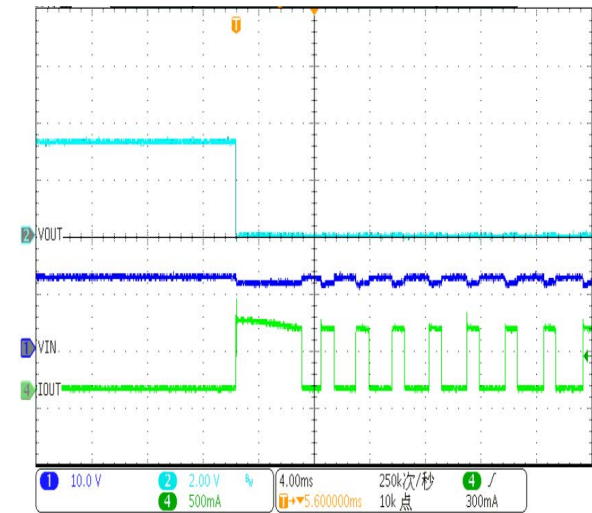



Functional Description

Input Capacitor

A 1 μ F ceramic capacitor is recommended to connect between VIN and GND pins to decouple input power supply glitch and noise. The amount of the capacitance may be increased without limit. This input capacitor must be located as close as possible to the device to assure input stability and less noise. For PCB layout, a wide copper trace is required for both VIN and GND.

Output Capacitor

An output capacitor is required for the stability of the LDO. The recommended minimum output capacitance is 10 μ F, ceramic capacitor is recommended, and temperature characteristics are X7R or X5R. Higher capacitance values help to improve load/line transient response. The output capacitance may be increased to keep low undershoot/overshoot. Place output capacitor as close as possible to VOUT and GND pins.

Current Limit and Short Circuit Protection

When output current at VOUT pin is higher than current limit threshold or the VOUT pin is direct short to GND, the current limit protection will be triggered and clamp the output current at a pre-designed level to prevent over-current and thermal damage.

Thermal Protection

The PJ54A Series has internal thermal sense and protection circuits. When excessive power dissipation happens on the device, such as short circuit at the output pin or very heavy load current with a large voltage drop across the device, the internal thermal protection circuit will be triggered, and it will shut down the power MOSFET to prevent the LDO from damage. As soon as excessive thermal condition is removed and the temperature of the device drops down, the thermal protection circuit will lease the control of the power MOSFET, and the LDO device goes to normal operation.



PJ54A Series Low Dropout Regulators

Package Outline

SOT-23

Dimensions in mm

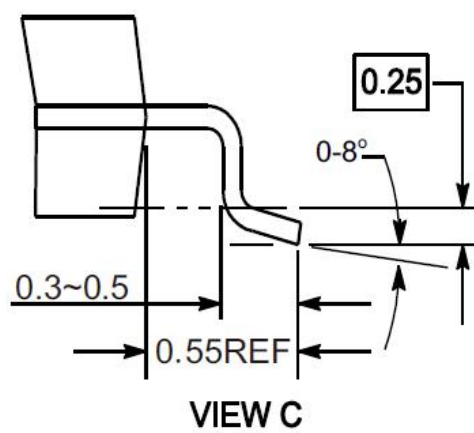
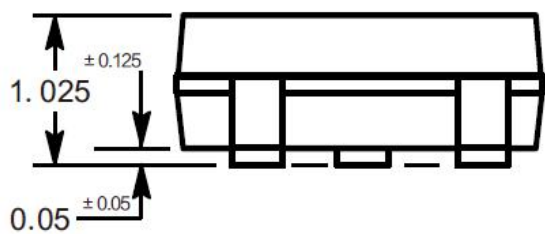
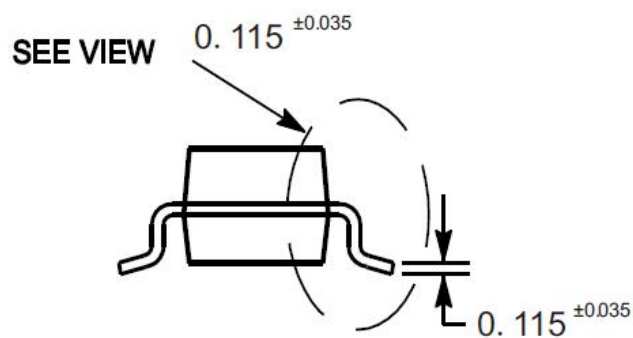
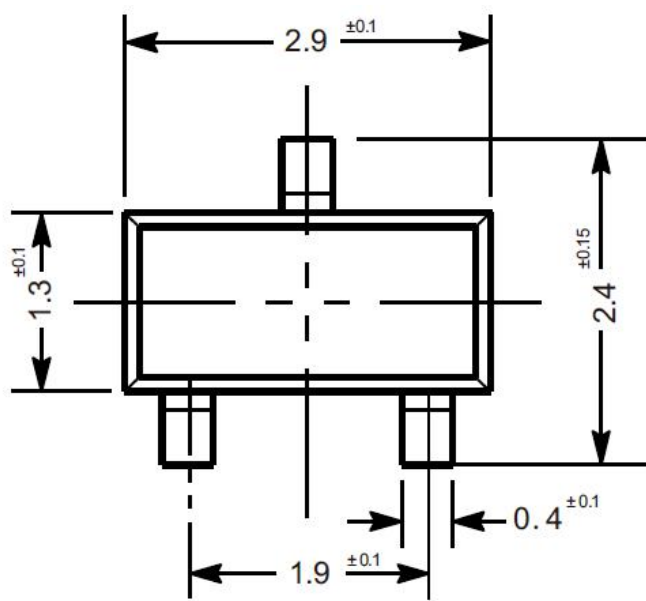



Package Outline

SOT-89

Dimensions in mm

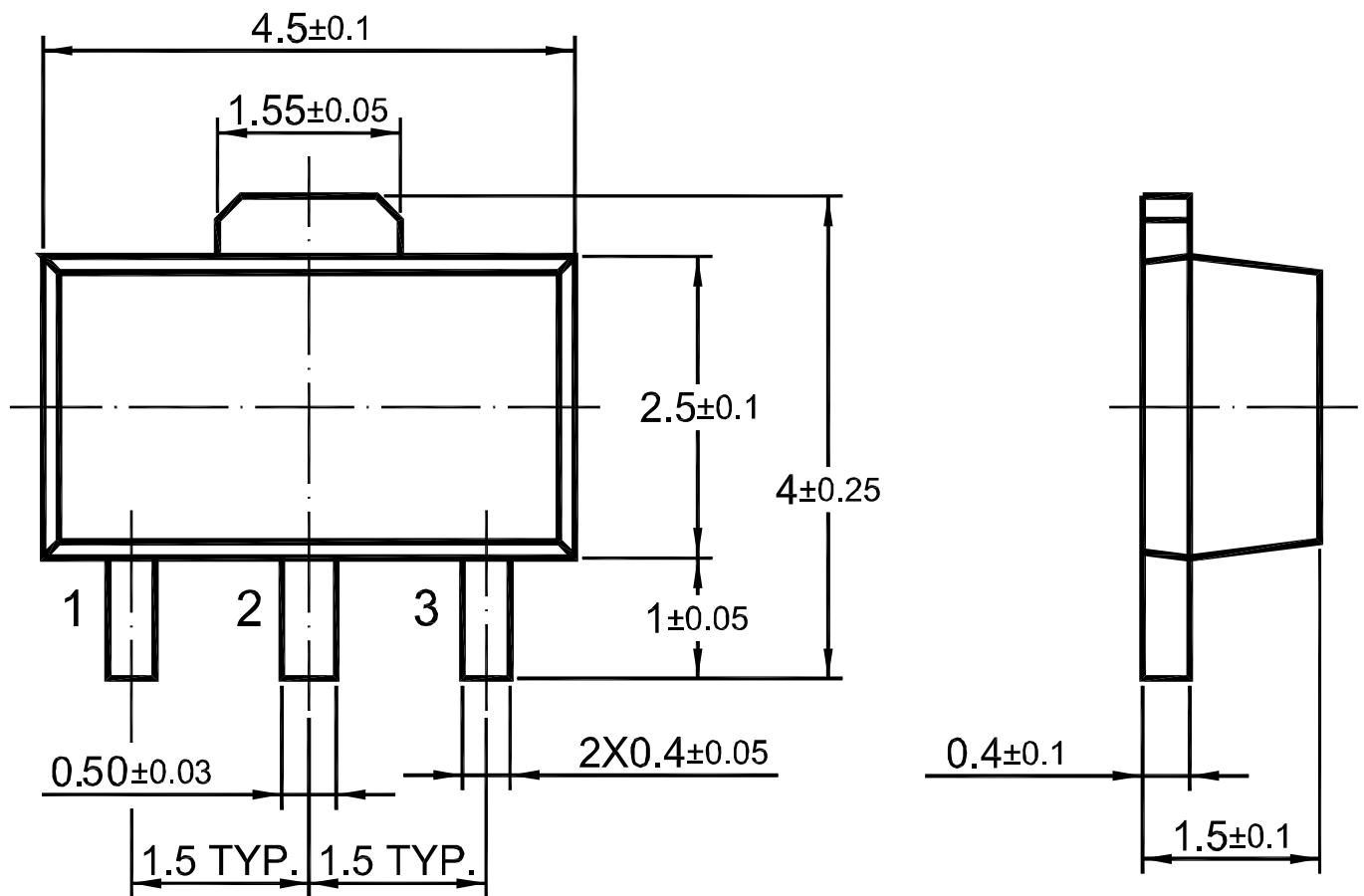



PJ54A Series Low Dropout Regulators

Package Outline

SOT-23-3

Dimensions in mm

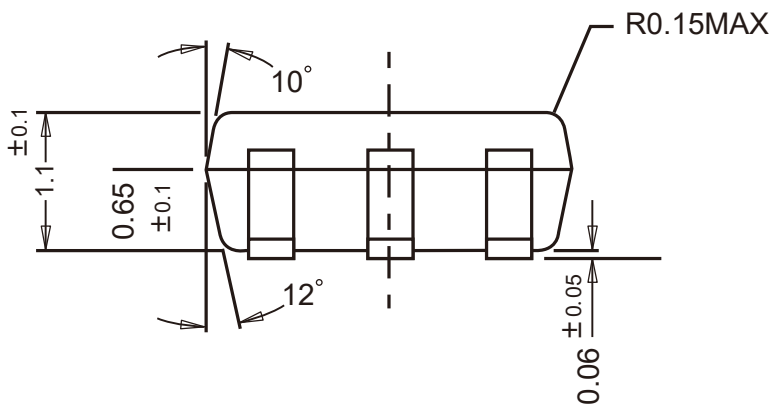
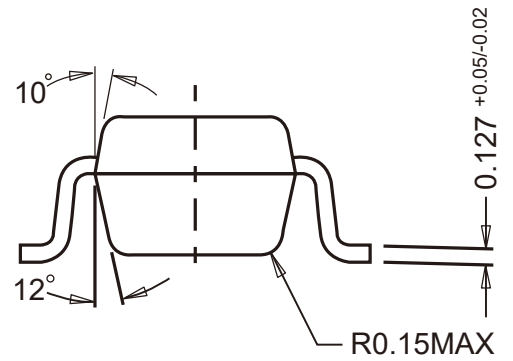
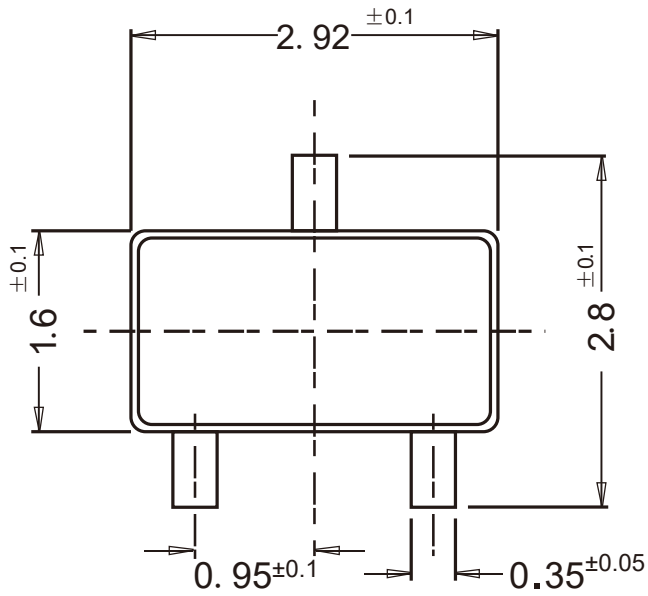

X-ON Electronics

Largest Supplier of Electrical and Electronic Components

Click to view similar products for [LDO Voltage Regulators](#) category:

Click to view products by [Pingjingsemi](#) manufacturer:

Other Similar products are found below :

[AP7363-SP-13](#) [NCV8664CST33T3G](#) [L79M05TL-E](#) [AP7362-HA-7](#) [PT7M8202B12TA5EX](#) [TCR3DF185,LM\(CT](#) [TLF4949EJ](#)
[NCP4687DH15T1G](#) [NCV8703MX30TCG](#) [LP2951CN](#) [NCV4269CPD50R2G](#) [AP7315-25W5-7](#) [NCV47411PAAJR2G](#) [AP2111H-1.2TRG1](#)
[ZLDO1117QK50TC](#) [AZ1117ID-ADJTRG1](#) [NCV4263-2CPD50R2G](#) [NCP114BMX075TCG](#) [MC33269T-3.5G](#) [TLE4471GXT](#) [AP7315-33SA-](#)
[7](#) [NCV4266-2CST33T3G](#) [NCP715SQ15T2G](#) [NCV8623MN-50R2G](#) [NCV563SQ18T1G](#) [NCV8664CDT33RKG](#) [NCV4299CD250R2G](#)
[NCV8702MX25TCG](#) [TLE7270-2E](#) [NCV562SQ25T1G](#) [AP2213D-3.3TRG1](#) [AP2202K-2.6TRE1](#) [NCV8170BMX300TCG](#)
[NCV8152MX300180TCG](#) [NCP700CMT45TBG](#) [AP7315-33W5-7](#) [NCP154MX180300TAG](#) [AP2210K-3.0TRE1](#) [AP2113AMTR-G1](#)
[NJW4104U2-33A-TE1](#) [MP2013AGG-5-P](#) [NCV8775CDT50RKG](#) [NJM2878F3-45-TE1](#) [S-19214B00A-V5T2U7](#) [S-19214B50A-V5T2U7](#) [S-](#)
[19213B50A-V5T2U7](#) [S-19214BC0A-E8T1U7*1](#) [S-19213B00A-V5T2U7](#) [S-19213B33A-V5T2U7](#) [S-19213BC0A-V5T2U7](#)