



Description

The PJ54 Series is a high input voltage, low quiescent current, low-dropout linear regulator able to provide 300mA load current. The LDO features very fast response against line voltage transient and load current transient, and ensures no overshoot voltage during the LDO start up and short circuit recovery.

The device features integrated short-circuit and thermal shutdown protection.

Features

- High Input Voltage Rating: Up to 55V
- Maximum Output Current: 350mA
- Standard Fixed Output Voltage Options: 1.8V, 2.8V, 3V, 3.3V, 5V, 6V
- Low Quiescent Current: 2.1uA
- PSRR=85dB@1KHz
- Low Dropout: 350mV @ 100mA
- Low Output Voltage Accuracy: $\pm 2\%$
- Fast Transient Response
- Thermal Shutdown Protection, Current Limiting Protection
- Available Packages: SOT-23, SOT-23-3, SOT-89, SOT-89-5, SOT-23-5, DFN1x1-4L and DFN2x2C-6L

Applications

- Battery-Powered Equipment
- Smoke Detector and Sensor
- Micro Controller Applications

Typical Application Circuit

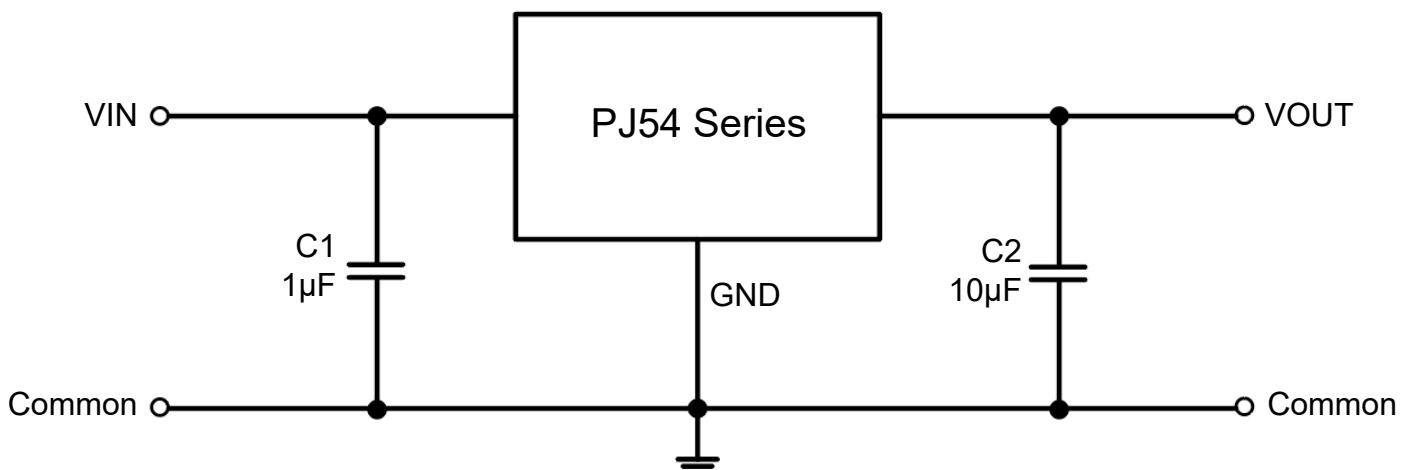

Pin Distribution

SOT-23

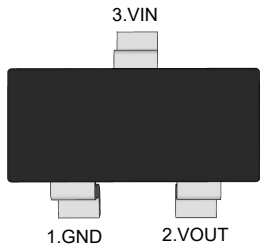

(Top View)

SOT-23-3

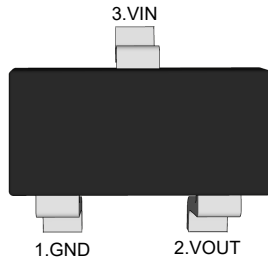

(Top View)

SOT-89

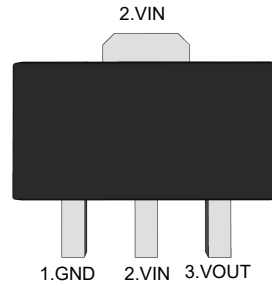

(Top View)

SOT-89-5

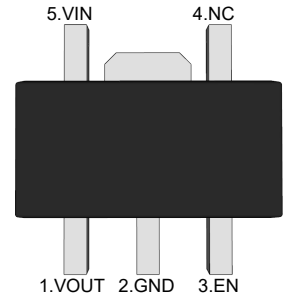

(Top View)

SOT-23-5

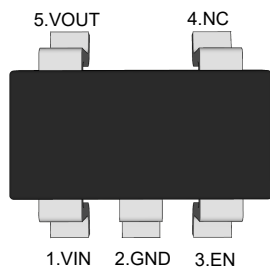

(Top View)

DFN1x1-4L

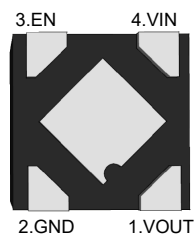

(Bottom View)

DFN2x2C-6L

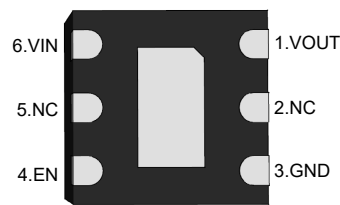

Bottom View

SOT-89-5

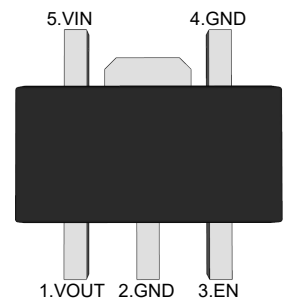

(Top View)

PJ54-A Series

Functional Pin Description

Pin Name	Pin Function
EN	Chip Enable (Active High). Note that this pin is high impedance
NC	NO Connected
GND	Ground
VOUT	Output Voltage
VIN	Power Input Voltage

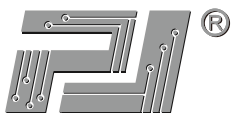

PJ54 Series Low Dropout Regulators

Ordering Information

PJ54 □□□□□

Pin arrangement version number
 □(Blank): Normal pin arrangement version
 -A: A version pin arrangement

Package Type
 SA:SOT-23 SC:SOT-23-3 SQ:SOT-89
 SR:SOT-89-5 SE:SOT-23-5
 DE:DFN1x1-4L DFC:DFN2x2C-6L

Output Voltage
 18 : 1.8V 28 : 2.8V 30 : 3V
 33 : 3.3V 50 : 5V 60 : 6V

Output current tap
 M : 350mA

Orderable Device	Package	Reel (inch)	Package Qty (PCS)	Eco Plan ^{Note1}	MSL Level	Marking Code
PJ54M18SA	SOT-23	7	3000	RoHS & Green	MSL1	 XX:Output Voltage e.g. 18:1.8V
PJ54M28SA						
PJ54M30SA						
PJ54M33SA						
PJ54M50SA						
PJ54M60SA						
PJ54M18SQ	SOT-89	7/13	1000/3000	RoHS & Green	MSL1	 XX:Output Voltage e.g. 18:1.8V
PJ54M28SQ						
PJ54M30SQ						
PJ54M33SQ						
PJ54M50SQ						
PJ54M60SQ						



PJ54 Series Low Dropout Regulators

Ordering Information Continue

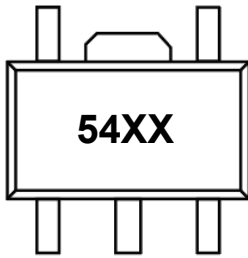
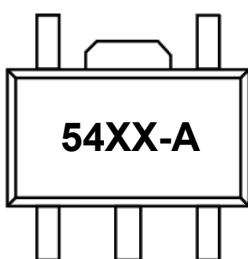
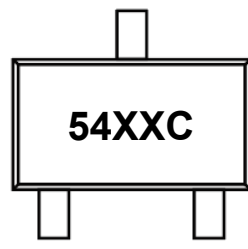
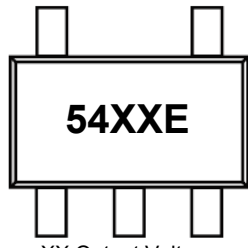
Orderable Device	Package	Reel (inch)	Package Qty (PCS)	Eco Plan ^{Note1}	MSL Level	Marking Code
PJ54M18SR	SOT-89-5	7/13	1000/3000	RoHS & Green	MSL1	 <p>54XX</p> <p>XX:Output Voltage e.g. 18:1.8V</p>
PJ54M28SR						
PJ54M30SR						
PJ54M33SR						
PJ54M50SR						
PJ54M60SR						
PJ54M18SR-A	SOT-89-5	7/13	1000/3000	RoHS & Green	MSL1	 <p>54XX-A</p> <p>XX:Output Voltage e.g. 18:1.8V</p>
PJ54M28SR-A						
PJ54M30SR-A						
PJ54M33SR-A						
PJ54M50SR-A						
PJ54M60SR-A						
PJ54M18SC	SOT-23-3	7	3000	RoHS & Green	MSL3	 <p>54XXC</p> <p>XX:Output Voltage e.g. 18:1.8V</p>
PJ54M28SC						
PJ54M30SC						
PJ54M33SC						
PJ54M50SC						
PJ54M60SC						
PJ54M18SE	SOT-23-5	7	3000	RoHS & Green	MSL3	 <p>54XXE</p> <p>XX:Output Voltage e.g. 18:1.8V</p>
PJ54M28SE						
PJ54M30SE						
PJ54M33SE						
PJ54M50SE						
PJ54M60SE						

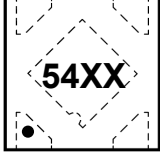

Ordering Information Continue

Orderable Device	Package	Reel (inch)	Package Qty (PCS)	Eco Plan ^{Note1}	MSL Level	Marking Code
PJ54M18DE	DFN1x1-4L	7	10000	RoHS & Green	MSL1	 XX:Output Voltage e.g. 18:1.8V
PJ54M28DE						
PJ54M30DE						
PJ54M33DE						
PJ54M50DE						
PJ54M60DE						
PJ54M18DFC	DFN2x2C-6L	7	3000	RoHS & Green	MSL1	 XX:Output Voltage e.g. 18:1.8V
PJ54M28DFC						
PJ54M30DFC						
PJ54M33DFC						
PJ54M50DFC						
PJ54M60DFC						

Note1:

RoHS: PJ defines "RoHS" to mean semiconductor products that are compliant with the current EU RoHS requirements for all 10 RoHS substances, including the requirement that RoHS substance do not exceed 0.1% by weight in homogeneous materials.

Green: PJ defines "Green" to mean Halogen-Free and Antimony-Free.

Function Block Diagram

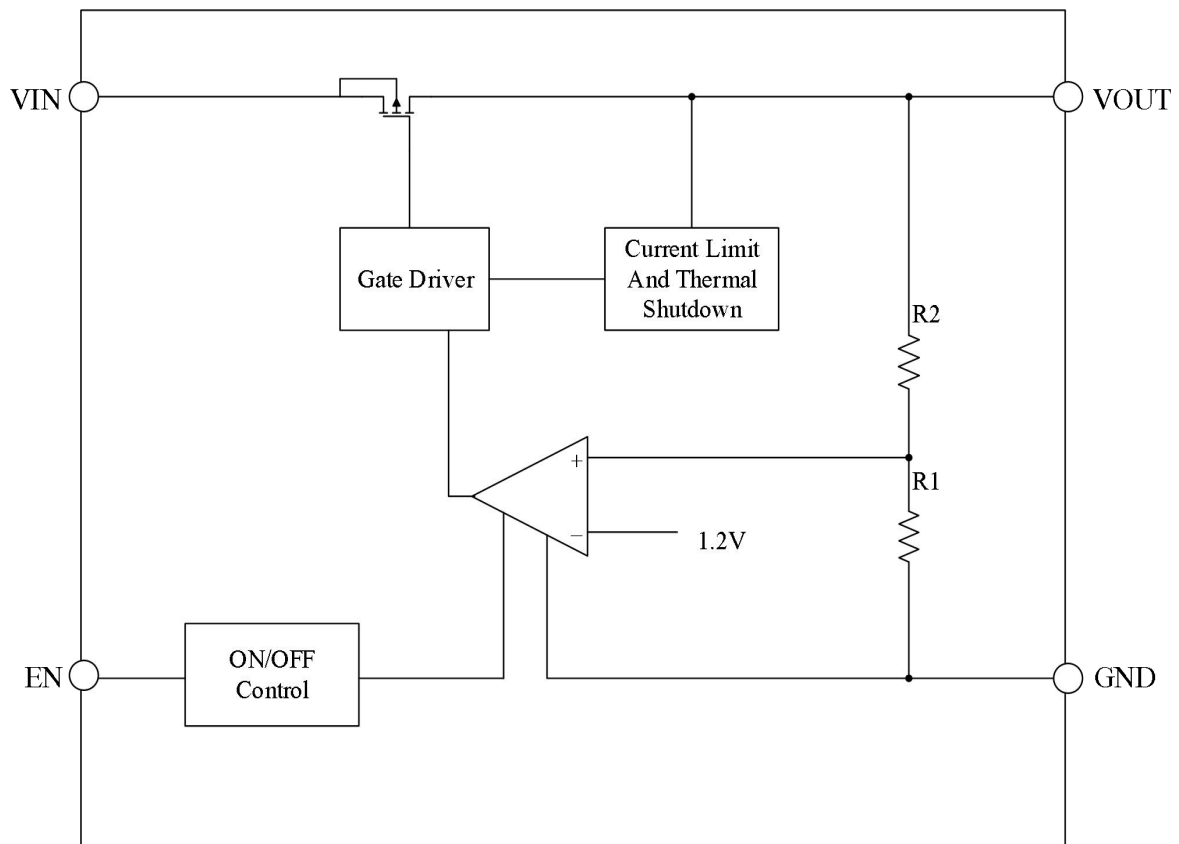



PJ54 Series Low Dropout Regulators

Absolute Maximum Ratings ^{Note2}

Ratings at 25°C ambient temperature unless otherwise specified.

Parameter		Value	Unit
VIN to GND Voltage		-0.3 ~ +55	V
VOUT to GND Voltage		-0.3 ~ +6	V
VOUT to VIN Voltage		-55 ~ +0.3	V
EN to GND Voltage		-0.3 ~ +55	V
Output Current		Internally limited	--
Power Dissipation	SOT-23	320	mW
	SOT-23-3	500	mW
	SOT-89	920	mW
	SOT-89-5	920	mW
	SOT-23-5	500	mW
	DFN1x1-4L	500	mW
	DFN2x2C-6L	1700	mW
Thermal Resistance, Junction-to-Ambient	SOT-23	380	°C/W
	SOT-23-3	250	°C/W
	SOT-89	135	°C/W
	SOT-89-5	135	°C/W
	SOT-23-5	250	°C/W
	DFN1x1-4L	250	°C/W
	DFN2x2C-6L	73	°C/W
Operating Ambient Temperature		-40 ~ +85	°C
Junction temperature		150	°C
Storage temperature range		-40 ~ +150	°C

Note2: Exceed these limits to damage to the device, exposure to absolute maximum rating conditions may affect the reliability of the chip.

Recommended Operating Conditions

Parameter	Value	Unit
Supply Voltage	3~45	V
Maximum Output Current	350	mA
Operating Ambient Temperature	-40 ~ +85	°C



Electrical Characteristics

($V_{IN}=V_{OUT}+1$, $C_{IN}=1\mu F$, $C_{OUT}=10\mu F$, $T_A=25^\circ C$, unless otherwise noted.)

Parameter	Symbol	Test Conditions	Min.	Typ.	Max.	Unit
Input Voltage	V_{IN}		3	--	45	V
Output Voltage Accuracy	ΔV_{OUT}	$V_{IN}=12V$, $I_{OUT}=10mA$	-2	--	+2	%
Quiescent Current	I_Q	$V_{IN}=12V$, $I_{OUT}=0mA$	--	2.1	--	μA
Maximum Output Current	I_{OUT_Max}		300	350	--	mA
Dropout Voltage ^{Note3}	V_{DROP}	$V_{IN}=V_{OUTNOM}-0.1V$, $I_{OUT}=10mA$	--	35	--	mV
		$V_{IN}=V_{OUTNOM}-0.1V$, $I_{OUT}=100mA$	--	350	--	
Line Regulation	ΔV_{LINE}	$V_{OUTNOM}+0.5V \leq V_{IN} \leq 40V$ $I_{OUT}=1mA$	--	0.01	--	%/V
Load Regulation	ΔV_{LOAD}	$V_{IN}=12V$, $1mA < I_{OUT} < 100mA$	--	0.02	--	%/mA
Current Limit	I_{LIM}		--	500	--	mA
EN Input Threshold	Logic Low	V_{IL}	--	--	0.4	V
	Logic High	V_{IH}	1	--	--	V
Output Noise Voltage	V_N	10Hz~100KHz, $C_{OUT}=1\mu F$ $V_{OUT}=3V$	--	110	--	μV_{RMS}
Power Supply Rejection Ratio	PSRR	$V_{IN}=12V$, $I_{OUT}=10mA$ $f=1KHz$, $V_{OUT}=3.3V$	--	85	--	dB
Thermal Shutdown Temperature	T_{SHDN}	Shutdown, Temp increasing	--	150	--	$^\circ C$
Thermal Reset Temperature	T_{SHDN}	Reset, Temp decreasing	--	140	--	$^\circ C$

Note3: The dropout voltage difference is the voltage difference between the input and output, where the output voltage is 2% lower than its nominal value.



PJ54 Series Low Dropout Regulators

Typical Characteristic Curves

Test Condition: $T_A=25^{\circ}\text{C}$, $I_{\text{out}}=1\text{mA}$, $C_{\text{OUT}}=10\mu\text{F}$, unless otherwise noted

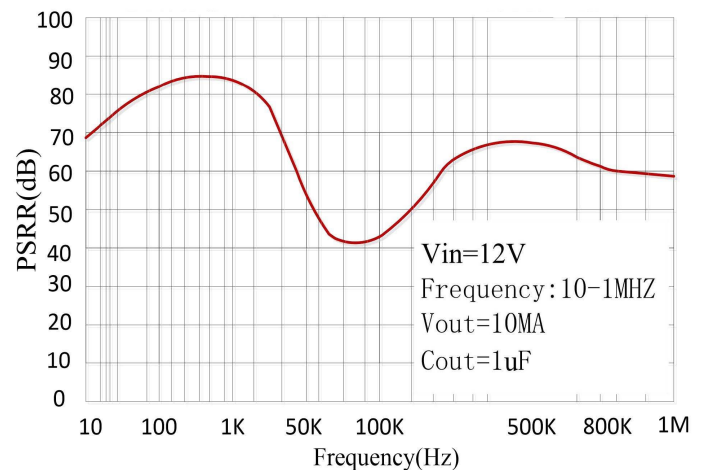
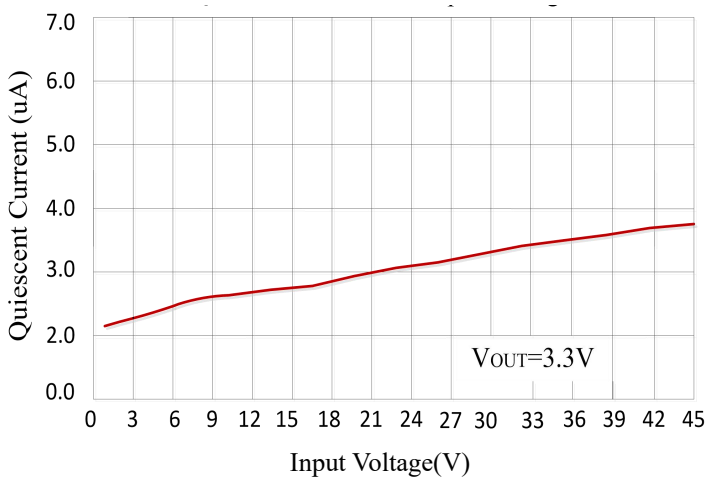
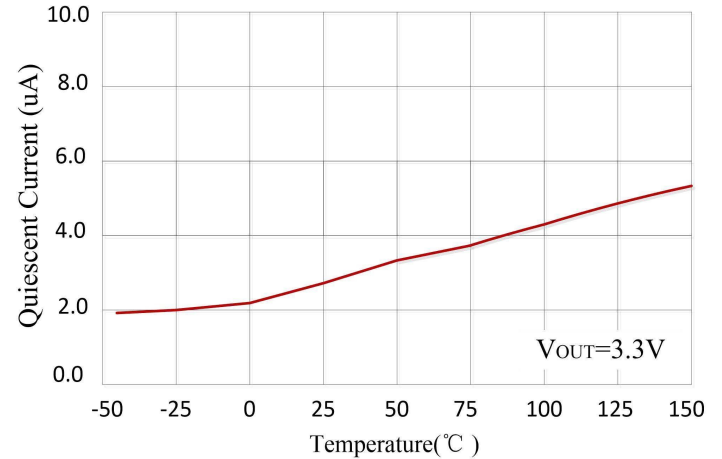
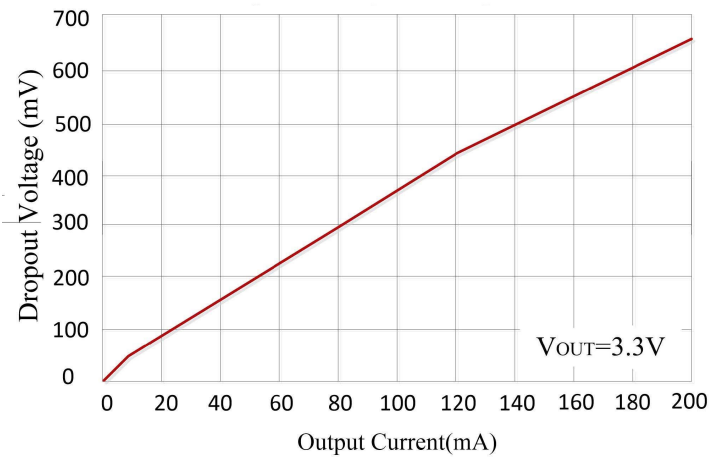
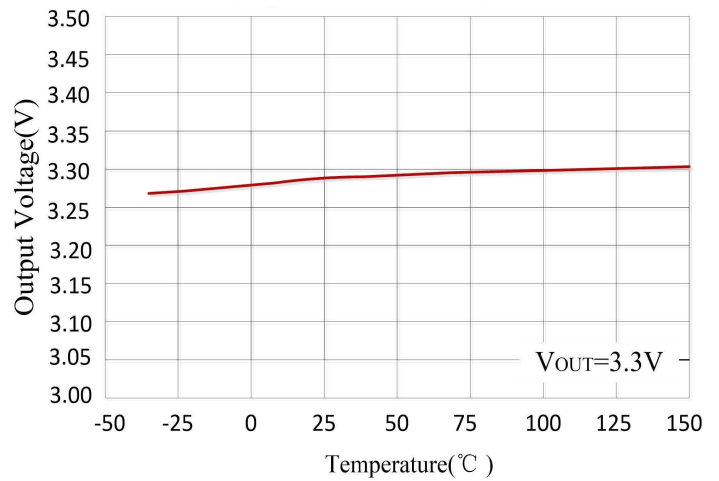
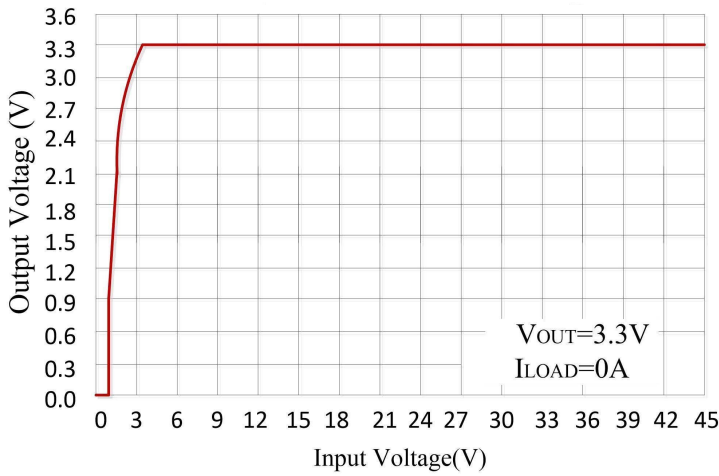

Line transient

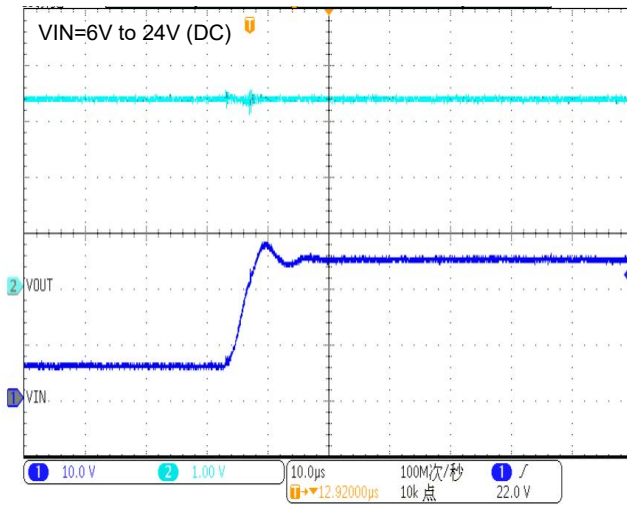

Load transient

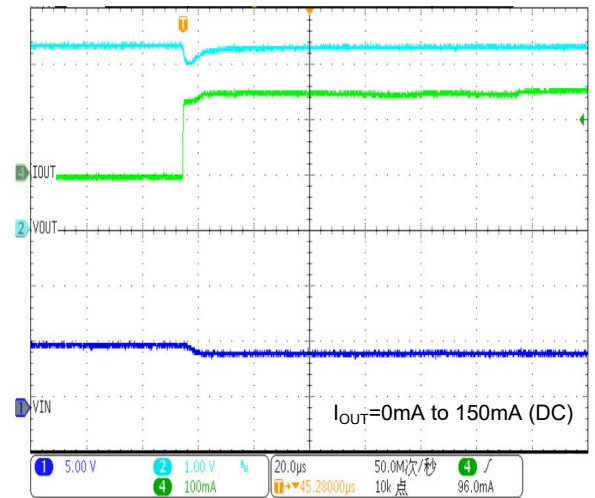

No-load start

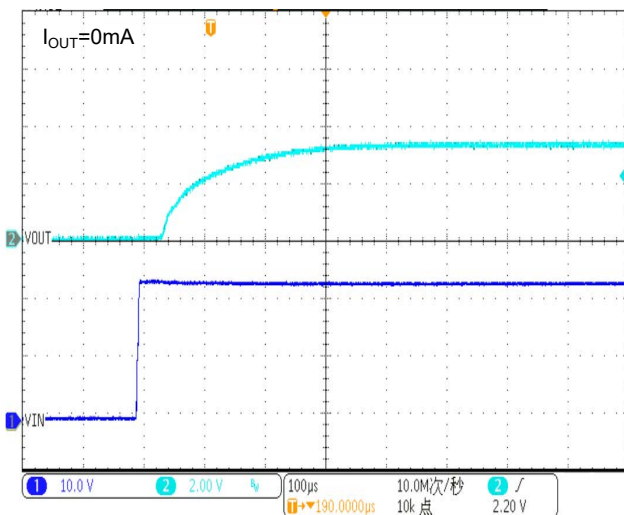

Start with load

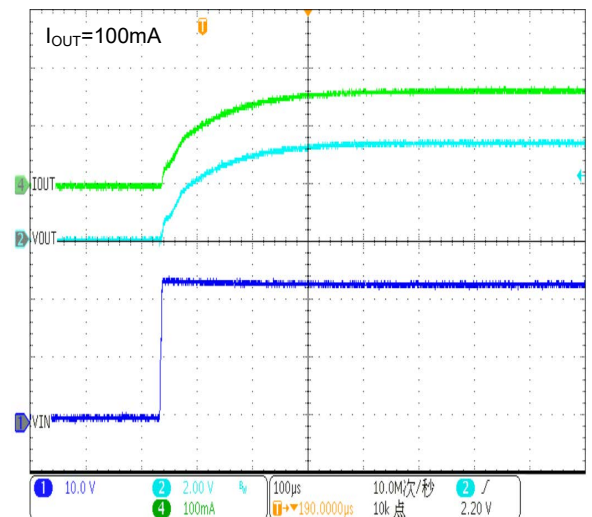

Short-circuit Power-on

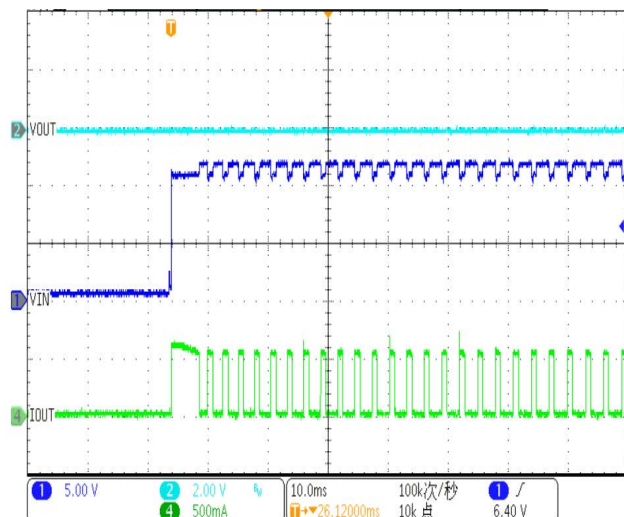

Power-on short

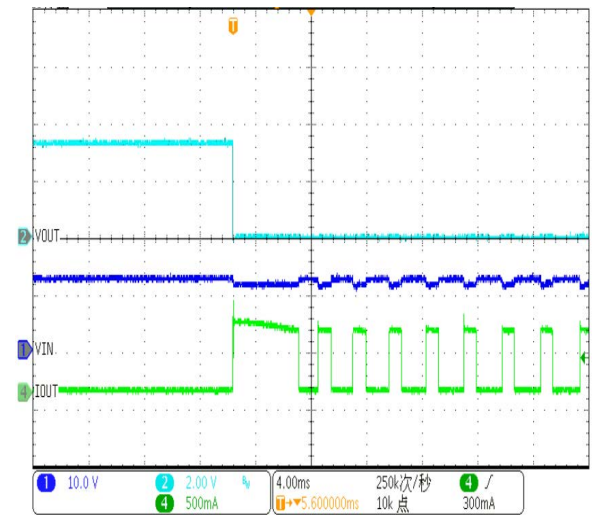



Functional Description

Input Capacitor

A 1 μ F ceramic capacitor is recommended to connect between VIN and GND pins to decouple input power supply glitch and noise. The amount of the capacitance may be increased without limit. This input capacitor must be located as close as possible to the device to assure input stability and less noise. For PCB layout, a wide copper trace is required for both VIN and GND.

Output Capacitor

An output capacitor is required for the stability of the LDO. The recommended minimum output capacitance is 10 μ F, ceramic capacitor is recommended, and temperature characteristics are X7R or X5R. Higher capacitance values help to improve load/line transient response. The output capacitance may be increased to keep low undershoot/overshoot. Place output capacitor as close as possible to VOUT and GND pins.

EN Pin Operation

The PJ54 Series is turned on by setting the EN pin to "H". Since the EN pin is neither pulled down nor pulled up internally, do not set it in floating status. When the EN pin is not used, connect the EN pin with VIN to keep the LDO in operating mode.

Current Limit and Short Circuit Protection

When output current at VOUT pin is higher than current limit threshold or the VOUT pin is direct short to GND, the current limit protection will be triggered and clamp the output current at a pre-designed level to prevent over-current and thermal damage.

Thermal Protection

The PJ54 Series has internal thermal sense and protection circuits. When excessive power dissipation happens on the device, such as short circuit at the output pin or very heavy load current with a large voltage drop across the device, the internal thermal protection circuit will be triggered, and it will shut down the power MOSFET to prevent the LDO from damage. As soon as excessive thermal condition is removed and the temperature of the device drops down, the thermal protection circuit will lease the control of the power MOSFET, and the LDO device goes to normal operation.

Package Outline

SOT-23

Dimensions in mm

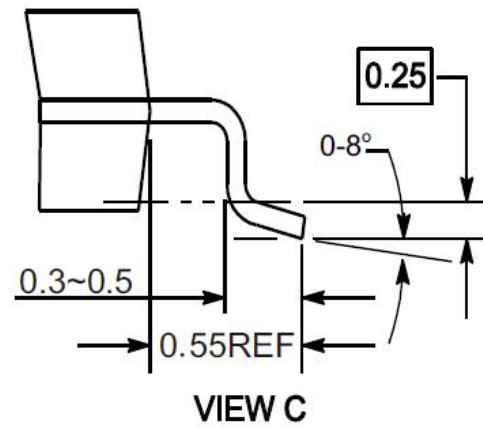
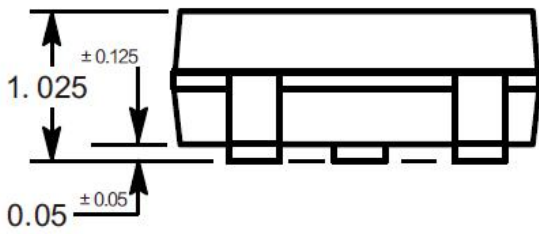
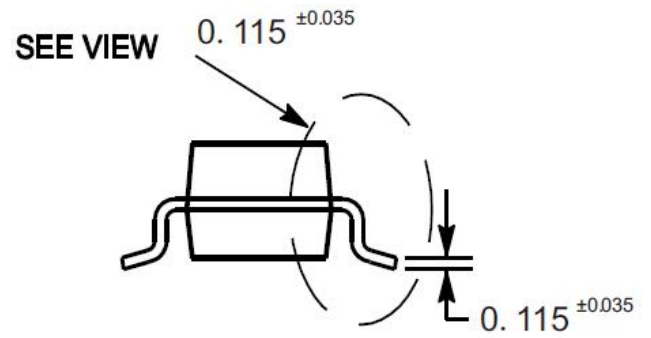
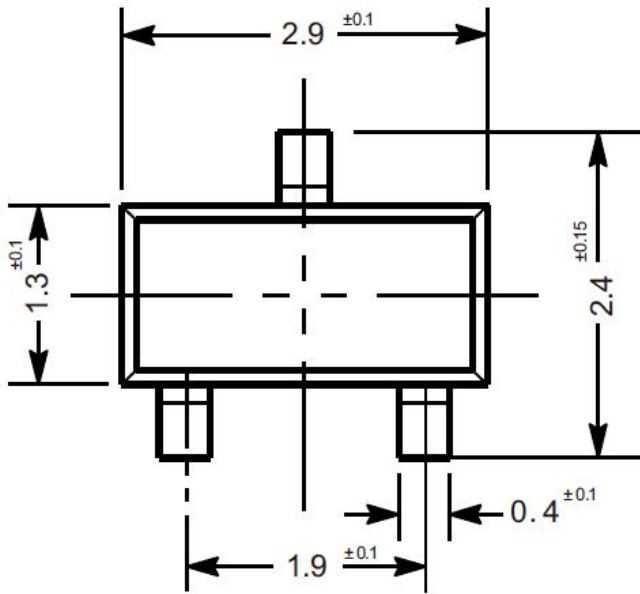



PJ54 Series Low Dropout Regulators

Package Outline

SOT-23-3

Dimensions in mm

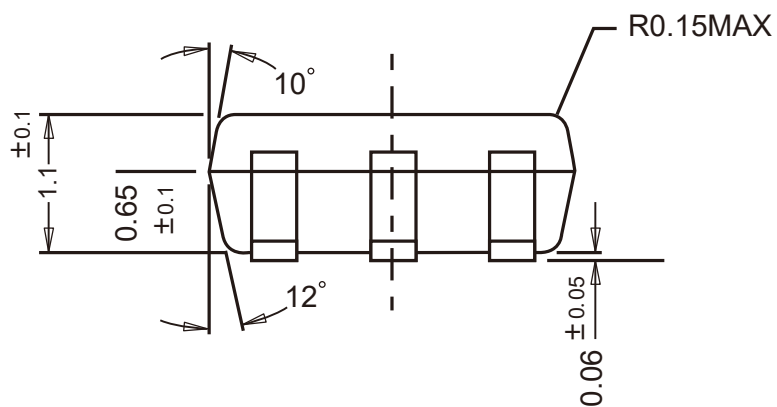
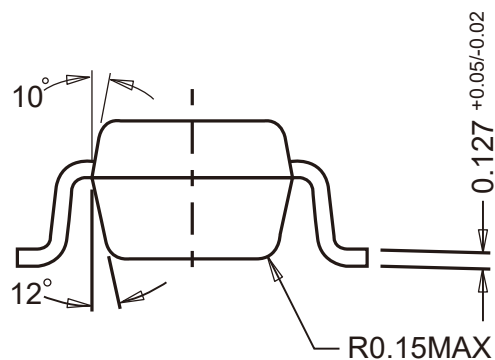
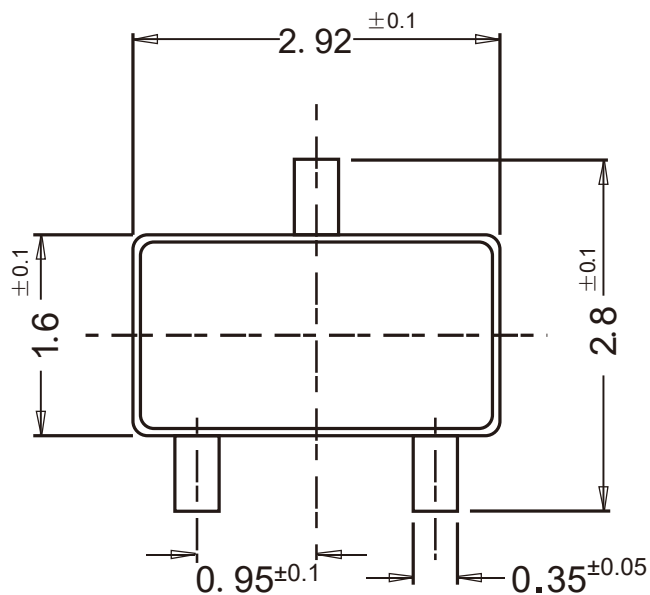

Package Outline

SOT-89

Dimensions in mm

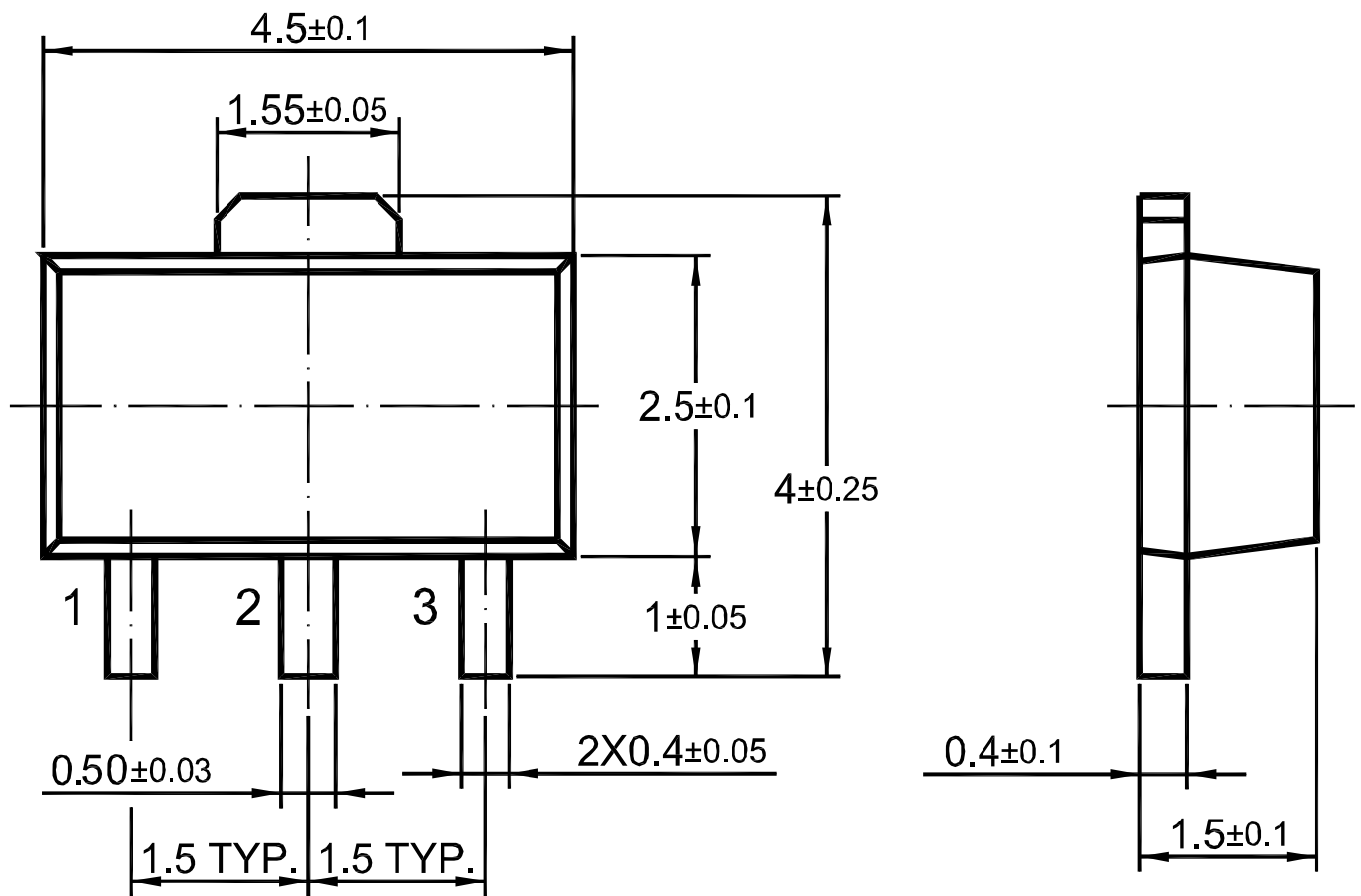



Package Outline

SOT-89-5

Dimensions in mm

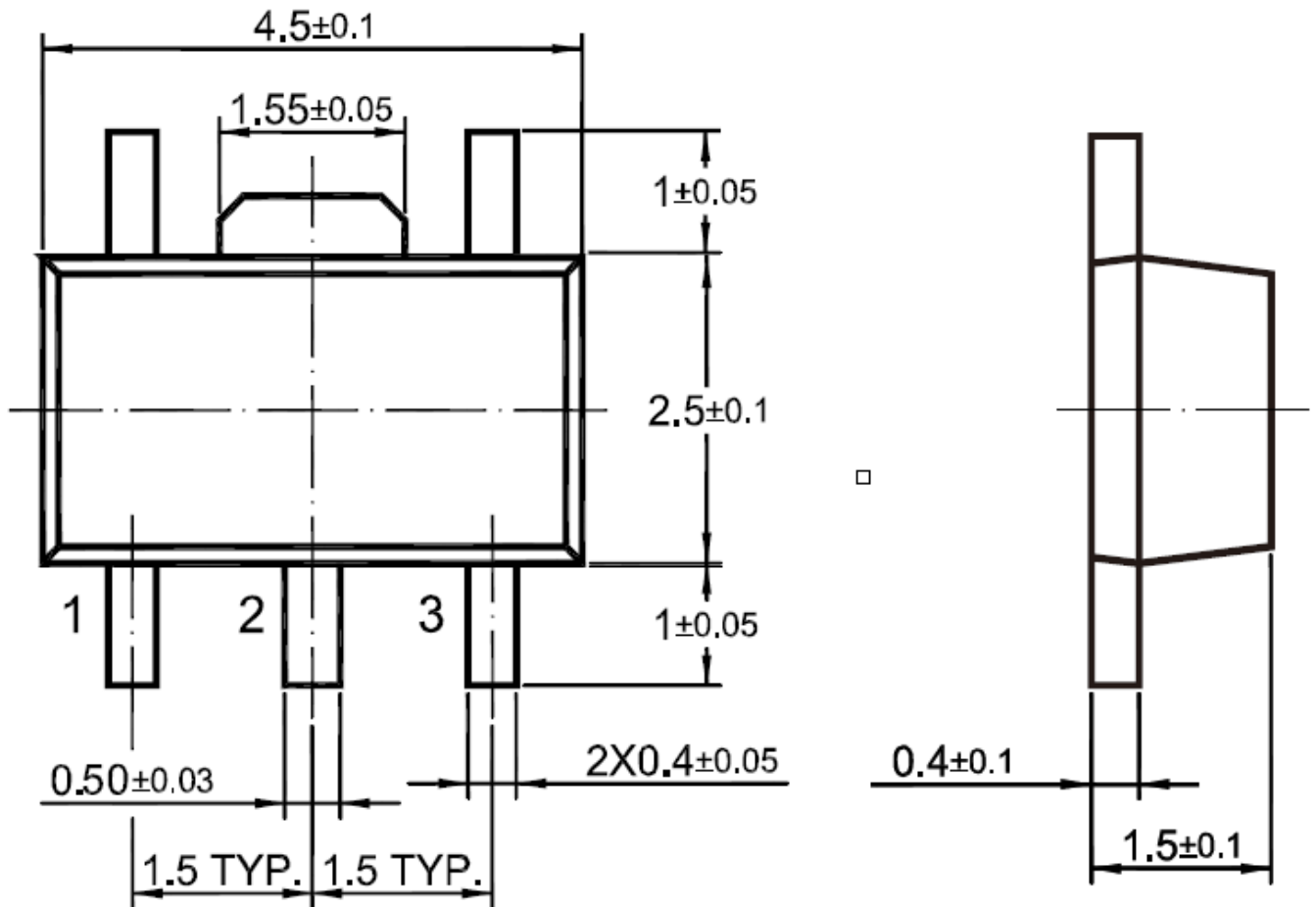



PJ54 Series Low Dropout Regulators

Package Outline

SOT-23-5

Dimensions in mm

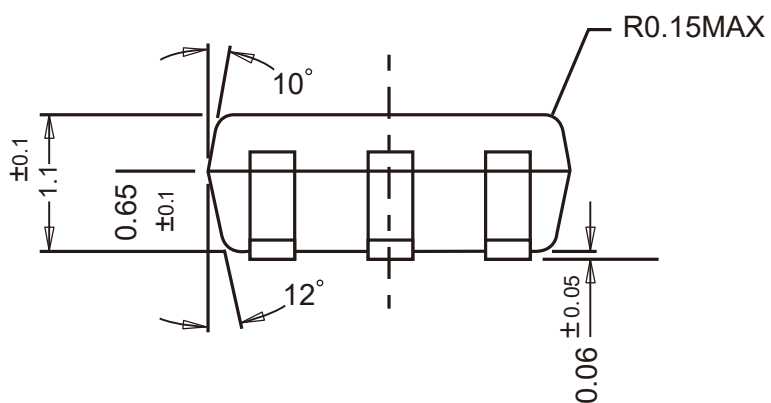
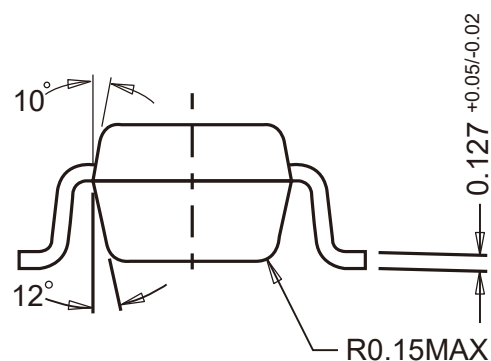
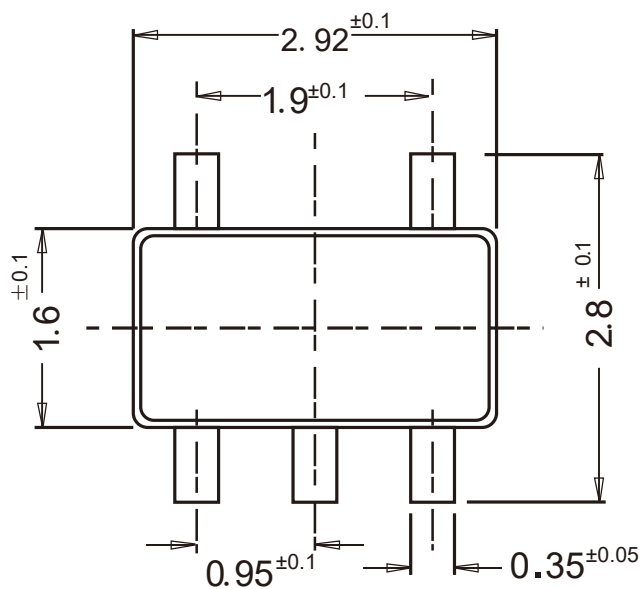



Package Outline

DFN1x1-4L

Dimensions in mm

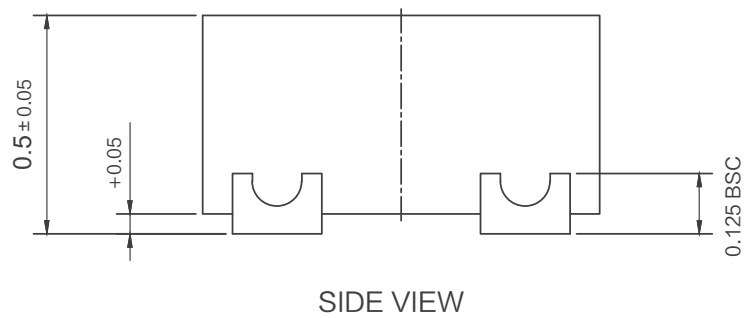
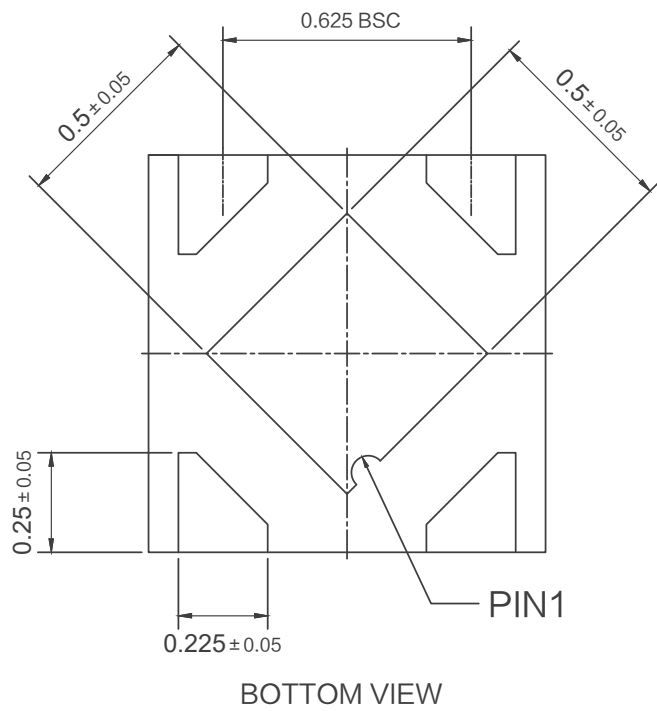
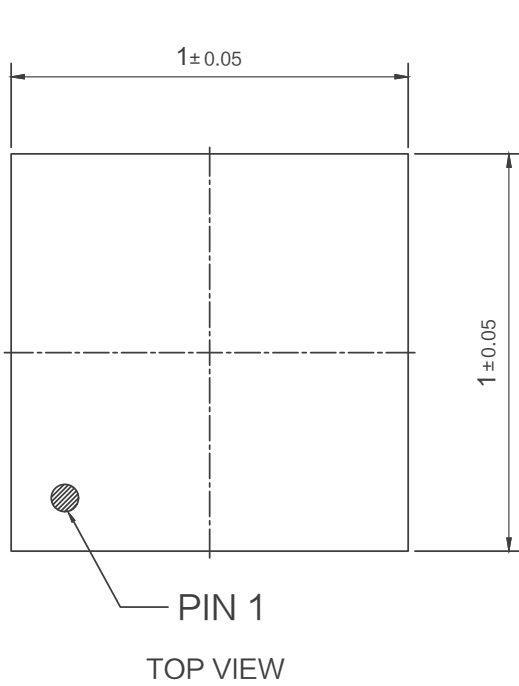

Package Outline

DFN2x2C-6L

Dimensions in mm

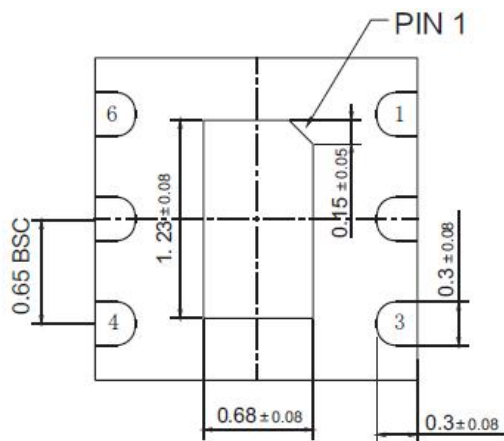

BOTTOM VIEW

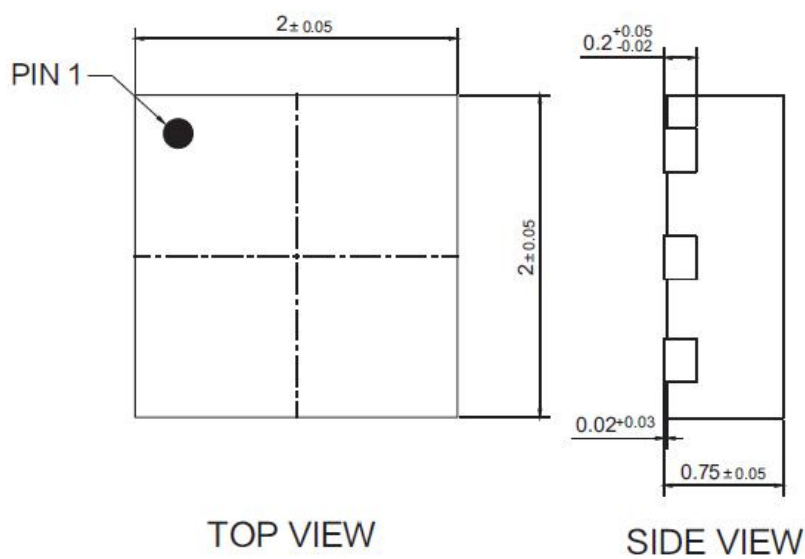

TOP VIEW

SIDE VIEW

Conditions of Soldering and Storage

◆ Recommended condition of reflow soldering

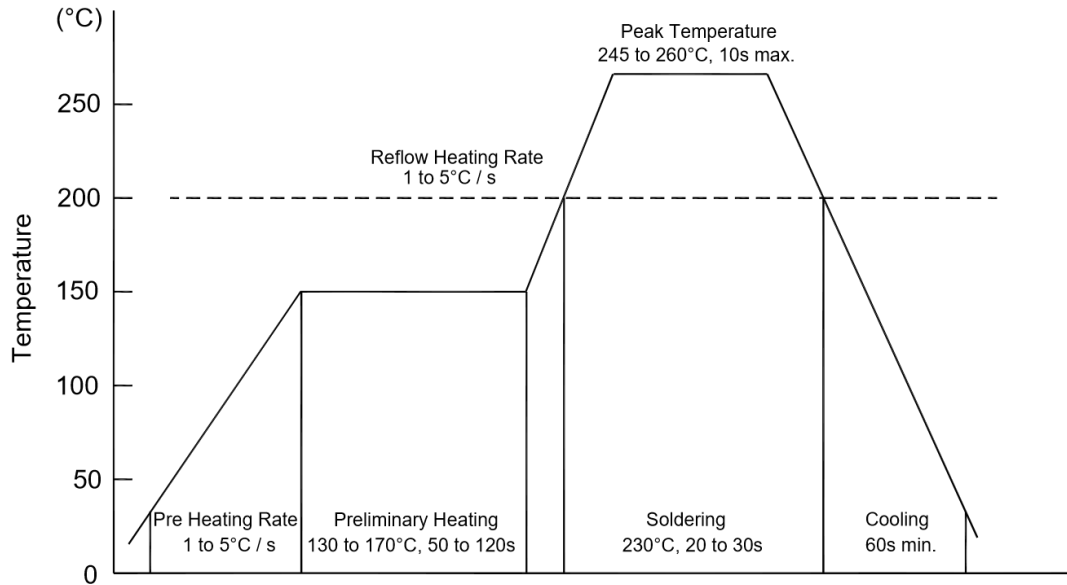

Recommended peak temperature is over 245°C. If peak temperature is below 245°C, you may adjust the following parameters:

- Time length of peak temperature (longer)
- Time length of soldering (longer)
- Thickness of solder paste (thicker)

◆ Conditions of hand soldering

- Temperature: 300°C
- Time: 3s max.
- Times: one time

◆ Storage conditions

- **Temperature**
5 to 40°C
- **Humidity**
30 to 80% RH
- **Recommended period**
One year after manufacturing

Package Specifications (SOT-23/SOT-23-3/SOT-23-5/DFN2x2C-6L)

- The method of packaging

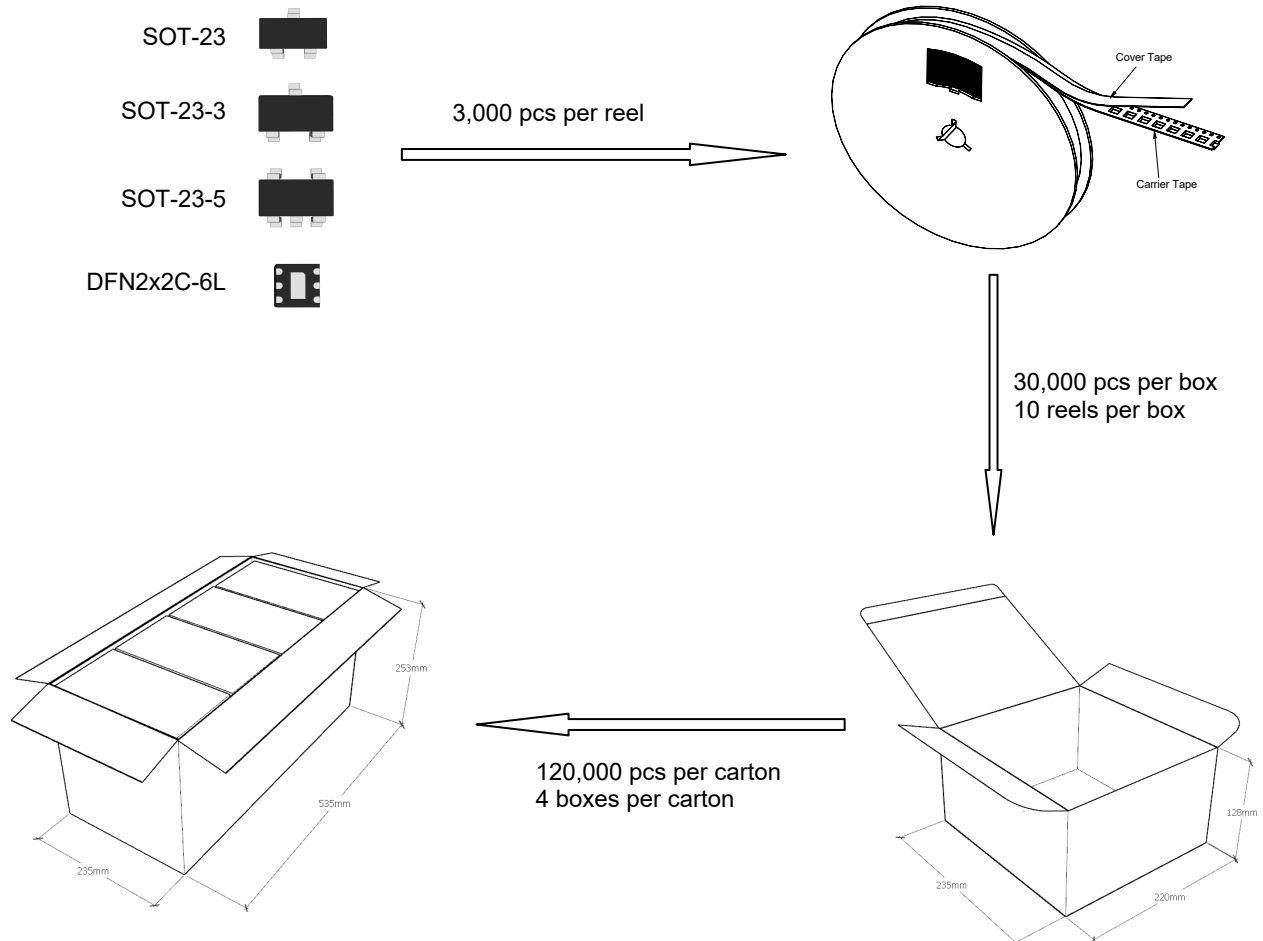

◆ reel data

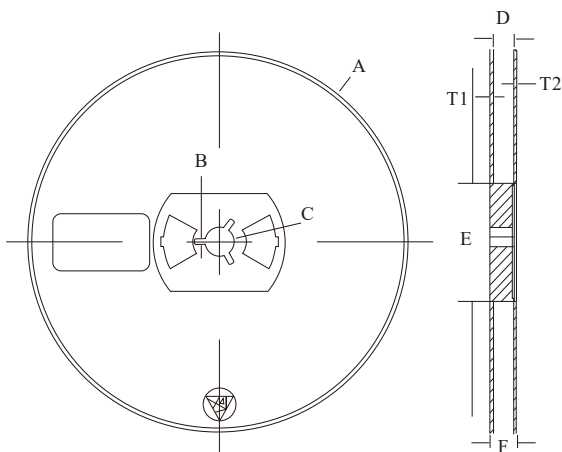

Reel (7")

Symbol	Value (unit: mm)
A	Ø 177.8±1
B	2.7±0.2
C	Ø 13.5±0.2
E	Ø 54.5±0.2
F	12.3±0.3
D	9.6+2/-0.3
T1	1.0±0.2
T2	1.2±0.2

Package Specifications (DFN1x1-4L)

- The method of packaging

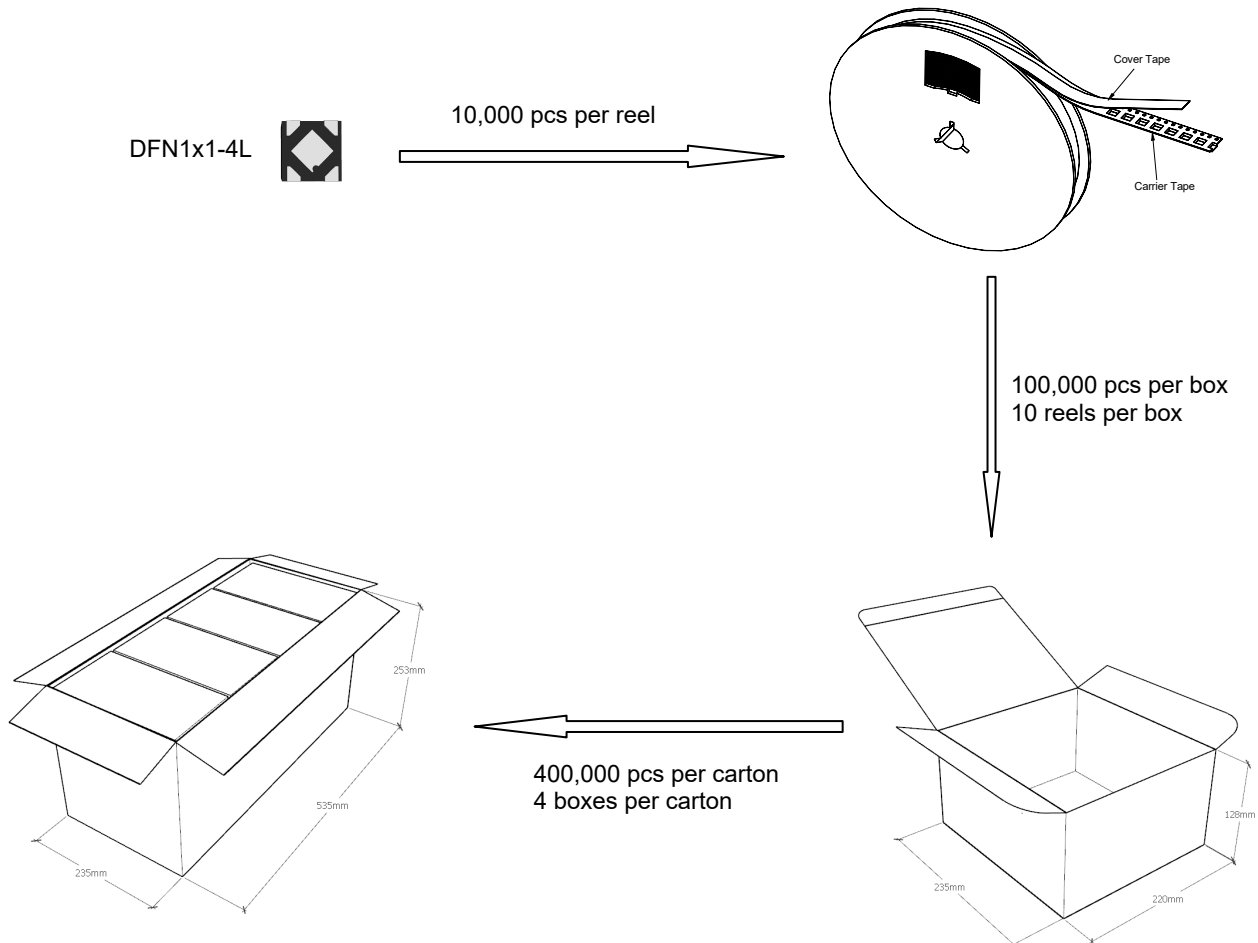

◆ reel data

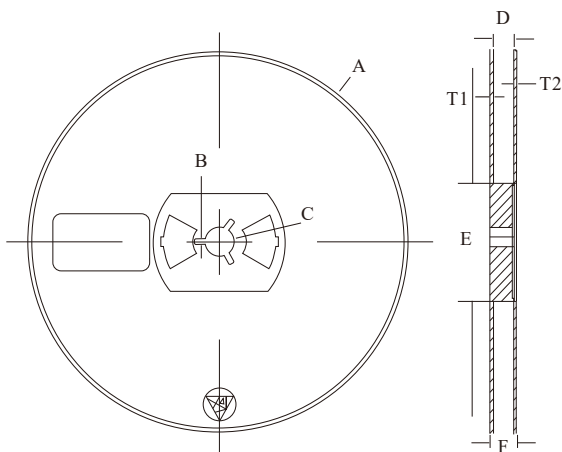

Symbol	Value (unit: mm)
A	$\text{Ø } 177.8 \pm 1$
B	2.7 ± 0.2
C	$\text{Ø } 13.5 \pm 0.2$
E	$\text{Ø } 54.5 \pm 0.2$
F	12.3 ± 0.3
D	$9.6 +2 / -0.3$
T1	1.0 ± 0.2
T2	1.2 ± 0.2

Package Specifications (SOT-89/SOT-89-5)

- The method of packaging (1,000PCS/Reel&7inches)

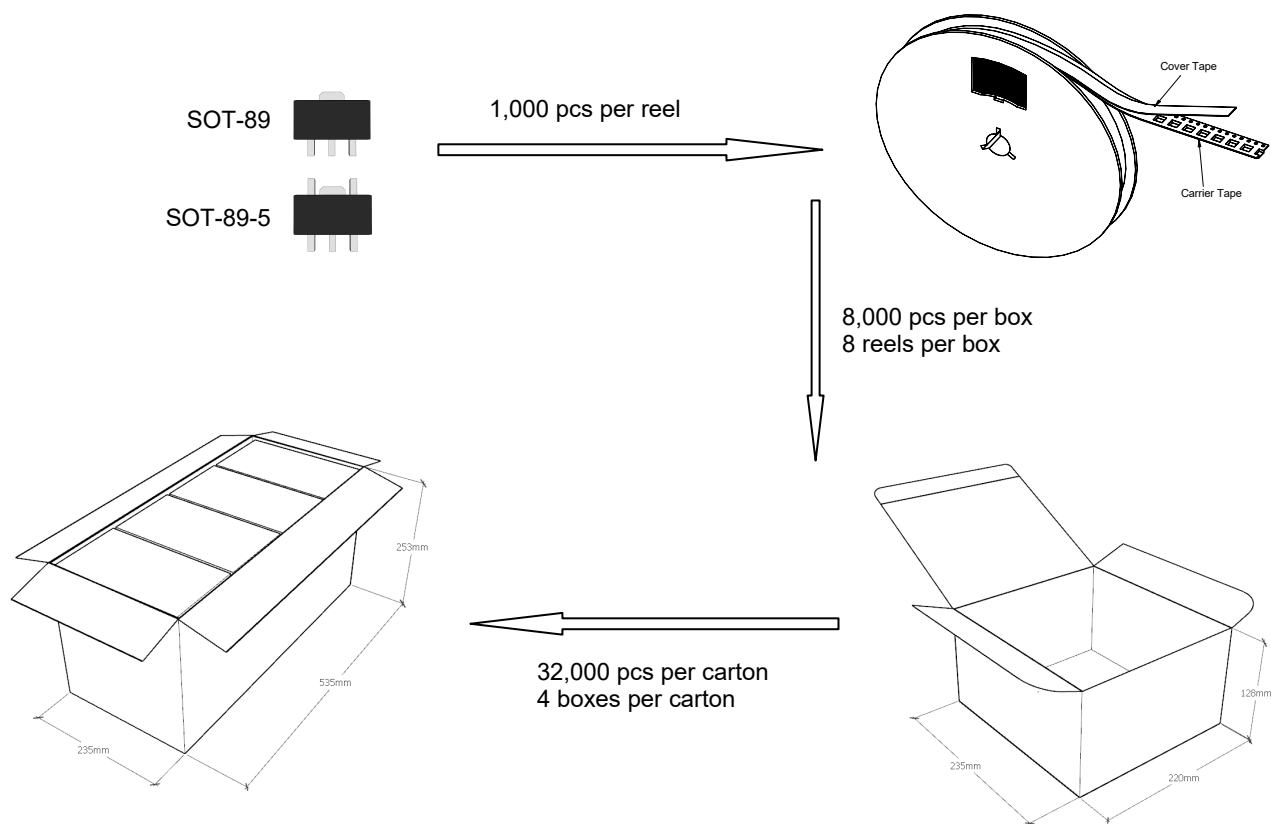

◆ reel data

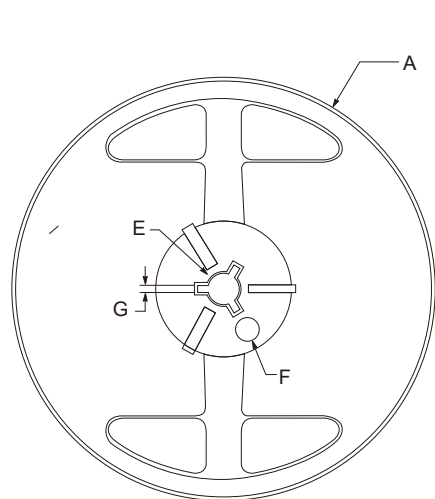

Reel (7")

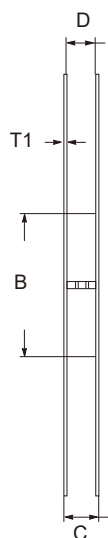

symbol	Value(unit:mm)
A	$\Phi 179 \pm 1$
B	60.5 ± 0.2
C	15.3 ± 0.3
D	12.5~13.7
E	$\Phi 13.5 \pm 0.2$
F	$\Phi 10.0 \pm 0.2$
G	2.7 ± 0.2
T1	1.0 ± 0.2

Package Specifications (SOT-89/SOT-89-5)

- The method of packaging (3,000PCS/Reel&13inches)

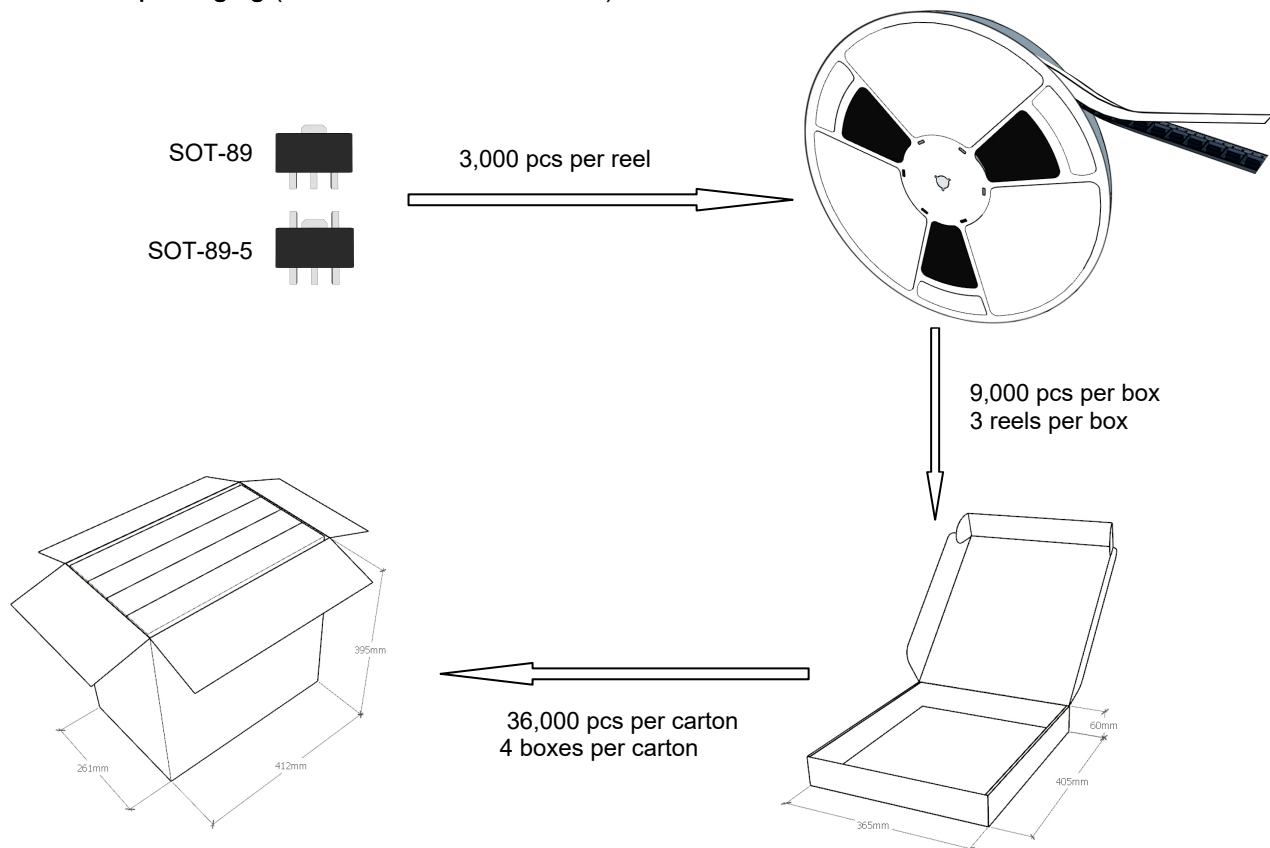

◆ reel data

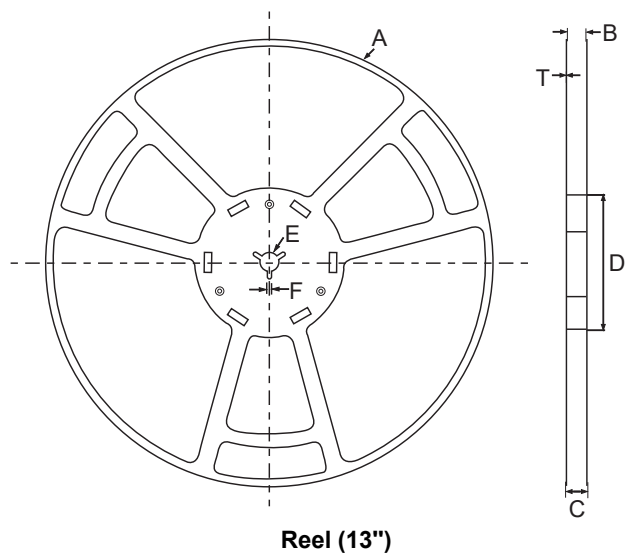

symbol	Value(unit:mm)
A	$\phi 330\pm 1$
B	12.7 ± 0.5
C	16.5 ± 0.3
D	$\phi 99.5\pm 0.5$
E	$\phi 13.6\pm 0.3$
F	2.8 ± 0.3
T	1.9 ± 0.2

◆ Embossed tape data

SOT-23

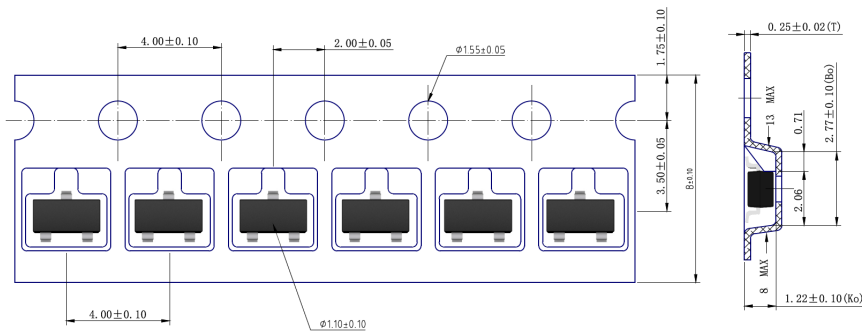

SOT-23-3

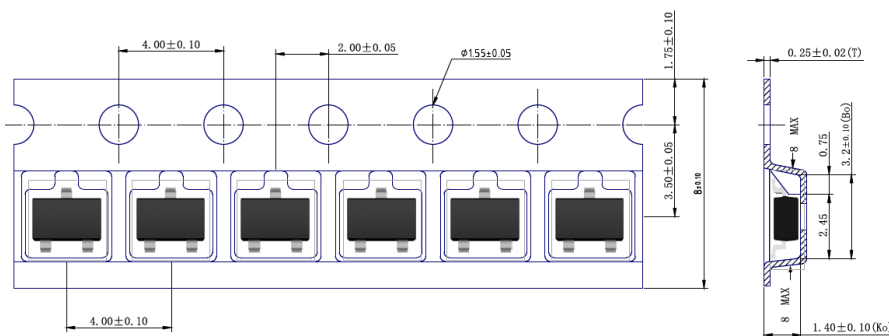

SOT-89

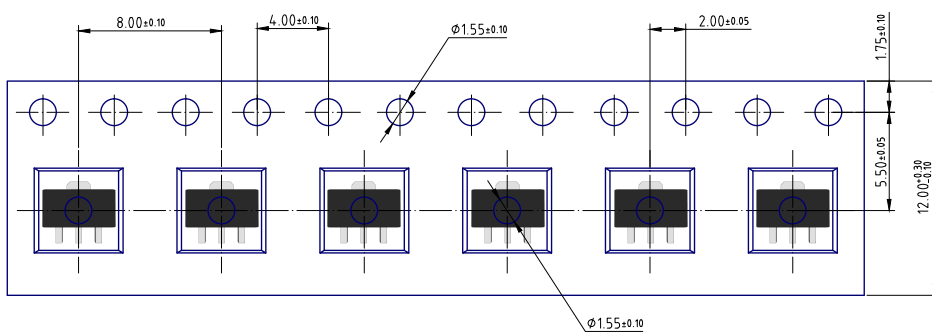

SOT-89-5

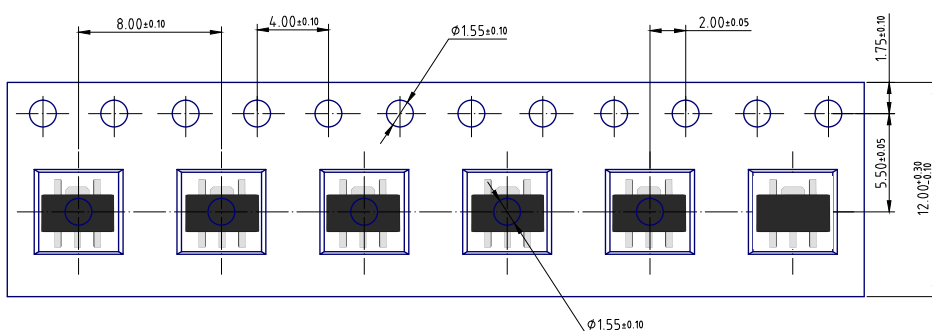

◆ Embossed tape data

SOT-23-5

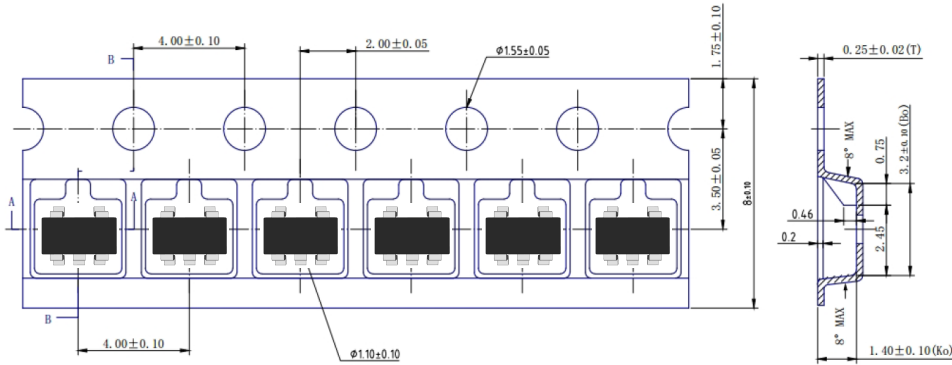

DFN1x1-4L

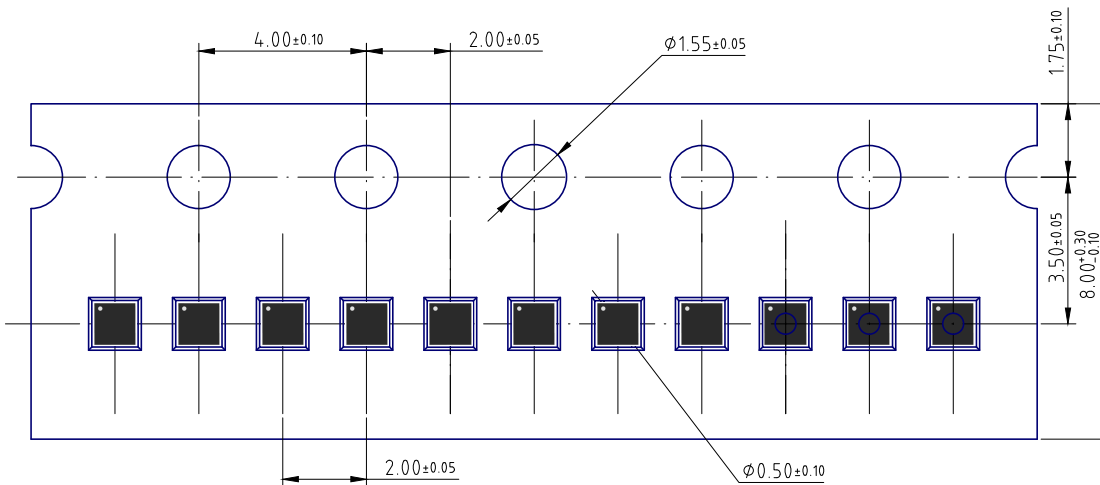

DFN2x2C-6L

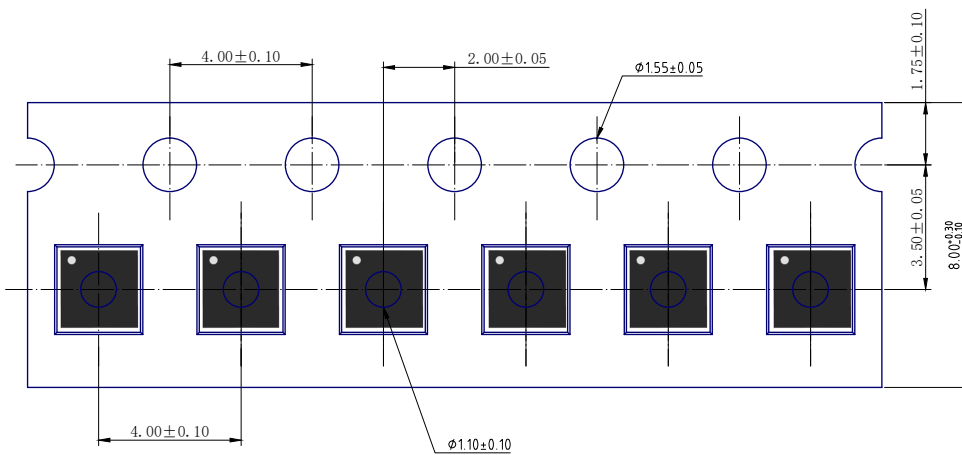

X-ON Electronics

Largest Supplier of Electrical and Electronic Components

Click to view similar products for [LDO Voltage Regulators](#) category:

Click to view products by [Pingjingsemi](#) manufacturer:

Other Similar products are found below :

[AP7363-SP-13](#) [NCV8664CST33T3G](#) [L79M05TL-E](#) [AP7362-HA-7](#) [PT7M8202B12TA5EX](#) [TCR3DF185,LM\(CT](#) [TLF4949EJ](#)
[NCP4687DH15T1G](#) [NCV8703MX30TCG](#) [LP2951CN](#) [NCV4269CPD50R2G](#) [AP7315-25W5-7](#) [NCV47411PAAJR2G](#) [AP2111H-1.2TRG1](#)
[ZLDO1117QK50TC](#) [AZ1117ID-ADJTRG1](#) [NCV4263-2CPD50R2G](#) [NCP114BMX075TCG](#) [MC33269T-3.5G](#) [TLE4471GXT](#) [AP7315-33SA-](#)
[7](#) [NCV4266-2CST33T3G](#) [NCP715SQ15T2G](#) [NCV8623MN-50R2G](#) [NCV563SQ18T1G](#) [NCV8664CDT33RKG](#) [NCV4299CD250R2G](#)
[NCV8702MX25TCG](#) [TLE7270-2E](#) [NCV562SQ25T1G](#) [AP2213D-3.3TRG1](#) [AP2202K-2.6TRE1](#) [NCV8170BMX300TCG](#)
[NCV8152MX300180TCG](#) [NCP700CMT45TBG](#) [AP7315-33W5-7](#) [NCP154MX180300TAG](#) [AP2210K-3.0TRE1](#) [AP2113AMTR-G1](#)
[NJW4104U2-33A-TE1](#) [MP2013AGG-5-P](#) [NCV8775CDT50RKG](#) [NJM2878F3-45-TE1](#) [S-19214B00A-V5T2U7](#) [S-19214B50A-V5T2U7](#) [S-](#)
[19213B50A-V5T2U7](#) [S-19214BC0A-E8T1U7*1](#) [S-19213B00A-V5T2U7](#) [S-19213B33A-V5T2U7](#) [S-19213BC0A-V5T2U7](#)