



Description

The PJ56 Series is a high input voltage, low quiescent current, low-dropout linear regulator able to provide 150mA load current. The LDO features very fast response against line voltage transient and load current transient, and ensures no overshoot voltage during the LDO start up and short circuit recovery.

The device features integrated short-circuit and thermal shutdown protection.

Features

- High Input Voltage Rating: Up to 80V
- Maximum Output Current: 150mA
- Standard Fixed Output Voltage Options: 3V, 3.3V, 3.6V, 5V
- Low Quiescent Current: 2.0uA
- High PSRR: 70dB at 1KHz
- Low Dropout: 700mV @ 100mA
- Low Output Voltage Accuracy: $\pm 2\%$
- Fast Transient Response
- Current Limiting Protection
- Thermal Shutdown Protection
- Available Packages: SOT-23-3, SOT-89, SOT-23-5 and TO-252

Applications

- Battery-Powered Equipment
- Smoke Detector and Sensor
- Micro Controller Applications

Typical Application Circuit

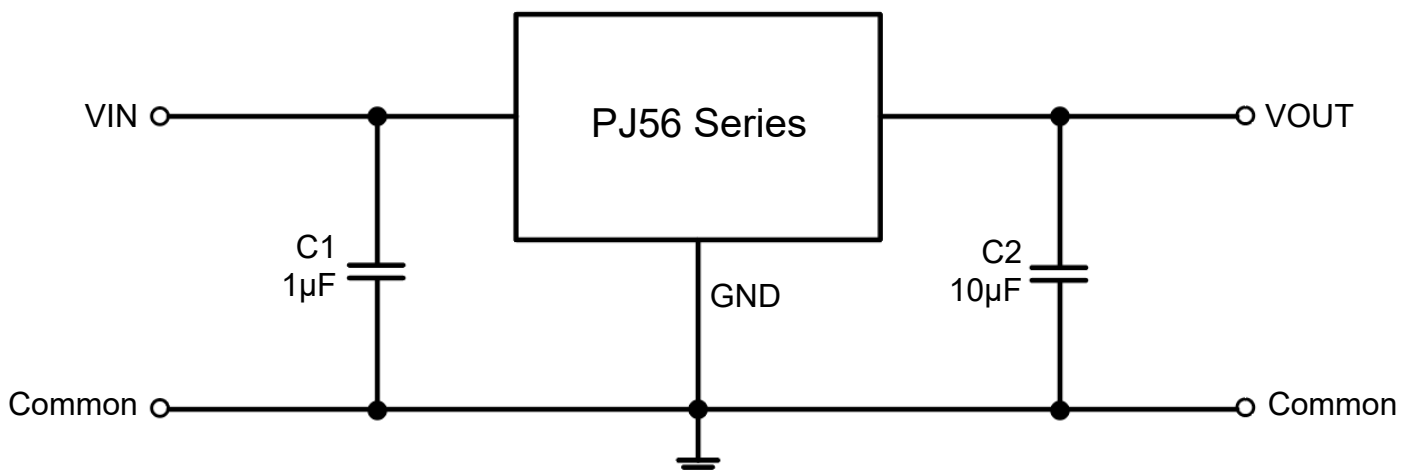

Pin Distribution

SOT-23-3

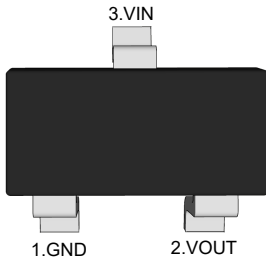

(Top View)

SOT-89

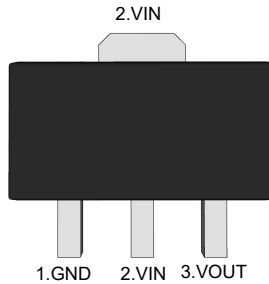

(Top View)

SOT-23-5

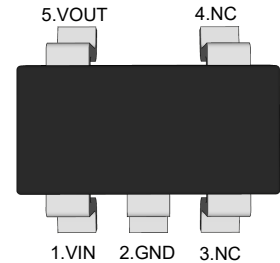

(Top View)

TO-252

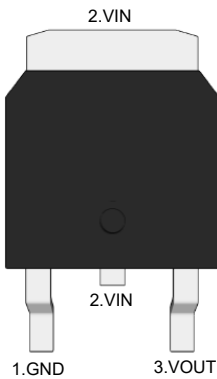

(Top View)

SOT-89

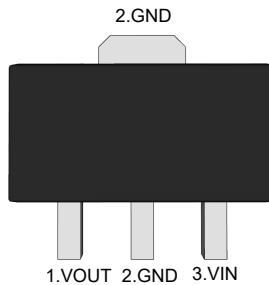

(Top View)

PJ56-A Series

TO-252

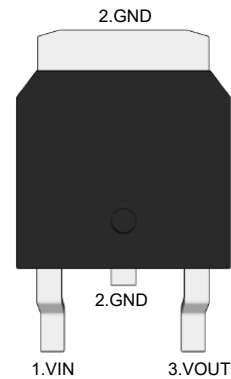

(Top View)

PJ56-A Series

Functional Pin Description

Pin Name	Pin Function
NC	NO Connected
GND	Ground
VOUT	Output Voltage
VIN	Power Input Voltage



Ordering Information

PJ56 □□□□□

Pin arrangement version number
 □(Blank): Normal pin arrangement version
 A: A version pin arrangement

Package Type
 SC : SOT-23-3 SE : SOT-23-5
 SQ : SOT-89 TE : TO-252

Output Voltage
 30 : 3.0V 33 : 3.3V
 36 : 3.6V 50 : 5.0V

Output current tap
 L: 150mA

Series NO.

Orderable Device	Package	Reel (inch)	Package Qty (PCS)	Eco Plan ^{Note1}	MSL Level	Marking Code
PJ56L30SC	SOT-23-3	7	3000	RoHS & Green	MSL3	<p>XX:Output Voltage e.g. 30:3.0V</p>
PJ56L33SC						
PJ56L36SC						
PJ56L50SC						
PJ56L30SQ	SOT-89	7/13	1000/3000	RoHS & Green	MSL1	<p>XX:Output Voltage e.g. 30:3.0V</p>
PJ56L33SQ						
PJ56L36SQ						
PJ56L50SQ						
PJ56L30SQ-A						<p>XX:Output Voltage e.g. 30:3.0V</p>
PJ56L33SQ-A						
PJ56L36SQ-A						
PJ56L50SQ-A						



PJ56 Series Low Dropout Regulators

Ordering Information Continue

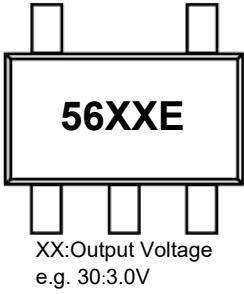
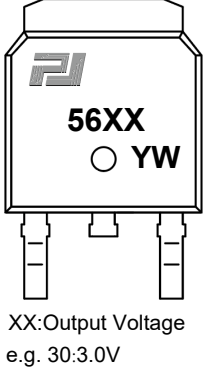
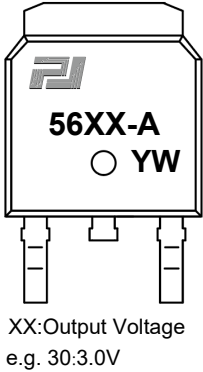
Orderable Device	Package	Reel (inch)	Package Qty (PCS)	Eco Plan ^{Note1}	MSL Level	Marking Code
PJ56L30SE	SOT-23-5	7	3000	RoHS & Green	MSL3	
PJ56L33SE						
PJ56L36SE						
PJ56L50SE						
PJ56L30TE	TO-252	13	2500	RoHS & Green	MSL3	
PJ56L33TE						
PJ56L36TE						
PJ56L50TE						
PJ56L30TE-A						
PJ56L33TE-A						
PJ56L36TE-A						
PJ56L50TE-A						

Note1:

RoHS: PJ defines "RoHS" to mean semiconductor products that are compliant with the current EU RoHS requirements for all 10 RoHS substances, including the requirement that RoHS substance do not exceed 0.1% by weight in homogeneous materials.

Green: PJ defines "Green" to mean Halogen-Free and Antimony-Free.

Function Block Diagram

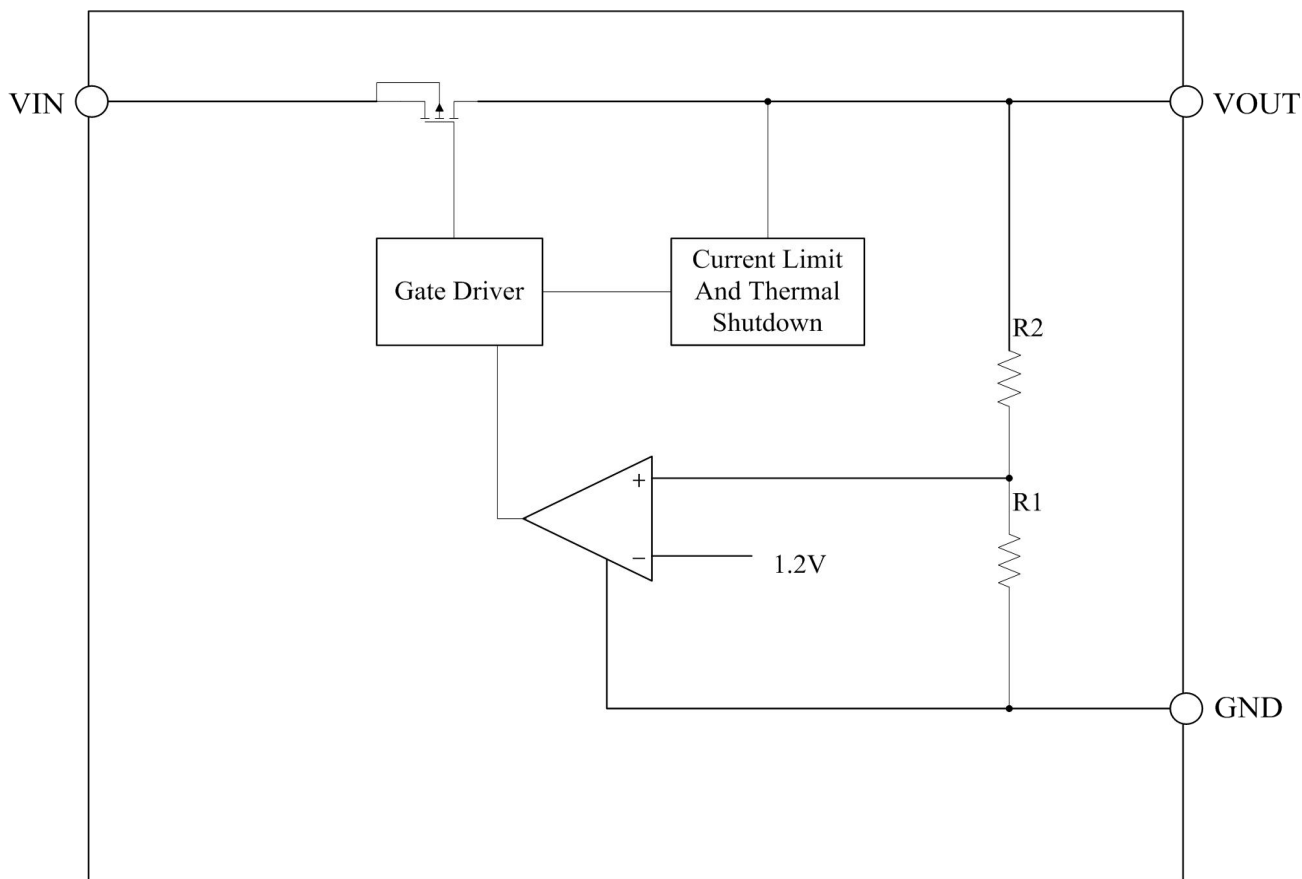



Absolute Maximum Ratings

Ratings at 25°C ambient temperature unless otherwise specified.

Parameter		Value	Unit
VIN to GND Voltage		-0.3 ~ +80	V
VOUT to GND Voltage		-0.3 ~ +6	V
VOUT to VIN Voltage		-35 ~ +0.3	V
Output Current		Internally limited	--
Power Dissipation	SOT-23-3	400	mW
	SOT-89	600	mW
	SOT-23-5	400	mW
	TO-252	2000	mW
Thermal Resistance, Junction-to-Ambient	SOT-23-3	300	°C/W
	SOT-89	180	°C/W
	SOT-23-5	300	°C/W
	TO-252	50	°C/W
Operating Ambient Temperature		-40 ~ +85	°C
Junction temperature		150	°C
Storage temperature range		-40 ~ +150	°C
ESD Voltage	HBM	4	KV
	MM	100	V

Note1: Exceed these limits to damage to the device. Exposure to absolute maximum rating conditions may affect.

Recommended Operating Conditions

Parameter	Value	Unit
Supply Voltage	5~60	V
Maximum Output Current	150	mA
Operating Ambient Temperature	-40 ~ +85	°C



Electrical Characteristics

($V_{IN}=V_{OUT}+1$, $C_{IN}=1\mu F$, $C_{OUT}=10\mu F$, $T_A=25^\circ C$, unless otherwise noted.)

Parameter	Symbol	Test Conditions	Min.	Typ.	Max.	Unit
Input Voltage	V_{IN}		5	--	60	V
Output Voltage Accuracy	ΔV_{OUT}	$V_{IN}=12V$, $I_{OUT}=10mA$	-2	--	+2	%
Quiescent Current	I_Q	$V_{IN}=12V$, $I_{OUT}=0mA$	--	2	--	μA
Maximum Output Current	I_{OUT_Max}		--	150	--	mA
Dropout Voltage ^{Note2}	V_{DROP}	$V_{IN}=V_{OUTNOM}-0.1V$, $I_{OUT}=10mA$	--	--	150	mV
		$V_{IN}=V_{OUTNOM}-0.1V$, $I_{OUT}=100mA$	--	--	700	
Line Regulation	ΔV_{LINE}	$I_{OUT}=1mA$, $V_{OUTNOM}+0.5V \leq V_{IN} \leq 60V$	--	0.01	--	%/V
Load Regulation	ΔV_{LOAD}	$V_{IN}=12V$, $1mA < I_{OUT} < 100mA$	--	0.02	--	%/mA
Current Limit	I_{LIM}		--	220	--	mA
Power Supply Rejection Ratio	PSRR	$V_{IN}=12V$, $I_{OUT}=10mA$ $f=1KHz$, $V_{OUT}=3.3V$	--	70	--	dB
Output Noise Voltage	e_N	$V_{IN}=10V$, $I_{OUT}=1mA$ $f=10Hz$ to $100KHz$, $V_{OUT}=3.3V$	--	440	--	μV_{rms}
Thermal Shutdown Temperature	T_{SHDN}	Shutdown, Temp increasing	--	150	--	$^\circ C$
Thermal Reset Temperature		Reset, Temp decreasing	--	115	--	$^\circ C$

Note2:

Dropout Voltage is the voltage difference between the input and the output at which the output voltage drops 2% below its nominal value.



Typical Characteristic Curves

(Test Condition: $T_A=25^{\circ}\text{C}$, $I_{\text{OUT}}=1\text{mA}$, $C_{\text{OUT}}=10\mu\text{F}$, unless otherwise noted.)

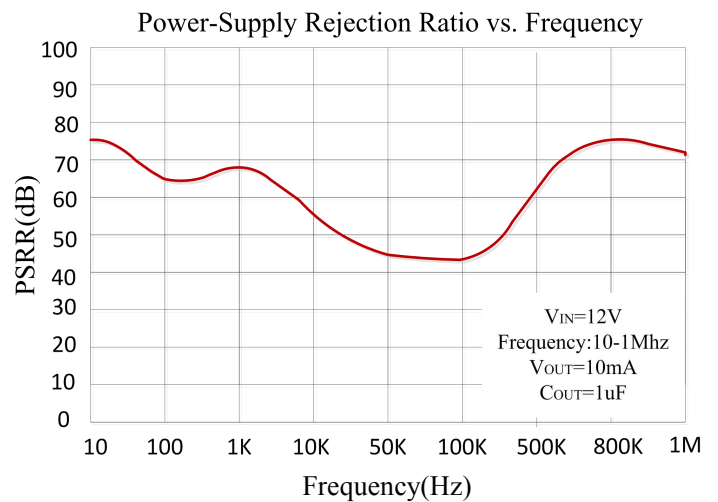
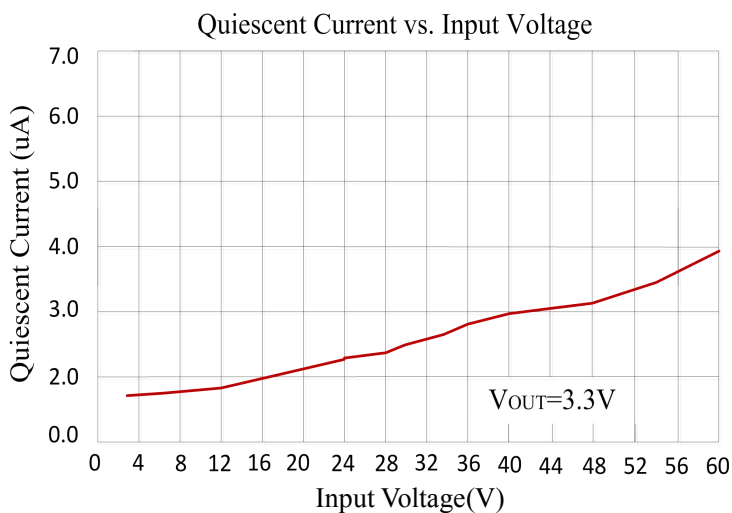
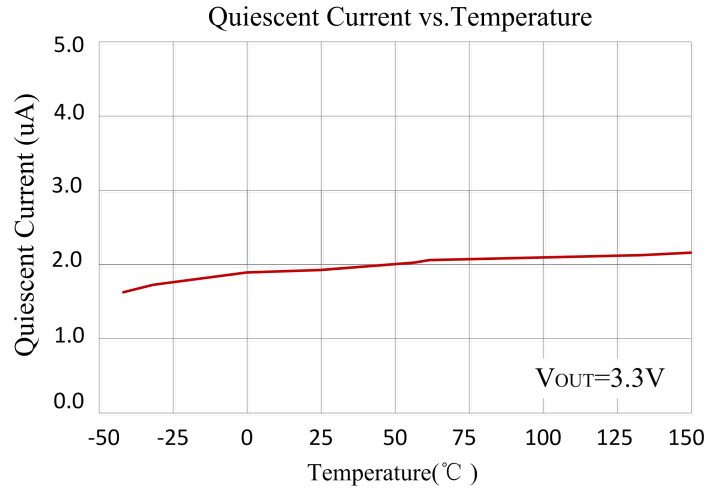
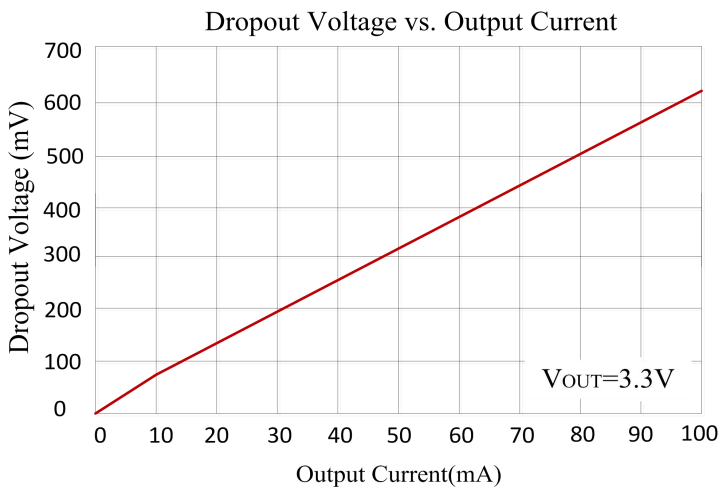
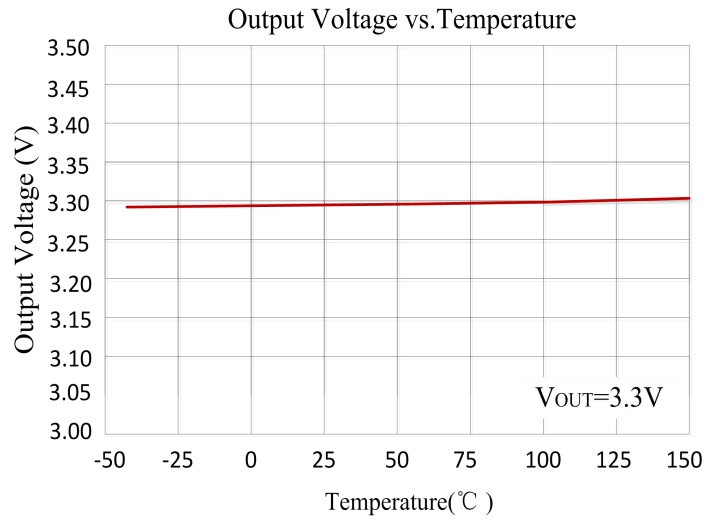
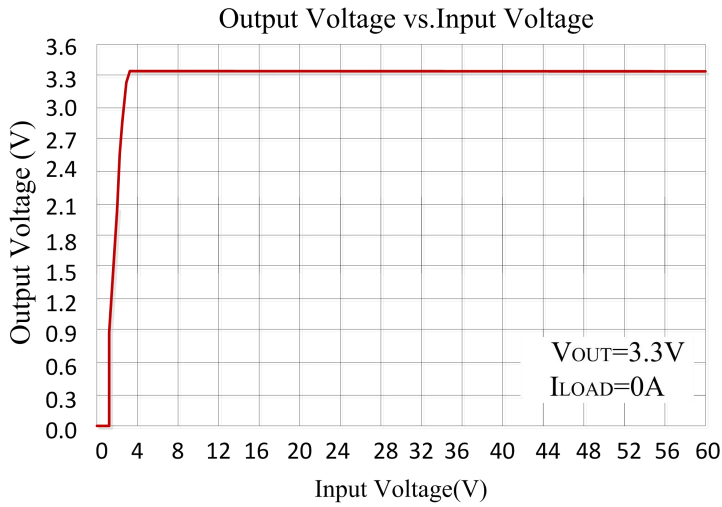



PJ56 Series Low Dropout Regulators

Line Transient Response

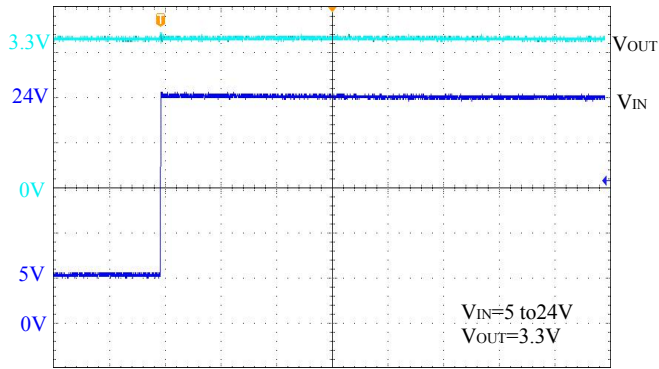

Time(10us/div)

Line Transient Response

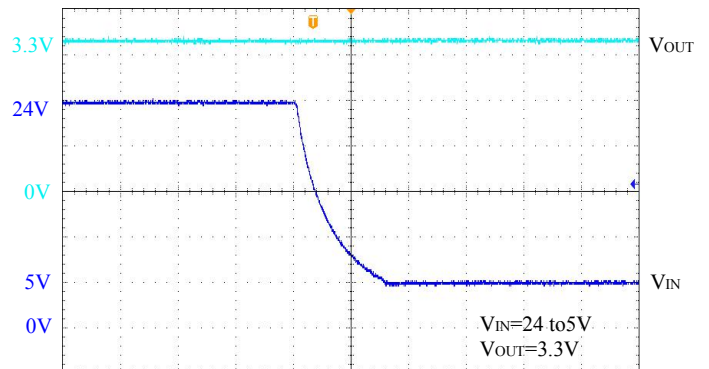

Time(4us/div)

Load Transient Response

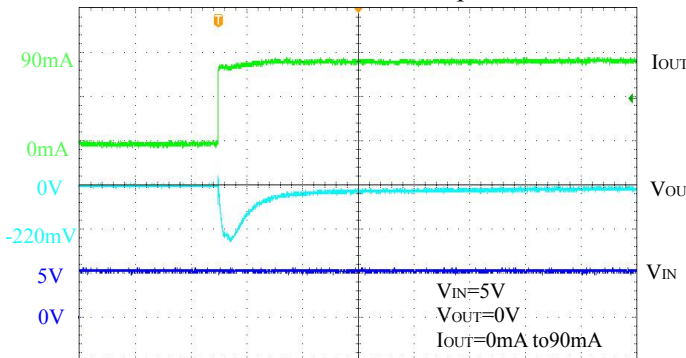

Time(20us/div)

Load Transient Response

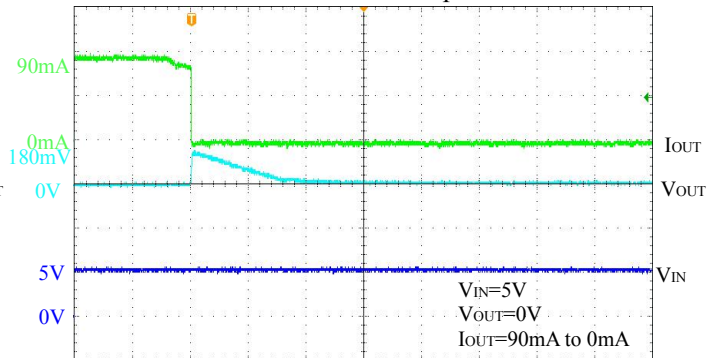

Time(200us/div)

Start Up

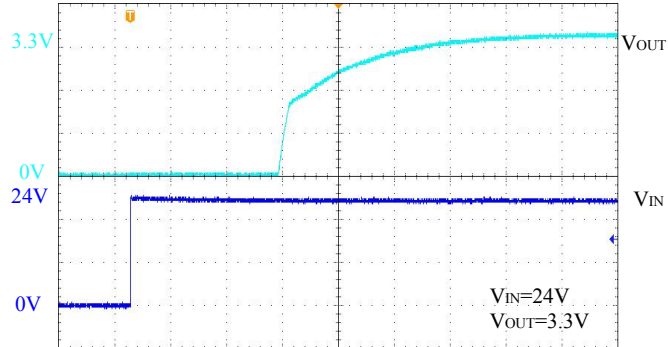

Time(100us/div)

Start Up

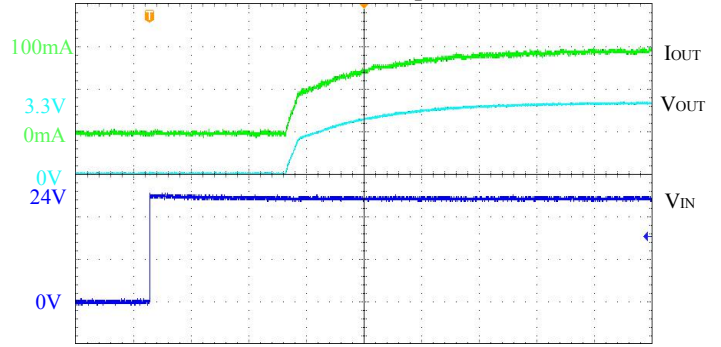

Time(100us/div)

Short Circuit Protection

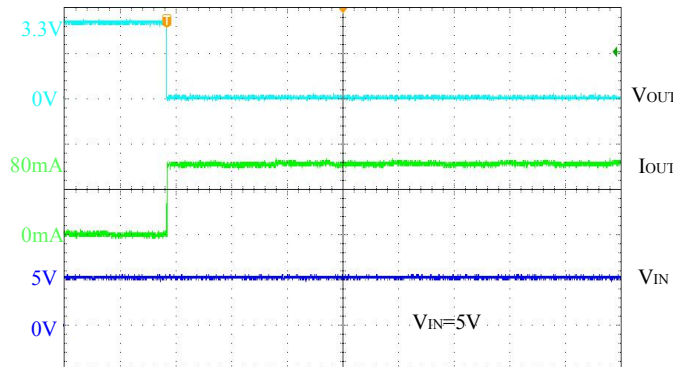

Time(10ms/div)

Short Circuit Protection

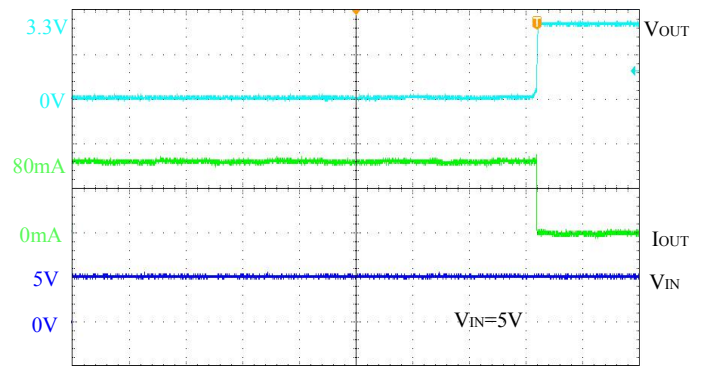

Time(10ms/div)



Functional Description

Input Capacitor

A 1 μ F ceramic capacitor is recommended to connect between VIN and GND pins to decouple input power supply glitch and noise. The amount of the capacitance may be increased without limit. This input capacitor must be located as close as possible to the device to assure input stability and less noise. For PCB layout, a wide copper trace is required for both VIN and GND.

Output Capacitor

An output capacitor is required for the stability of the LDO. The recommended minimum output capacitance is 10 μ F, ceramic capacitor is recommended, and temperature characteristics are X7R or X5R. Higher capacitance values help to improve load/line transient response. The output capacitance may be increased to keep low undershoot/overshoot. Place output capacitor as close as possible to VOUT and GND pins.

Current Limit and Short Circuit Protection

When output current at VOUT pin is higher than current limit threshold or the VOUT pin is direct short to GND, the current limit protection will be triggered and clamp the output current at a pre-designed level to prevent over-current and thermal damage.

Thermal Protection

The PJ56 Series has internal thermal sense and protection circuits. When excessive power dissipation happens on the device, such as short circuit at the output pin or very heavy load current with a large voltage drop across the device, the internal thermal protection circuit will be triggered, and it will shut down the power MOSFET to prevent the LDO from damage. As soon as excessive thermal condition is removed and the temperature of the device drops down, the thermal protection circuit will lease the control of the power MOSFET, and the LDO device goes to normal operation.



Package Outline

SOT-23-3

Dimensions in mm

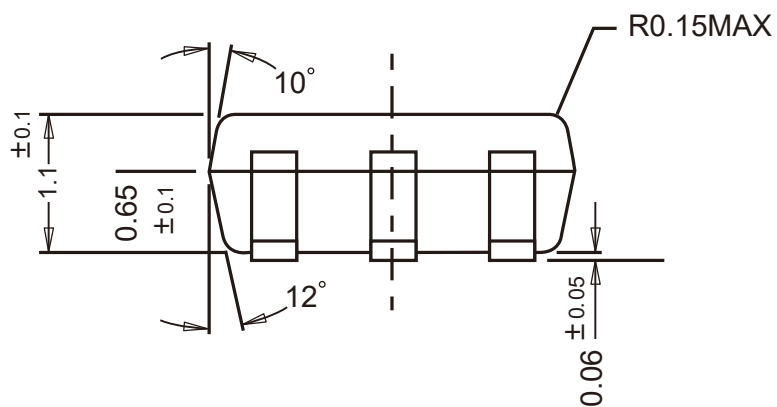
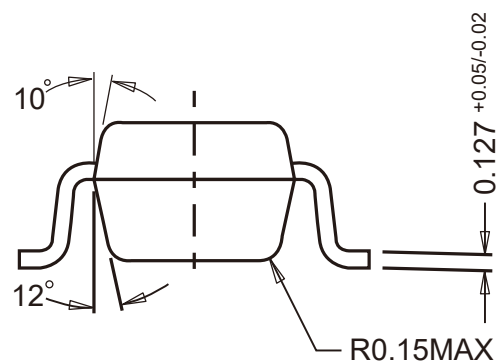
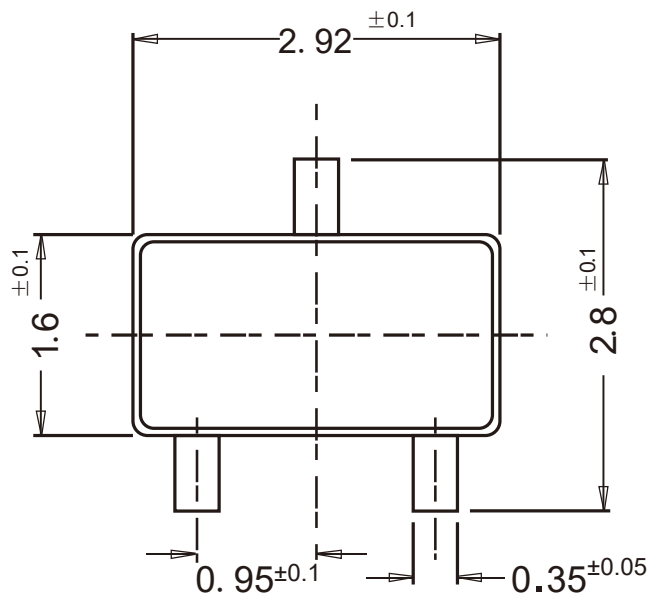

Package Outline

SOT-89

Dimensions in mm

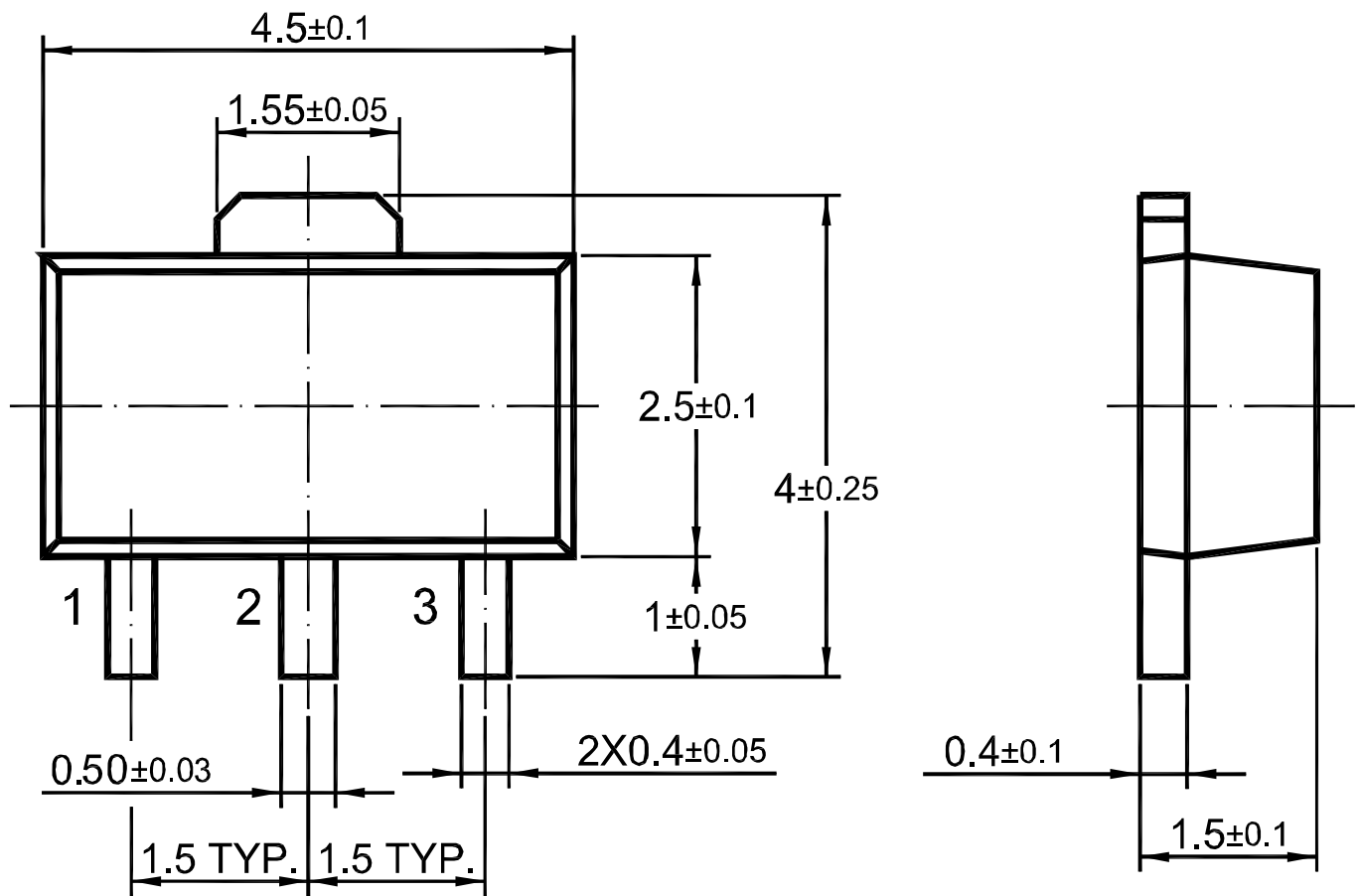



Package Outline

SOT-23-5

Dimensions in mm

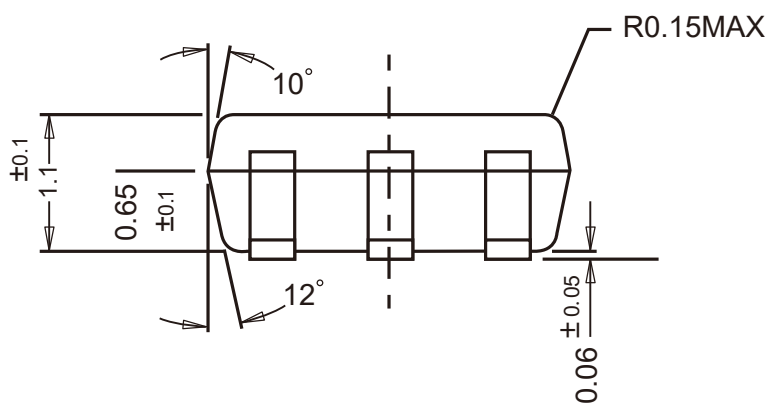
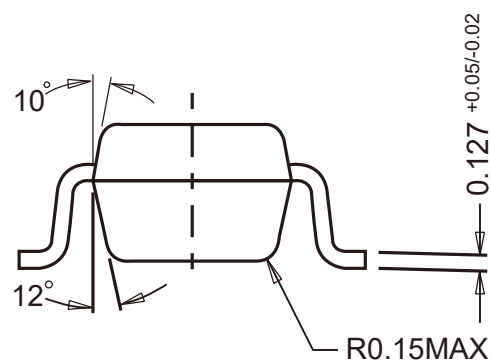
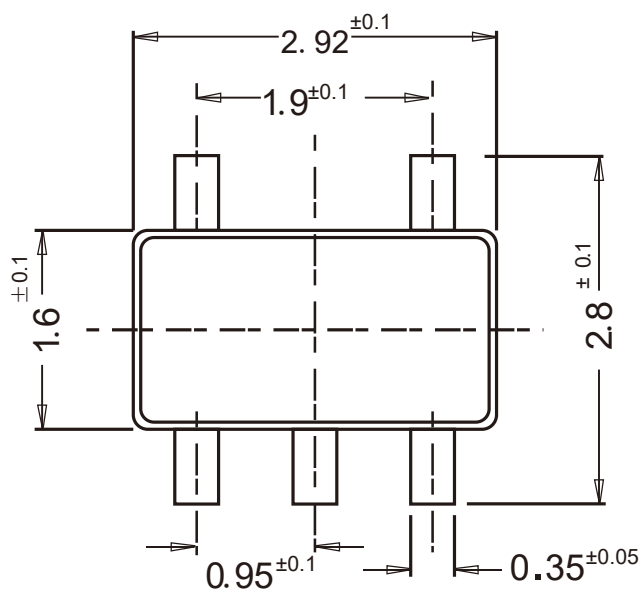



Package Outline

TO-252

Dimensions in mm

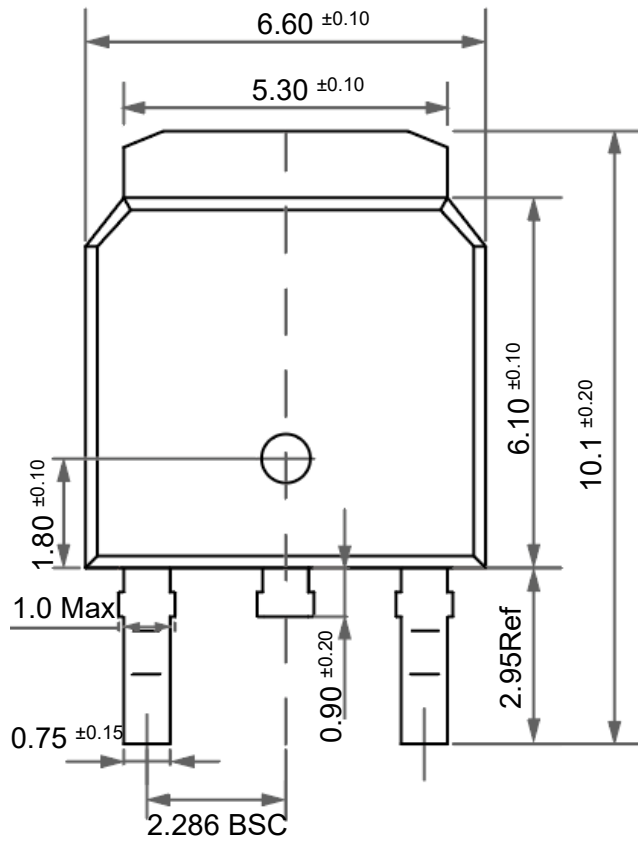

Front View

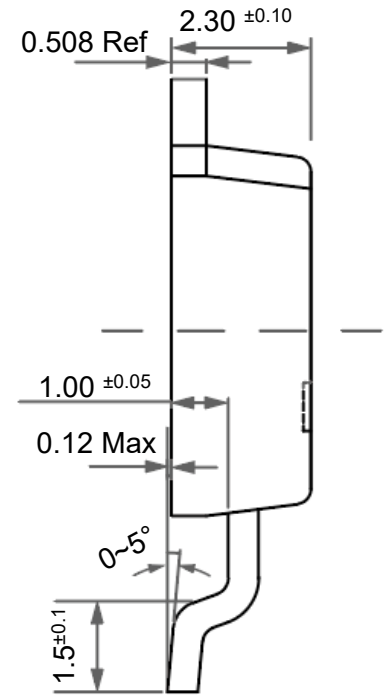

Side View

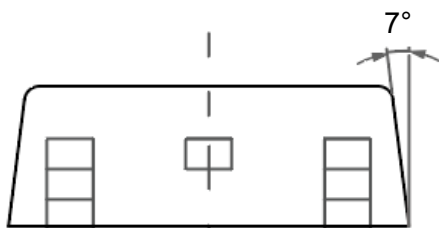

Bottom View

Conditions of Soldering and Storage

◆ Recommended condition of reflow soldering

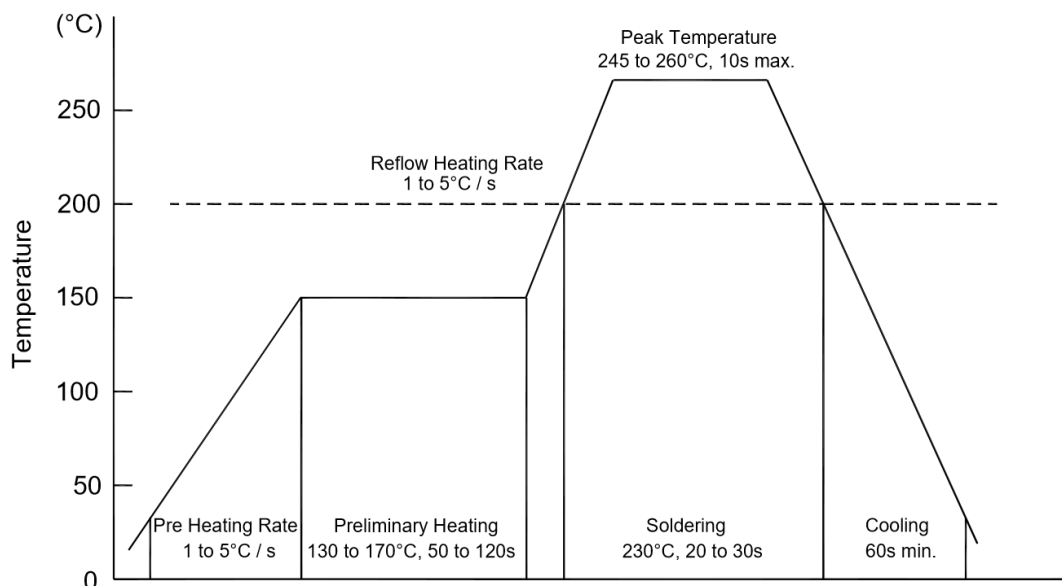

Recommended peak temperature is over 245°C. If peak temperature is below 245°C, you may adjust the following parameters:

- Time length of peak temperature (longer)
- Time length of soldering (longer)
- Thickness of solder paste (thicker)

◆ Conditions of hand soldering

- Temperature: 300°C
- Time: 3s max.
- Times: one time

◆ Storage conditions

- **Temperature**
5 to 40°C
- **Humidity**
30 to 80% RH
- **Recommended period**
One year after manufacturing

Package Specifications (SOT-23/SOT-23-3/SOT-23-5/DFN2x2C-6L)

- The method of packaging

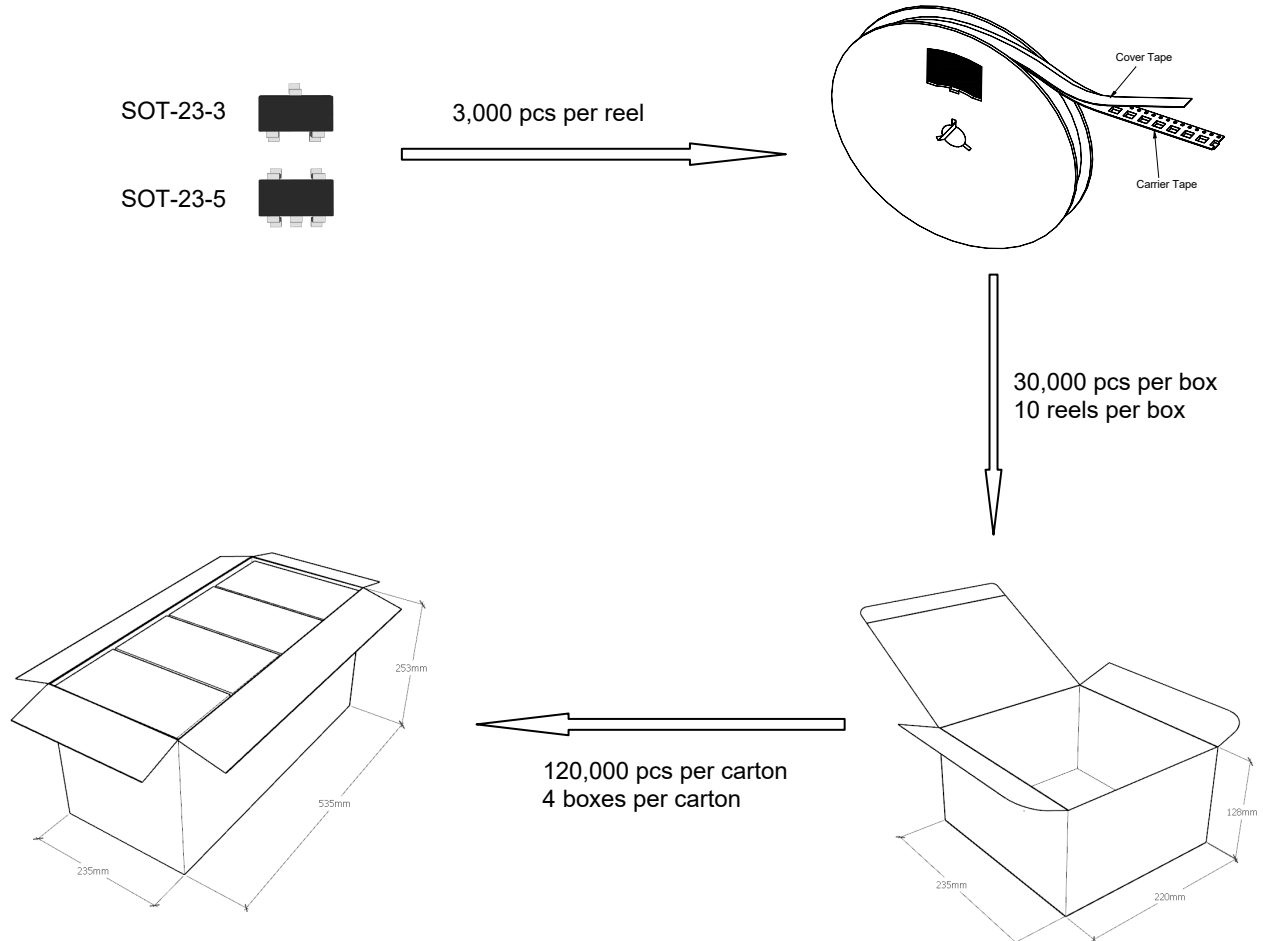

◆ Embossed tape and reel data

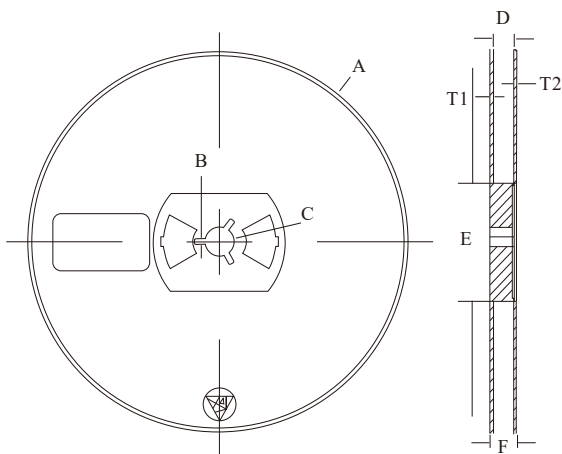

Reel (7")

Symbol	Value (unit: mm)
A	Ø 177.8±1
B	2.7±0.2
C	Ø 13.5±0.2
E	Ø 54.5±0.2
F	12.3±0.3
D	9.6+2/-0.3
T1	1.0±0.2
T2	1.2±0.2

Package Specifications (SOT-89)

- The method of packaging (1,000PCS/Reel&7inches)

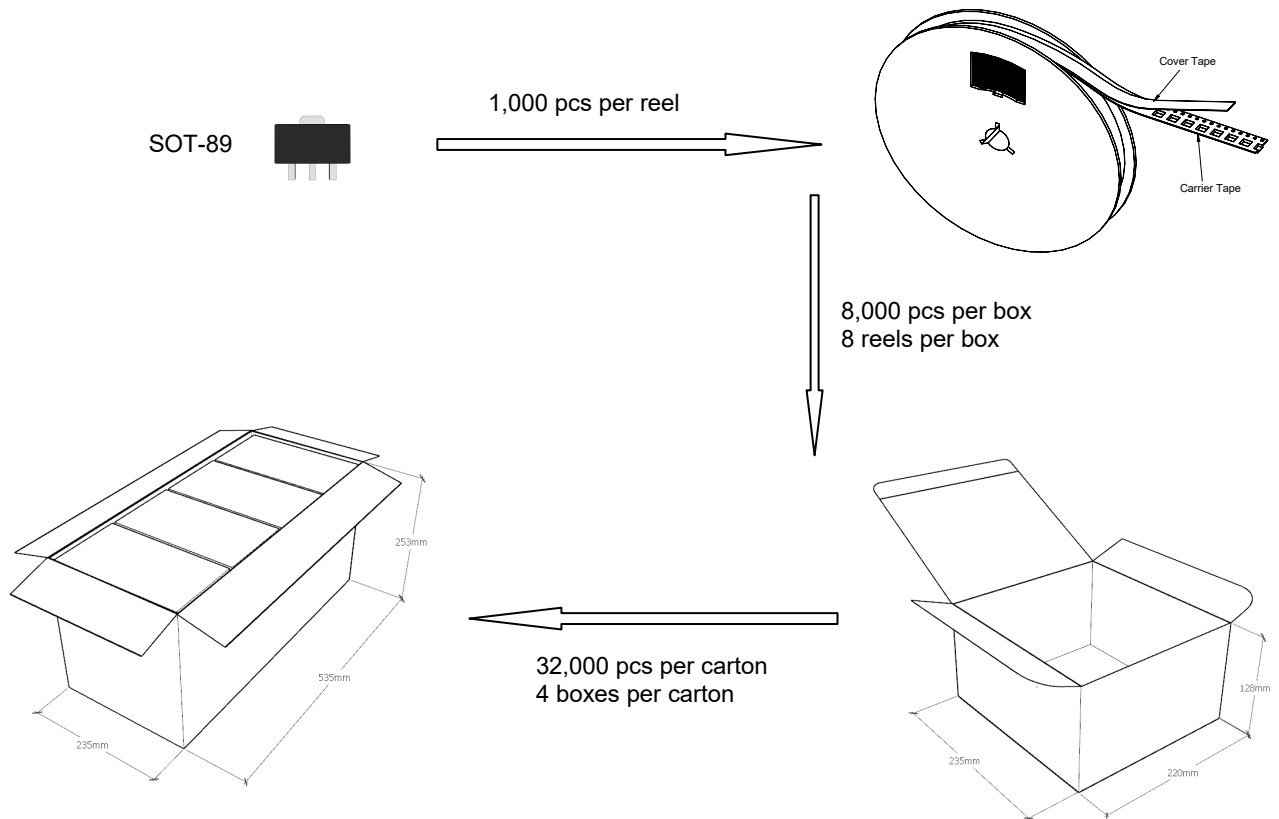

◆ reel data

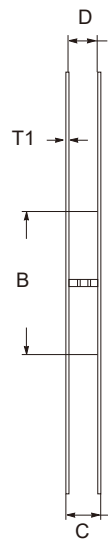
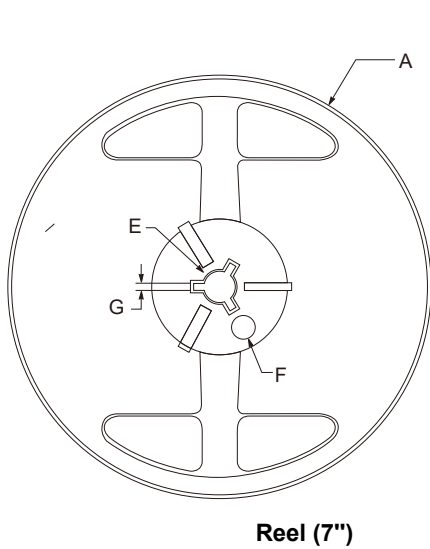

symbol	Value(unit:mm)
A	$\Phi 179 \pm 1$
B	60.5 ± 0.2
C	15.3 ± 0.3
D	$12.5 \sim 13.7$
E	$\Phi 13.5 \pm 0.2$
F	$\Phi 10.0 \pm 0.2$
G	2.7 ± 0.2
T1	1.0 ± 0.2

Package Specifications (SOT-89)

- The method of packaging (3,000PCS/Reel&13inches)

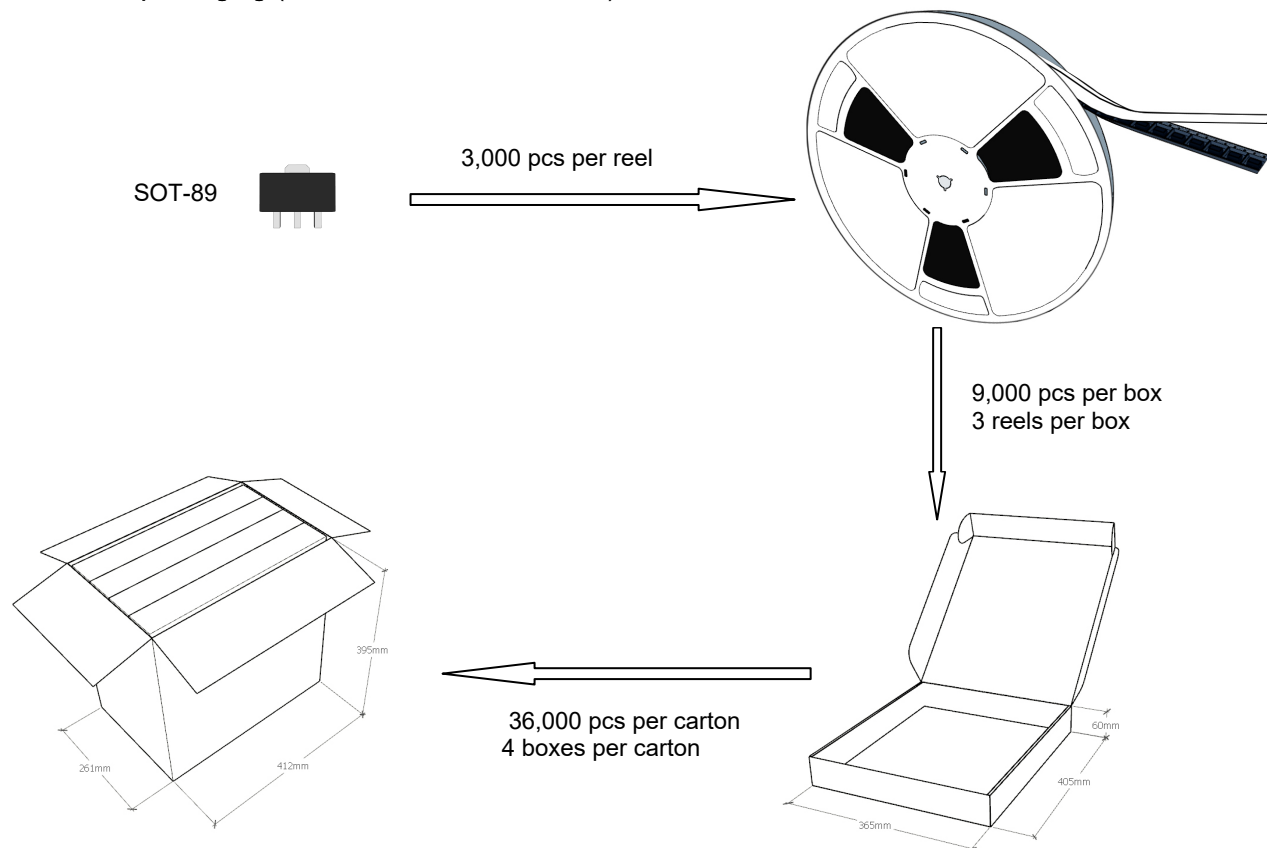

◆ reel data

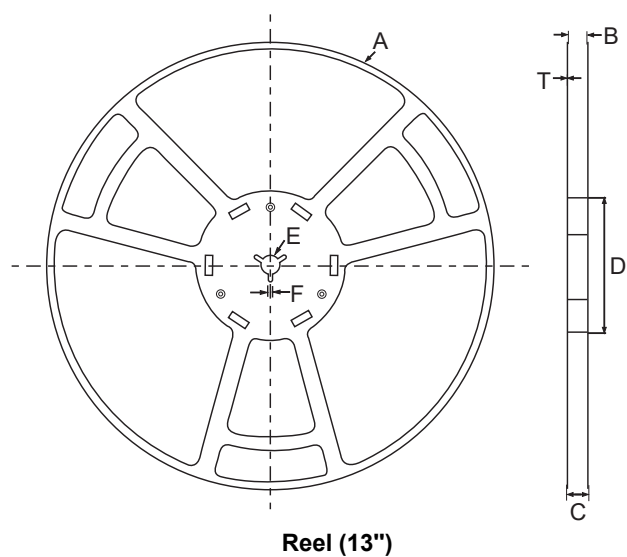

symbol	Value(unit:mm)
A	$\phi 330\pm 1$
B	12.7 ± 0.5
C	16.5 ± 0.3
D	$\phi 99.5\pm 0.5$
E	$\phi 13.6\pm 0.3$
F	2.8 ± 0.3
T	1.9 ± 0.2

Package Specifications (TO-252)

- The method of packaging

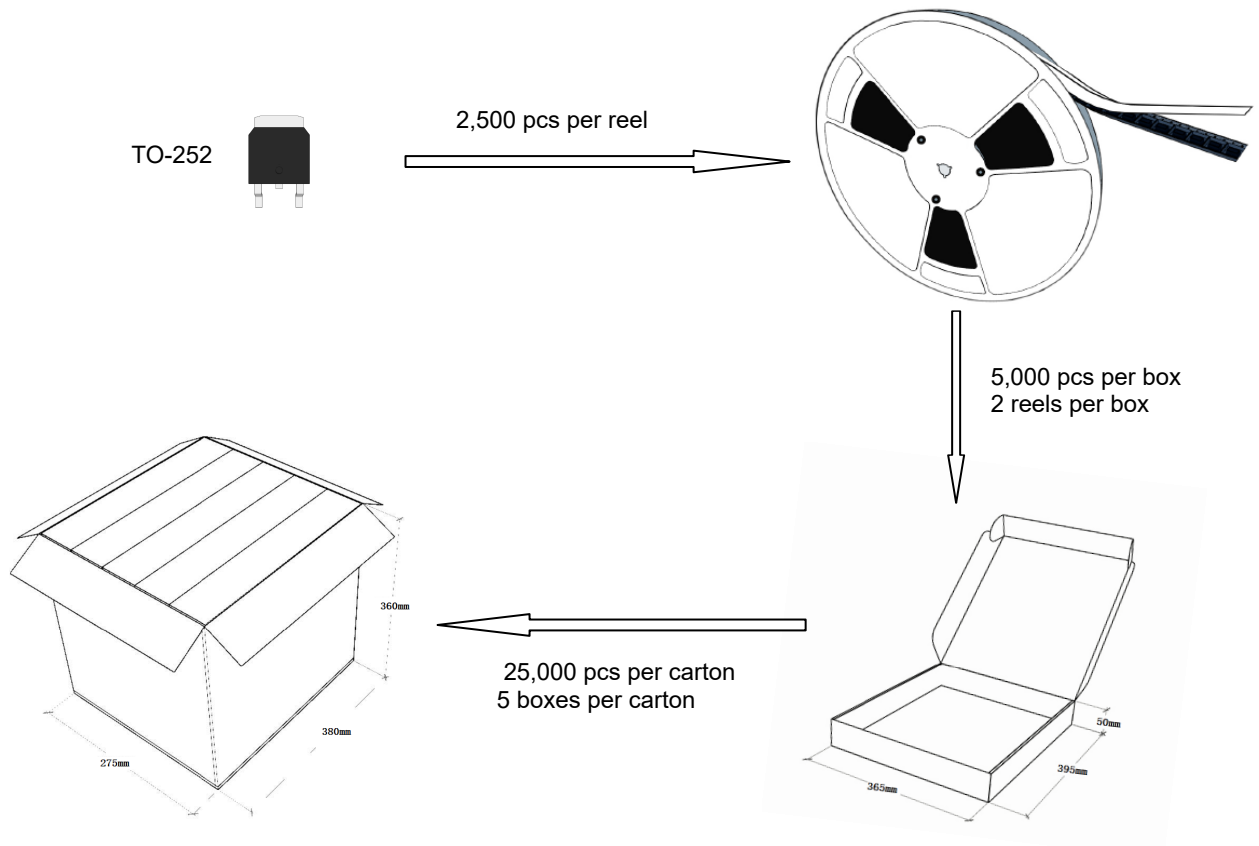

◆ reel data

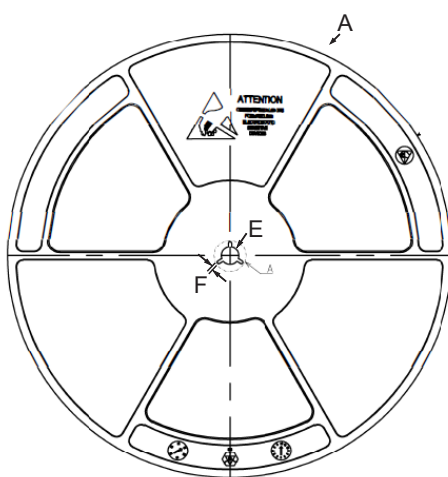

Symbol	Value(unit:mm)
A	$\Phi 330.2 \pm 1$
B	17 ± 0.5
C	21.2 ± 2
D	$\Phi 100 \pm 0.5$
E	$\Phi 13.4 \pm 0.2$
F	2.3 ± 0.2
T	2.1 ± 0.2

◆ Embossed tape data

SOT-23-3

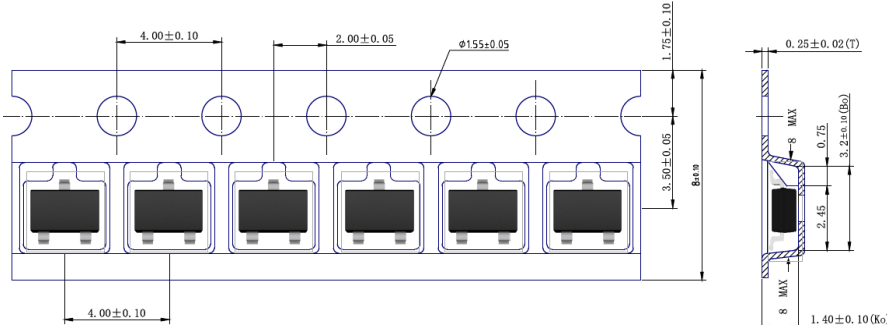

SOT-89

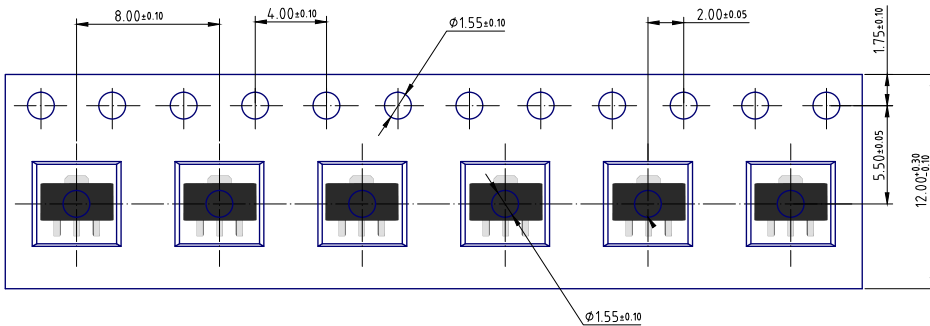

SOT-23-5

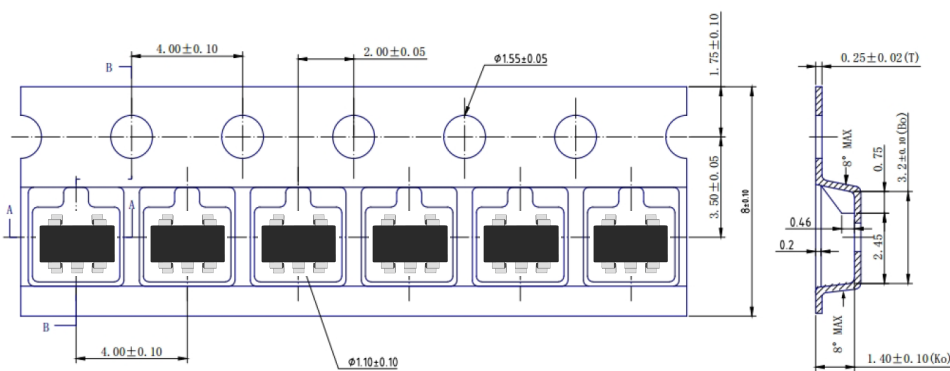

◆ Embossed tape data

TO-252

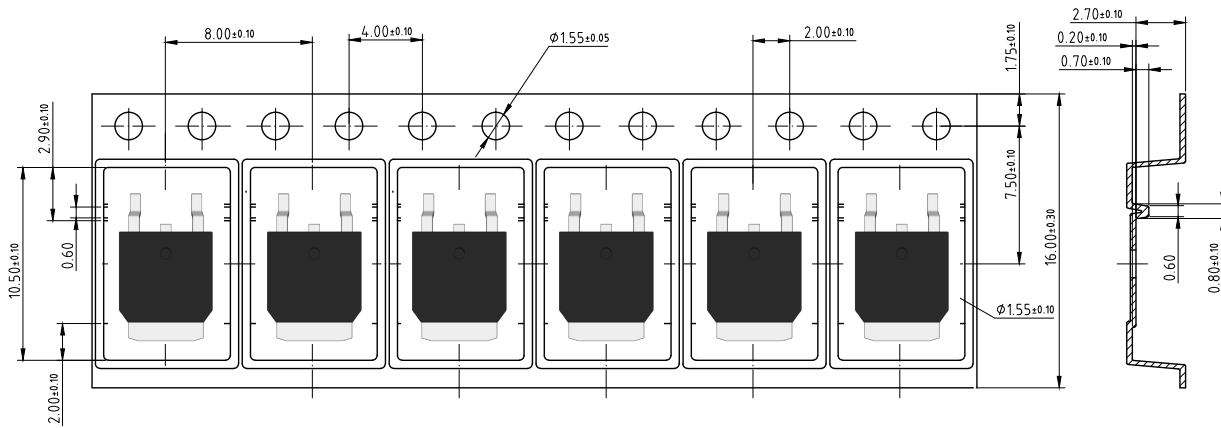

X-ON Electronics

Largest Supplier of Electrical and Electronic Components

Click to view similar products for [LDO Voltage Regulators](#) category:

Click to view products by [Pingjingsemi](#) manufacturer:

Other Similar products are found below :

[AP7363-SP-13](#) [NCV8664CST33T3G](#) [L79M05TL-E](#) [AP7362-HA-7](#) [PT7M8202B12TA5EX](#) [TCR3DF185,LM\(CT](#) [TLF4949EJ](#)
[NCP4687DH15T1G](#) [NCV8703MX30TCG](#) [LP2951CN](#) [NCV4269CPD50R2G](#) [AP7315-25W5-7](#) [NCV47411PAAJR2G](#) [AP2111H-1.2TRG1](#)
[ZLDO1117QK50TC](#) [AZ1117ID-ADJTRG1](#) [NCV4263-2CPD50R2G](#) [NCP114BMX075TCG](#) [MC33269T-3.5G](#) [TLE4471GXT](#) [AP7315-33SA-](#)
[7](#) [NCV4266-2CST33T3G](#) [NCP715SQ15T2G](#) [NCV8623MN-50R2G](#) [NCV563SQ18T1G](#) [NCV8664CDT33RKG](#) [NCV4299CD250R2G](#)
[NCV8702MX25TCG](#) [TLE7270-2E](#) [NCV562SQ25T1G](#) [AP2213D-3.3TRG1](#) [AP2202K-2.6TRE1](#) [NCV8170BMX300TCG](#)
[NCV8152MX300180TCG](#) [NCP700CMT45TBG](#) [AP7315-33W5-7](#) [NCP154MX180300TAG](#) [AP2210K-3.0TRE1](#) [AP2113AMTR-G1](#)
[NJW4104U2-33A-TE1](#) [MP2013AGG-5-P](#) [NCV8775CDT50RKG](#) [NJM2878F3-45-TE1](#) [S-19214B00A-V5T2U7](#) [S-19214B50A-V5T2U7](#) [S-](#)
[19213B50A-V5T2U7](#) [S-19214BC0A-E8T1U7*1](#) [S-19213B00A-V5T2U7](#) [S-19213B33A-V5T2U7](#) [S-19213BC0A-V5T2U7](#)