



Features

- Low power consumption
- Low voltage drop
- Low temperature coefficient
- High input voltage (up to 24V)

Applications

- Battery-powered equipment
- Communication equipment
- Audio/Video equipment

General Description

The PJ71KXXSC series is a set of three-terminal low power high voltage regulators implemented in CMOS technology. They allow input voltages as high as 24V. They are available with several fixed output voltages ranging from 3.0V to 5.0V. CMOS technology ensures low voltage drop and low quiescent current.

Although designed primarily as fixed voltage regulators, these devices can be used with external components to obtain variable voltages and currents.

SOT-23-3

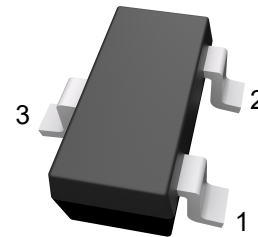

1.GND 2.VOUT 3.VIN

Block Diagram

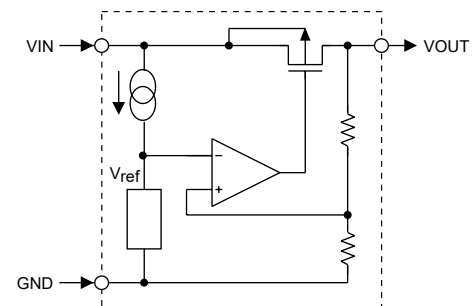

Selection Table

Part No.	Output Voltage	Tolerance
PJ71K30SC	3.0V	±5%
PJ71K33SC	3.3V	±5%
PJ71K36SC	3.6V	±5%
PJ71K44SC	4.4V	±5%
PJ71K50SC	5.0V	±5%



Absolute Maximum Ratings (Ta=25°C unless otherwise specified)

Symbol	Parameter	Rating	Units
V _{IN}	Supply Voltage	-0.3V to 28V	V
P _D	Power Dissipation	200	mW
T _{OPR}	Operating Ambient	-40 ~ +85	°C
T _{STG}	Storage Temperature	-65 ~ +125	°C

Note: These are stress ratings only. Stresses exceeding the range specified under Absolute Maximum Ratings may cause substantial damage to the device. Functional operation of this device at other conditions beyond those listed in the specification is not implied and prolonged exposure to extreme conditions may affect device reliability.

Electrical Characteristics

PJ71K30SC (Ta=25°C)

Symbol	Parameter	Test Conditions		Min.	Typ.	Max.	Units
		V _{IN}	Conditions				
V _{OUT}	Output Voltage	5V	I _{OUT} =10mA	2.85	3.0	3.15	V
I _{OUT}	Output Current	5V		20	30		mA
ΔV _{OUT}	Load Regulation	5V	1mA ≤ I _{OUT} ≤ 20mA		60	100	mV
V _D	Voltage Drop		I _{OUT} =1mA		100		mV
I _{SS}	Current Consumption	5V	No load		4	6.0	uA
$\frac{\Delta V_{OUT}}{\Delta V_{IN} \times V_{OUT}}$	Line Regulation		4V ≤ V _{IN} ≤ 24V I _{OUT} =1mA		0.2		%/V
V _{IN}	Input Voltage					24	V
$\frac{\Delta V_{OUT}}{\Delta T_a}$	Temperature Coefficient	5V	I _{OUT} =10mA 0°C < T _a < 70°C		±0.45		mV/°C

PJ71K33SC (Ta=25°C)

Symbol	Parameter	Test Conditions		Min.	Typ.	Max.	Units
		V _{IN}	Conditions				
V _{OUT}	Output Voltage	5.5V	I _{OUT} =10mA	3.135	3.3	3.465	V
I _{OUT}	Output Current	5.5V		20	30		mA
ΔV _{OUT}	Load Regulation	5.5V	1mA ≤ I _{OUT} ≤ 30mA		60	100	mV
V _D	Voltage Drop		I _{OUT} =1mA		100		mV
I _{SS}	Current Consumption	5.5V	No load		4	6	uA
$\frac{\Delta V_{OUT}}{\Delta V_{IN} \times V_{OUT}}$	Line Regulation		4.5V ≤ V _{IN} ≤ 24V I _{OUT} =1mA		0.2		%/V
V _{IN}	Input Voltage					24	V
$\frac{\Delta V_{OUT}}{\Delta T_a}$	Temperature Coefficient	5.5V	I _{OUT} =10mA 0°C < T _a < 70°C		±0.5		mV/°C



PJ71KXXSC Series

Low Dropout Regulators

PJ71K36SC (Ta=25°C)

Symbol	Parameter	Test Conditions		Min.	Typ.	Max.	Units
		V _{IN}	Conditions				
V _{OUT}	Output Voltage	5.6V	I _{OUT} =10mA	3.42	3.6	3.78	V
I _{OUT}	Output Current	5.6V		20	30		mA
ΔV _{OUT}	Load Regulation	5.6V	1mA ≤ I _{OUT} ≤ 30mA		60	100	mV
V _D	Voltage Drop		I _{OUT} =1mA		60		mV
I _{SS}	Current Consumption	5.6V	No load		3.0	7.0	uA
$\frac{\Delta V_{OUT}}{\Delta V_{IN} \times V_{OUT}}$	Line Regulation		4.6V ≤ V _{IN} ≤ 24V I _{OUT} =1mA		0.2		%/V
V _{IN}	Input Voltage					24	V
$\frac{\Delta V_{OUT}}{\Delta T_a}$	Temperature Coefficient	5.6V	I _{OUT} =10mA 0°C < T _a < 70°C		±0.6		mV/°C

PJ71K44SC (Ta=25°C)

Symbol	Parameter	Test Conditions		Min.	Typ.	Max.	Units
		V _{IN}	Conditions				
V _{OUT}	Output Voltage	6.4V	I _{OUT} =10mA	4.18	4.4	4.62	V
I _{OUT}	Output Current	6.4V		20	30		mA
ΔV _{OUT}	Load Regulation	6.4V	1mA ≤ I _{OUT} ≤ 30mA		60	100	mV
V _D	Voltage Drop		I _{OUT} =1mA		100		mV
I _{SS}	Current Consumption	6.4V	No load		4	7.5	uA
$\frac{\Delta V_{OUT}}{\Delta V_{IN} \times V_{OUT}}$	Line Regulation		5.4V ≤ V _{IN} ≤ 24V I _{OUT} =1mA		0.2		%/V
V _{IN}	Input Voltage					24	V
$\frac{\Delta V_{OUT}}{\Delta T_a}$	Temperature Coefficient	6.4V	I _{OUT} =10mA 0°C < T _a < 70°C		±0.7		mV/°C

PJ71K50SC (Ta=25°C)

Symbol	Parameter	Test Conditions		Min.	Typ.	Max.	Units
		V _{IN}	Conditions				
V _{OUT}	Output Voltage	7V	I _{OUT} =10mA	4.75	5.0	5.25	V
I _{OUT}	Output Current	7V		20	30		mA
ΔV _{OUT}	Load Regulation	7V	1mA ≤ I _{OUT} ≤ 30mA		60	100	mV
V _D	Voltage Drop		I _{OUT} =1mA		100		mV
I _{SS}	Current Consumption	7V	No load		5	9	uA
$\frac{\Delta V_{OUT}}{\Delta V_{IN} \times V_{OUT}}$	Line Regulation		6V ≤ V _{IN} ≤ 24V I _{OUT} =1mA		0.2		%/V
V _{IN}	Input Voltage					24	V
$\frac{\Delta V_{OUT}}{\Delta T_a}$	Temperature Coefficient	7V	I _{OUT} =10mA 0°C < T _a < 70°C		±0.75		mV/°C



Basic Circuits

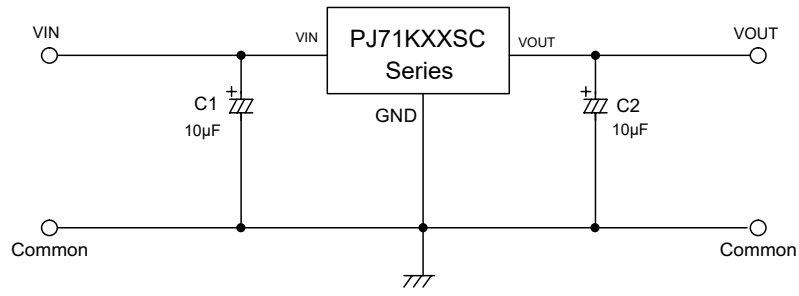



Package Outline

SOT-23-3

Dimensions in mm

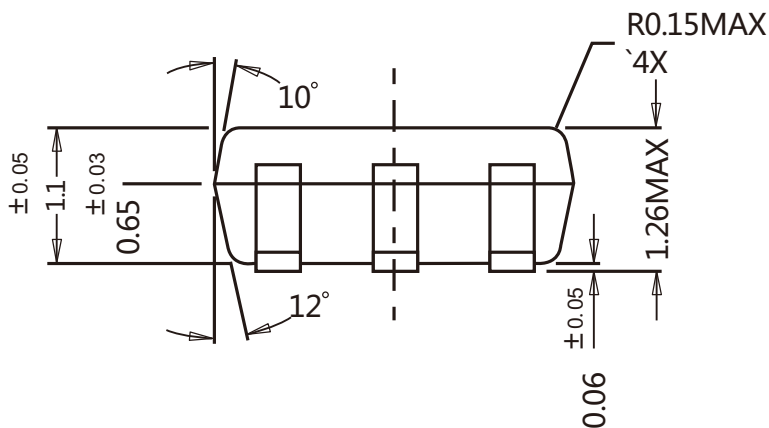
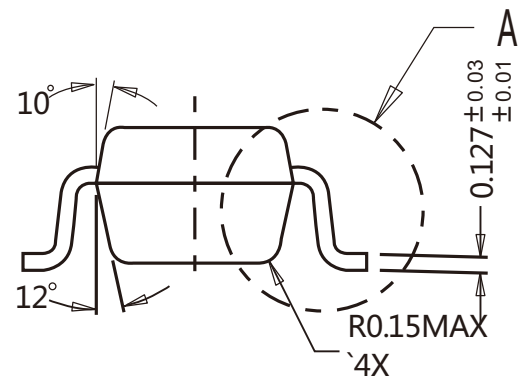
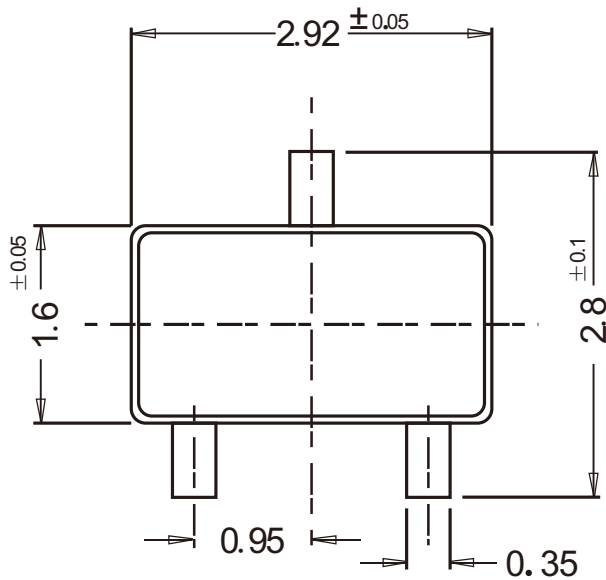

Ordering Information

Device	Package	Shipping
PJ71KXXSC Series	SOT-23-3	3000/Reel&Tape(7inch)



Conditions of Soldering and Storage

◆ Recommended condition of reflow soldering

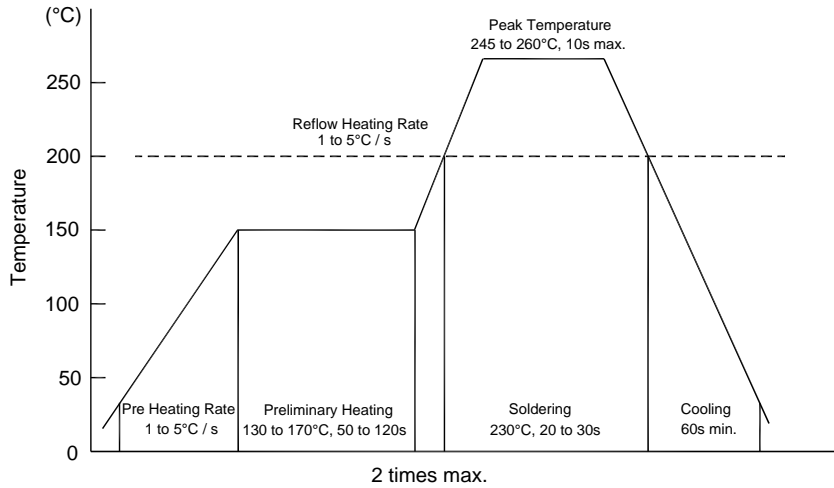

Recommended peak temperature is over 245 °C. If peak temperature is below 245 °C, you may adjust the following parameters:

- Time length of peak temperature (longer)
- Time length of soldering (longer)
- Thickness of solder paste (thicker)

◆ Conditions of hand soldering

- Temperature: 370 °C
- Time: 3s max.
- Times: one time

◆ Storage conditions

- **Temperature**
5 to 40 °C
- **Humidity**
30 to 80% RH
- **Recommended period**
One year after manufacturing



Package Specifications

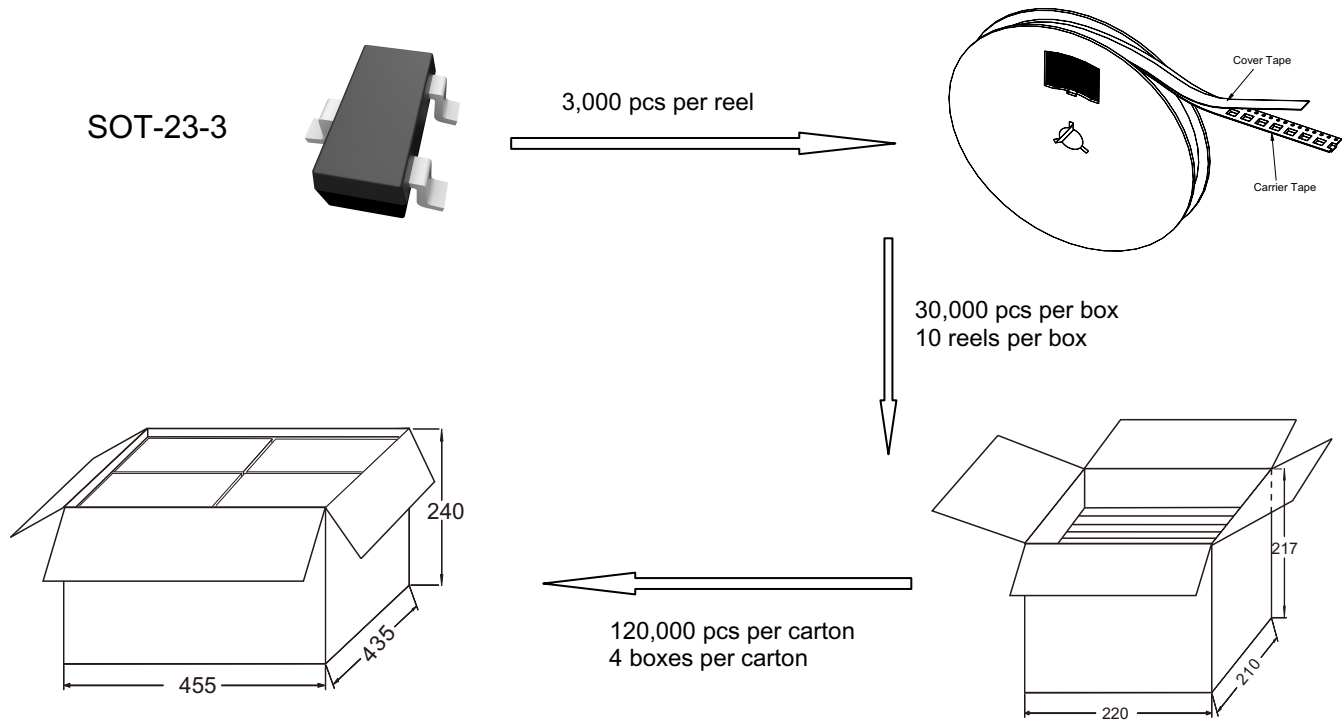

2. Tape and reel data(7inch Units:mm)

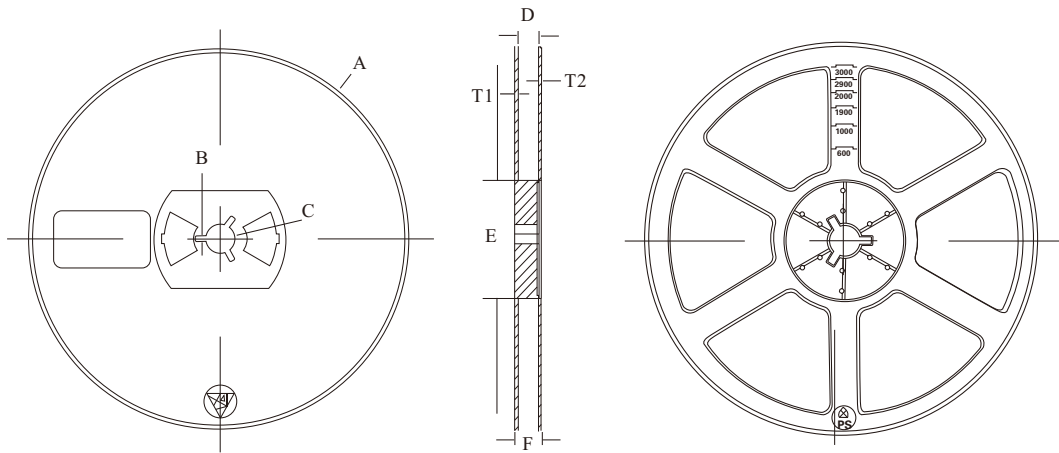

Reel (7")

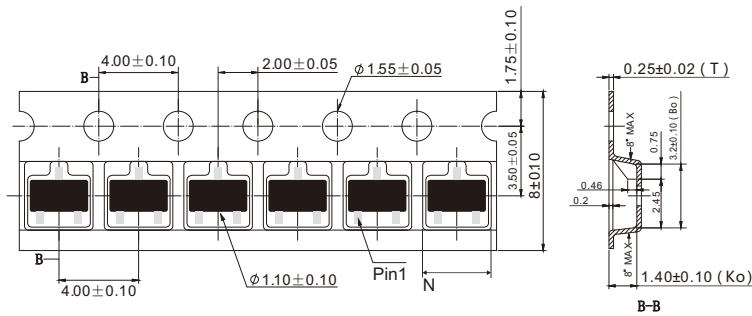

Tape (8mm)

Symbol	Value (unit: mm)
A	$\phi 177.8 \pm 1$
B	2.7 ± 0.2
C	$\phi 13.5 \pm 0.2$
E	$\phi 54.5 \pm 0.2$
F	12.3 ± 0.3
D	$9.6 \pm 2 / -0.3$
T1	1.0 ± 0.2
T2	1.2 ± 0.2
N	3.15 ± 0.1
G	1.22 ± 0.1

X-ON Electronics

Largest Supplier of Electrical and Electronic Components

Click to view similar products for [LDO Voltage Regulators](#) category:

Click to view products by [Pingjingsemi](#) manufacturer:

Other Similar products are found below :

[M38D29FFHP#U1](#) [702103A](#) [717726C](#) [742457H](#) [MP20051DN-LF-Z](#) [R5F111PGGFB#30](#) [AP7363-SP-13](#) [NCP103AMX285TCG](#)
[NCV8664CST33T3G](#) [NCV8752AMX28TCG](#) [L9454](#) [AP7362-HA-7](#) [LX13043CLD](#) [TCR3DF185,LM\(CT](#) [TCR3DF24,LM\(CT](#)
[TCR3DF285,LM\(CT](#) [TCR3DF31,LM\(CT](#) [TCR3DF45,LM\(CT](#) [TLF4949EJ](#) [L9708](#) [L970813TR](#) [030014BB](#) [059985X](#) [EAN61387601](#)
[EAN61573601](#) [NCP121AMX173TCG](#) [NCP4687DH15T1G](#) [NCV8703MX30TCG](#) [701326R](#) [702087BB](#) [755078E](#) [TCR2EN28,LF\(S](#)
[LM1117DT-1.8/NO](#) [LT1086CM#TRPBF](#) [AZ1085S2-1.5TRE1](#) [MAX15101EWL+T](#) [NCV8170AXV250T2G](#) [SCD337BTG](#)
[TCR3DF27,LM\(CT](#) [TCR3DF19,LM\(CT](#) [TCR3DF125,LM\(CT](#) [TCR2EN18,LF\(S](#) [MAX15103EWL+T](#) [TS2937CZ-5.0 C0](#) [MAX8878EUK30-](#)
[T](#) [MAX663CPA](#) [NCV4269CPD50R2G](#) [NCV8716MT30TBG](#) [AZ1117IH-1.2TRG1](#) [MP2013GQ-P](#)