



PJ73ALXXSC Series Low Dropout Regulators

Description

The PJ73ALXXSC series is a set of three-terminal low power high voltage regulators implemented in CMOS technology. They allow input voltages as high as 20V. They are available with several fixed output voltages ranging from 2.1V to 9.0V. Because of the low power dissipation, PJ73ALXXSC series are widely used in a variety of equipment such as audio device, video device, communication device and so on.

Features

- ◆ Low power consumption
- ◆ Low voltage drop
- ◆ Low temperature coefficient
- ◆ High input voltage (up to 20V)
- ◆ Quiescent current : 1.5 μ A
- ◆ Output voltage tolerance: \pm 2%
- ◆ HAF(halogen and antimony free) is acquired

Selection Table

Designator	Symbol	Description
XX	21	2.1V(output)
	23	2.3V
	25	2.5V
	28	2.8V
	30	3.0V
	33	3.3V
	36	3.6V
	40	4.0V
	44	4.4V
	50	5.0V
	90	9.0V

SOT-23-3

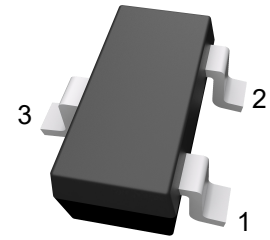

1.GND 2.VOUT 3.VIN

Block Diagram

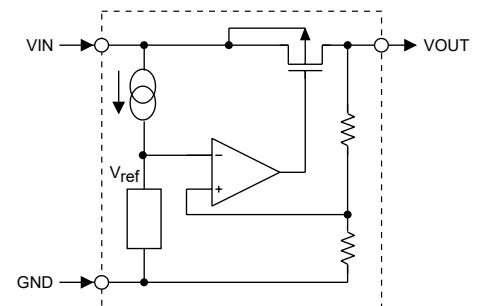



PJ73ALXXSC Series Low Dropout Regulators

Absolute Maximum Ratings ^{Note1}

Ratings at 25°C ambient temperature unless otherwise specified.

Parameter	Limit	Unit
Supply voltage	-0.3 ~ +22	V
Storage temperature range	-50 ~ +125	°C
Operating temperature range	-40 ~ 85	°C

Note: 1. Stresses beyond those listed under absolute maximum ratings may cause permanent damage to the device. These are stress ratings only, and functional operation of the device at these or any other conditions beyond those conditions is not implied. Exposure to absolute-maximum-rated conditions for extended periods may affect device reliability.

Parameter	Symbol	Value	Unit
Junction-to-Ambient Thermal Resistance	$R_{\theta JA}$	286	°C/W
Power Consumption	P_D	350	mW

Electrical Characteristics

PJ73AL21SC($T_A=25^\circ\text{C}$)

Parameter	Symbol	Test conditions	Min.	Typ.	Max	Unit
Output voltage	V_{OUT}	$V_{IN}=V_{OUT}+2.0V$, $I_{OUT}=10\text{mA}$	2.058	2.10	2.142	V
Output current	I_{OUT}	$V_{IN}=V_{OUT}+2.0V$	300	--	--	mA
Load regulation	ΔV_{OUT}	$V_{IN}=V_{OUT}+2.0V$ $1\text{mA}\leq I_{OUT}\leq 300\text{mA}$	--	37	100	mV
Voltage drop ^{Note2}	V_{DIF}	$I_{OUT}=10\text{mA}$, $\Delta V_{OUT}=2\%$	--	45	55	mV
Quiescent Current	I_Q	No Load	--	1.5	3.0	μA
Line regulation	$\frac{\Delta V_{OUT}}{V_{OUT}} \times \Delta V_{IN}$	$V_{OUT}+1.0V\leq V_{IN}\leq 20V$, $I_{OUT}=1\text{mA}$	--	--	0.2	%/V
Input voltage	V_{IN}	--	--	--	20	V
Temperature coefficient	$\frac{\Delta V_{OUT}}{V_{OUT}} \times \Delta T_A$	$V_{IN}=V_{OUT}+2.0V$, $I_{OUT}=10\text{mA}$, $-40^\circ\text{C}\leq T_A\leq 85^\circ\text{C}$	--	100	--	ppm/°C
Short Current	I_{Short}	$V_{OUT}=0V$	--	400	--	mA



PJ73ALXXSC Series

Low Dropout Regulators

PJ73AL23SC($T_A=25^\circ\text{C}$)

Parameter	Symbol	Test conditions	Min.	Typ.	Max	Unit
Output voltage	V_{OUT}	$V_{IN}=V_{OUT}+2.0V$, $I_{OUT}=10\text{mA}$	2.254	2.30	2.346	V
Output current	I_{OUT}	$V_{IN}=V_{OUT}+2.0V$	300	--	--	mA
Load regulation	ΔV_{OUT}	$V_{IN}=V_{OUT}+2.0V$ $1\text{mA}\leq I_{OUT}\leq 300\text{mA}$	--	37	100	mV
Voltage drop ^{Note2}	V_{DIF}	$I_{OUT}=10\text{mA}$, $\Delta V_{OUT}=2\%$	--	40	55	mV
Quiescent Current	I_Q	No Load	--	1.5	3.0	μA
Line regulation	$\frac{\Delta V_{OUT}}{V_{OUT}} \times \Delta V_{IN}$	$V_{OUT}+1.0V\leq V_{IN}\leq 20V$, $I_{OUT}=1\text{mA}$	--	--	0.2	%/V
Input voltage	V_{IN}	--	--	--	20	V
Temperature coefficient	$\frac{\Delta V_{OUT}}{V_{OUT}} \times \Delta T_A$	$V_{IN}=V_{OUT}+2.0V$, $I_{OUT}=10\text{mA}$, $-40^\circ\text{C}\leq T_A\leq 85^\circ\text{C}$	--	100	--	ppm/ $^\circ\text{C}$
Short Current	I_{Short}	$V_{OUT}=0V$	--	400	--	mA

PJ73AL25SC($T_A=25^\circ\text{C}$)

Parameter	Symbol	Test conditions	Min.	Typ.	Max	Unit
Output voltage	V_{OUT}	$V_{IN}=V_{OUT}+2.0V$, $I_{OUT}=10\text{mA}$	2.45	2.50	2.55	V
Output current	I_{OUT}	$V_{IN}=V_{OUT}+2.0V$	300	--	--	mA
Load regulation	ΔV_{OUT}	$V_{IN}=V_{OUT}+2.0V$ $1\text{mA}\leq I_{OUT}\leq 300\text{mA}$	--	37	100	mV
Voltage drop ^{Note2}	V_{DIF}	$I_{OUT}=10\text{mA}$, $\Delta V_{OUT}=2\%$	--	35	55	mV
Quiescent Current	I_Q	No Load	--	1.5	3.0	μA
Line regulation	$\frac{\Delta V_{OUT}}{V_{OUT}} \times \Delta V_{IN}$	$V_{OUT}+1.0V\leq V_{IN}\leq 20V$, $I_{OUT}=1\text{mA}$	--	--	0.2	%/V
Input voltage	V_{IN}	--	--	--	20	V
Temperature coefficient	$\frac{\Delta V_{OUT}}{V_{OUT}} \times \Delta T_A$	$V_{IN}=V_{OUT}+2.0V$, $I_{OUT}=10\text{mA}$, $-40^\circ\text{C}\leq T_A\leq 85^\circ\text{C}$	--	100	--	ppm/ $^\circ\text{C}$
Short Current	I_{Short}	$V_{OUT}=0V$	--	400	--	mA



PJ73ALXXSC Series

Low Dropout Regulators

PJ73AL28SC(T_A=25°C)

Parameter	Symbol	Test conditions	Min.	Typ.	Max	Unit
Output voltage	V _{OUT}	V _{IN} =V _{OUT} +2.0V, I _{OUT} =10mA	2.744	2.80	2.856	V
Output current	I _{OUT}	V _{IN} =V _{OUT} +2.0V	300	--	--	mA
Load regulation	ΔV _{OUT}	V _{IN} =V _{OUT} +2.0V 1mA≤I _{OUT} ≤300mA	--	37	100	mV
Voltage drop ^{Note2}	V _{DIF}	I _{OUT} =10mA, ΔV _{OUT} =2%	--	30	55	mV
Quiescent Current	I _Q	No Load	--	1.5	3.0	μA
Line regulation	$\frac{\Delta V_{OUT}}{V_{OUT}} \times \Delta V_{IN}$	V _{OUT} +1.0V≤V _{IN} ≤20V, I _{OUT} =1mA	--	--	0.2	%/V
Input voltage	V _{IN}	--	--	--	20	V
Temperature coefficient	$\frac{\Delta V_{OUT}}{V_{OUT}} \times \Delta T_A$	V _{IN} =V _{OUT} +2.0V, I _{OUT} =10mA, -40°C≤T _A ≤85°C	--	100	--	ppm/°C
Short Current	I _{Short}	V _{OUT} =0V	--	400	--	mA

PJ73AL30SC(T_A=25°C)

Parameter	Symbol	Test conditions	Min.	Typ.	Max	Unit
Output voltage	V _{OUT}	V _{IN} =V _{OUT} +2.0V, I _{OUT} =10mA	2.94	3.0	3.06	V
Output current	I _{OUT}	V _{IN} =V _{OUT} +2.0V	300	--	--	mA
Load regulation	ΔV _{OUT}	V _{IN} =V _{OUT} +2.0V 1mA≤I _{OUT} ≤300mA	--	37	100	mV
Voltage drop ^{Note2}	V _{DIF}	I _{OUT} =100mA, ΔV _{OUT} =2%	--	210	300	mV
Quiescent Current	I _Q	No Load	--	1.5	3.0	μA
Line regulation	$\frac{\Delta V_{OUT}}{V_{OUT}} \times \Delta V_{IN}$	V _{OUT} +1.0V≤V _{IN} ≤20V, I _{OUT} =1mA	--	--	0.2	%/V
Input voltage	V _{IN}	--	--	--	20	V
Temperature coefficient	$\frac{\Delta V_{OUT}}{V_{OUT}} \times \Delta T_A$	V _{IN} =V _{OUT} +2.0V, I _{OUT} =10mA, -40°C≤T _A ≤85°C	--	100	--	ppm/°C
Short Current	I _{Short}	V _{OUT} =0V	--	400	--	mA



PJ73ALXXSC Series

Low Dropout Regulators

PJ73AL33SC($T_A=25^\circ\text{C}$)

Parameter	Symbol	Test conditions	Min.	Typ.	Max	Unit
Output voltage	V_{OUT}	$V_{IN}=V_{OUT}+2.0\text{V}$, $I_{OUT}=10\text{mA}$	3.234	3.30	3.366	V
Output current	I_{OUT}	$V_{IN}=V_{OUT}+2.0\text{V}$	300	--	--	mA
Load regulation	ΔV_{OUT}	$V_{IN}=V_{OUT}+2.0\text{V}$ $1\text{mA}\leq I_{OUT}\leq 300\text{mA}$	--	37	100	mV
Voltage drop ^{Note2}	V_{DIF}	$I_{OUT}=100\text{mA}$, $\Delta V_{OUT}=2\%$	--	195	300	mV
Quiescent Current	I_Q	No Load	--	1.5	3.0	μA
Line regulation	$\frac{\Delta V_{OUT}}{V_{OUT}} \times \Delta V_{IN}$	$V_{OUT}+1.0\text{V}\leq V_{IN}\leq 20\text{V}$, $I_{OUT}=1\text{mA}$	--	--	0.2	%/V
Input voltage	V_{IN}	--	--	--	20	V
Temperature coefficient	$\frac{\Delta V_{OUT}}{V_{OUT}} \times \Delta T_A$	$V_{IN}=V_{OUT}+2.0\text{V}$, $I_{OUT}=10\text{mA}$, $-40^\circ\text{C}\leq T_A\leq 85^\circ\text{C}$	--	100	--	ppm/ $^\circ\text{C}$
Short Current	I_{Short}	$V_{OUT}=0\text{V}$	--	400	--	mA

PJ73AL36SC($T_A=25^\circ\text{C}$)

Parameter	Symbol	Test conditions	Min.	Typ.	Max	Unit
Output voltage	V_{OUT}	$V_{IN}=V_{OUT}+2.0\text{V}$, $I_{OUT}=10\text{mA}$	3.528	3.60	3.672	V
Output current	I_{OUT}	$V_{IN}=V_{OUT}+2.0\text{V}$	300	--	--	mA
Load regulation	ΔV_{OUT}	$V_{IN}=V_{OUT}+2.0\text{V}$ $1\text{mA}\leq I_{OUT}\leq 300\text{mA}$	--	37	100	mV
Voltage drop ^{Note2}	V_{DIF}	$I_{OUT}=100\text{mA}$, $\Delta V_{OUT}=2\%$	--	180	300	mV
Quiescent Current	I_Q	No Load	--	1.5	3.0	μA
Line regulation	$\frac{\Delta V_{OUT}}{V_{OUT}} \times \Delta V_{IN}$	$V_{OUT}+1.0\text{V}\leq V_{IN}\leq 20\text{V}$, $I_{OUT}=1\text{mA}$	--	--	0.2	%/V
Input voltage	V_{IN}	--	--	--	20	V
Temperature coefficient	$\frac{\Delta V_{OUT}}{V_{OUT}} \times \Delta T_A$	$V_{IN}=V_{OUT}+2.0\text{V}$, $I_{OUT}=10\text{mA}$, $-40^\circ\text{C}\leq T_A\leq 85^\circ\text{C}$	--	100	--	ppm/ $^\circ\text{C}$
Short Current	I_{Short}	$V_{OUT}=0\text{V}$	--	400	--	mA



PJ73AL40SC(T_A=25°C)

Parameter	Symbol	Test conditions	Min.	Typ.	Max	Unit
Output voltage	V _{OUT}	V _{IN} =V _{OUT} +2.0V, I _{OUT} =10mA	3.92	4.0	4.08	V
Output current	I _{OUT}	V _{IN} =V _{OUT} +2.0V	300	--	--	mA
Load regulation	ΔV _{OUT}	V _{IN} =V _{OUT} +2.0V 1mA≤I _{OUT} ≤300mA	--	37	100	mV
Voltage drop ^{Note2}	V _{DIF}	I _{OUT} =100mA, ΔV _{OUT} =2%	--	170	300	mV
Quiescent Current	I _Q	No Load	--	1.5	3.0	μA
Line regulation	$\frac{\Delta V_{OUT}}{V_{OUT}} \times \Delta V_{IN}$	V _{OUT} +1.0V≤V _{IN} ≤20V, I _{OUT} =1mA	--	--	0.2	%/V
Input voltage	V _{IN}	--	--	--	20	V
Temperature coefficient	$\frac{\Delta V_{OUT}}{V_{OUT}} \times \Delta T_A$	V _{IN} =V _{OUT} +2.0V, I _{OUT} =10mA, -40°C≤T _A ≤85°C	--	100	--	ppm/°C
Short Current	I _{Short}	V _{OUT} =0V	--	400	--	mA

PJ73AL44SC(T_A=25°C)

Parameter	Symbol	Test conditions	Min.	Typ.	Max	Unit
Output voltage	V _{OUT}	V _{IN} =V _{OUT} +2.0V, I _{OUT} =10mA	4.312	4.4	4.488	V
Output current	I _{OUT}	V _{IN} =V _{OUT} +2.0V	300	--	--	mA
Load regulation	ΔV _{OUT}	V _{IN} =V _{OUT} +2.0V 1mA≤I _{OUT} ≤300mA	--	37	100	mV
Voltage drop ^{Note2}	V _{DIF}	I _{OUT} =100mA, ΔV _{OUT} =2%	--	160	300	mV
Quiescent Current	I _Q	No Load	--	1.5	3.0	μA
Line regulation	$\frac{\Delta V_{OUT}}{V_{OUT}} \times \Delta V_{IN}$	V _{OUT} +1.0V≤V _{IN} ≤20V, I _{OUT} =1mA	--	--	0.2	%/V
Input voltage	V _{IN}	--	--	--	20	V
Temperature coefficient	$\frac{\Delta V_{OUT}}{V_{OUT}} \times \Delta T_A$	V _{IN} =V _{OUT} +2.0V, I _{OUT} =10mA, -40°C≤T _A ≤85°C	--	100	--	ppm/°C
Short Current	I _{Short}	V _{OUT} =0V	--	400	--	mA



PJ73AL50SC($T_A=25^\circ\text{C}$)

Parameter	Symbol	Test conditions	Min.	Typ.	Max	Unit
Output voltage	V_{OUT}	$V_{IN}=V_{OUT}+2.0V$, $I_{OUT}=10\text{mA}$	4.90	5.0	5.10	V
Output current	I_{OUT}	$V_{IN}=V_{OUT}+2.0V$	300	--	--	mA
Load regulation	ΔV_{OUT}	$V_{IN}=V_{OUT}+2.0V$ $1\text{mA}\leq I_{OUT}\leq 300\text{mA}$	--	37	100	mV
Voltage drop ^{Note2}	V_{DIF}	$I_{OUT}=100\text{mA}$, $\Delta V_{OUT}=2\%$	--	150	300	mV
Quiescent Current	I_Q	No Load	--	1.5	3.0	μA
Line regulation	$\frac{\Delta V_{OUT}}{V_{OUT}} \times \Delta V_{IN}$	$V_{OUT}+1.0V \leq V_{IN} \leq 20V$, $I_{OUT}=1\text{mA}$	--	--	0.2	%/V
Input voltage	V_{IN}	--	--	--	20	V
Temperature coefficient	$\frac{\Delta V_{OUT}}{V_{OUT}} \times \Delta T_A$	$V_{IN}=V_{OUT}+2.0V$, $I_{OUT}=10\text{mA}$, $-40^\circ\text{C} \leq T_A \leq 85^\circ\text{C}$	--	100	--	ppm/ $^\circ\text{C}$
Short Current	I_{Short}	$V_{OUT}=0V$	--	400	--	mA

PJ73AL90SC($T_A=25^\circ\text{C}$)

Parameter	Symbol	Test conditions	Min.	Typ.	Max	Unit
Output voltage	V_{OUT}	$V_{IN}=V_{OUT}+2.0V$, $I_{OUT}=10\text{mA}$	8.82	9.0	9.18	V
Output current	I_{OUT}	$V_{IN}=V_{OUT}+2.0V$	300	--	--	mA
Load regulation	ΔV_{OUT}	$V_{IN}=V_{OUT}+2.0V$ $1\text{mA}\leq I_{OUT}\leq 300\text{mA}$	--	37	100	mV
Voltage drop ^{Note2}	V_{DIF}	$I_{OUT}=100\text{mA}$, $\Delta V_{OUT}=2\%$	--	130	300	mV
Quiescent Current	I_Q	No Load	--	1.5	3.0	μA
Line regulation	$\frac{\Delta V_{OUT}}{V_{OUT}} \times \Delta V_{IN}$	$V_{OUT}+1.0V \leq V_{IN} \leq 20V$, $I_{OUT}=1\text{mA}$	--	--	0.2	%/V
Input voltage	V_{IN}	--	--	--	20	V
Temperature coefficient	$\frac{\Delta V_{OUT}}{V_{OUT}} \times \Delta T_A$	$V_{IN}=V_{OUT}+2.0V$, $I_{OUT}=10\text{mA}$, $-40^\circ\text{C} \leq T_A \leq 85^\circ\text{C}$	--	100	--	ppm/ $^\circ\text{C}$
Short Current	I_{Short}	$V_{OUT}=0V$	--	400	--	mA

Note: 2.The difference of input voltage and output voltage when input voltage falls down gradually till output voltage equals to 98% of rating V_{OUT} .



Basic Circuits

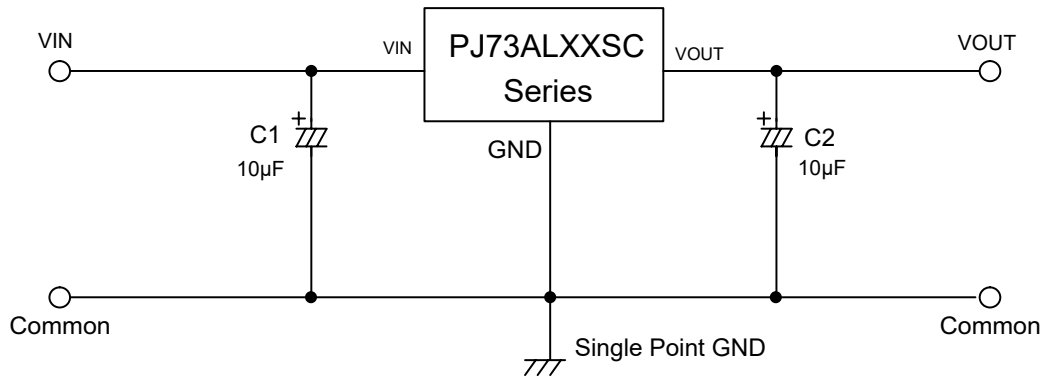



Package Outline

SOT-23-3

Dimensions in mm

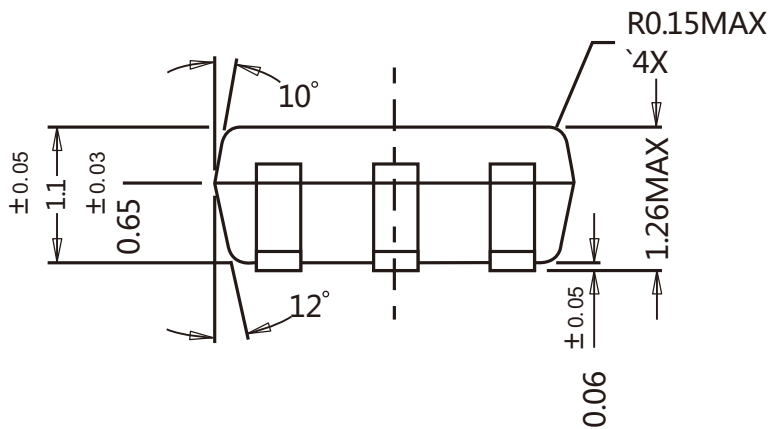
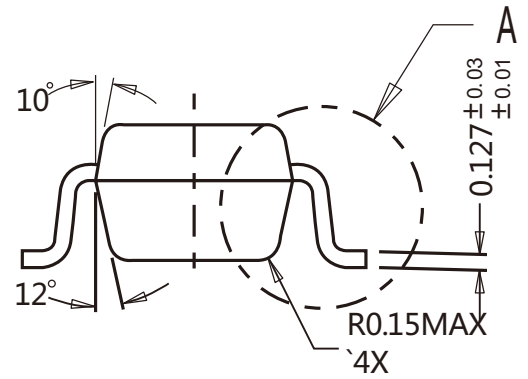
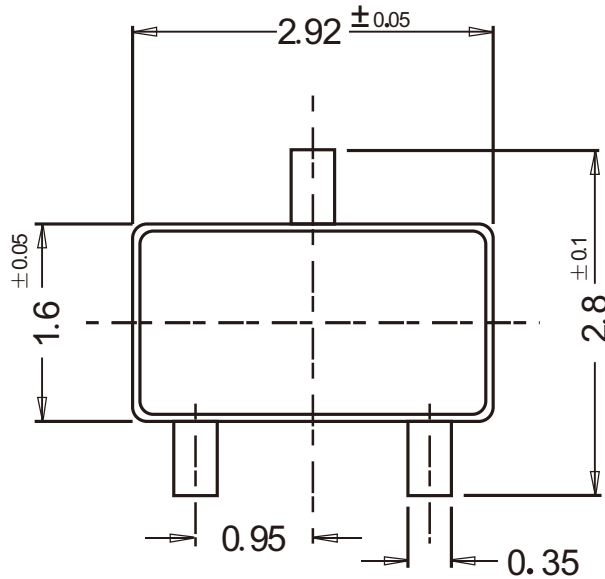

Ordering Information

Device	Package	Shipping
PJ73ALXXSC	SOT-23-3	3000PCS/Reel&Tape



Conditions of Soldering

◆ Recommended condition of reflow soldering

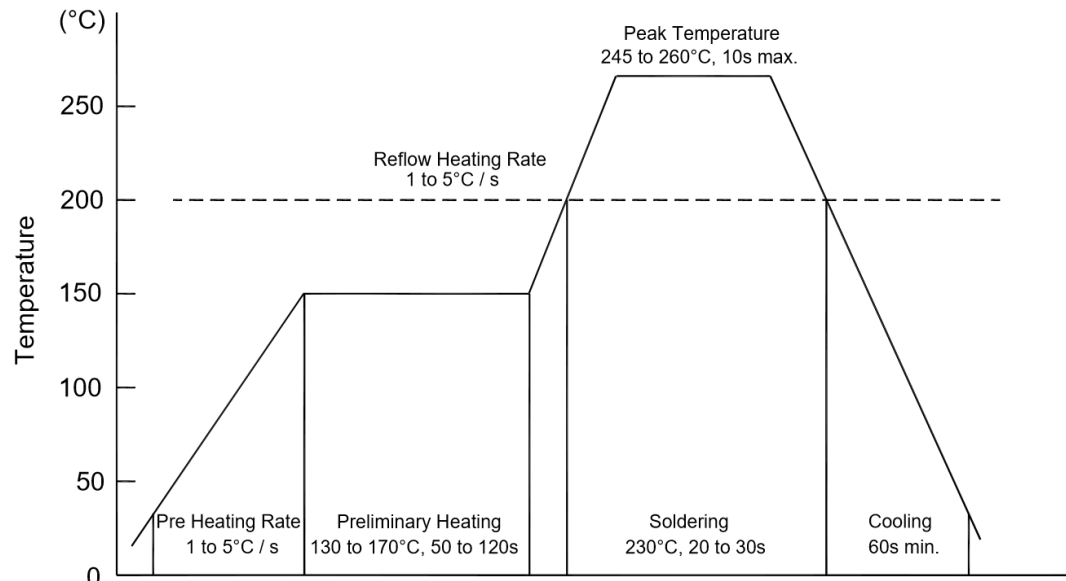

Recommended peak temperature is over 245 °C. If peak temperature is below 245 °C, you may adjust the following parameters:

- Time length of peak temperature (longer)
- Time length of soldering (longer)
- Thickness of solder paste (thicker)

◆ Conditions of hand soldering

- Temperature: 370 °C
- Time: 3s max.
- Times: one time

◆ Storage conditions

- **Temperature**
5 to 40 °C
- **Humidity**
30 to 80% RH
- **Recommended period**
One year after manufacturing



PJ73ALXXSC Series Low Dropout Regulators

Package Specifications

SOT-23-3



3,000 pcs per reel

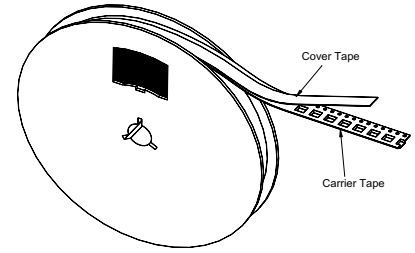
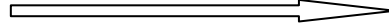

24,000 pcs per box
8 reels per box

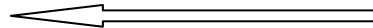
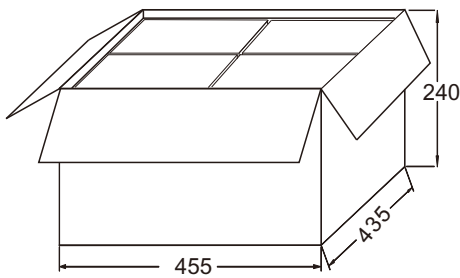
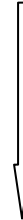

120,000 pcs per carton
5 boxes per carton

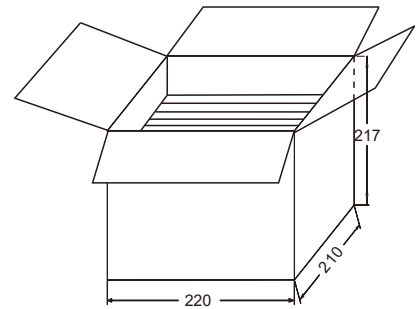

2. Tape and reel data(7inch Units:mm)

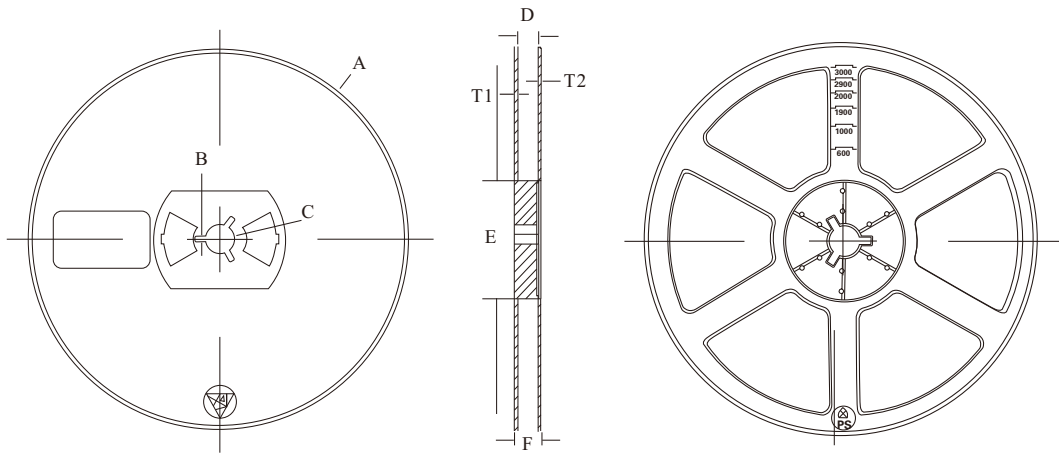

Reel (7")

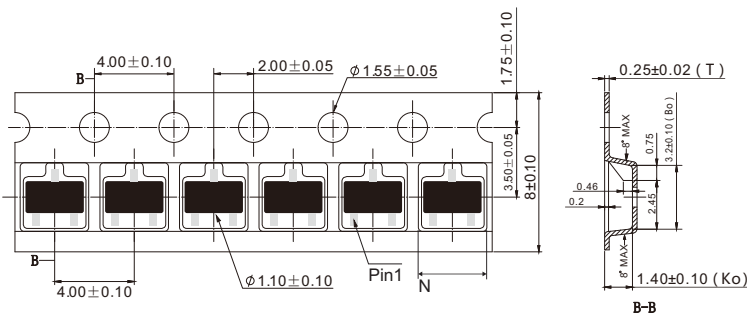

Tape (8mm)

Symbol	Value (unit: mm)
A	Ø 177.8±1
B	2.7±0.2
C	Ø 13.5±0.2
E	Ø 54.5±0.2
F	12.3±0.3
D	9.6+2/-0.3
T1	1.0±0.2
T2	1.2±0.2
N	3.15±0.1
G	1.22±0.1

X-ON Electronics

Largest Supplier of Electrical and Electronic Components

Click to view similar products for [LDO Voltage Regulators](#) category:

Click to view products by [Pingjingsemi](#) manufacturer:

Other Similar products are found below :

[M38D29FFHP#U1](#) [702103A](#) [717726C](#) [742457H](#) [MP20051DN-LF-Z](#) [R5F111PGGFB#30](#) [AP7363-SP-13](#) [NCP103AMX285TCG](#)
[NCV8664CST33T3G](#) [NCV8752AMX28TCG](#) [L9454](#) [AP7362-HA-7](#) [LX13043CLD](#) [TCR3DF185,LM\(CT](#) [TCR3DF24,LM\(CT](#)
[TCR3DF285,LM\(CT](#) [TCR3DF31,LM\(CT](#) [TCR3DF45,LM\(CT](#) [TLF4949EJ](#) [L9708](#) [L970813TR](#) [030014BB](#) [059985X](#) [EAN61387601](#)
[EAN61573601](#) [NCP121AMX173TCG](#) [NCP4687DH15T1G](#) [NCV8703MX30TCG](#) [701326R](#) [702087BB](#) [755078E](#) [TCR2EN28,LF\(S](#)
[LM1117DT-1.8/NO](#) [LT1086CM#TRPBF](#) [AZ1085S2-1.5TRE1](#) [MAX15101EWL+T](#) [NCV8170AXV250T2G](#) [SCD337BTG](#)
[TCR3DF27,LM\(CT](#) [TCR3DF19,LM\(CT](#) [TCR3DF125,LM\(CT](#) [TCR2EN18,LF\(S](#) [MAX15103EWL+T](#) [TS2937CZ-5.0 C0](#) [MAX8878EUK30-](#)
[T](#) [MAX663CPA](#) [NCV4269CPD50R2G](#) [NCV8716MT30TBG](#) [AZ1117IH-1.2TRG1](#) [MP2013GQ-P](#)