



PJ75ALXXSQ Series Low Dropout Regulators

Description

The PJ75ALXXSQ series is a set of three-terminal low power high voltage regulators implemented in CMOS technology. They allow input voltages as high as 36V. They are available with several fixed output voltages ranging from 2.8V to 5.0V. Because of the low power dissipation, PJ75ALXXSQ are widely used in a variety of equipment such as audio device, video device, communication device and so on.

Features

- ◆ Low power consumption
- ◆ Low voltage drop
- ◆ Low temperature coefficient
- ◆ High input voltage (up to 36V)
- ◆ Quiescent current : 2.5 μ A
- ◆ Output voltage tolerance: \pm 2%
- ◆ HAF(halogen and antimony free) is acquired

SOT-89

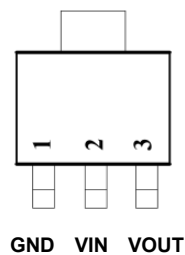
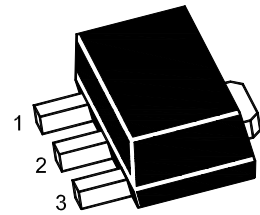

Pin assignment

Selection Tablet PJ75ALXXSQ

Designator	Symbol	Description
XX	28	2.8V(output)
	30	3.0V
	33	3.3V
	36	3.6V
	40	4.0V
	44	4.4V
	50	5.0V



PJ75ALXXSQ Series Low Dropout Regulators

Absolute Maximum Ratings^(NOTE1)

Ratings at 25°C ambient temperature unless otherwise specified.

Parameter	Limit	Unit
Supply voltage	-0.3 ~ +36	V
Storage temperature range	-50 ~ +125	°C
Operating temperature range	-40 ~ +85	°C

NOTE: 1. Stresses beyond those listed under absolute maximum ratings may cause permanent damage to the device. These are stress ratings only, and functional operation of the device at these or any other conditions beyond those conditions is not implied. Exposure to absolute-maximum-rated conditions for extended periods may affect device reliability.

Parameter	Symbol	Value	Unit
Junction-to-Ambient Thermal Resistance	$R_{\theta JA}$	200	°C/W
Power Consumption	P_D	500	mW

Electrical Characteristics

PJ75AL28SQ($T_A=25^\circ\text{C}$)

Parameter	Symbol	Test conditions	Min.	Typ.	Max	Unit
Output voltage	V_{OUT}	$V_{IN}=V_{OUT}+2.0V$, $I_{OUT}=10\text{mA}$	2.744	2.80	2.856	V
Output current	I_{OUT}	$V_{IN}=V_{OUT}+2.0V$	70	100	—	mA
Load regulation	ΔV_{OUT}	$V_{IN}=V_{OUT}+2.0V$ $1\text{mA}\leq I_{OUT}\leq 50\text{mA}$	—	25	60	mV
Voltage drop ^{Note1}	V_{DIF}	$I_{OUT}=1\text{mA}$, $\Delta V_{OUT}=2\%$	—	30	100	mV
Quiescent Current	I_Q	No Load	—	2.5	3.0	μA
Line regulation	$\frac{\Delta V_{OUT}}{V_{OUT}} \times \Delta V_{IN}$	$V_{OUT}+1.0V\leq V_{IN}\leq 30V$, $I_{OUT}=1\text{mA}$	—	—	0.2	%/V
Input voltage	V_{IN}	—	—	—	36	V
Temperature coefficient	$\frac{\Delta V_{OUT}}{V_{OUT}} \times \Delta T_A$	$V_{IN}=V_{OUT}+2.0V$, $I_{OUT}=10\text{mA}$, $-40^\circ\text{C}\leq T_A\leq 85^\circ\text{C}$	—	100	—	ppm/°C



PJ75ALXXSQ Series Low Dropout Regulators

PJ75AL30SQ(T_A=25°C)

Parameter	Symbol	Test conditions	Min.	Typ.	Max	Unit
Output voltage	V _{OUT}	V _{IN} =V _{OUT} +2.0V, I _{OUT} =10mA	2.940	3.00	3.060	V
Output current	I _{OUT}	V _{IN} =V _{OUT} +2.0V	70	100	—	mA
Load regulation	ΔV _{OUT}	V _{IN} =V _{OUT} +2.0V 1mA≤I _{OUT} ≤50mA	—	25	60	mV
Voltage drop ^{Note1}	V _{DIF}	I _{OUT} =1mA, ΔV _{OUT} =2%	—	30	100	mV
Quiescent Current	I _Q	No Load	—	2.5	3.0	μA
Line regulation	ΔV _{OUT} /V _{OUT} ×ΔV _{IN}	V _{OUT} +1.0V≤V _{IN} ≤30V, I _{OUT} =1mA	—	—	0.2	%/V
Input voltage	V _{IN}	—	—	—	36	V
Temperature coefficient	ΔV _{OUT} /V _{OUT} ×ΔT _A	V _{IN} =V _{OUT} +2.0V, I _{OUT} =10mA, -40°C≤T _A ≤85°C	—	100	—	ppm/°C

PJ75AL33SQ(T_A=25°C)

Parameter	Symbol	Test conditions	Min.	Typ.	Max	Unit
Output voltage	V _{OUT}	V _{IN} =V _{OUT} +2.0V, I _{OUT} =10mA	3.234	3.30	3.366	V
Output current	I _{OUT}	V _{IN} =V _{OUT} +2.0V	70	100	—	mA
Load regulation	ΔV _{OUT}	V _{IN} =V _{OUT} +2.0V 1mA≤I _{OUT} ≤50mA	—	25	60	mV
Voltage drop ^{Note1}	V _{DIF}	I _{OUT} =1mA, ΔV _{OUT} =2%	—	25	55	mV
Quiescent Current	I _Q	No Load	—	2.5	3.0	μA
Line regulation	ΔV _{OUT} /V _{OUT} ×ΔV _{IN}	V _{OUT} +1.0V≤V _{IN} ≤30V, I _{OUT} =1mA	—	—	0.2	%/V
Input voltage	V _{IN}	—	—	—	36	V
Temperature coefficient	ΔV _{OUT} /V _{OUT} ×ΔT _A	V _{IN} =V _{OUT} +2.0V, I _{OUT} =10mA, -40°C≤T _A ≤85°C	—	100	—	ppm/°C

PJ75AL36SQ(T_A=25°C)

Parameter	Symbol	Test conditions	Min.	Typ.	Max	Unit
Output voltage	V _{OUT}	V _{IN} =V _{OUT} +2.0V, I _{OUT} =10mA	3.528	3.60	3.672	V
Output current	I _{OUT}	V _{IN} =V _{OUT} +2.0V	70	100	—	mA
Load regulation	ΔV _{OUT}	V _{IN} =V _{OUT} +2.0V 1mA≤I _{OUT} ≤50mA	—	25	60	mV
Voltage drop ^{Note1}	V _{DIF}	I _{OUT} =1mA, ΔV _{OUT} =2%	—	25	55	mV
Quiescent Current	I _Q	No Load	—	2.5	3.0	μA
Line regulation	ΔV _{OUT} /V _{OUT} ×ΔV _{IN}	V _{OUT} +1.0V≤V _{IN} ≤30V, I _{OUT} =1mA	—	—	0.2	%/V
Input voltage	V _{IN}	—	—	—	36	V
Temperature coefficient	ΔV _{OUT} /V _{OUT} ×ΔT _A	V _{IN} =V _{OUT} +2.0V, I _{OUT} =10mA, -40°C≤T _A ≤85°C	—	100	—	ppm/°C



PJ75ALXXSQ Series Low Dropout Regulators

PJ75AL40SQ(T_A=25°C)

Parameter	Symbol	Test conditions	Min.	Typ.	Max	Unit
Output voltage	V _{OUT}	V _{IN} =V _{OUT} +2.0V, I _{OUT} =10mA	3.920	4.0	4.080	V
Output current	I _{OUT}	V _{IN} =V _{OUT} +2.0V	70	100	—	mA
Load regulation	ΔV _{OUT}	V _{IN} =V _{OUT} +2.0V 1mA≤I _{OUT} ≤50mA	—	25	60	mV
Voltage drop ^{Note1}	V _{DIF}	I _{OUT} =1mA, ΔV _{OUT} =2%	—	25	55	mV
Quiescent Current	I _Q	No Load	—	2.5	3.0	μA
Line regulation	ΔV _{OUT} / V _{OUT} ×ΔV _{IN}	V _{OUT} +1.0V≤V _{IN} ≤30V, I _{OUT} =1mA	—	—	0.2	%/V
Input voltage	V _{IN}	—	—	—	36	V
Temperature coefficient	ΔV _{OUT} /V _{OUT} ×ΔT _A	V _{IN} = V _{OUT} +2.0V, I _{OUT} =10mA, -40°C≤T _A ≤85°C	—	100	—	ppm/°C

PJ75AL44SQ(T_A=25°C)

Parameter	Symbol	Test conditions	Min.	Typ.	Max	Unit
Output voltage	V _{OUT}	V _{IN} =V _{OUT} +2.0V , I _{OUT} =10mA	4.312	4.4	4.488	V
Output current	I _{OUT}	V _{IN} =V _{OUT} +2.0V	70	100	—	mA
Load regulation	ΔV _{OUT}	V _{IN} =V _{OUT} +2.0V 1mA≤I _{OUT} ≤50mA	—	25	60	mV
Voltage drop ^{Note1}	V _{DIF}	I _{OUT} =1mA, ΔV _{OUT} =2%	—	25	55	mV
Quiescent Current	I _Q	No Load	—	2.5	3.0	μA
Line regulation	ΔV _{OUT} / V _{OUT} ×ΔV _{IN}	V _{OUT} +1.0V≤V _{IN} ≤30V, I _{OUT} =1mA	—	—	0.2	%/V
Input voltage	V _{IN}	—	—	—	36	V
Temperature coefficient	ΔV _{OUT} /V _{OUT} ×ΔT _A	V _{IN} = V _{OUT} +2.0V, I _{OUT} =10mA, -40°C≤T _A ≤85°C	—	100	—	ppm/°C

PJ75AL50SQ(T_A=25°C)

Parameter	Symbol	Test conditions	Min.	Typ.	Max	Unit
Output voltage	V _{OUT}	V _{IN} =V _{OUT} +2.0V , I _{OUT} =10mA	4.900	5.0	5.100	V
Output current	I _{OUT}	V _{IN} =V _{OUT} +2.0V	100	150	—	mA
Load regulation	ΔV _{OUT}	V _{IN} =V _{OUT} +2.0V 1mA≤I _{OUT} ≤70mA	—	25	60	mV
Voltage drop ^{Note1}	V _{DIF}	I _{OUT} =1mA, ΔV _{OUT} =2%	—	25	55	mV
Quiescent Current	I _Q	No Load	—	3.5	4.0	μA
Line regulation	ΔV _{OUT} / V _{OUT} ×ΔV _{IN}	V _{OUT} +1.0 V≤V _{IN} ≤30V, I _{OUT} =1mA	—	—	0.2	%/V
Input voltage	V _{IN}	—	—	—	36	V
Temperature coefficient	ΔV _{OUT} /V _{OUT} ×ΔT _A	V _{IN} = V _{OUT} +2.0V, I _{OUT} =10mA, -40°C≤T _A ≤85°C	—	100	—	ppm/°C

NOTE: 1.The difference of input voltage and output voltage when input voltage falls down gradually till output voltage equals to 98% of rating V_{OUT} .



Application Circuit

Basic circuits

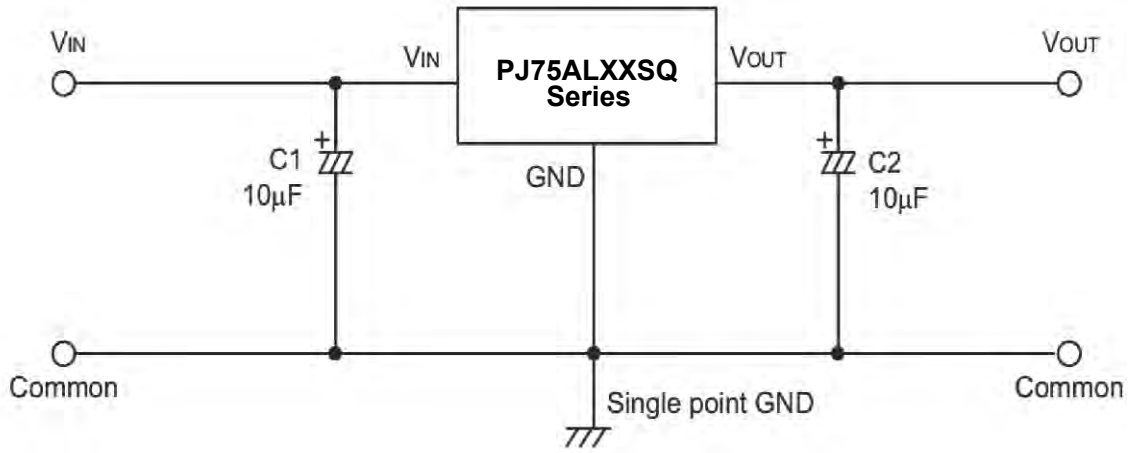



PJ75ALXXSQ Series Low Dropout Regulators

Package Outline

SOT-89

Dimensions in mm

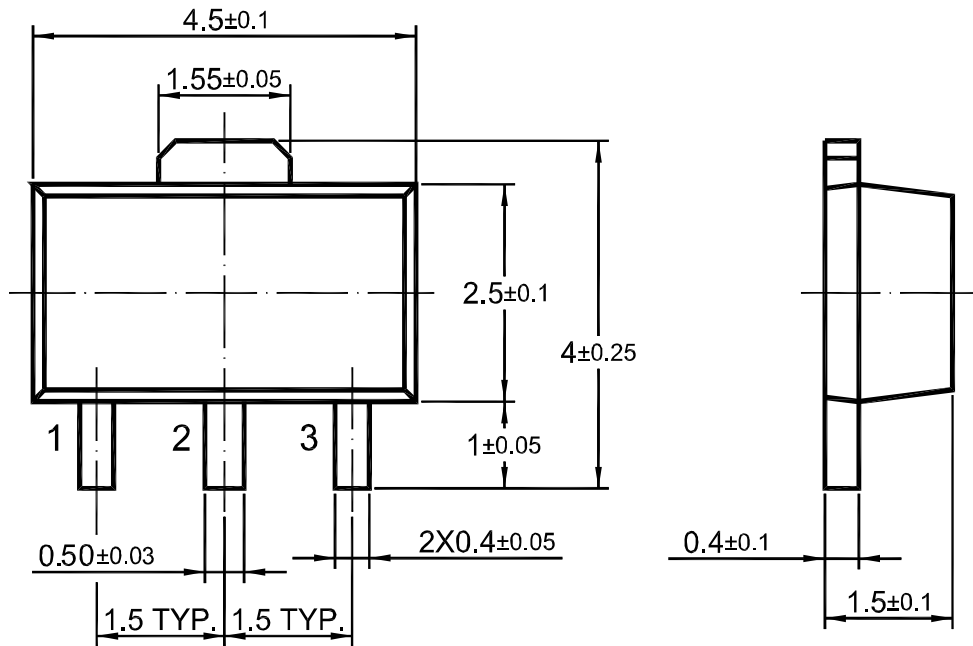

Ordering Information

Device	Package	Shipping
PJ75ALXXSQ	SOT-89	1000PCS/Reel&Tape



Conditions of Soldering

◆ Recommended condition of reflow soldering

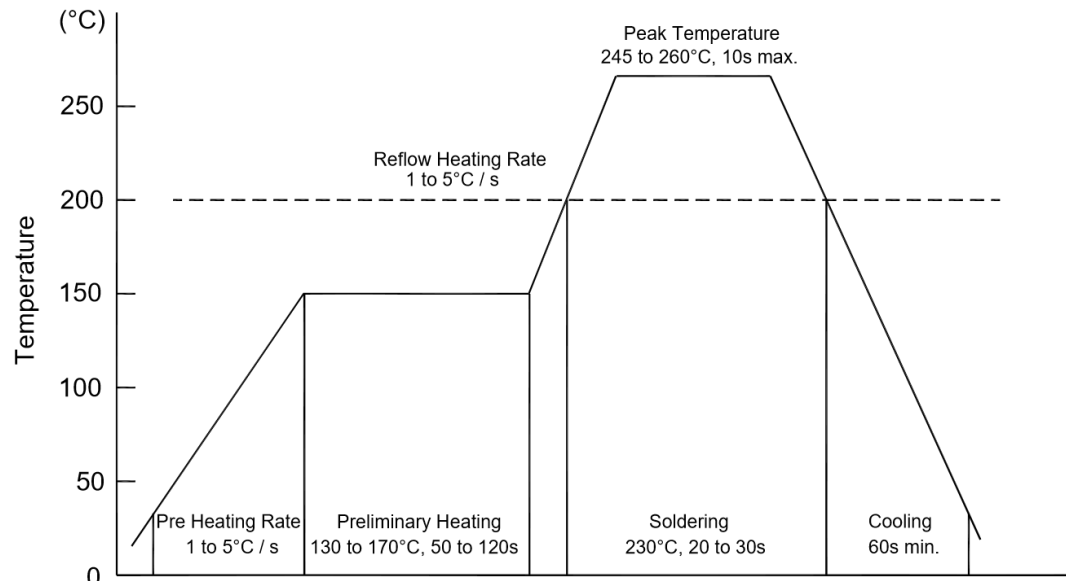

Recommended peak temperature is over 245 °C. If peak temperature is below 245 °C, you may adjust the following parameters:

- Time length of peak temperature (longer)
- Time length of soldering (longer)
- Thickness of solder paste (thicker)

◆ Conditions of hand soldering

- Temperature: 370 °C
- Time: 3s max.
- Times: one time

◆ Storage conditions

- **Temperature**
5 to 40 °C
- **Humidity**
30 to 80% RH
- **Recommended period**
One year after manufacturing



PJ75ALXXSQ Series Low Dropout Regulators

Package Specification

The method of packaging and dimension are shown as below figure.

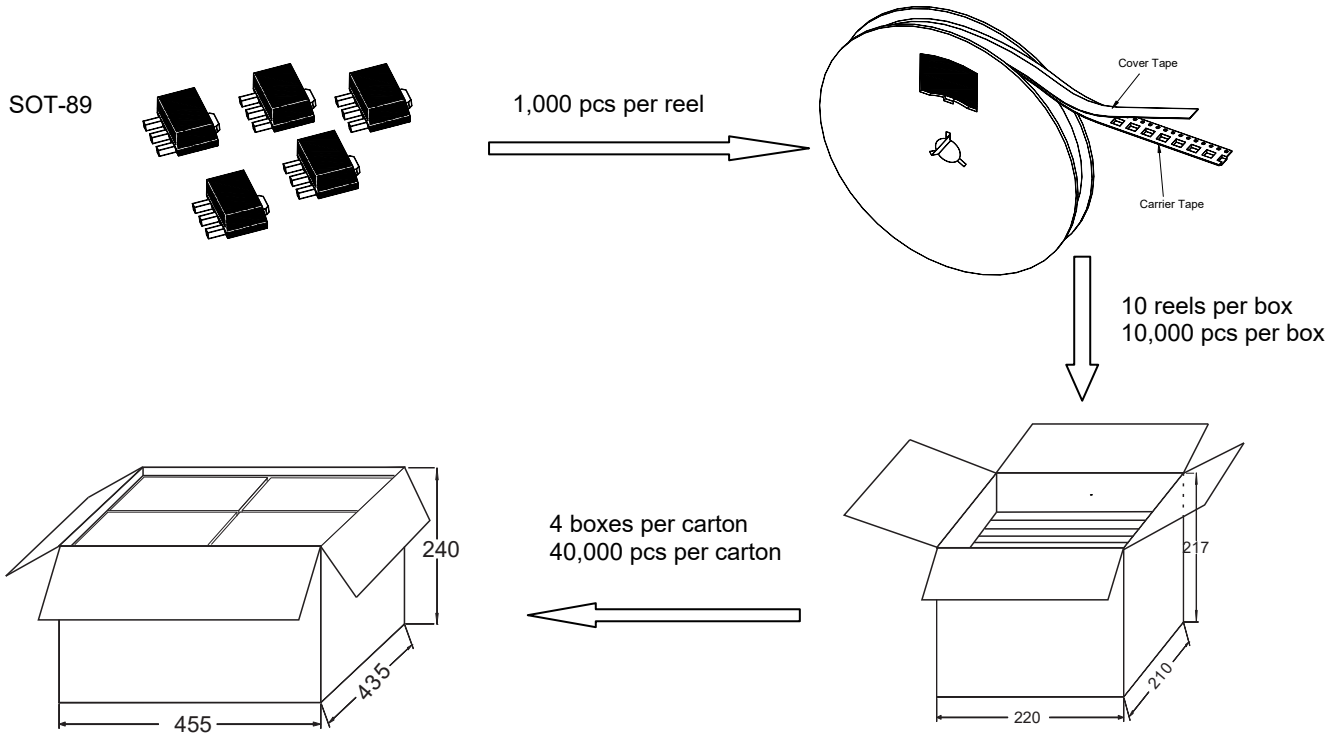

Tape and reel data (Units: mm)

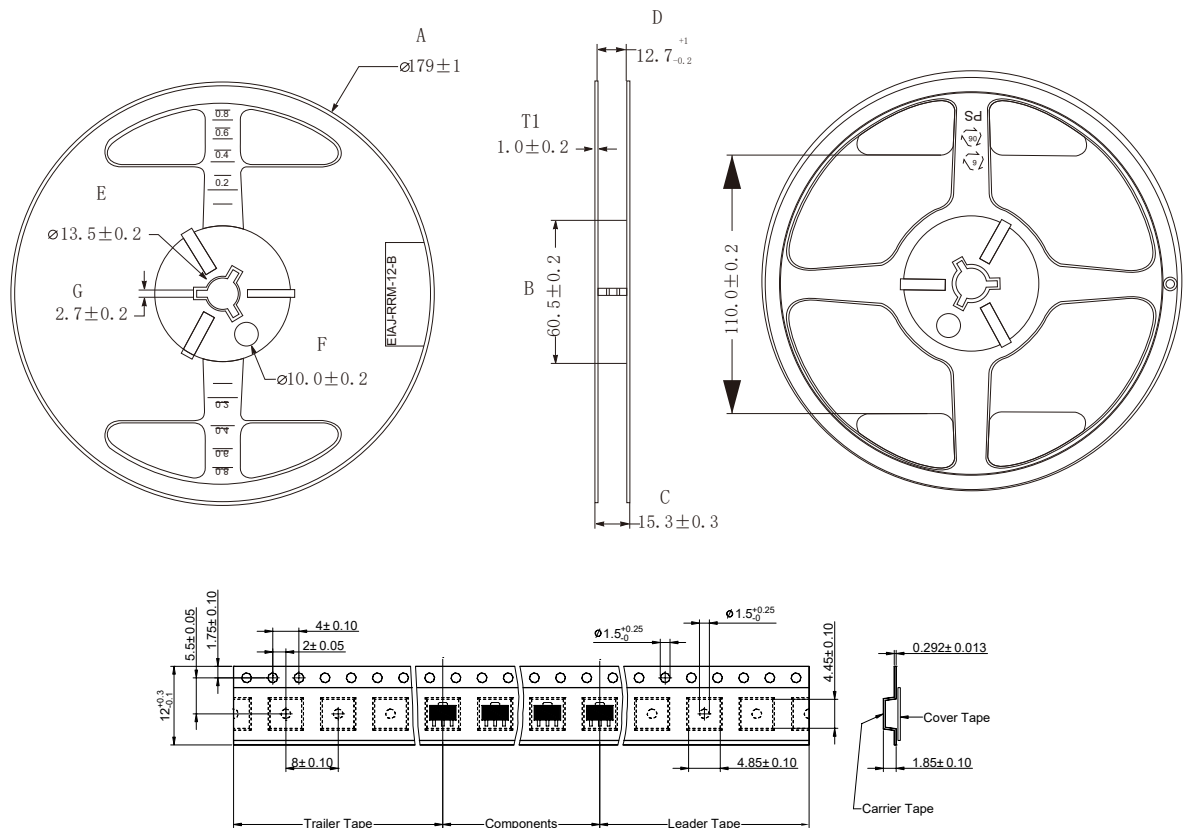

X-ON Electronics

Largest Supplier of Electrical and Electronic Components

Click to view similar products for [LDO Voltage Regulators](#) category:

Click to view products by [Pingjingsemi](#) manufacturer:

Other Similar products are found below :

[M38D29FFHP#U1](#) [702103A](#) [717726C](#) [742457H](#) [MP20051DN-LF-Z](#) [R5F111PGGFB#30](#) [AP7363-SP-13](#) [NCP103AMX285TCG](#)
[NCV8664CST33T3G](#) [NCV8752AMX28TCG](#) [L9454](#) [AP7362-HA-7](#) [LX13043CLD](#) [TCR3DF185,LM\(CT](#) [TCR3DF24,LM\(CT](#)
[TCR3DF285,LM\(CT](#) [TCR3DF31,LM\(CT](#) [TCR3DF45,LM\(CT](#) [TLF4949EJ](#) [L9708](#) [L970813TR](#) [030014BB](#) [059985X](#) [EAN61387601](#)
[EAN61573601](#) [NCP121AMX173TCG](#) [NCP4687DH15T1G](#) [NCV8703MX30TCG](#) [701326R](#) [702087BB](#) [755078E](#) [TCR2EN28,LF\(S](#)
[LM1117DT-1.8/NO](#) [LT1086CM#TRPBF](#) [AZ1085S2-1.5TRE1](#) [MAX15101EWL+T](#) [NCV8170AXV250T2G](#) [SCD337BTG](#)
[TCR3DF27,LM\(CT](#) [TCR3DF19,LM\(CT](#) [TCR3DF125,LM\(CT](#) [TCR2EN18,LF\(S](#) [MAX15103EWL+T](#) [TS2937CZ-5.0 C0](#) [MAX8878EUK30-](#)
[T](#) [MAX663CPA](#) [NCV4269CPD50R2G](#) [NCV8716MT30TBG](#) [AZ1117IH-1.2TRG1](#) [MP2013GQ-P](#)