



### Description

The PJ75B Series are a set of three-terminal low power high voltage regulators implemented in CMOS technology. They allow input voltages as high as 36V.

The PJ75B Series are designed specifically for portable battery-powered applications which require ultra-low quiescent current. The very-low consumption of type 2.5 $\mu$ A ensures long battery life and dynamic transient boost feature improves device transient response for wireless communication applications.

The device features integrated short-circuit and thermal shutdown protection.

### Features

- Wide Input Voltage Range: 3V~36V
- Maximum Output Current: 200mA
- Standard Fixed Output Voltage Options: 1.8V,2.5V,3.0V,3.3V,3.6V,5V
- Low Quiescent Current: 2.5 $\mu$ A
- PSRR=68dB@1KHz
- Low Dropout: 620mV @ 100mA,  $V_{OUT}=3.3V$
- Low Output Voltage Accuracy:  $\pm 2\%$
- Short Circuit Protection
- Thermal Shutdown Protection
- Available Packages: SOT-23, SOT-23-3, SOT-89, SOT-23-5 and DFN2x2C-6L

### Applications

- Battery-Powered Equipment
- Ultra Low Power Microcontrollers
- Security Monitoring Equipment

### Typical Application Circuit

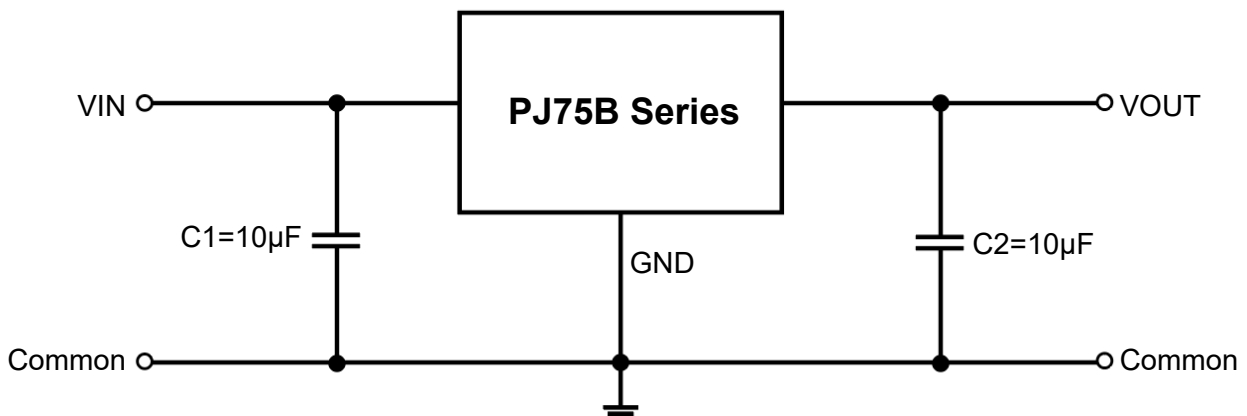

### Pin Distribution

**SOT-23**

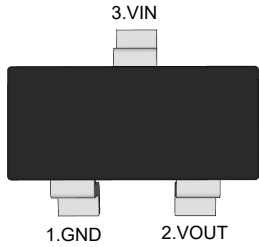

(Top View)

**SOT-89**

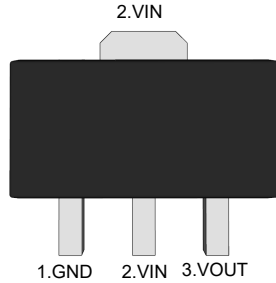

(Top View)

**SOT-23-3**

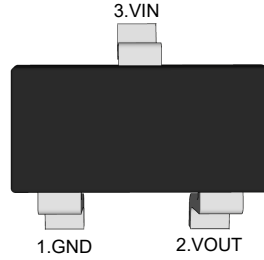

(Top View)

**SOT-23-5**

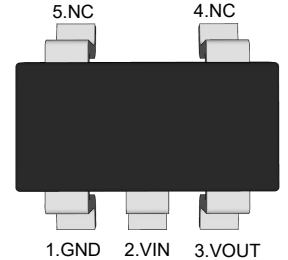

(Top View)

**DFN2x2C-6L**

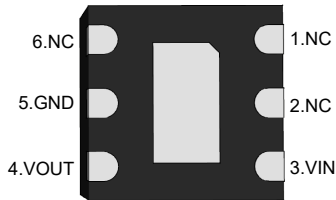

Bottom View

### Functional Pin Description

Pin Name	Pin Function
NC	NO Connected
GND	Ground
VOUT	Output Voltage
VIN	Power Input Voltage

### Ordering Information

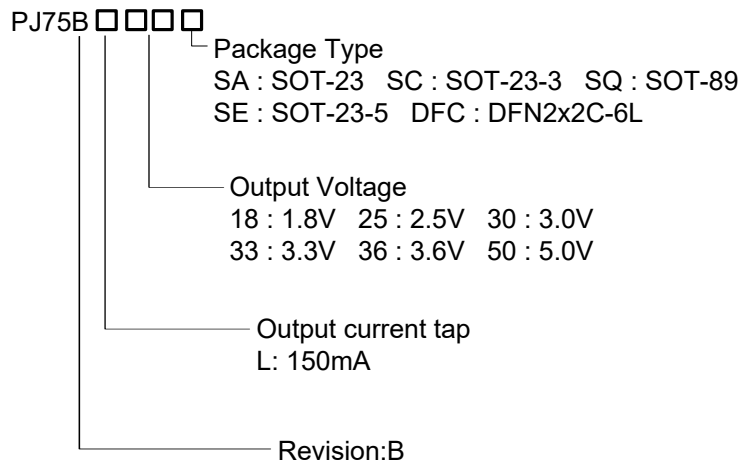



# PJ75B Series Low Dropout Regulators

## Ordering Information Continue

Orderable Device	Package	Reel (inch)	Package Qty (PCS)	Eco Plan <sup>Note</sup>	MSL Level	Marking Code
PJ75BL18SA	SOT-23	7	3000	RoHS & Green	MSL1	 XX:Output Voltage e.g. 30:3.0V
PJ75BL25SA						
PJ75BL30SA						
PJ75BL33SA						
PJ75BL36SA						
PJ75BL50SA						
PJ75BL18SQ	SOT-89	7/13	1000/3000	RoHS & Green	MSL1	 XX:Output Voltage e.g. 30:3.0V
PJ75BL25SQ						
PJ75BL30SQ						
PJ75BL33SQ						
PJ75BL36SQ						
PJ75BL50SQ						
PJ75BL18SC	SOT-23-3	7	3000	RoHS & Green	MSL3	 XX:Output Voltage e.g. 30:3.0V
PJ75BL25SC						
PJ75BL30SC						
PJ75BL33SC						
PJ75BL36SC						
PJ75BL50SC						
PJ75BL18SE	SOT-23-5	7	3000	RoHS & Green	MSL3	 XX:Output Voltage e.g. 30:3.0V
PJ75BL25SE						
PJ75BL30SE						
PJ75BL33SE						
PJ75BL36SE						
PJ75BL50SE						
PJ75BL18DFC	DFN2x2C-6L	7	3000	RoHS & Green	MSL1	 XX:Output Voltage e.g. 30:3.0V
PJ75BL25DFC						
PJ75BL30DFC						
PJ75BL33DFC						
PJ75BL36DFC						
PJ75BL50DFC						

### Note:

RoHS: PJ defines "RoHS" to mean semiconductor products that are compliant with the current EU RoHS requirements for all 10 RoHS substances, including the requirement that RoHS substance do not exceed 0.1% by weight in homogeneous materials.

Green: PJ defines "Green" to mean Halogen-Free and Antimony-Free.

### Function Block Diagram

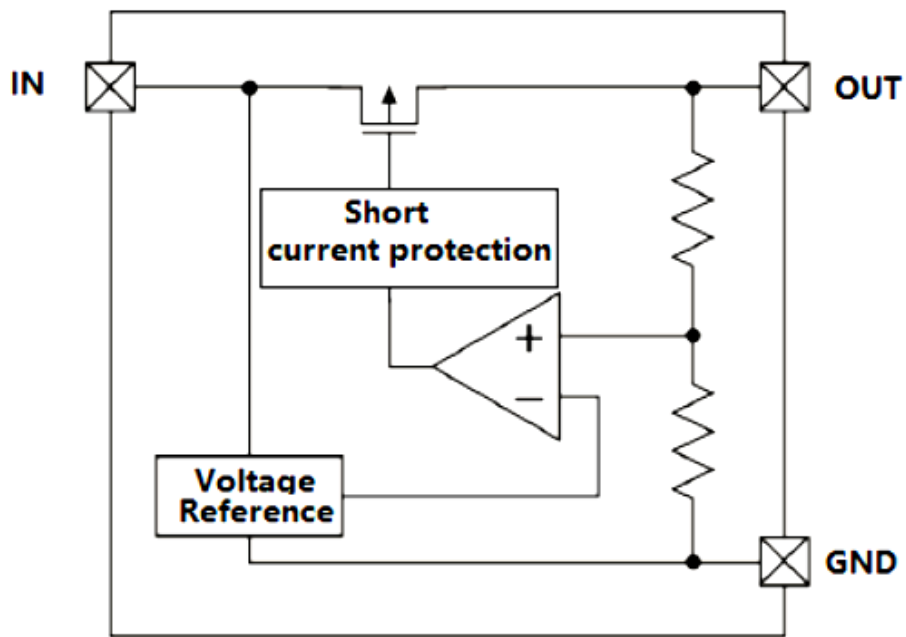



### Absolute Maximum Ratings

Ratings at 25°C ambient temperature unless otherwise specified.

Parameter		Value	Unit
Supply Voltage		-0.3 ~ +40	V
Power Dissipation	SOT-23	300	mW
	SOT-23-3	400	mW
	SOT-23-5	400	mW
	SOT-89	600	mW
	DFN2x2C-6L	1000	mW
Thermal Resistance, Junction-to-Ambient	SOT-23	330	°C/W
	SOT-23-3	380	°C/W
	SOT-23-5	380	°C/W
	SOT-89	180	°C/W
	DFN2x2C-6L	100	°C/W
Operating Junction Temperature		-40 ~ +125	°C
Storage Temperature Range		-65 ~ +150	°C
Lead Temperature (Soldering, 10 sec)		300	°C
ESD Voltage	HBM	±4000	V

Note1: Exceed these limits to damage to the device. Exposure to absolute maximum rating conditions may affect.

### Recommended Operating Conditions

Parameter	Value	Unit
Supply Voltage	3~36	V
Maximum Output Current	200	mA
Operating Ambient Temperature	-40 ~ +125	°C



### Electrical Characteristics

( $V_{IN}=V_{OUT}+2V$ ,  $C_{IN}=10\mu F$ ,  $C_{OUT}=10\mu F$ ,  $T_A=25^\circ C$ , unless otherwise noted.)

Parameter	Symbol	Test Conditions	Min.	Typ.	Max.	Unit	
Input Voltage	$V_{IN}$		3	--	36	V	
Output Voltage Accuracy	$\Delta V_{OUT}$	$I_{OUT}=1mA$	-2	--	+2	%	
Maximum Output Current	$I_{OUT(Max)}$		--	200	--	mA	
Quiescent Current	$I_Q$	$I_{OUT}=0mA$	--	2.5	4	$\mu A$	
Dropout Voltage	$V_{DROP}$	$V_{OUT}=2.5V$	$I_{OUT}=150mA$	--	900	1350	mV
			$I_{OUT}=100mA$	--	600	1000	mV
		$V_{OUT}=3.0V$	$I_{OUT}=150mA$	--	910	960	mV
			$I_{OUT}=100mA$	--	650	700	mV
		$V_{OUT}=3.3V$	$I_{OUT}=150mA$	--	895	950	mV
			$I_{OUT}=100mA$	--	620	680	mV
		$V_{OUT}=3.6V$	$I_{OUT}=150mA$	--	755	930	mV
			$I_{OUT}=100mA$	--	500	660	mV
$V_{OUT}=5.0V$	$I_{OUT}=150mA$	--	810	990	mV		
	$I_{OUT}=100mA$	--	510	600	mV		
Line Regulation	$\Delta V_{LINE}$	$V_{IN}=V_{OUT}+2V$ to 30V $I_{OUT}=10mA$	--	--	0.2	%/V	
Load Regulation	$\Delta V_{LOAD}$	$V_{IN}=V_{OUT}+2V$ , $1mA < I_{OUT} < 150mA$	--	5	20	mV	
Short Current Protection	$I_{Short}$	OUT Short to GND	--	100	--	mA	
Output Noise	$e_N$	10Hz to 100KHz $I_{OUT}=30mA$	--	120	--	$\mu V_{RMS}$	
Power Supply Rejection Ratio	PSRR	$V_{IN}=12V$ , $I_{OUT}=1mA$ , $f=1KHz$	--	68	--	dB	



## Typical Characteristics Curves

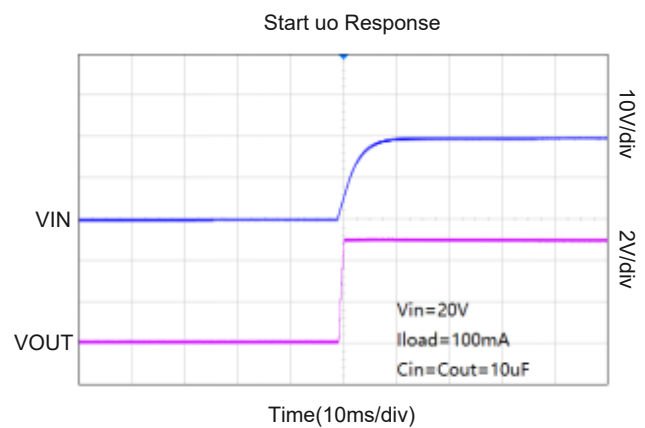
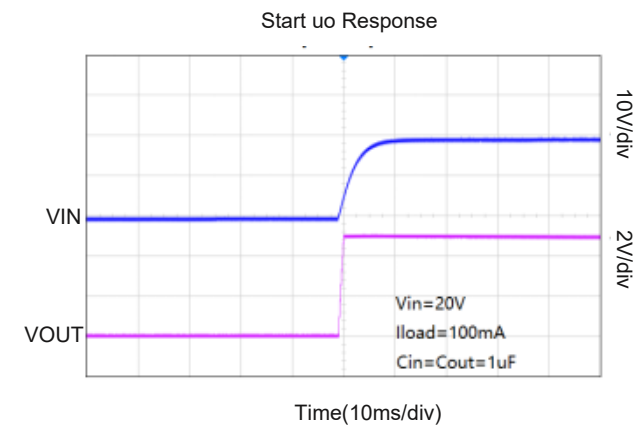
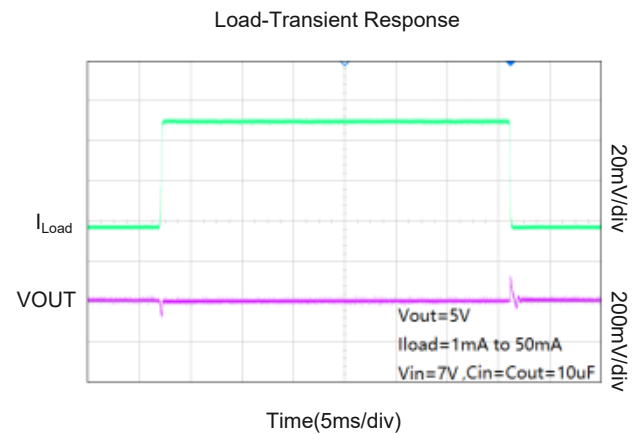
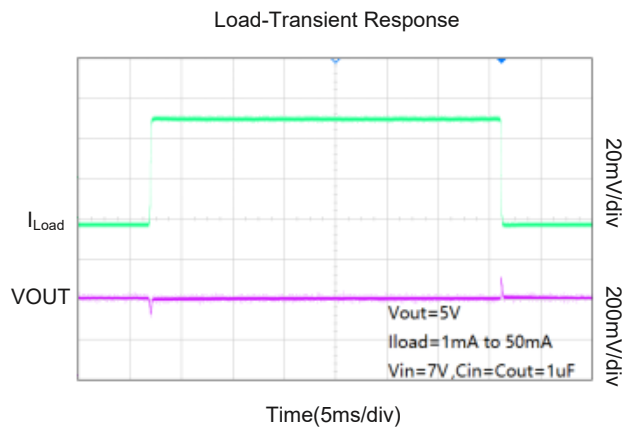
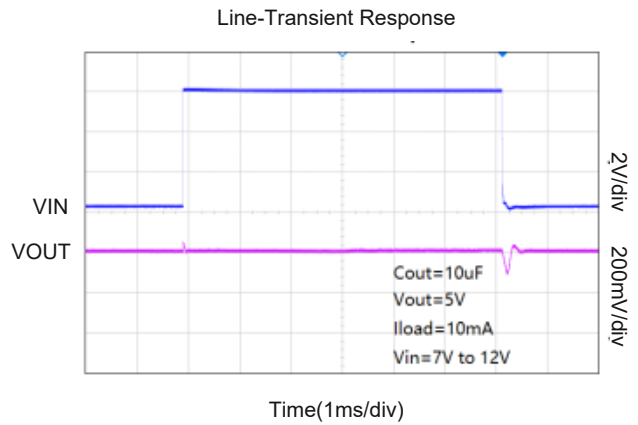
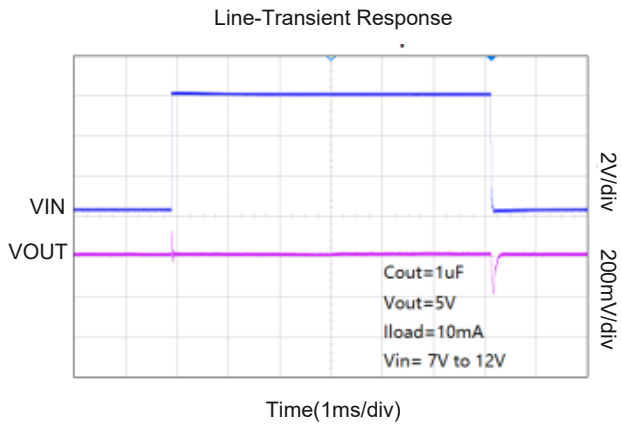



# PJ75B Series Low Dropout Regulators

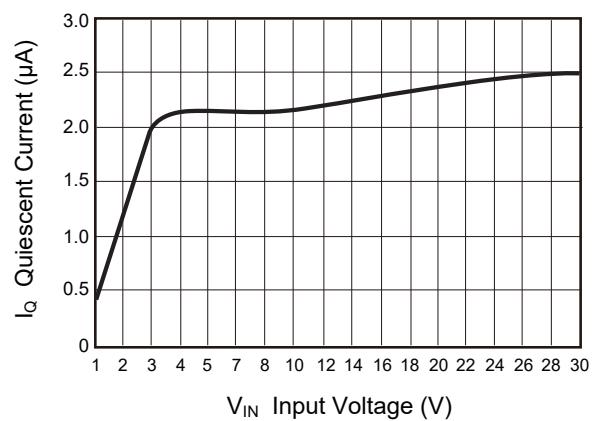
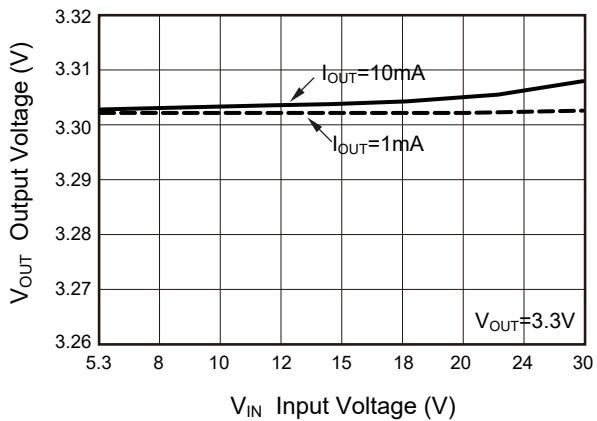
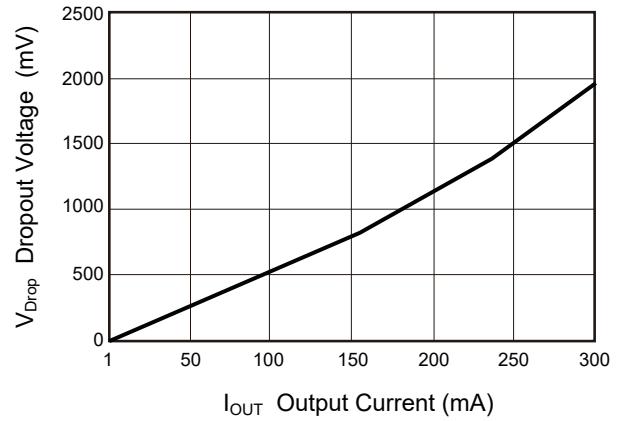
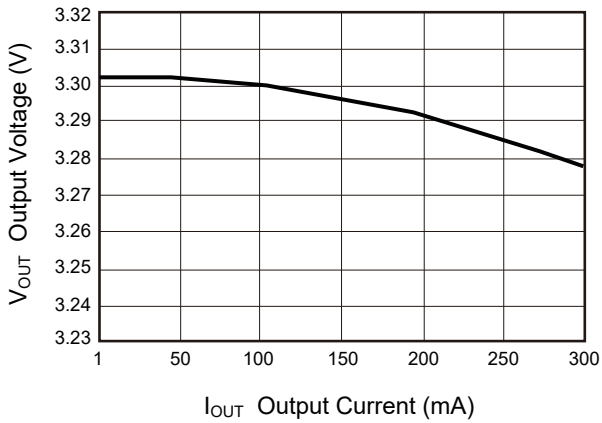
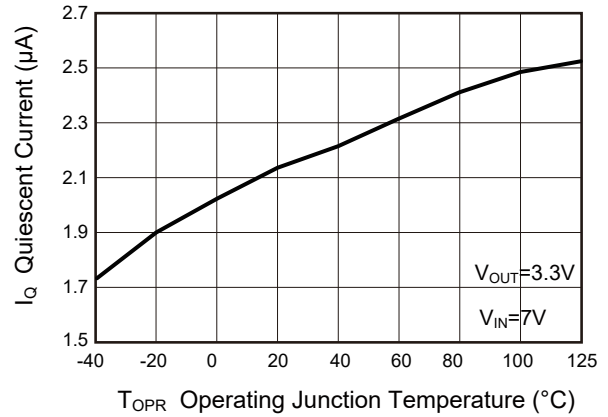
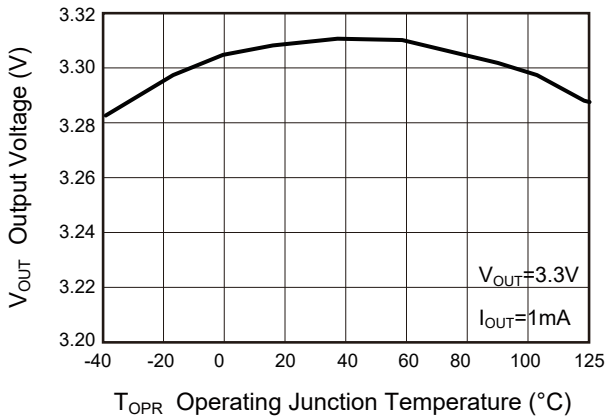





## Functional Description

### Input Capacitor

A  $1\mu\text{F}$ ~ $10\mu\text{F}$  ceramic capacitor is recommended to connect between VIN and GND pins to decouple input power supply glitch and noise. The amount of the capacitance may be increased without limit. This input capacitor must be located as close as possible to the device to assure input stability and less noise. For PCB layout, a wide copper trace is required for both VIN and GND.

### Output Capacitor

An output capacitor is required for the stability of the LDO. The recommended output capacitance is from  $1\mu\text{F}$  to  $10\mu\text{F}$ , Equivalent Series Resistance (ESR) is from  $5\text{m}\Omega$  to  $100\text{m}\Omega$ , and temperature characteristics are X7R or X5R. Higher capacitance values help to improve load/line transient response. The output capacitance may be increased to keep low undershoot/overshoot. Place output capacitor as close as possible to OUT and GND pins.

### Low Quiescent Current

The PJ75B Series consuming only around  $2.5\mu\text{A}$  for all input range and output loading, provides great power saving in portable and low power applications.

### Short Current Limit Protection

When output current at the OUT pin is higher than current limit threshold or the OUT pin is short-circuit to GND, the short current limit protection will be triggered and clamp the output current to approximately  $80\text{mA}$  to prevent over-current and to protect the regulator from damage due to overheating.

### Package Outline

SOT-23

Dimensions in mm

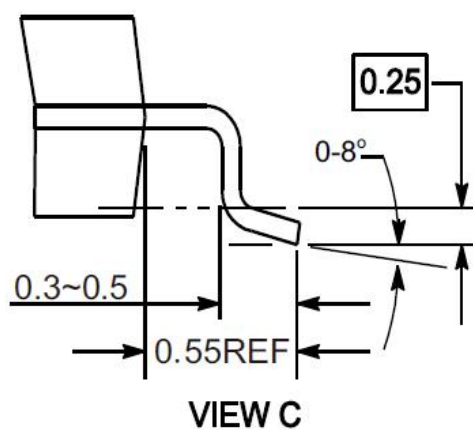
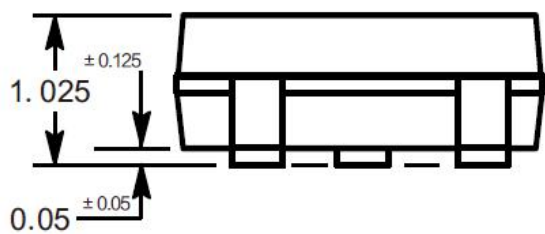
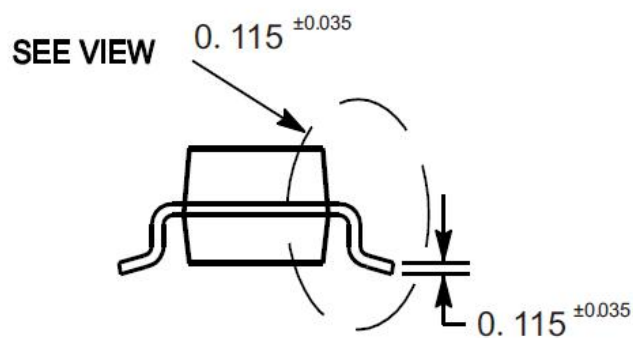
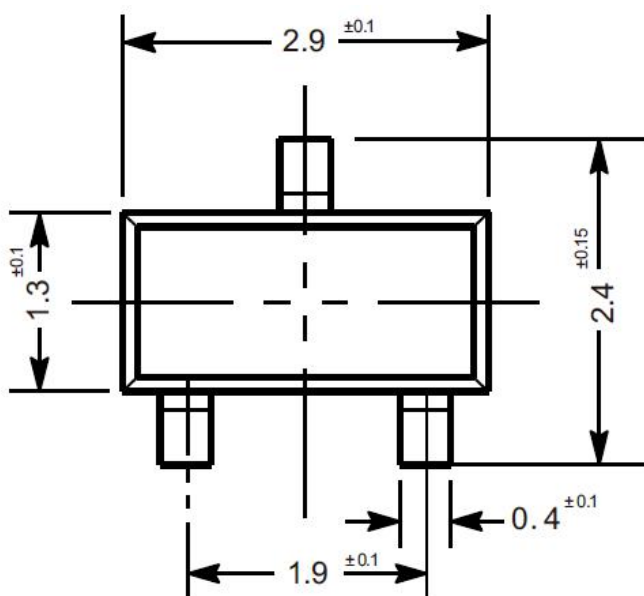



# PJ75B Series Low Dropout Regulators

## Package Outline

SOT-23-3

Dimensions in mm

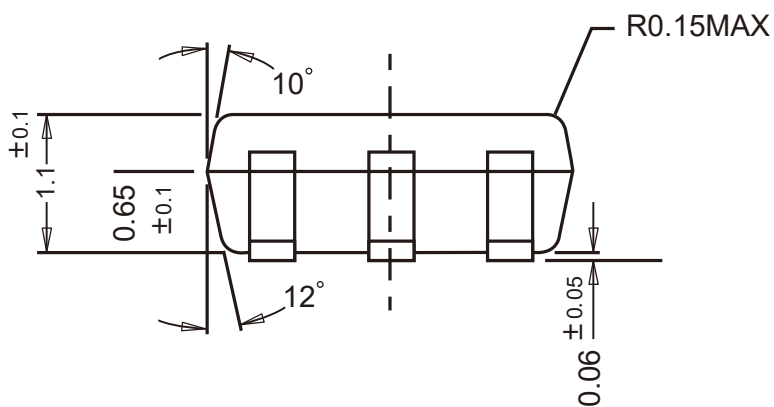
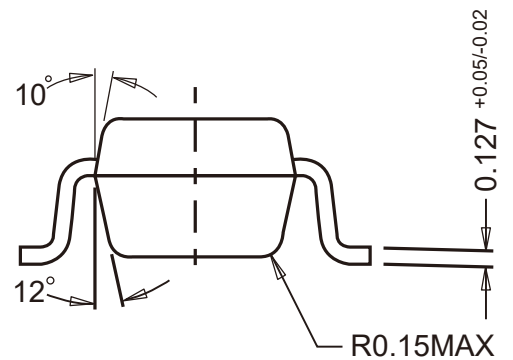
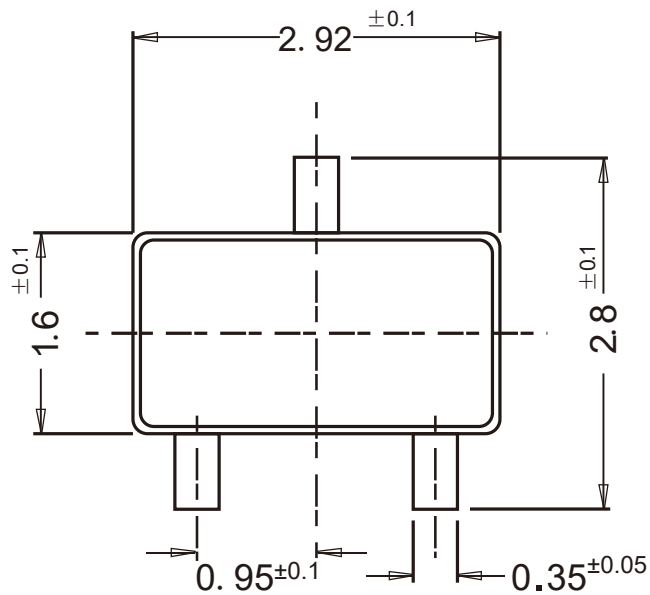



### Package Outline

SOT-89

Dimensions in mm

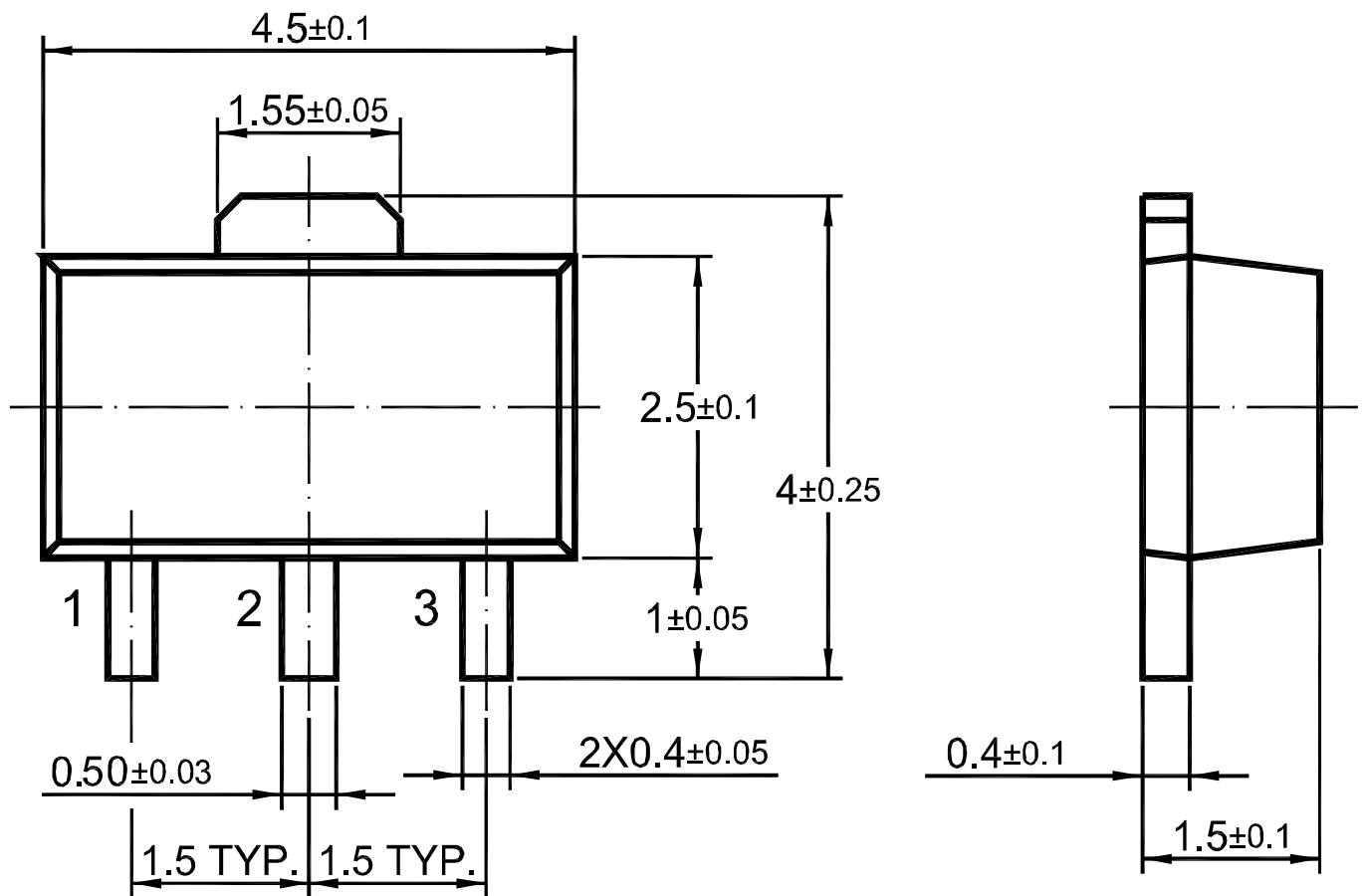



# PJ75B Series Low Dropout Regulators

## Package Outline

SOT-23-5

Dimensions in mm

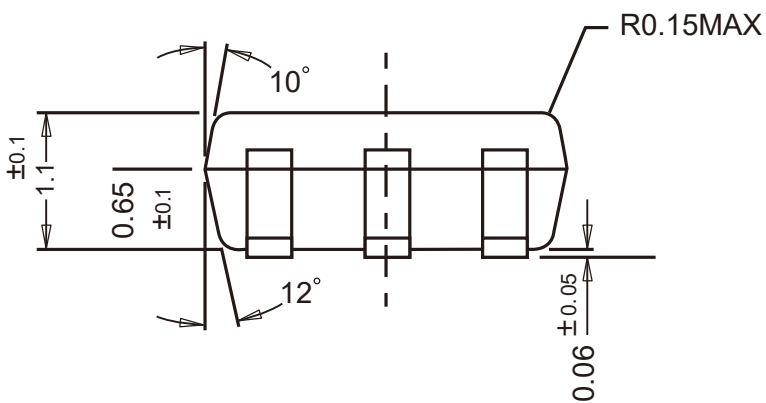
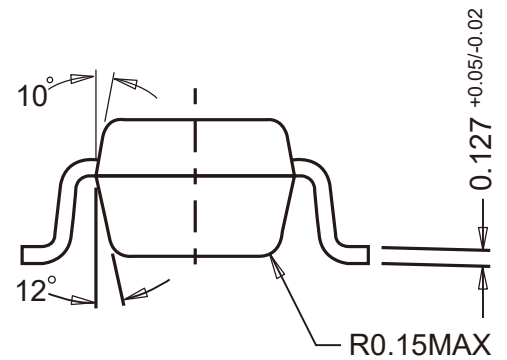
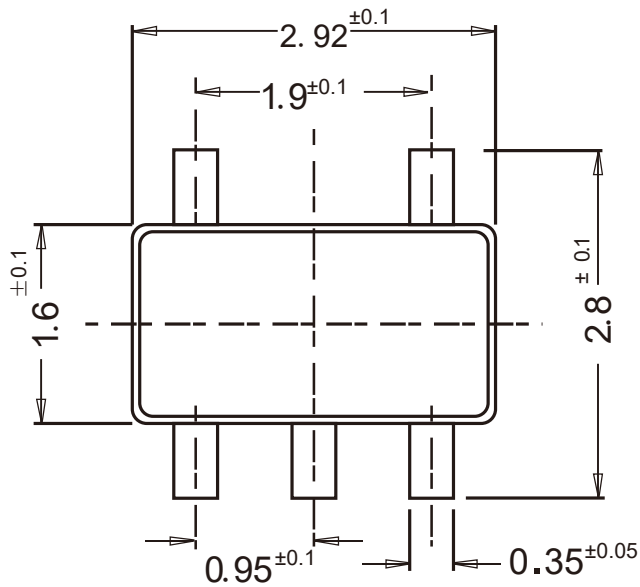

### Package Outline

DFN2x2C-6L

Dimensions in mm

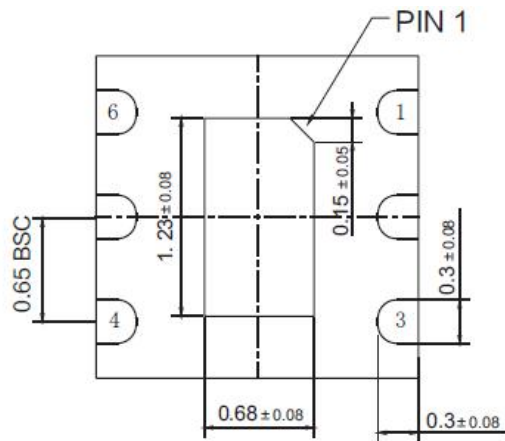

BOTTOM VIEW

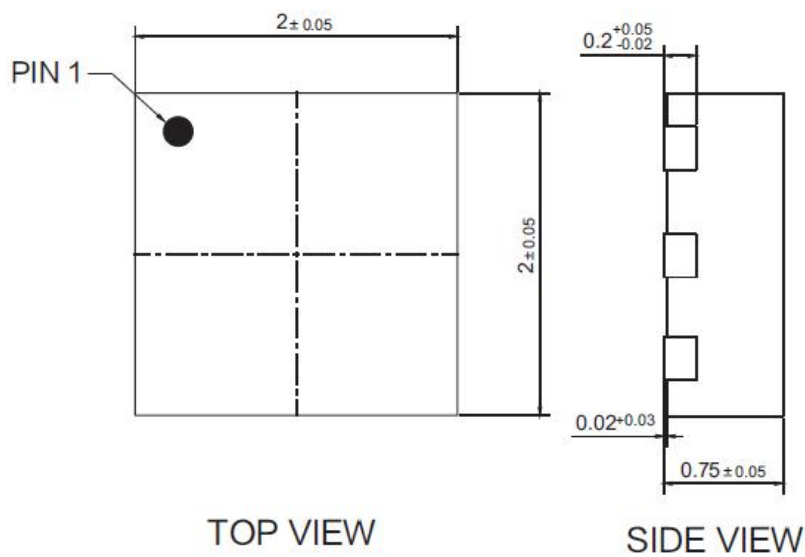

TOP VIEW

SIDE VIEW

## X-ON Electronics

Largest Supplier of Electrical and Electronic Components

*Click to view similar products for [Linear Voltage Regulators](#) category:*

*Click to view products by [Pingjingsemi](#) manufacturer:*

Other Similar products are found below :

[LV5684PVD-XH](#) [MCDTSA6-2R](#) [L7815ACV-DG](#) [LV56801P-E](#) [UA7805CKC](#) [714954EB](#) [ZMR500QFTA](#) [BA033LBSG2-TR](#)  
[NCV78M05ABDTRKG](#) [LV5680P-E](#) [L79M05T-E](#) [L78LR05D-MA-E](#) [NCV317MBTG](#) [NTE7227](#) [MP2018GZD-33-P](#) [MP2018GZD-5-P](#)  
[LV5680NPVC-XH](#) [ZTS6538SE](#) [UA78L09CLP](#) [UA78L09CLPR](#) [CAT6221-PPTD-GT3](#) [MC78M09CDTRK](#) [NCV51190MNTAG](#)  
[BL1118CS8TR1833](#) [BL8077CKETR33](#) [BL9153-33CC3TR](#) [BL9161G-28BADRN](#) [BRCO7530MMC](#) [CJ7815B-TFN-ARG](#) [LM317C](#)  
[GM7333K](#) [GM7350K](#) [XC6206P332MR](#) [HT7533](#) [LM7912S/TR](#) [LT1764S/TR](#) [LM7805T](#) [LM338T](#) [LM1117IMP-3.3/TR](#) [HT1117AM-3.3](#)  
[HT7550S](#) [AMS1117-3.3](#) [HT7150S](#) [78L12](#) [HT7550](#) [HT7533-1](#) [HXY6206I-2.5](#) [HT7133](#) [HT7533S](#) [662K](#)