



# PJM12P30PA

## P-Channel Enhancement Mode Power MOSFET

### Features

- High density cell design for ultra low  $R_{DS(on)}$
- Excellent package for good heat dissipation
- $V_{DS} = -30V, I_D = -12A$   
 $R_{DS(on)} < 10.5m\Omega @ V_{GS} = -10V$

### Applications

- Power switching application
- Hard switched and high frequency circuits
- Uninterruptible power supply

### Absolute Maximum Ratings

Ratings at 25°C ambient temperature unless otherwise specified.

Parameter	Symbol	Value	Unit
Drain-Source Voltage	$-V_{DS}$	30	V
Gate-Source Voltage	$-V_{GS}$	$\pm 20$	V
Drain Current-Continuous	$-I_D$	12	A
Drain Current-Pulsed <sup>Note1</sup>	$-I_{DM}$	48	A
Maximum Power Dissipation	$P_D$	3	W
Junction Temperature	$T_J$	150	°C
Storage Temperature Range	$T_{STG}$	-55 to +150	°C

### Thermal Characteristics

Maximum Junction-to-Case <sup>Note2</sup>	$R_{\theta JC}$	41.7	°C/W
---	-----------------	------	------

### SOP-8

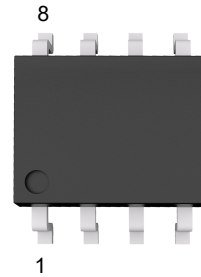

Marking code: 4407

### Schematic Diagram

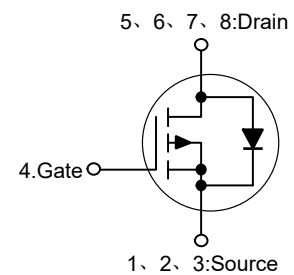

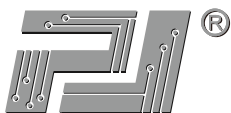

# PJM12P30PA

## P-Channel Enhancement Mode Power MOSFET

### Electrical Characteristics

(Ta=25°C unless otherwise specified)

Parameter	Symbol	Test Condition	Min.	Typ.	Max.	Unit
<b>Static Characteristics</b>						
Drain-Source Breakdown Voltage	$-V_{(BR)DSS}$	$V_{GS}=0V, I_D=-250\mu A$	30	--	--	V
Zero Gate Voltage Drain Current	$-I_{DSS}$	$V_{DS}=-30V, V_{GS}=0V$	--	--	1	$\mu A$
Gate-Body Leakage Current	$I_{GSS}$	$V_{GS}=\pm 20V, V_{DS}=0V$	--	--	$\pm 100$	nA
Gate Threshold Voltage <sup>Note3</sup>	$-V_{GS(th)}$	$V_{DS}=V_{GS}, I_D=-250\mu A$	1	--	3	V
Drain-Source On-Resistance <sup>Note3</sup>	$R_{DS(on)}$	$V_{GS}=-10V, I_D=-12A$	--	8.5	10.5	m $\Omega$
		$V_{GS}=-4.5V, I_D=-10A$	--	10	12	m $\Omega$
Forward Transconductance <sup>Note3</sup>	$g_{FS}$	$V_{DS}=-5V, I_D=-10A$	20	--	--	S
<b>Dynamic Characteristics</b>						
Input Capacitance	$C_{iss}$	$V_{DS}=-15V, V_{GS}=0V, f=1MHz$	--	1800	--	pF
Output Capacitance	$C_{oss}$		--	220	--	pF
Reverse Transfer Capacitance	$C_{rss}$		--	180	--	pF
<b>Switching Characteristics</b>						
Turn-on Delay Time	$t_{d(on)}$	$V_{DD}=-15V, V_{GS}=-10V$ $I_D=-10A, R_{GEN}=3\Omega$	--	10	--	nS
Turn-on Rise Time	$t_r$		--	9	--	nS
Turn-off Delay Time	$t_{d(off)}$		--	26	--	nS
Turn-off Fall Time	$t_f$		--	11	--	nS
Total Gate Charge	$Q_g$	$V_{DS}=-15V, V_{GS}=-10V, I_D=-10A$	--	25	--	nC
Gate-Source Charge	$Q_{gs}$		--	4	--	nC
Gate-Drain Charge	$Q_{gd}$		--	6	--	nC
<b>Source-Drain Diode Characteristics</b>						
Diode Forward Voltage <sup>Note3</sup>	$-V_{SD}$	$V_{GS}=0V, I_S=-12A$	--	--	1.5	V
Diode Forward Current <sup>Note2</sup>	$-I_S$		--	--	12	A

Note: 1. Repetitive Rating: Pulse width limited by maximum junction temperature.

2. Surface Mounted on FR4 Board,  $t \leq 10$  sec.

3. Pulse Test: Pulse width  $\leq 300\mu s$ , duty cycle  $\leq 2\%$



# PJM12P30PA

## P-Channel Enhancement Mode Power MOSFET

### Typical Characteristic Curves

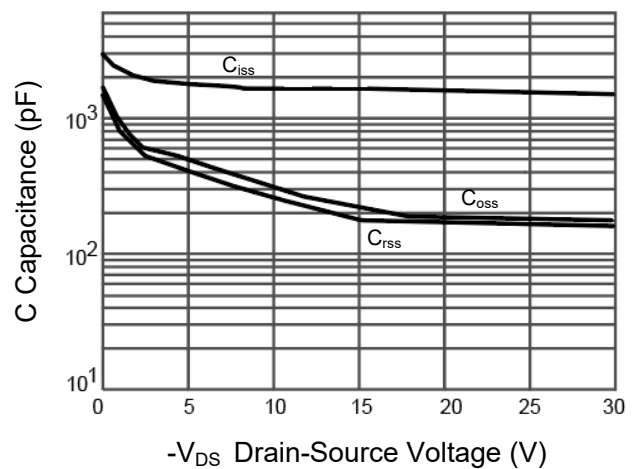
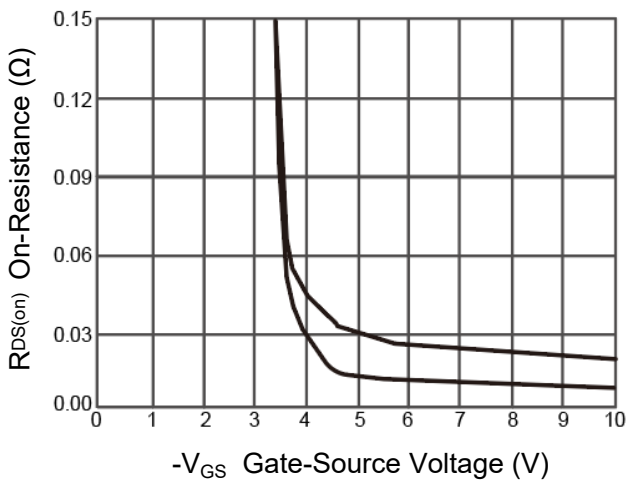
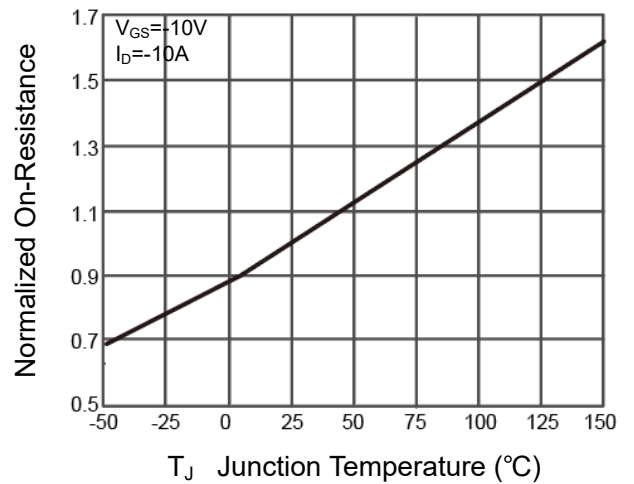
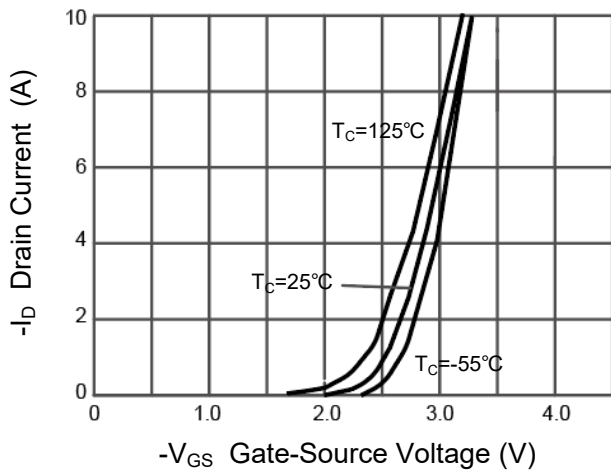
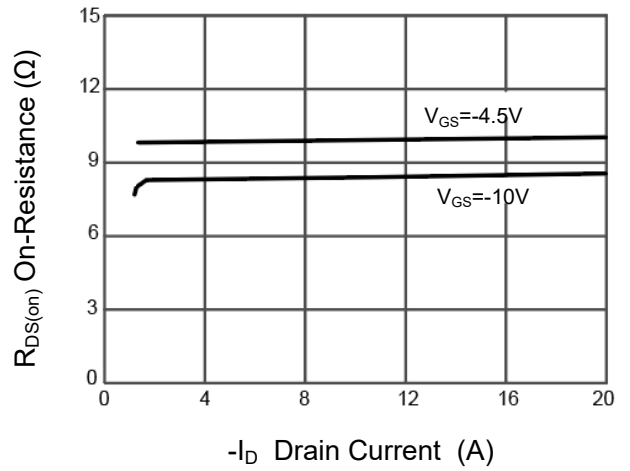
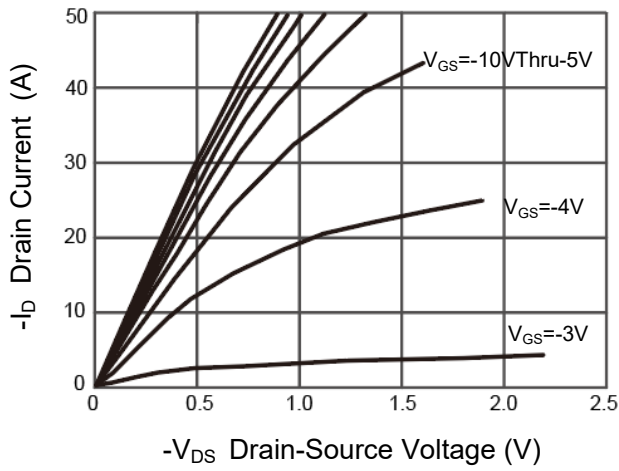



# PJM12P30PA

## P-Channel Enhancement Mode Power MOSFET

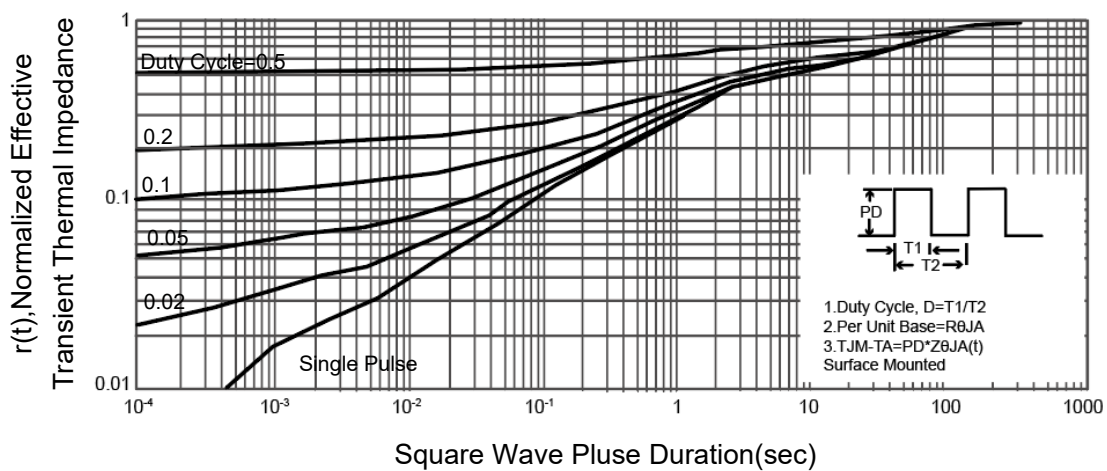
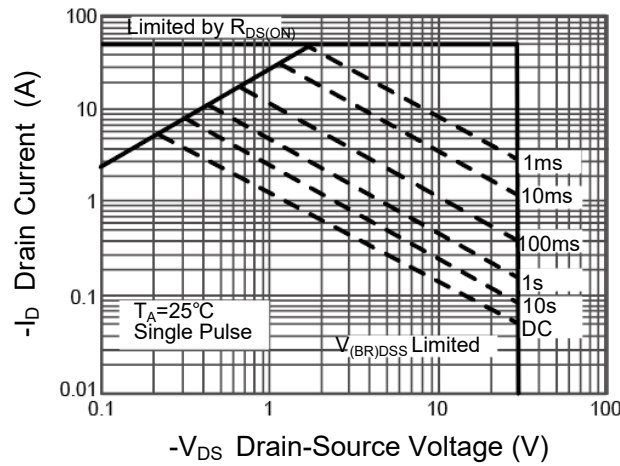
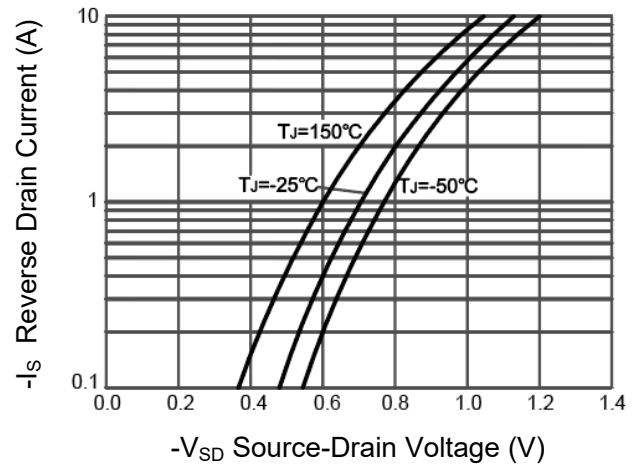
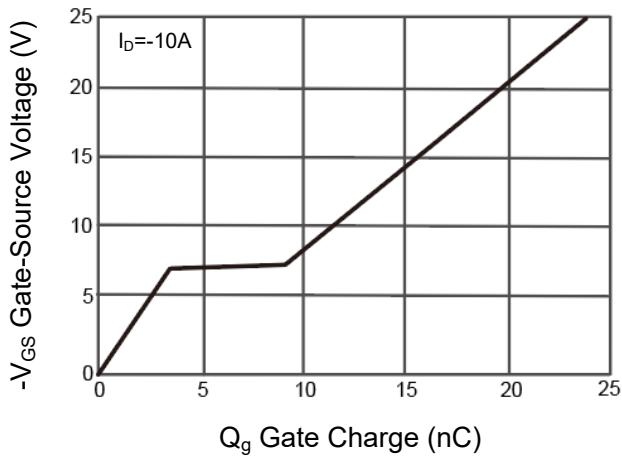



# PJM12P30PA

## P-Channel Enhancement Mode Power MOSFET

### Package Outline

SOP-8

Dimensions in mm

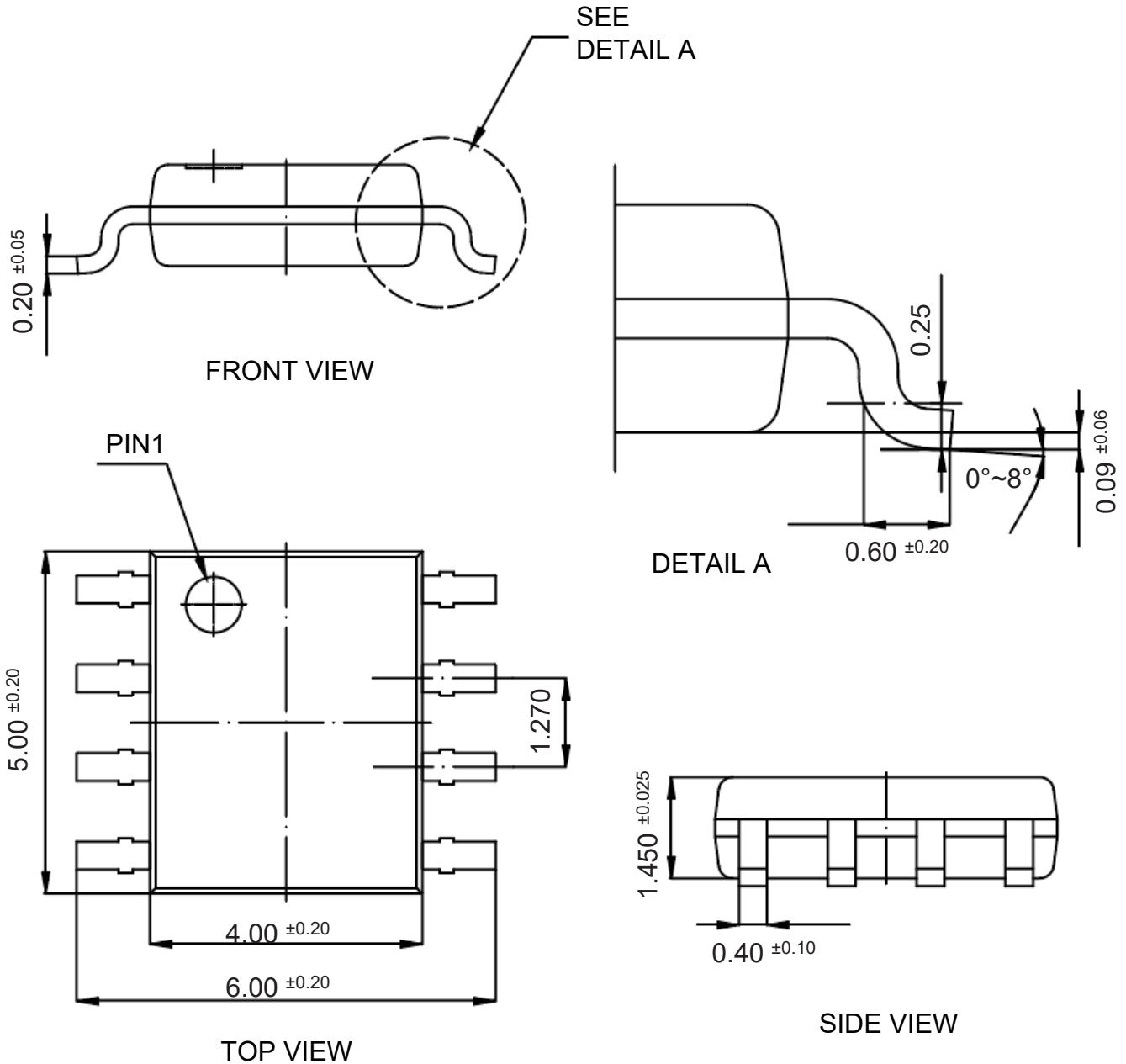

### Ordering Information

Device	Package	Shipping
PJM12P30PA	SOP-8	4,000PCS/Reel&13inches

## X-ON Electronics

Largest Supplier of Electrical and Electronic Components

*Click to view similar products for [MOSFET](#) category:*

*Click to view products by [Pingjingsemi](#) manufacturer:*

Other Similar products are found below :

[IRFD120](#) [JANTX2N5237](#) [BUK455-60A/B](#) [MIC4420CM-TR](#) [VN1206L](#) [NDP4060](#) [SI4482DY](#) [IPS70R2K0CEAKMA1](#) [SQD23N06-31L-GE3](#)  
[TK16J60W,S1VQ\(O](#) [2SK2614\(TE16L1,Q\)](#) [DMN1017UCP3-7](#) [DMN1053UCP4-7](#) [SQJ469EP-T1-GE3](#) [NTE2384](#) [DMC2700UDMQ-7](#)  
[DMN2080UCB4-7](#) [DMN61D9UWQ-13](#) [US6M2GTR](#) [DMN31D5UDJ-7](#) [DMP22D4UFO-7B](#) [DMN1006UCA6-7](#) [DMN16M9UCA6-7](#)  
[STF5N65M6](#) [IRF40H233XTMA1](#) [STU5N65M6](#) [DMN6022SSD-13](#) [DMN13M9UCA6-7](#) [DMTH10H4M6SPS-13](#) [DMN2990UFB-7B](#)  
[IPB80P04P405ATMA2](#) [2N7002W-G](#) [MCAC30N06Y-TP](#) [MCQ7328-TP](#) [NTMC083NP10M5L](#) [BXP7N65D](#) [BXP4N65F](#) [AOL1454G](#)  
[WMJ80N60C4](#) [BXP2N20L](#) [BXP2N65D](#) [BXT1150N10J](#) [BXT1700P06M](#) [TSM60NB380CP](#) [ROG](#) [RQ7L055BGTGR](#) [DMNH15H110SK3-13](#)  
[SLF10N65ABV2](#) [BSO203SP](#) [BSO211P](#) [IPA60R230P6](#)