



PJMG60P60TE

P-Channel Enhancement Mode Power MOSFET

Product Summary

- $V_{DS} = -60V, I_D = -60A$
- $R_{DS(on)} < 16m\Omega @ V_{GS} = -10V$
- $R_{DS(on)} < 20m\Omega @ V_{GS} = -4.5V$

Features

- Advanced Split Gate Trench Technology
- 100% Avalanche Tested
- RoHS Compliant
- Halogen and Antimony Free
- Moisture Sensitivity Level 3

Application

- DC-DC Converter
- Portable Equipment
- Power Management

Marking Code

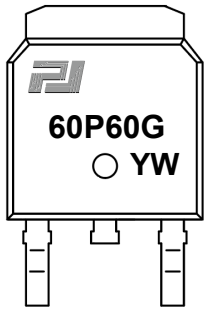

TO-252

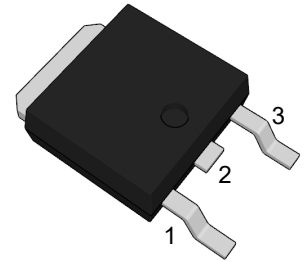

(Top View)

Pin	Description
1	Gate
2	Drain
3	Source

Schematic Diagram

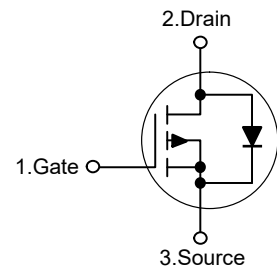

Absolute Maximum Ratings

Ratings at 25°C case temperature unless otherwise specified.

Parameter	Symbol	Value	Unit
Drain-Source Voltage	$-V_{DS}$	60	V
Gate-Source Voltage	V_{GS}	± 20	V
Drain Current-Continuous	$-I_D$	60	A
Drain Current-Pulsed ^{Note1}	$-I_{DM}$	220	A
Maximum Power Dissipation	P_D	100	W
Single Pulse Avalanche Energy ^{Note2}	E_{AS}	176	mJ
Junction Temperature	T_J	150	°C
Storage Temperature Range	T_{STG}	-55 to +150	°C

Thermal Characteristics

Thermal Resistance, Junction-to-Case	$R_{\theta JC}$	1.25	°C/W
--------------------------------------	-----------------	------	------



PJMG60P60TE

P-Channel Enhancement Mode Power MOSFET

Electrical Characteristics

($T_J=25^\circ\text{C}$ unless otherwise specified)

Parameter	Symbol	Test Condition	Min.	Typ.	Max.	Unit
Static Characteristics						
Drain-Source Breakdown Voltage	$-V_{(BR)DSS}$	$V_{GS}=0V, I_D=-250\mu\text{A}$	60	--	--	V
Zero Gate Voltage Drain Current	$-I_{DSS}$	$V_{DS}=-60V, V_{GS}=0V$	--	--	1	μA
Gate-Body Leakage Current	I_{GSS}	$V_{GS}=\pm 20V, V_{DS}=0V$	--	--	± 100	nA
Gate Threshold Voltage ^{Note3}	$-V_{GS(th)}$	$V_{DS}=V_{GS}, I_D=-250\mu\text{A}$	1	1.8	2.5	V
Drain-Source On-Resistance ^{Note3}	$R_{DS(on)}$	$V_{GS}=-10V, I_D=-20A$	--	11	16	m Ω
		$V_{GS}=-4.5V, I_D=-10A$	--	14	20	m Ω
Forward Transconductance ^{Note3}	g_{FS}	$V_{DS}=-5V, I_D=-2A$	--	9	--	S
Dynamic Characteristics						
Input Capacitance	C_{iss}	$V_{DS}=-30V, V_{GS}=0V, f=1\text{MHz}$	--	2634	--	pF
Output Capacitance	C_{oss}		--	506	--	pF
Reverse Transfer Capacitance	C_{rss}		--	22	--	pF
Gate Resistance	R_g	$V_{DS}=0V, V_{GS}=0V, f=1\text{MHz}$	--	11.5	--	Ω
Total Gate Charge	Q_g	$V_{DS}=-30V, I_D=-10A,$ $V_{GS}=-10V$	--	38	--	nC
Gate-Source Charge	Q_{gs}		--	6.9	--	nC
Gate-Drain Charge	Q_{gd}		--	4.98	--	nC
Switching Characteristics						
Turn-on Delay Time	$t_{d(on)}$	$V_{DD}=-30V, I_D=-10A,$ $V_{GS}=-10V, R_{GEN}=3\Omega$	--	20	--	nS
Turn-on Rise Time	t_r		--	25	--	nS
Turn-off Delay Time	$t_{d(off)}$		--	60	--	nS
Turn-off Fall Time	t_f		--	30	--	nS
Source-Drain Diode Characteristics						
Diode Forward Voltage ^{Note3}	$-V_{SD}$	$V_{GS}=0V, I_S=-30A$	--	--	1.2	V
Diode Forward Current	$-I_S$		--	--	60	A

Note: 1. Repetitive Rating: Pulse width limited by maximum junction temperature

2. EAS condition: $T_J=25^\circ\text{C}, V_{DD}=-30V, V_G=-10V, R_G=25\Omega, L=0.5\text{mH}, I_{AS}=-26.5A$

3. Pulse Test: Pulse Width $\leq 300\mu\text{s}$, Duty Cycle $\leq 2\%$



PJMG60P60TE

P-Channel Enhancement Mode Power MOSFET

Typical Characteristic Curves

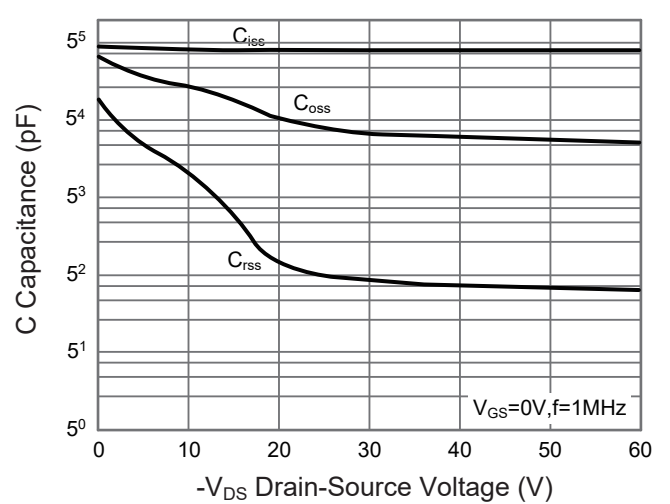
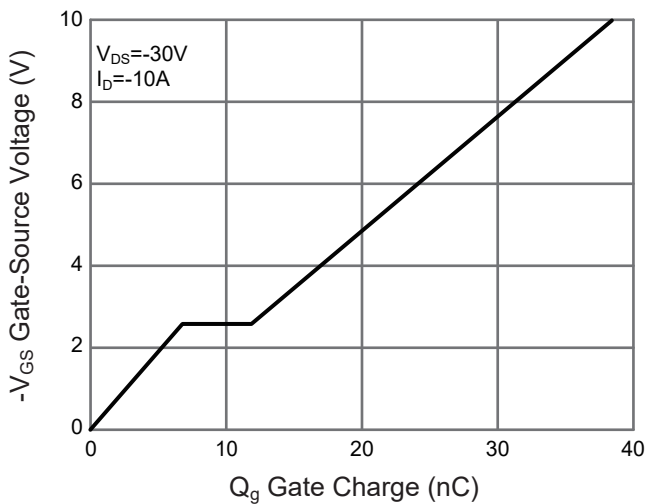
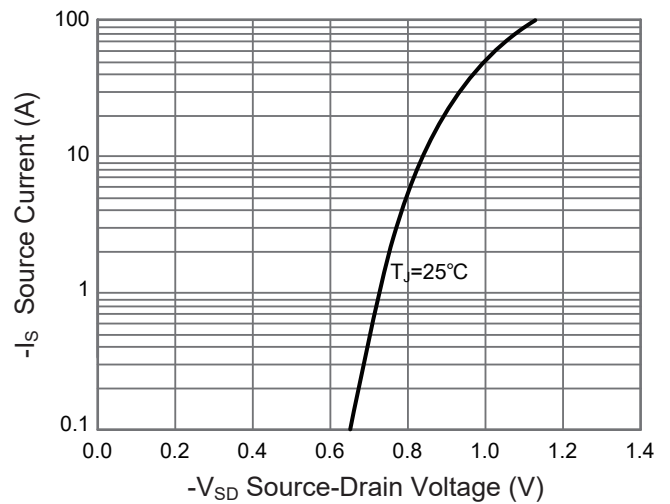
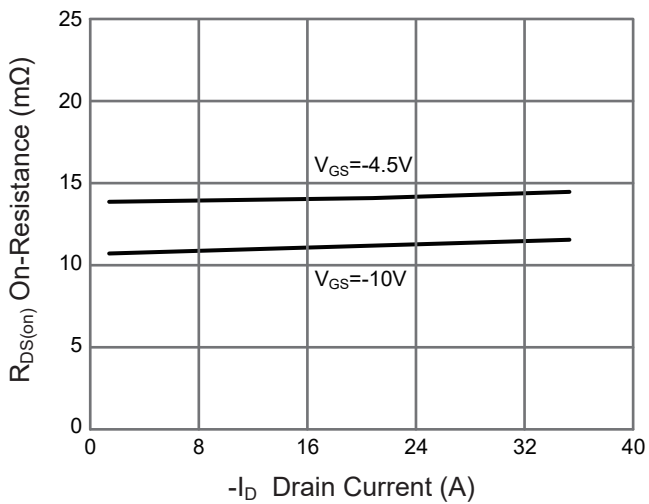
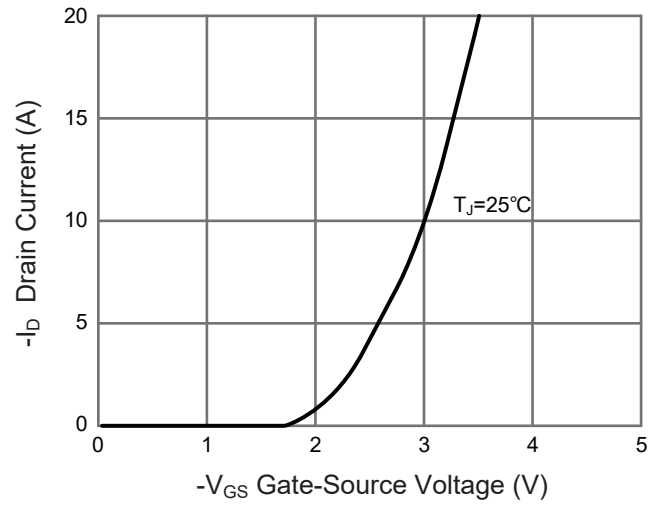
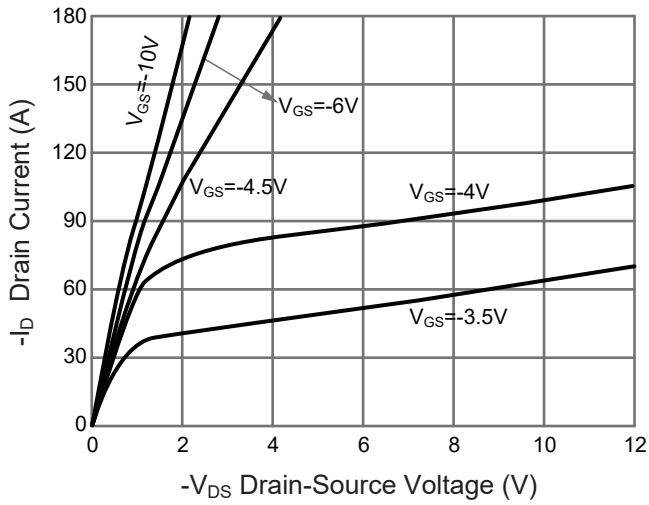



PJMG60P60TE

P-Channel Enhancement Mode Power MOSFET

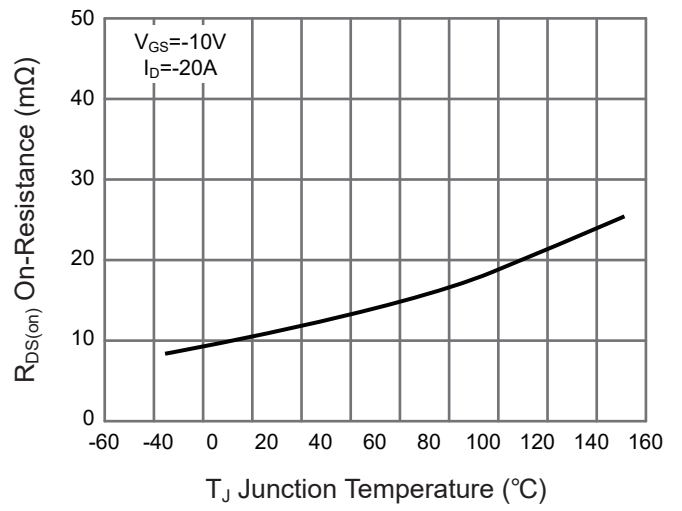
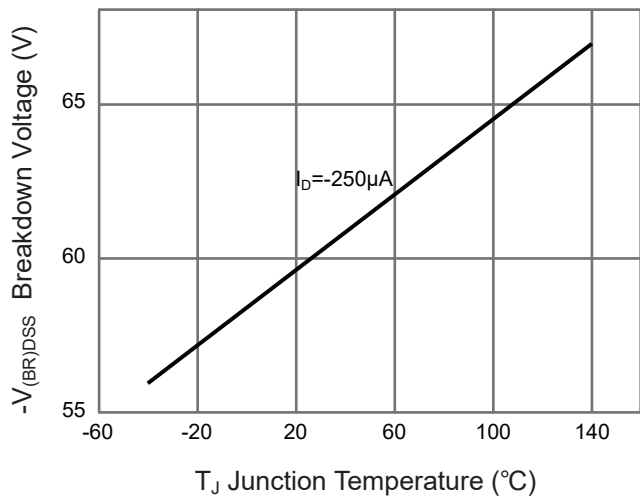



PJMG60P60TE

P-Channel Enhancement Mode Power MOSFET

Package Outline

TO-252

Dimensions in mm

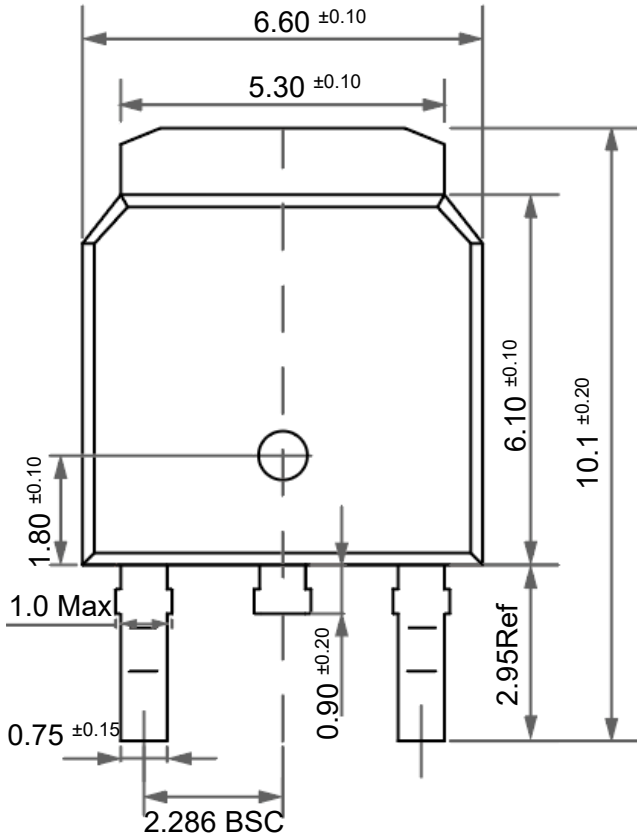

Front View

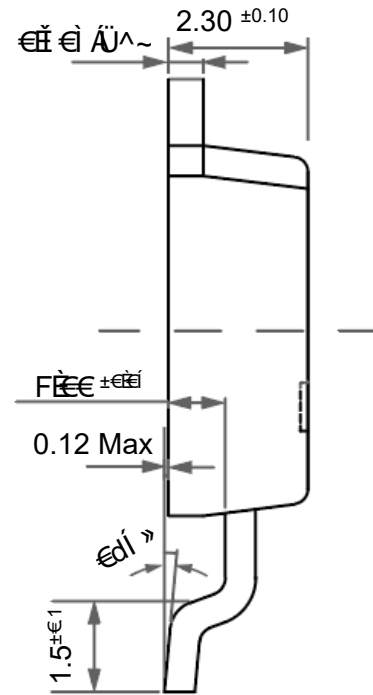

Side View

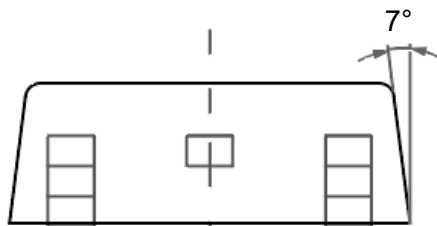

Bottom View

Ordering Information

Device	Package	Shipping
PJMG60P60TE	TO-252	2,500PCS/Reel&13inches



Conditions of Soldering and Storage

◆ Recommended condition of reflow soldering

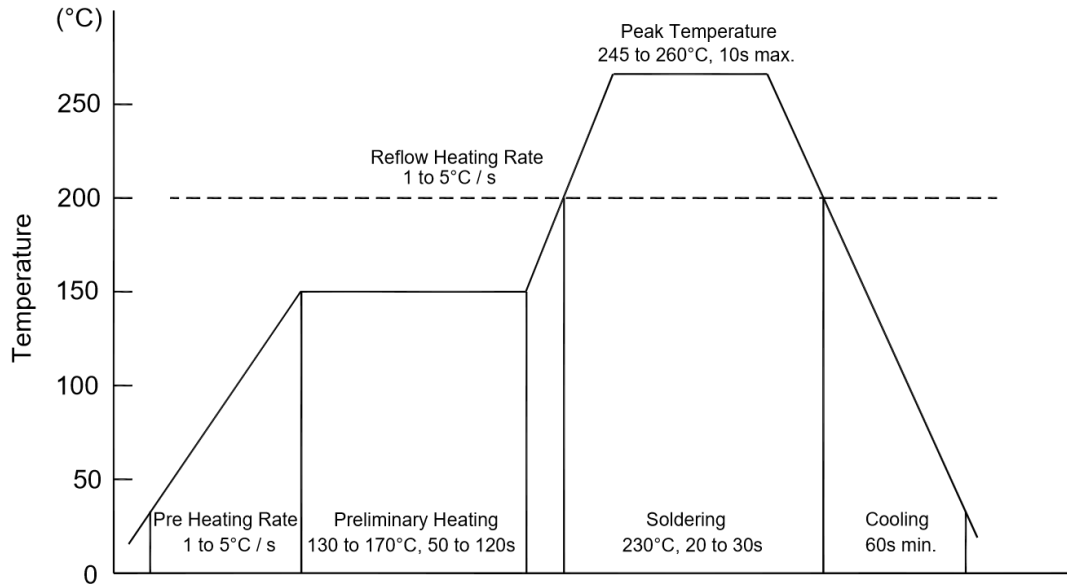

Recommended peak temperature is over 245°C. If peak temperature is below 245°C, you may adjust the following parameters:

- Time length of peak temperature (longer)
- Time length of soldering (longer)
- Thickness of solder paste (thicker)

◆ Conditions of hand soldering

- Temperature: 300°C
- Time: 3s max.
- Times: one time

◆ Storage conditions

- **Temperature**
5 to 40°C
- **Humidity**
30 to 80% RH
- **Recommended period**
One year after manufacturing

Package Specifications

- The method of packaging

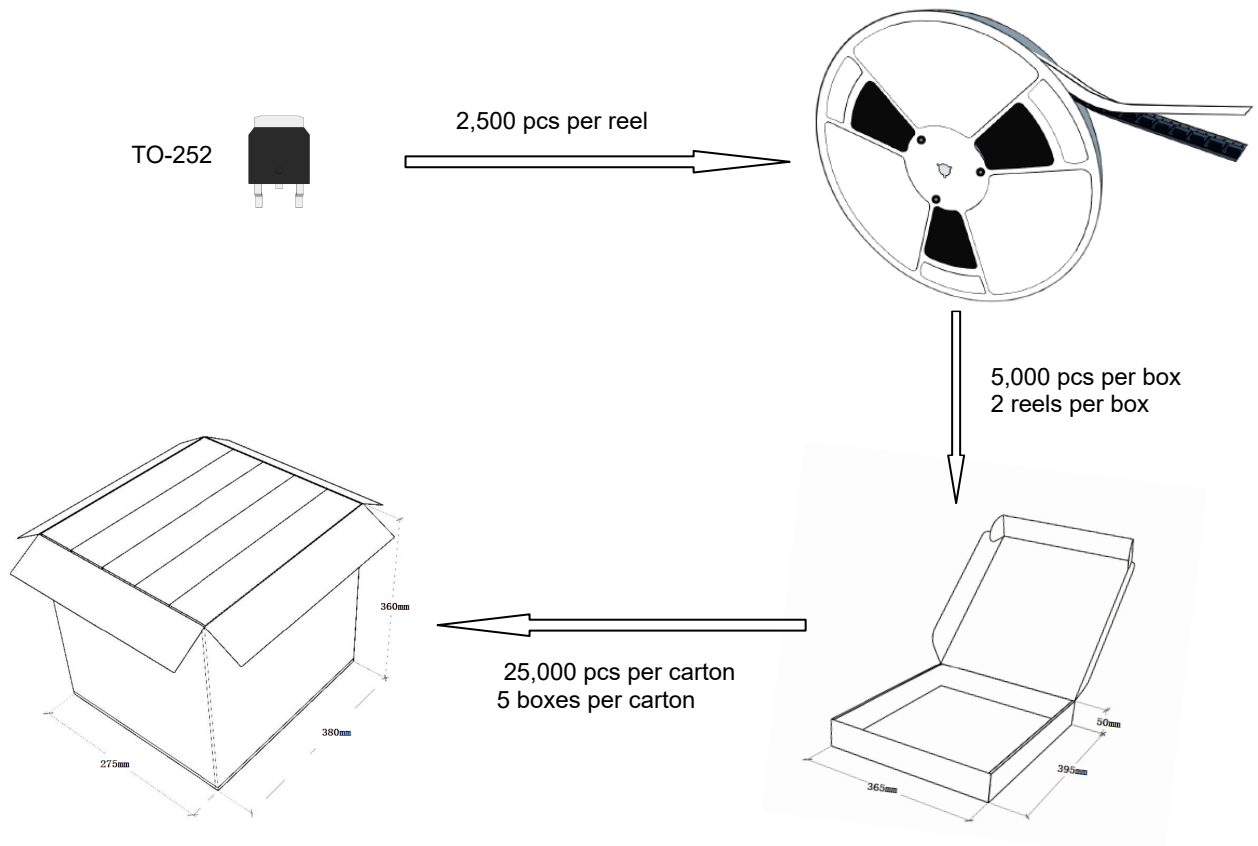

◆ reel data

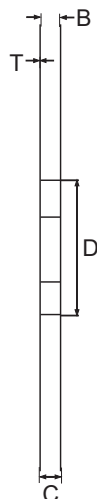
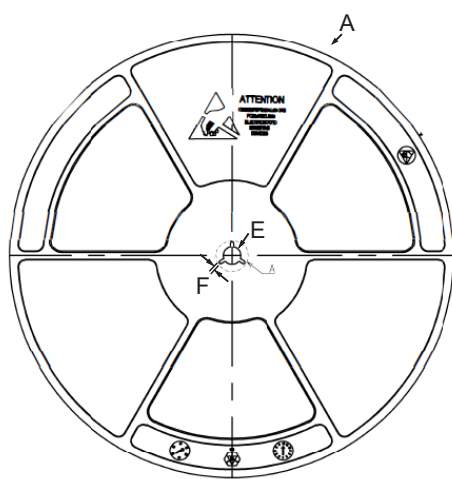

Symbol	Value(unit:mm)
A	$\Phi 330.2 \pm 1$
B	17 ± 0.5
C	21.2 ± 2
D	$\Phi 100 \pm 0.5$
E	$\Phi 13.4 \pm 0.2$
F	2.3 ± 0.2
T	2.1 ± 0.2



PJMG60P60TE

P-Channel Enhancement Mode Power MOSFET

◆ Embossed tape data

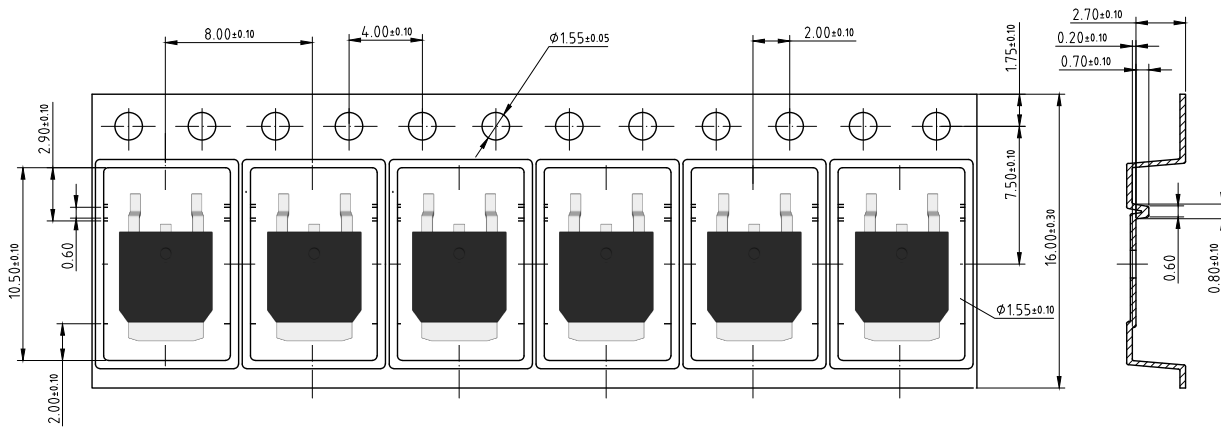

X-ON Electronics

Largest Supplier of Electrical and Electronic Components

Click to view similar products for [MOSFET](#) category:

Click to view products by [Pingjingsemi](#) manufacturer:

Other Similar products are found below :

[IRFD120](#) [IRFY240C](#) [JANTX2N5237](#) [2SK2267\(Q\)](#) [BUK455-60A/B](#) [MIC4420CM-TR](#) [VN1206L](#) [NDP4060](#) [SI4482DY](#)
[IPS70R2K0CEAKMA1](#) [SQD23N06-31L-GE3](#) [TK16J60W,S1VQ\(O](#) [2SK2614\(TE16L1,Q\)](#) [DMN1017UCP3-7](#) [EFC2J004NUZTDG](#)
[DMN1053UCP4-7](#) [SQJ469EP-T1-GE3](#) [NTE2384](#) [DMC2700UDMQ-7](#) [DMN2080UCB4-7](#) [DMN61D9UWQ-13](#) [US6M2GTR](#)
[DMN31D5UDJ-7](#) [DMP22D4UFO-7B](#) [DMN1006UCA6-7](#) [DMN16M9UCA6-7](#) [STF5N65M6](#) [IRF40H233XTMA1](#) [STU5N65M6](#)
[DMN6022SSD-13](#) [DMN13M9UCA6-7](#) [DMTH10H4M6SPS-13](#) [DMN2990UFB-7B](#) [IPB80P04P405ATMA2](#) [2N7002W-G](#) [MCAC30N06Y-](#)
[TP](#) [MCQ7328-TP](#) [NTMC083NP10M5L](#) [NVMFS2D3P04M8LT1G](#) [BXP7N65D](#) [BXP4N65F](#) [AOL1454G](#) [WMJ80N60C4](#) [BXP2N20L](#)
[BXP2N65D](#) [BXT1150N10J](#) [BXT1700P06M](#) [TSM60NB380CP](#) [ROG](#) [RQ7L055BGTCR](#) [DMNH15H110SK3-13](#)