

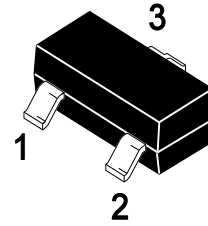

Features

- Low dynamic output impedance.
- Sink current capability of 1 to 100mA.
- Low output noise voltage
- Fast turn on response

SOT-23



Marking: TL432: 432G
TL432C: 432CG

Application

- It provides very wide applications, including shunt regulator, series regulator, switching regulator, voltage reference and others.

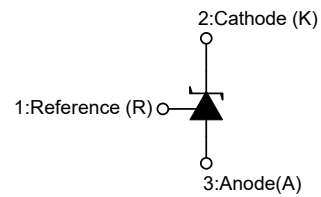

Absolute Maximum Ratings (Ta=25°C unless otherwise specified)

Symbol	Parameter	Rating	Units
V _{KA}	Cathode Voltage	20	V
I _{KA}	Cathode Current Range(Continuous)	-100 ~ +100	mA
I _{REF}	Reference Input Current Range	10	mA
P _D	Power Dissipation	350	mW
T _J	Operating Junction	+150	°C
T _{OPR}	Operating Ambient	0 ~ +70	°C
T _{STG}	Storage Temperature	-65 ~ +150	°C

Recommended Operating Conditions

Symbol	Parameter	Min.	Max.	Units
V _{KA}	Cathode Voltage	V _{REF}	18	V
I _{KA}	Cathode Current	0.1	100	mA



Electrical Characteristics (Ta=25°C unless otherwise specified)

Symbol	Parameter	Test Conditions	Min.	Typ.	Max.	Unit	
V _{REF}	Reference Input Voltage Fig 1	V _{KA} =V _{REF} , I _{KA} =10mA	TL432C	1.244	1.25	1.256	V
			TL432	1.24	1.25	1.26	V
ΔV _{REF}	Deviation of Reference Input Voltage Over Temperature Fig 1	V _{KA} =V _{REF} , I _{KA} =10mA, 0°C ≤ T _A ≤ 70°C		2	10	mV	
$\frac{\Delta V_{REF}}{\Delta V_{KA}}$	Ratio of Change in Reference Input Voltage to the Change in Cathode Voltage Fig 2	I _{KA} =10mA ΔV _{KA} =V _{REF} ~16V			2.4	mV/V	
I _{REF}	Reference Input Current	I _{KA} =10mA, R1=10kΩ, R2=∞		0.15	0.4	μA	
ΔI _{REF}	Deviation of Reference Input Current Over Full Temperature Range Fig 2	I _{KA} =10mA, R1=10kΩ, R2=∞, 0°C ≤ T _A ≤ 70°C			0.6	μA	
I _{KA(MIN)}	Minimum Cathode Current for Regulation Fig 1	V _{KA} =V _{REF}			100	μA	
I _{KA(OFF)}	Off-State Cathode Current Fig 3	V _{KA} =18V, V _{REF} =0		0.04	0.5	μA	
Z _{KA}	Dynamic Impedance	V _{KA} =V _{REF} , I _{KA} =1~100mA, f≤1.0kHz		0.15	0.5	Ω	

Figure 1. Test Circuit for V_{KA} = V_{ref}

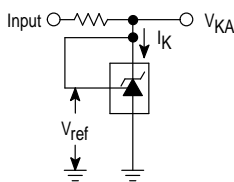

Figure 2. Test Circuit for V_{KA} > V_{ref}

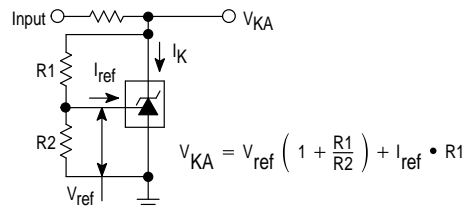
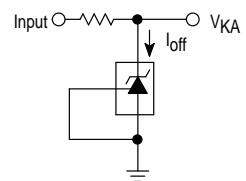
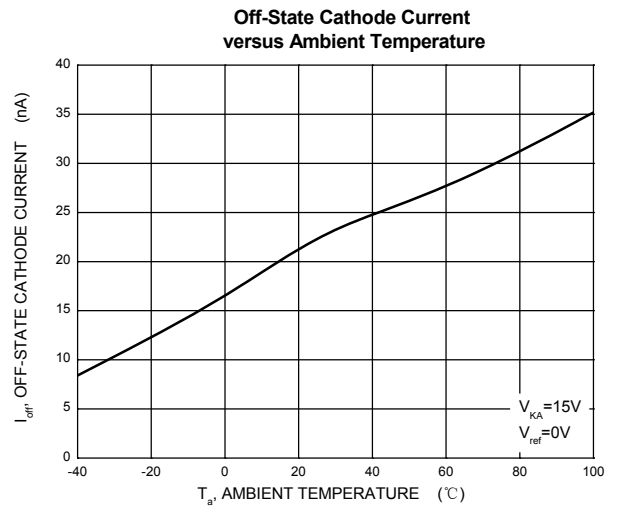
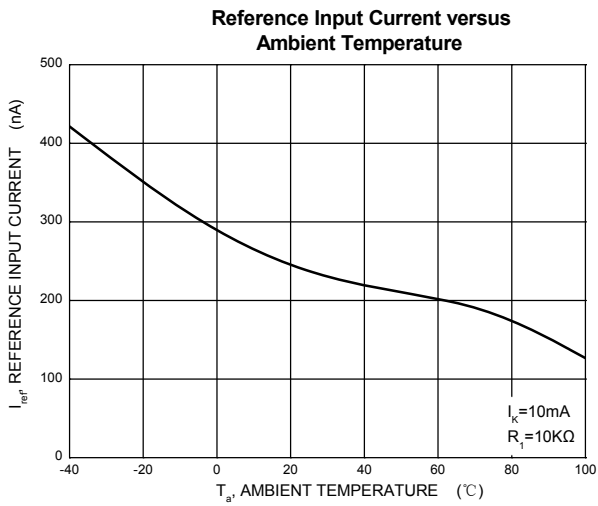
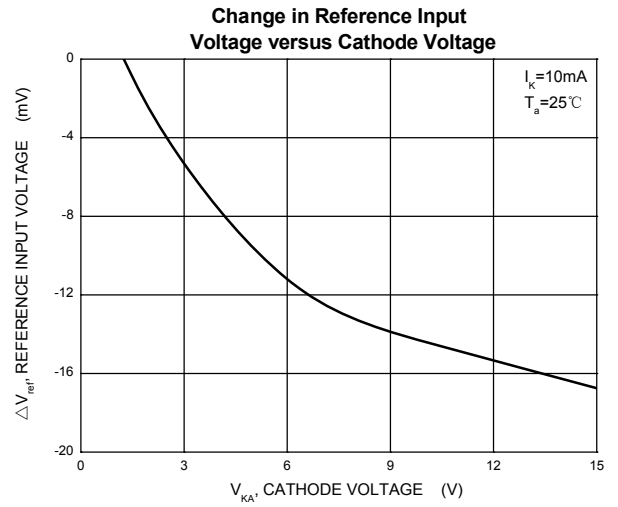
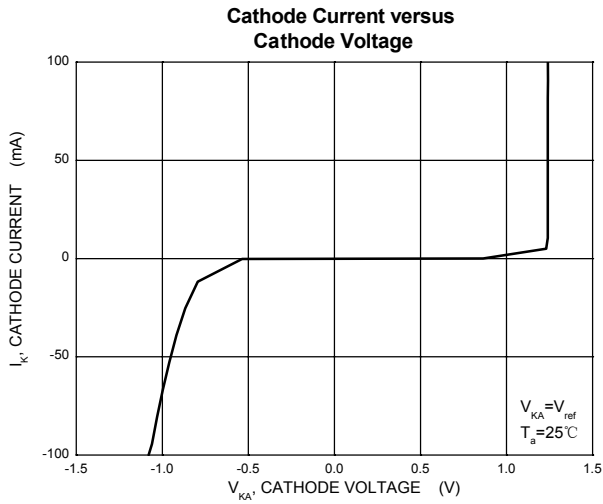

Figure 3. Test Circuit for I_{off}





Typical Characteristic Curves





Package Outline
SOT-23

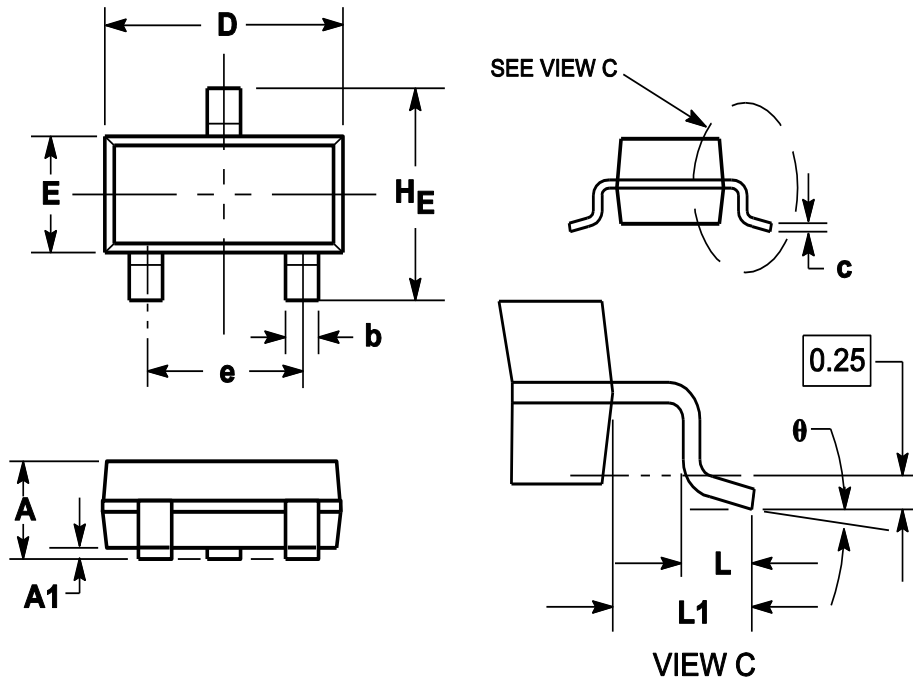

Symbol	Dimensions in millimeter		
	Min.	Typ.	Max.
A	0.900	1.025	1.150
A1	0.000	0.050	0.100
b	0.300	0.400	0.500
c	0.080	0.115	0.150
D	2.800	2.900	3.000
E	1.200	1.300	1.400
HE	2.250	2.400	2.550
e	1.800	1.900	2.000
L1	0.550REF		
L	0.300		0.500
θ	0°		8°

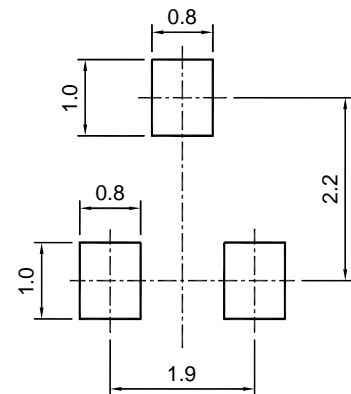

SOT-23 (TO-236)
Recommended soldering pad

Ordering Information

Device	Package	Shipping
TL432/TL432C	SOT-23	3000PCS/Reel&Tape

X-ON Electronics

Largest Supplier of Electrical and Electronic Components

Click to view similar products for [Voltage References](#) category:

Click to view products by [Pingjingsemi](#) manufacturer:

Other Similar products are found below :

[622664A](#) [636116E](#) [748389C](#) [AS431ARTR-E1](#) [NCP431BCSNT1G](#) [NCP432BCSNT1G](#) [NCV431BSNT1G](#) [AP4313UKTR-G1](#)
[TL1431AIYDT](#) [AZ431BR-ATRE1](#) [622668D](#) [NCP432BVSNT1G](#) [5962-8686103XC](#) [NCV431BVDMR2G](#) [AZ432BNTR-G1](#)
[AP4306BUKTR-G1](#) [SC431BVSNT1G](#) [MAX6023EBT30+T](#) [NCV431ASNT1G](#) [LM4040CEM3-5.0/V+T](#) [LT1460KCS3-3#TRM](#)
[LT1460KCS3-3.3#TRM](#) [LT1019AIS8-2.5](#) [LT6660KCDC-10#TRMPBF](#) [LTC6652BHLS8-5#PBF](#) [LTC6652AHLS8-4.096#PBF](#)
[LTC6655BHLS8-4.096#PBF](#) [LT6660HCDC-5#TRMPBF](#) [LM336Z-2.5#PBF](#) [LT1021BMH-10](#) [SC431ILPRAG](#) [TLVH431MIL3T](#)
[MAX6023EBT21+T](#) [AP432AQG-7](#) [ADR4540CRZ](#) [LM4040B25QFTA](#) [TS3325AQPR](#) [REF102AU/2K5](#) [TL4050B25QDBZR](#)
[TL4051C12QDCKR](#) [TL431ACZ](#) [KA431SLMF2TF](#) [KA431SMF2TF](#) [KA431SMFTF](#) [LM385BXZ/NOPB](#) [LM4040QCEM3-3.0/NOPB](#)
[LM4041C12ILPR](#) [LM4050AEM3X-5.0/NOPB](#) [LM4050AIM3X-5.0/NOPB](#) [LM4120AIM5-2.5/NOP](#)