

# BG1B – Universal Gate Drive Prototype Board

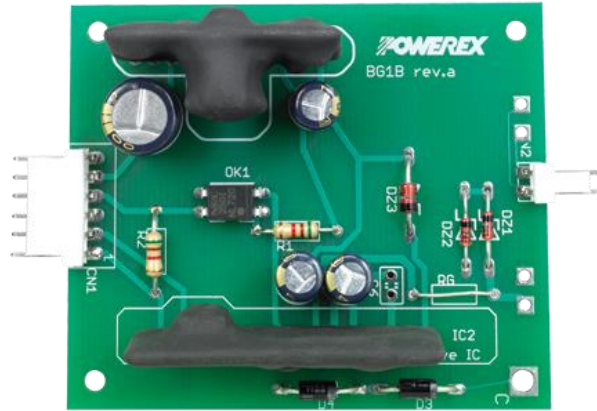

## Description:

The BG1B is a single channel gate drive circuit board for high power IGBT modules. The BG1B utilizes Powerex hybrid gate drivers and DC-to-DC converters to provide efficient switching of single or chopper modules rated up to 400A/1200V. The hybrid gate drivers include high-speed opto-couplers for control signal isolation and desaturation detection to protect the IGBT from short circuit conditions. The hybrid DC-to-DC converters provide fully isolated control power for each driving channel. The BG1B also provides an isolated fault feedback signal.

## Features:

- 3A or 5A Peak Output Current
- 2500VRMS isolation for control power and signals
- Uses Standard AMP MTA .100" input connector
- Operates from a single 15 VDC or 24 VDC supply
- Wide output voltage swing +15V/-8V
- Compact Size 2.6" x 2.1" (65mm x 54mm)

## Applications:

The BG1B can be used for driving single or chopper IGBT modules and was designed specifically to provide a direct mounting option for the following small NX package devices: CM150EX-24S, CM200EX-24S and CM300EX-24S.

- Use **VLA106-15242** DC to DC converter for operation with 15 VDC control power
- Use **VLA106-24242** DC to DC converter for operation with 24 VDC control power

**Ordering Information:** **BG1B-3015** is a kit with a bare BG1B board, one VLA541-01R and one VLA106-15242  
**BG1B-5015** is a kit with a bare BG1B board, one VLA542-01R and one VLA106-15242

## BG1B Application Guide

Gate Driver Part Number	Peak Drive Current (I <sub>OP</sub> )	Minimum R <sub>G</sub>	Typical Application* (IGBT Module Rating)	DC-to-DC Converter
VLA541-01R	±3A	3.0Ω	Up to 200A	VLA106-15242 for 15 VDC input VLA106-24242 for 24 VDC input
VLA542-01R	±5A	2.0Ω	Up to 400A	

\*Compatible IGBT depends on voltage rating, switching frequency and selected R<sub>G</sub>. Refer to Powerex application for details.

### Circuit Explanation:

The BG1B is a basic single channel gate driver designed around the recommended application circuits for the Powerex VLA541-01R and VLA542-01R hybrid IGBT gate drivers in combination with either VLA106-15242 or VLA106-24242 isolated DC-to-DC converters.

A functional block diagram of the VLA541-01R/VLA542-01R and hybrid gate drivers is shown for reference in Figure 1. These gate drivers are optimized for use with Powerex IGBT modules. The drivers use a high speed open collector type opto-coupler to provide 2500VRMS isolation of control signals. The output stage is designed to provide high current gate drive with the appropriate on- and off-state bias voltages for large IGBT modules. The gate driver includes a desaturation detection circuit to provide protection against short circuit conditions. For additional detailed information on the characteristics and operation of these gate drivers please refer to the individual device datasheets.

Figure 2 shows a block diagram of the VLA106-15242 and VLA106-24242 hybrid DC-to-DC converters. These two devices are identical except that VLA106-15242 is designed to operate from a 15 VDC input and the VLA106-24242 is designed to operate from a 24 VDC input. These DC-to-DC converters use a transformer to provide 2500VRMS isolation for gate drive power. The converter's regulated 24 VDC output is split using a resistor and zener diode to provide +15.8V and -8.2V for the hybrid gate driver. For additional detailed information on the operation of the hybrid gate drivers and DC-to-DC converters please see the individual device datasheets.

A complete schematic and component selection guide for the BG1B is shown in Figure 3. The board will normally be operated with two input voltage sources. A 5V logic source (+V<sub>L</sub>) provides drive for the high speed opto-couplers inside the hybrid gate drivers and pull-up voltage for the fault signal isolation optos OP1 and OP2. A control power supply (+V<sub>S</sub>) provides power for the gate driver and is connected to the primary side of the DC-to-DC converters at Pins 8, 9 and 10, 11. The +V<sub>S</sub> source is decoupled with the low impedance electrolytic capacitors C4 and C8. These capacitors are connected close to the input pins of each DC-to-DC converter to provide a stable, well-filtered DC source. A 150μF capacitor was selected for C4 and C8 to provide the required ripple current and filtering assuming a maximum driving load and a significant distance to the main filter capacitor of the +V<sub>S</sub> supply. These capacitors will be larger than necessary if the driving load is smaller or the V<sub>S</sub> supply main filter capacitors are nearby. The DC-to-DC converters provide isolated gate drive power which consists of +15.8V (V<sub>CC</sub>) at Pin 3 and -8.2V (V<sub>EE</sub>) at Pin 1 with respect to common at Pin 2. The gate drive power supplies are decoupled using the low impedance electrolytic capacitors C1, C2, C5, and C6. It is very important that these capacitors have low enough impedance and sufficient ripple current capability to provide the required high current gate drive pulses. The 82μF low impedance capacitors used on the BG1B are sized to supply 5A gate pulses at a 10 kHz rate. If the application is operating at lower frequency or lower peak current it may be possible to reduce the size of these capacitors.

The isolated V<sub>EE</sub> and V<sub>CC</sub> supplies provided by the DC-to-DC converters are connected to the hybrid gate drivers at Pins 4 and 6 to provide gate drive power. The hybrid gate driver amplifies the control input signal and produces high current gate drive at Pin 5. The gate drive current is adjusted by selecting the appropriate series gate resistance (R<sub>G</sub>). R<sub>G</sub> will normally be adjusted to provide suitable drive for the module being used considering dynamic performance, losses and switching noise. For more information on selecting R<sub>G</sub> see Powerex IGBT module application notes. Protection against gate voltage surges is provided by DZ1 and DZ2. These zener diodes also help to control short circuit currents by shunting miller current away from the gate.

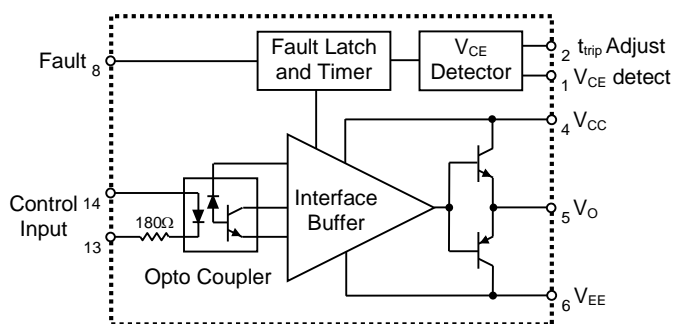

**Figure 1: VLA541-01R/VLA542-01R Block Diagram**

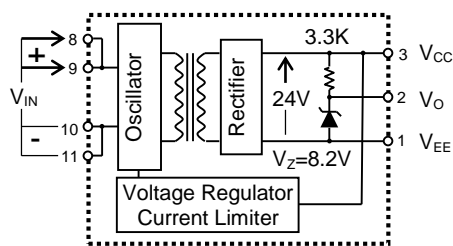

**Figure 2: VLA106-15242, VLA106-24242 Block Diagram**

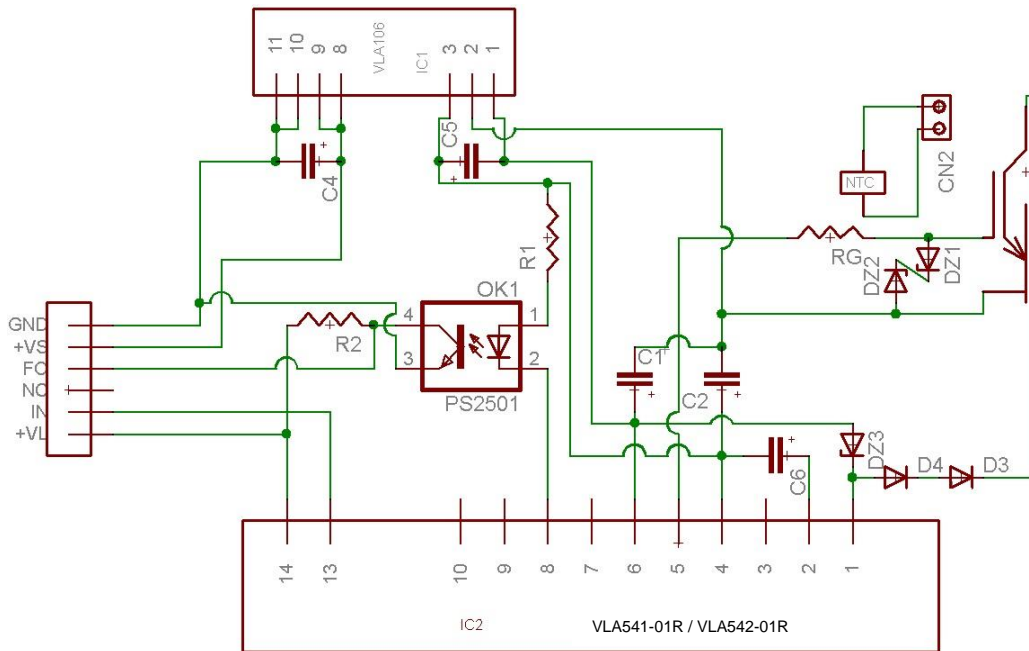

**Component Selection:**

Designation	Typical Value	Description	Example: Mfg./PN
D1, D2	0.5 A, 1000V	V <sub>CE</sub> detection diode – ultra fast recovery	ON Semi MUR1100E
DZ1, DZ2	16V, 1W	Gate Voltage Surge Protection	1N4745
DZ3	30V, 1W	Detect input pin surge voltage protection	1N4751
C4	100µF, 35V	Power supply filter – electrolytic, low Impedance	Panasonic EEU-FC1V820
C1, C2, C5	47µF, 35V	Control power filter – electrolytic, low impedance	Panasonic EEU-FC1V151
C6*	0-200 pF	Adj. Trip time – multilayer ceramic or film*	EPCOS B37979-----
R1	4.7kΩ, 0.25W	Fault sink current limiting resistor	
R2	4.7KΩ, 0.25W	Fault feedback pull-up resistor	
OK1	NEC PS2501	Opto-coupler for fault signal isolation	NEC PS2501
CN1**	MTA .100"	Input and gate drive connectors	AMP 640457-6
CN2	MTA .100"	Thermistor connector	AMP 640457-2

\* Not required in all applications. Please see hybrid gate driver application notes for details.  
 \*\* Recommended mating connector AMP CST-100 Housing P/N 770602-6 with crimp contact 770666-2.

**Figure 3: BG1B Schematic and Component Selection**

Short circuit protection is provided by means of desaturation detection. For details on the operation of this circuit consult the hybrid gate driver individual data sheets. The collector voltage of the IGBT is detected through the series connected high voltage blocking diodes D1 and D2. The combined blocking voltage of the series connected diodes must be equal to or greater than the V<sub>CES</sub> rating of the IGBT. For applications using lower voltage IGBT modules it is possible to use a single detection diode in each channel. DZ3 protects the gate driver’s detect input (Pin 1) from voltage surges during reverse recovery of the high voltage blocking diodes. Capacitors C6 is used to adjust the driver’s protection circuit trip time. The driver’s default settings are sufficient for many applications so it may be possible to omit these capacitors. For details on the use of C6 consult the individual gate driver datasheet.

If the gate driver’s short circuit protection is activated it immediately shuts down the gate drive and pulls Pin 8 low to indicate a fault. Current flows from Vcc (Pin 3 of DC-to-DC converter) through the LED in fault isolation opto (OK1). The transistor in the fault isolation opto turns on and pulls the fault signal line (FO) at Pin 4 of CN1 low. This opto isolated signal can now be used by the controller to detect the fault condition.

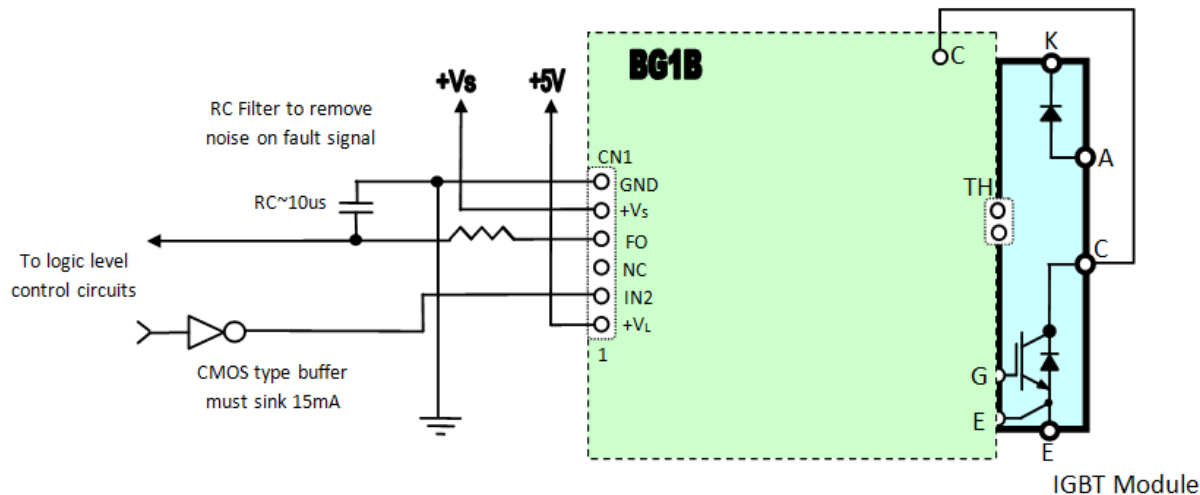

**Figure 4: BG1B External Wiring Diagram**

**Interface Circuit Requirements:**

A typical interface circuit for the BG1B is shown in Figure 4. A single control power supply (+Vs) is connected to Pin 5 of CN1 with its common at Pin 6. This supply provides all of the gate drive power for both channels via the hybrid DC-to-DC converters. The current drawn from the +Vs supply will vary from less than 100mA to more than 500mA depending on the switching frequency and size of IGBT being driven. Consult the hybrid gate driver application notes for details on determining the required supply current for the gate driver. The gate driver supply current can then be converted into current drawn from the +Vs supply using the efficiency specification on the DC-to-DC converter data sheet.

A 5V logic supply is connected at Pin 1 of CN1, with its common at Pin 6, which is shared with the 15V control supply. The 5V supply is directly connected to Pin 14 of the hybrid gate driver which is internally connected to the anode of the LED in the high speed opto-coupler. The 5V supply is also used to pull the output side of the fault isolation opto-couplers high.

The control signal interface is designed for use with standard 5V CMOS logic. The control input signal at Pin 2 of connector CN1 is used to turn the IGBT on and off. These signals are active low which means that the gate driver output will be high (IGBT ON) when they are pulled low. These control pins are connected directly to Pin 13 of the hybrid gate driver which is connected internally through a 180Ω limiting resistor to the cathode of the LED in the high speed opto-coupler (Figure 1). When the control signal is pulled low, current flows from the 5V logic supply through the LED to turn the gate driver's output on. The control pins must be pulled low with a buffer that is capable of sinking at least 16mA in order to turn on the high speed opto coupler inside the hybrid gate driver. A CMOS buffer that actively pulls its output high in the off state (74HC04 or similar) is recommended for maintaining good common mode noise immunity. Open collector drive that allows IN1 to float will degrade common mode noise immunity and is therefore not recommended.

The fault signal line on pin 4 of CN1 is active low which means that a fault condition will be indicated by a low level signal. During normal operation Pin 4 is pulled high to the +Vl supply by the 4.7kΩ resistor R2. If either of the hybrid gate drivers detects a short circuit condition its fault isolation opto (OK1) will turn on and pull Pin 4 of CN1 low. When a fault is detected the hybrid gate drivers disable the output and produce a fault signal for a minimum of 1ms. Any signal on the fault line that is significantly shorter than 1ms cannot be a legitimate fault so it should be ignored. Therefore, for a robust noise immune design, it is recommended that an RC filter with a time constant of approximately 10µs be added between Pin 4 and the controller as shown in Figure 4.

**Printed Circuit Layout:**

Figure 5 shows the layout of the BG1B two channel gate driver board. The compact 2.6" x 2.1" circuit board with only 18 components clearly demonstrates the advantage of using hybrid gate drivers and DC-to-DC converters. One important feature is the use of separate ground planes for the regions of the PCB having high voltage differences. One ground plane is tied to the IGBT emitter/circuit common (Pin 2 of the DC-to-DC converter) of the output. The other is connected to logic interface common at Pin 6 of CN1. This layout provides shielding to help prevent undesirable coupling of noise between the control side and the gate drive channels.

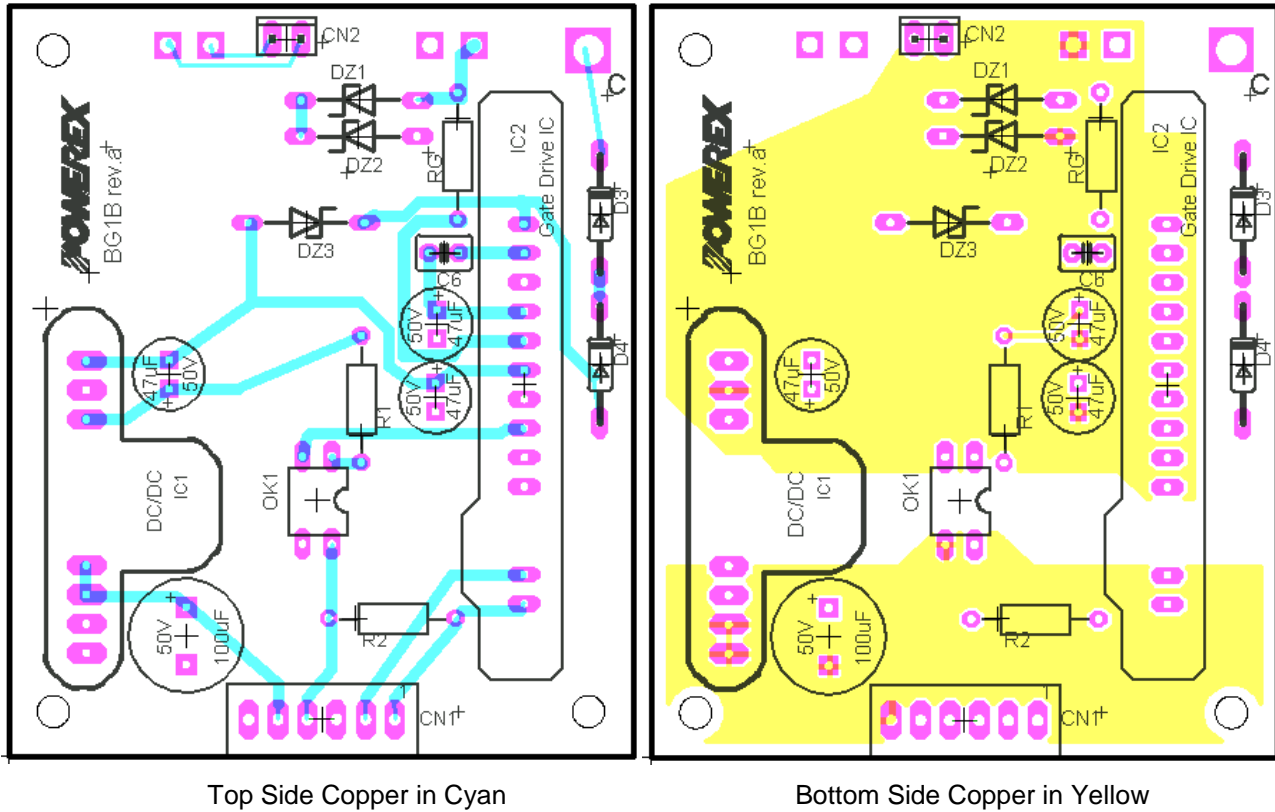

**Figure 5: BG1B Printed Circuit Board Layout**

**Additional Information:**

Detailed information about the operation and electrical characteristics of the VLA542-01R and VLA541-01R hybrid gate drivers can be found on the individual device data sheets. Electrical characteristics such as input voltage range, efficiency, and output voltage regulation of the VLA106-15242 and VLA106-24242 DC-to-DC converters can also be found on the individual device data sheets. Information about calculating gate drive current and selection of series gate resistors ( $R_G$ ) can be found in the general IGBT module and gate drive application notes. For applications using higher current IGBT modules refer to the application notes for the VLA500-01 hybrid gate driver and BG2A reference design. For applications using high frequency optimized IGBT modules refer to the VLA502-01 application note. All of these documents are available on the Powerex website at [www.pwr.com](http://www.pwr.com). For design assistance with any of the products covered in this application note contact your local Powerex representative or Powerex application engineering at (724) 925-7272, option 3.

## **X-ON Electronics**

Largest Supplier of Electrical and Electronic Components

*Click to view similar products for [powerex manufacturer](#):*

Other Similar products are found below :

[R7013003XXUA](#) [R9G01212XX](#) [VLA541-01R](#) [QRD0630T30](#) [CM400DY-24NF](#) [CM100TX-24S1](#) [CM600HA-24A](#) [NLD422PB](#)  
[PSM03S93E5-A](#) [BP2B-V](#) [ND431625](#) [R5031213LSWS](#) [BG2B](#) [BG2C-5015](#) [ND431825](#) [T9G0121203DH](#) [CD611616C](#) [BG1A-PX](#)  
[TCS4402802DH](#) [CD421690C](#) [PM600DVA060](#) [CD411899C](#) [CD631615B](#) [C601PB](#) [R5021213LSWS](#) [BG2A-NFH](#) [C180PB](#) [CD431690B](#)  
[NLR425CM](#) [HARDWARE KIT 50](#) [CD410899C](#) [CM400HA-24A](#) [CD411699C](#) [LEAD KIT #NK](#) [HARDWARE KIT 49](#) [VLA500-01](#)  
[HARDWARE KIT 87](#) [VLA502-01](#) [VLA106-24154](#) [VLA106-15242](#)