

2SD106AI-17 UL Dual SCALE Driver Core for IGBTs and Power MOSFETs

Description

The SCALE drivers from CONCEPT are based on a chip set that was developed specifically for the reliable driving and safe operation of IGBTs and power MOSFETs.

The name "SCALE" is an acronym for the most outstanding properties of the SCALE series of drivers:

SCALE = Scaleable, Compact, All purpose, Low cost and Easy to use.

The SCALE driver is a winning project of the competition organized by "Technology Center Switzerland 1998". And ABB Switzerland AG honored the development of the SCALE driver by distinguishing it as the "best power electronics project in 1998".



Product Highlights

- ✓ Suitable for IGBTs and power MOSFETs
- ✓ Short circuit and overcurrent protection
- ✓ Extremely reliable, long service life
- ✓ High gate current of $\pm 6A$
- ✓ Electrical isolation of $4000V_{AC}$
- ✓ Electrically isolated status acknowledgement
- ✓ Monitoring of power supply and self-monitoring
- ✓ Switching frequency DC to $>100kHz$
- ✓ Duty cycle: 0... 100%
- ✓ High dv/dt immunity, guaranteed $>100,000V/\mu s$
- ✓ Complete with DC/DC converter
- ✓ UL compliant

Applications

- ✓ Inverters
- ✓ Motor drive technology
- ✓ Traction
- ✓ Railroad power supplies
- ✓ Converters
- ✓ Power engineering
- ✓ Switched-mode power supplies
- ✓ Radiology and laser technology
- ✓ DC/DC converter
- ✓ Research
- ✓ RF generators and converters

Block Diagram

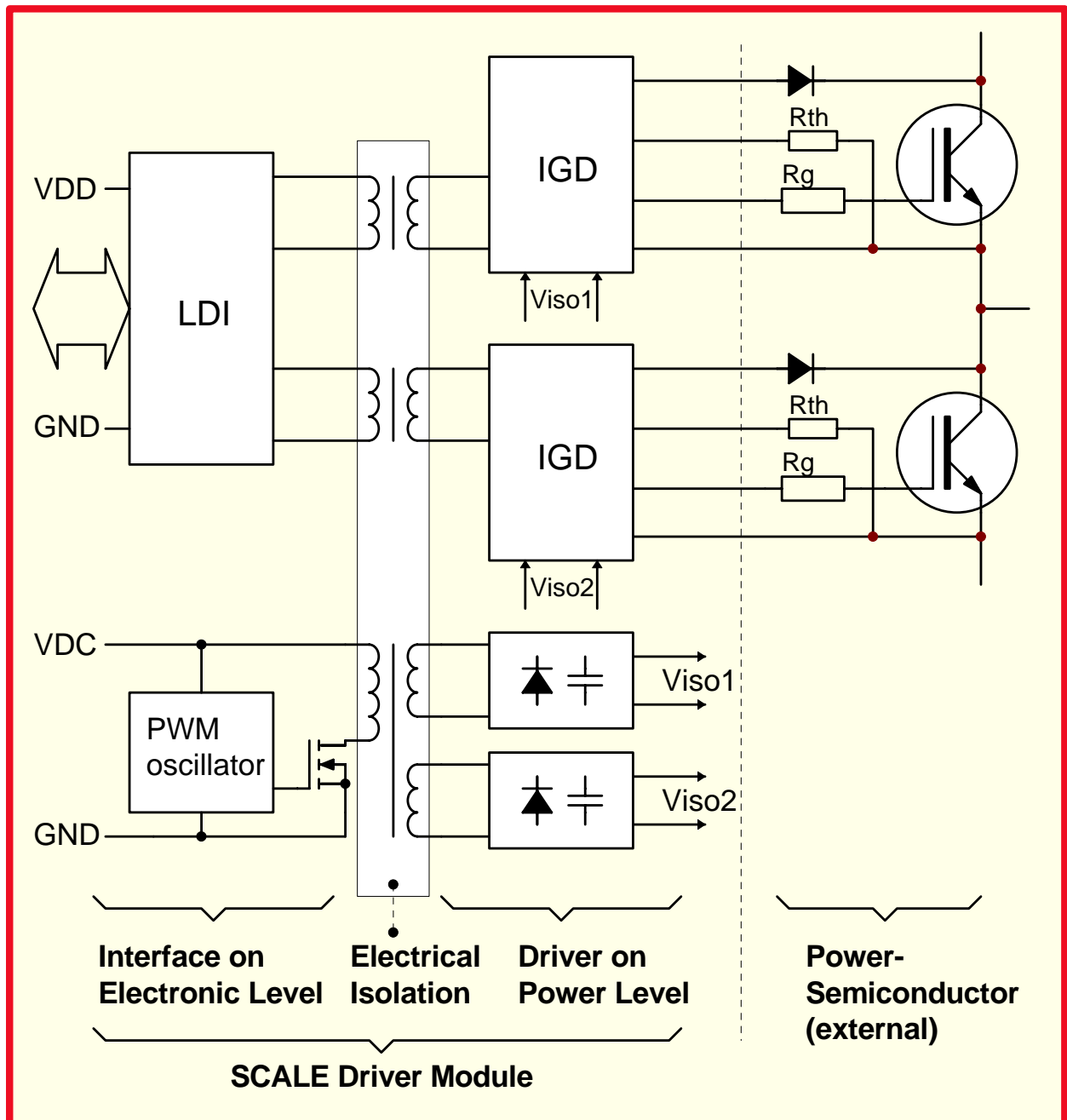

Fig. 1 Block diagram of the 2SD106AI-17 UL

Pin Designation

Pin	Des.	Function	Pin	Des.	Function
1	VDD	+15V for electronic input side	24		Free
2	GND	GND for electronic input side	23	C1	Collector sense channel 1
3	SO1	Status output channel 1	22	Rth1	Reference resistor channel 1
4	VL	Logic level/Reset	21	E1	Emitter channel 1
5	RC1	RC network deadtime channel 1	20	G1	Gate channel 1
6	InA	Input A	19		Free
7	InB	Input B	18		Free
8	RC2	RC network deadtime channel 2	17	C2	Collector sense channel 2
9	MOD	Mode input	16	Rth2	Reference resistor channel 2
10	SO2	Status output channel 2	15	E2	Emitter channel 2
11	GND(dc)	Ground of the DC/DC converter	14	G2	Gate channel 2
12	VDC	+15V for DC/DC converter	13		Free

Legend:

Pins with the designation "Free" are not physically present (drawn as "X" in Fig. 3 bottom).

Mechanical Dimensions

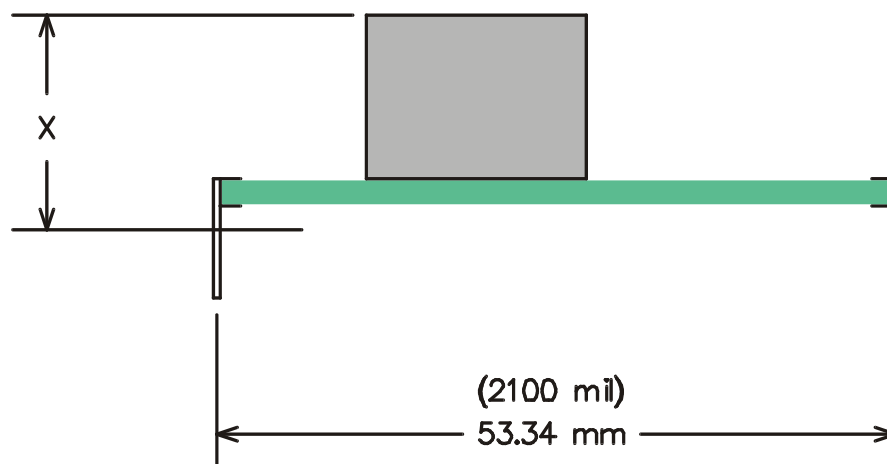

Fig. 2 Side view 2SD106AI-17 UL

Height X: typ. 16mm

2SD106AI-17 UL Data Sheet

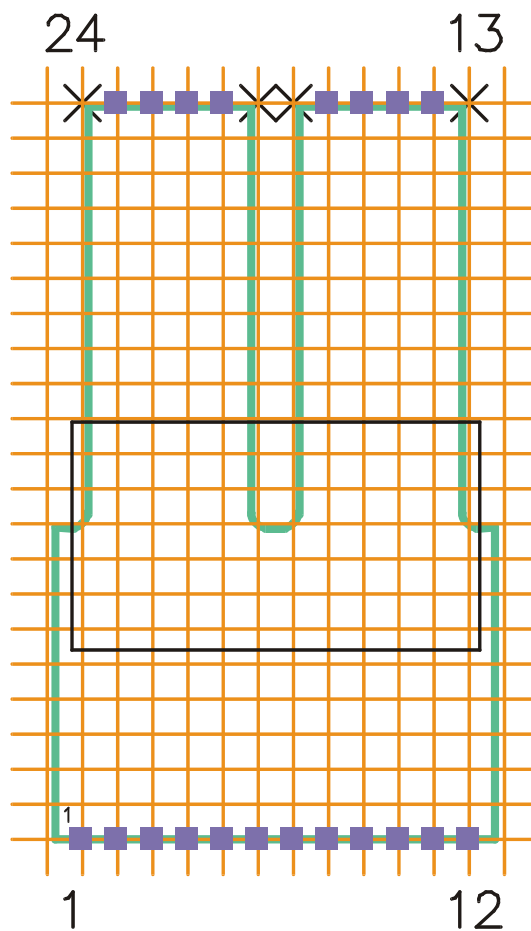
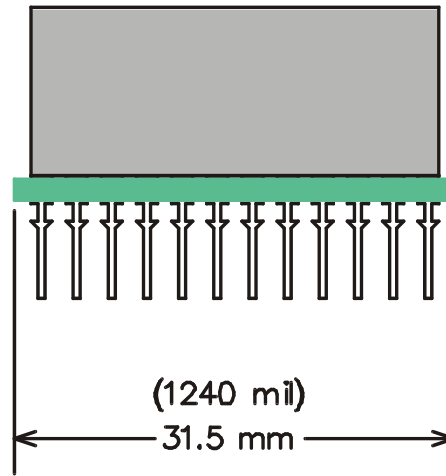

Fig. 3 Front view (top) / Layout overview component side (bottom) 2SD106AI-17 UL

Details of the circuit board layout

Grid of the aspect drawing on page 4 below: 2.54mm (100mil)

Recommended diameter of solder pad: Ø 1.6mm

Recommended diameter of drill holes: Ø 1.0mm

Absolute Maximum Ratings

Parameter	Test conditions	min	max	unit
Supply voltage <i>VDC</i>		0	16	Vdc
Supply voltage <i>VDD</i>		0	16	Vdc
Logic input voltage	to GND	0	<i>VDD</i>	Vdc
Gate peak current <i>I_{out}</i>	Gx to Ex	-6	+6	A
Output power DC/DC converter	total for both channels		2	W
Test voltage (50Hz/1min)	inputs to outputs		4000	V _{AC(eff)}
Operating voltage	continuous (see Note 8)		1200	Vdc
Operating temperature	(see Note 10)	-40	+85	°C
Storage temperature		-40	+90	°C

All data refer to +25°C and *VDD* = *VDC* = 15V unless otherwise specified

Electrical Characteristics

Power supply	Test conditions	min	typ	max	unit
Nominal supply voltage <i>VDC</i>	to GND (see Note 1)	15			Vdc
Supply current <i>IDC</i>	without load	23			mA
Max. supply current <i>IDC</i>	(see Note 2)			153	mA
Output power DC/DC converter	(see Note 3)			2	W
Efficiency η	internal DC/DC converter	85			%
Nominal supply voltage <i>VDD</i>	to GND	15			Vdc
Supply current <i>IDD</i>	without load	12			mA
Supply current <i>IDD</i>	at 25kHz switching frequency	15			mA

2SD106AI-17 UL Data Sheet

Electrical Characteristics (Continuation)
--

Power supply monitoring	Test conditions	min	typ	max	unit
Turn-on threshold V_{th}	(see Note 4)		11.5		Vdc
Hysteresis on-/off	(see Note 4)		0.7		Vdc
Logic inputs	Test conditions	min	typ	max	unit
Input voltage	all inputs (see Note 5)	0		VDD	Vdc
Timing characteristics	Test conditions	min	typ	max	unit
Delay time input to output	turn-on $t_{pd(on)}$		300		ns
	turn-off $t_{pd(off)}$		350		ns
Blocking time	after failure (see Note 12)		1		s
Outputs	Test conditions	min	typ	max	unit
Output current IG	Gx to Ex (see Note 6)	-6		+6	A
Output rise time $t_{r(out)}$	Gx to Ex (see Note 7)		100		ns
Output fall time $t_{f(out)}$	Gx to Ex (see Note 7)		80		ns
Output current SOx		1.5			mA
Output voltage rating SOx	SOx to GND			VDD	V
Vce-Monitoring	Test conditions	min	typ	max	unit
Inputs Cx	to Ex	0		VDD	Vdc
Electrical isolation	Test conditions	min	typ	max	unit
Operating voltage	continuous (see Note 8)			1200	Vdc
Test voltage	(50Hz/1min) (see Note 11)			4000	$V_{AC(eff)}$
Partial discharge extinction volt. IEC270				>1700	$V_{AC(pk)}$
Creep path input-output			12.7		mm
Creep path output-output			12.7		mm
Maximum $\Delta V/\Delta t$ at $\Delta V = 1000V$ (see Note 9)		100			kV/ μs

All data refer to +25°C and **VDD** = **VDC** = 15V unless otherwise specified

Operating Conditions

Operating conditions	Test conditions	min	max	unit
Operating temperature	(see Note 10)	-40	+85	°C
Storage temperature		-40	+90	°C

Footnotes to the key data

- 1) The drivers have a zener diode on each channel for over-voltage protection. When the feed voltage exceeds 16V, this protection can be subject to thermal overload.
- 2) If the specified power consumption is exceeded, this indicates an overload of the DC/DC converter. It should be noted that these DC/DC converters are not protected against overload.
- 3) This should be considered as a recommended value. Please consult the section: "Output power and self-heating".
- 4) Under-voltage monitoring for protecting the power semiconductors. The voltage refers to the local supply voltage of each individual drive channel. However, this corresponds approximately to the voltage at VDC with respect to GND.
- 5) The input levels must never exceed the limits of the supply voltage (i.e. between GND and VDD), otherwise latch-up of the integrated circuits LDI 00I can occur. Particular care must be taken when driving via cables or longer leads.
- 6) The gate current must be limited to its maximum value by a gate resistor.
- 7) At a load of 39nF in series with 5.6 Ω (typical load of a 1200V/100A IGBT).
- 8) Maximum continuous or repeatedly-applied DC voltage between all inputs and all outputs.
- 9) This specification guarantees that the drive information will be transferred reliably even at a high DC-link voltage and fastest switching operations.
- 10) The application-specific self-heating of the drivers - specially at high load - must be taken into account.
- 11) The test voltage of 4000 Vac(rms)/50Hz may be applied only once during a minute. It should be noted that with this (strictly speaking obsolete) test method, some (minor) damage occurs to the isolation layers due to the partial discharge. Consequently, this test is not performed at CONCEPT as a series test. In the case of repeated isolation tests (e.g. module test, equipment test, system test) the subsequent tests should be performed with a lower test voltage: the test voltage is reduced by 400V for each additional test. The more modern if more elaborate partial-discharge measurement is better suited than such test methods as it is almost entirely non-destructive.
- 12) The typical blocking time after an error is 1 second. If required, versions with other blocking times may also be supplied.

2SD106AI-17 UL Data Sheet

Application Hints

IMPORTANT INFORMATION

This data sheet contains only product-specific data. All data that apply to the whole type series of SCALE drivers is given in the document entitled: "Description and Application Manual for SCALE Drivers". In particular, this manual contains a detailed description of the concept of the SCALE drivers, a description of the function of all terminal pins as well as other important application hints.

Overview and application

The SCALE driver 2SD106AI-17 UL is a two channel-driver for power MOSFETs and IGBTs.

Its compact mechanical dimensions and simple electrical interface make this driver suitable for almost all conceivable applications. When used as a half-bridge driver, the 2SD106AI-17 UL can directly generate any dead times that may be required.

Output power and self-heating

The specified output power of the driver totals 2W (1W per channel). This typically suffices to drive a 100A/1200V six-pack IGBT module with 25kHz. In the case of a drive power of 2W, the typical input power of the driver is about 2.33W; the losses due to the driver total about 0.33W. Because CONCEPT cannot predict how the drivers will be incorporated in the user's application, no binding recommended value for self-heating and thus for the maximum useful output power at high ambient temperatures can be made. It is consequently recommended to check the self-heating of the system, especially when it is used at higher temperatures.

For the calculation of the exact output power, reference should be made to Application Note AN-9701 "IGBT drivers correctly calculated" on www.igbt-driver.com/go/app-note.

Collector sense and dimensioning of Rth

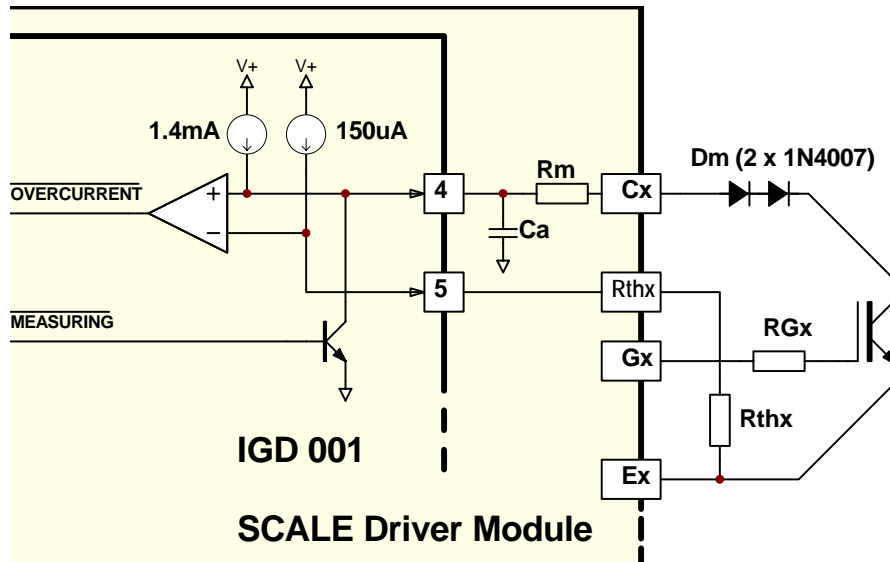

Fig. 4 Collector-sense circuit principle

The 2SD106AI-17 UL dual driver has a collector-sense circuit to protect the power semiconductors. It is shown in Fig. 4

Its basic operating mode can be obtained from the brochure entitled: "Description and Application Manual for Scale Drivers".

To correspond more effectively to the turn-on characteristic of the IGBTs, the

SCALE drivers do not use a static reference voltage to compare the voltage at the collector. Instead, the reference is used as shown in Fig. 5.

Value Rth	Reaction time	Vth1	Vth2	V _{CE(off)}
22k	≈ 4.9μs	≈ 4.8V	≈ 3.2V	2.35V (1 Diode)
27k	≈ 5.7μs	≈ 5.6V	≈ 3.9V	3.05V (1 Diode)
33k	≈ 6.8μs	≈ 6.5V	≈ 4.7V	3.25V (2 Diodes)
39k	≈ 7.6μs	≈ 7.3V	≈ 5.6V	4.15V (2 Diodes)
47k	≈ 9μs	≈ 8.4V	≈ 6.8V	5.35V (2 Diodes)

Table 1 Reference resistor, reaction time and turn-off threshold

Notes on Table 1

The values for "Vth1" and "Vth2" are listed in **Table 1** as a function of the reference resistance Rth.

The value in the "Vth1" column corresponds to the voltage threshold after the response time has elapsed.

The value in the "Vth2" column corresponds to the voltage which is set up statically across the resistor Rth. This static value is typically reached after between 10 and 15μs.

2SD106AI-17 UL Data Sheet

The value in the “ $V_{CE(off)}$ ” column corresponds to the collector-emitter voltage value at which the protection function is activated when the external circuit is used as shown in Fig. 4 with one or two Dm diodes of type 1N4007 connected in series.

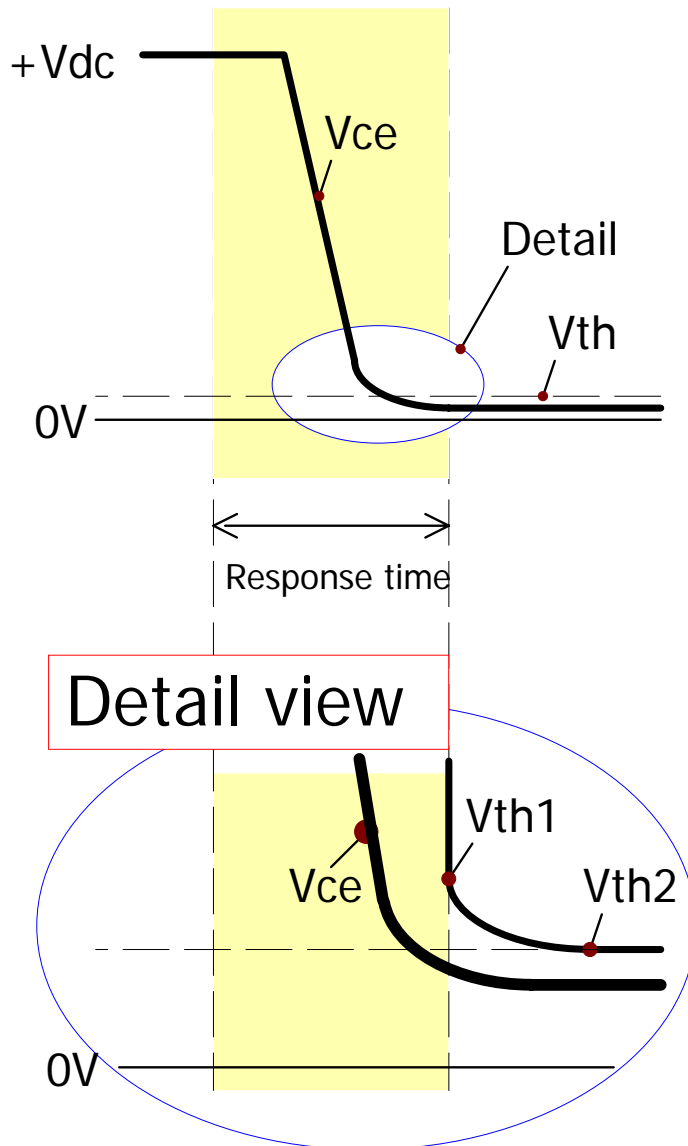

Fig. 5 Collector-sense voltage curve

If you need any help, simply call our technical support

CONCEPT provides expert help with your questions and problems:

www.IGBT-Driver.com/go/support

Quite special: customized SCALE drivers

If you need a power MOSFET or IGBT driver that is not included in the delivery range, don't hesitate to contact CONCEPT or your CONCEPT sales partner.

CONCEPT engineers have more than 20 years experience in the development and manufacture of intelligent drivers for power MOSFETs and IGBTs and have already implemented a large number of customized solutions.

Important Notice

The data contained in this product data sheet is intended exclusively for technically trained staff. Handling all high-voltage equipment involves risk to life. Strict compliance with the respective safety regulations is mandatory!

Any handling of electronic devices is subject to the general specifications for protecting electrostatic-sensitive devices according to international standard IEC 747-1, Chapter IX or European standard EN 100015 (i.e. the workplace, tools, etc. must comply with these standards). Otherwise, this product may be damaged.

Legal Disclaimer

This data sheet specifies devices but cannot promise to deliver any specific characteristics. No warranty or guarantee is given – either expressly or implicitly – regarding delivery, performance or suitability.

CT-Concept Technologie AG reserves the right to make modifications to its technical data and product specifications at any time without prior notice. The general terms and conditions of delivery of CT-Concept Technologie AG apply.

2SD106AI-17 UL Data Sheet

Ordering Information

UL Compliant Dual SCALE driver with $\pm 6A$ gate current / $\pm 15V$ gate voltage

2SD106AI-17 UL

Information about Other Products

For other drivers, product documentation, and application support

Direct link: Please click: www.IGBT-Driver.com

Manufacturer

CT-Concept Technologie AG
Intelligent Power Electronics
Renferstrasse 15
CH-2504 Biel-Bienne
Switzerland

Tel. +41 - 32 - 344 47 47

Fax +41 - 32 - 344 47 40

E-mail Info@IGBT-Driver.com

Internet www.IGBT-Driver.com

© Copyright 1998...2009 by CT-Concept Technologie AG - Switzerland.

All rights reserved.

We reserve the right to make any technical modifications without prior notice. Version from 2009-09-15

X-ON Electronics

Largest Supplier of Electrical and Electronic Components

Click to view similar products for [Gate Drivers](#) category:

Click to view products by [Power Integrations](#) manufacturer:

Other Similar products are found below :

[00053P0231](#) [56956](#) [57.404.7355.5](#) [LT4936](#) [57.904.0755.0](#) [5882900001](#) [00600P0005](#) [00-9050-LRPP](#) [00-9090-RDPP](#) [5951900000](#) [01-1003W-10/32-15](#) [0131700000](#) [00-2240](#) [LTP70N06](#) [LVP640](#) [5J0-1000LG-SIL](#) [LY1D-2-5S-AC120](#) [LY2-US-AC240](#) [LY3-UA-DC24](#) [00576P0020](#) [00600P0010](#) [LZN4-UA-DC12](#) [LZNQ2M-US-DC5](#) [LZNQ2-US-DC12](#) [LZP40N10](#) [00-8196-RDPP](#) [00-8274-RDPP](#) [00-8275-RDNP](#) [00-8722-RDPP](#) [00-8728-WHPP](#) [00-8869-RDPP](#) [00-9051-RDPP](#) [00-9091-LRPP](#) [00-9291-RDPP](#) [0207100000](#) [0207400000](#) [01312](#) [0134220000](#) [60713816](#) [M15730061](#) [61161-90](#) [61278-0020](#) [6131-204-23149P](#) [6131-205-17149P](#) [6131-209-15149P](#) [6131-218-17149P](#) [6131-220-21149P](#) [6131-260-2358P](#) [6131-265-11149P](#) [CS1HCPU63](#)