

CAP300DG CAPZero™-3

Zero¹ Loss Automatic X Capacitor Rapid Discharge IC

Product Highlights

- Meets IEC 60335 X capacitor discharge of <34 V in <1 sec
- One part to cover X capacitor values up to 6 μF
- Blocks current through X capacitor discharge resistors when AC voltage is connected
- Automatically discharges X capacitors through discharge resistors when AC is disconnected
- Simplifies EMI filter design – larger X capacitor allows smaller inductive components with no change in consumption
- Only two terminals – meets safety standards for use before or after system input fuse
- >4 mm creepage on package and PCB
- Self supplied – no external bias required
- High common mode surge immunity – no external ground connection
- High differential surge withstand – 1000 V internal MOSFETs
- NEMKO and CB certification

EcoSmart™ – Energy Efficient

- <5 mW consumption at 230 VAC for all X capacitor values

Applications

- All AC-DC converters with X capacitors of 100 nF up to 6 μF
- Appliances requiring ErP Lot 6 compliance
- Adapters requiring ultra low no-load consumption
- All converters requiring very low standby power
- Lossless generation of zero crossing signal

Description

When AC voltage is applied, CAP300DG blocks current flow in the X capacitor safety discharge resistors, reducing the power loss to less than 5 mW, or essentially zero¹ at 230 VAC. When AC voltage is disconnected, CAP300DG automatically discharges the X capacitor by connecting the series discharge resistors. This operation allows total flexibility in the choice of the X capacitor to optimize differential mode EMI filtering and reduce inductor costs, with no change in power consumption.

Designing with CAP300DG is simply a matter of selecting the appropriate external resistor values for the X capacitor value being used to achieve the necessary time constant. The simplicity and ruggedness of the two terminal CAP300DG IC makes it an ideal choice in systems designed to meet ErP Lot 6 requirements.

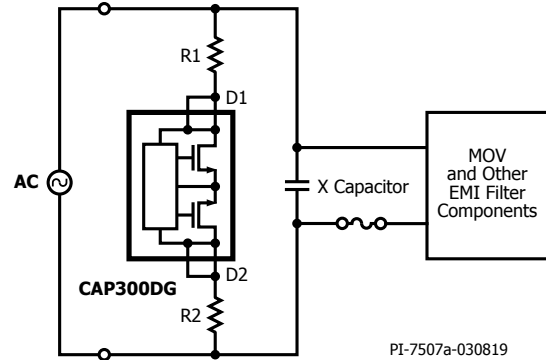

Figure 1. Typical Application – Not a Simplified Circuit.

Component Table

Product ³	BV _{DSS}	Total X Capacitance	Total Series Resistance ² (R1 + R2)
CAP300DG	1000 V	200 nF to 6 μF	54 k Ω Minimum

Table 1. Component Table.

Notes:

1. IEC 62301 clause 4.5 rounds standby power use below 5 mW to zero.
2. Values are nominal. RC time constant is <1 second.
3. Packages: D: SO-8.

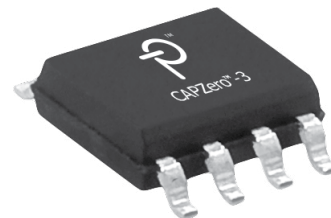

Figure 2. SO-8 D Package.

Pin Functional Description

The pin configuration of Figure 3 ensures that the width of the SO-8 package is used to provide creepage and clearance distance of over 4 mm.

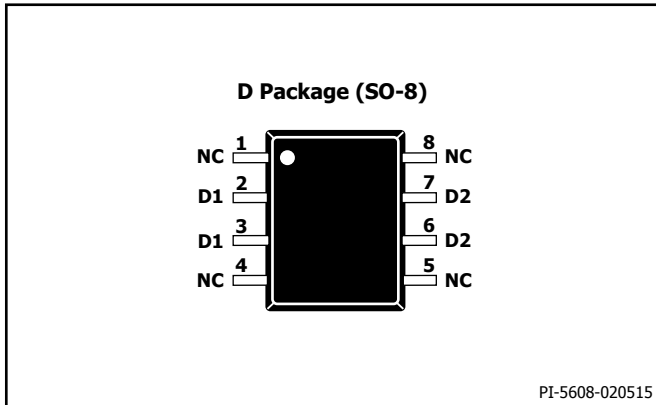

Figure 3. Pin Configuration.

Although electrical connections are only made to pins 2, 3, 6 and 7, it is recommended that pins 1-4 and pins 5-8 are coupled together on the PCB – see Applications Section.

Key Application Considerations

Breakdown Voltage Selection

The system configuration variables include the placement of the system MOV and X capacitor(s) as well as the differential surge voltage specifications of the application.

As shown in Table 1, the CAP300DG has a breakdown voltage of 1000 V. For applications where the system MOV is placed in position 1 (MOV_{POS1} in Figure 4), the CAP300DG will provide adequate voltage withstand for surge requirements of 3 kV or higher.

For MOV placement that is not directly across the X Capacitor1 (for example MOV_{POS2} in Figure 4) the CAP300DG devices can be used up to a surge specification of 1.5 kV. For differential surge voltage specifications of >1.5 kV it is recommended that the MOV is always placed in the location shown in Figure 4 as MOV_{POS1}.

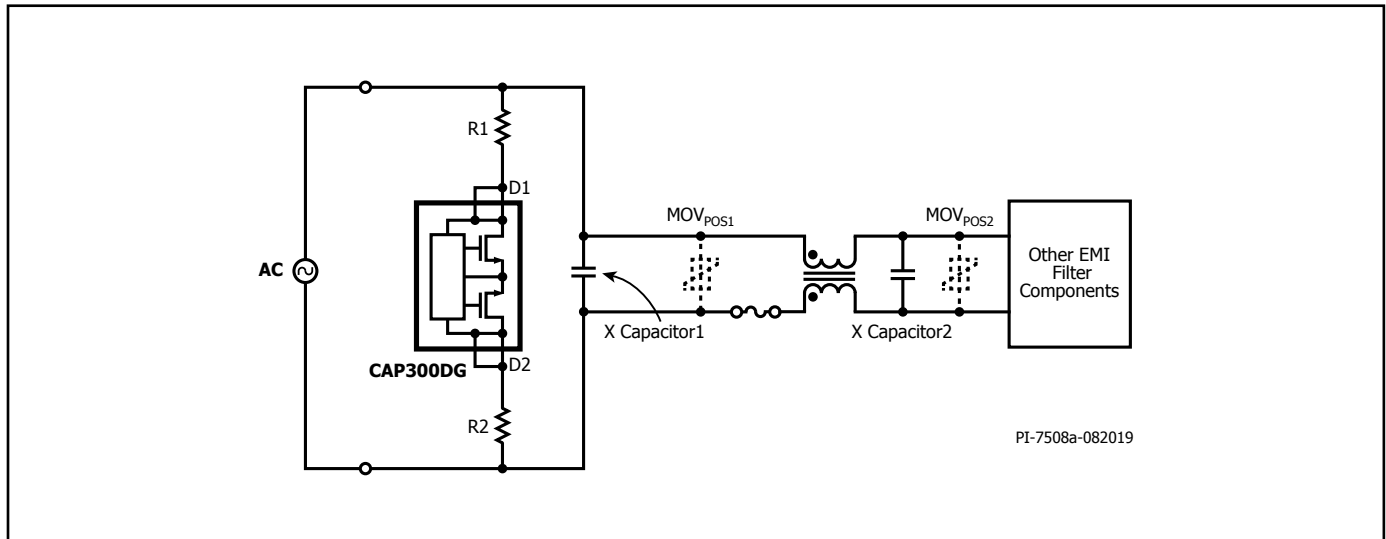

Figure 4. Placement Options of MOV.

PCB Layout and External Resistor Selection

Figure 5 shows a typical PCB layout configuration for CAP300DG. The external resistors in this case are divided into two separate surface mount resistors to distribute loss under fault conditions – for example where a short-circuit exists between CAP300DG terminals D1 and D2.

Resistors R1 and R2 should also be rated for 50% of the system input voltage again to allow for the short-circuiting of CAP300DG D1 to D2 pins during single point fault testing.

If lower dissipation or lower voltage across each resistor is required during fault tests, the total external resistance can be divided into more discrete resistors, however the total resistance must be equal to or greater than 54 k Ω .

Safety

CAP300DG meets safety requirements even if placed before the system input fuse. If a short-circuit is placed between D1 and D2 terminals of CAP300DG, the system is identical to existing systems where CAP300DG is not used.

With regard to open circuit tests, it is not possible to create a fault condition through a single pin fault (for example lifted pin test) since there are two pins connected to each of D1 and D2. If several pins are lifted to create an open circuit, the condition is identical to an open circuit X capacitor discharge resistor in existing systems where CAP300DG is not used. If redundancy against open circuit faults is required, two CAP300DG and R1 / R2 configurations can be placed in parallel.

Discharge Operation

To meet the safety regulations of appliances, when the AC supply is disconnected, CAP300DG will discharge the X capacitor to <34 V levels according to the above functional description.

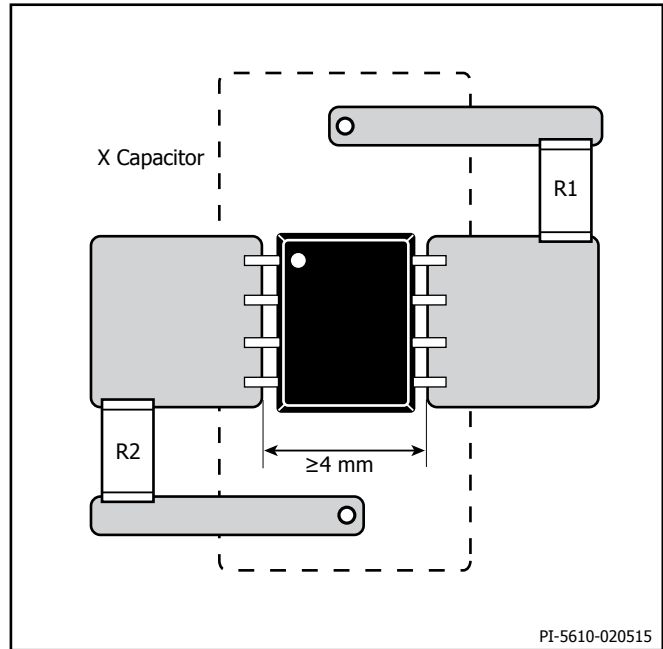

Figure 5. Typical PCB Layout.

Absolute Maximum Ratings⁽⁴⁾

DRAIN Pin Voltage ⁽¹⁾	1000 V	Notes:
DRAIN Peak Current ⁽²⁾	10.9 mA	1. Voltage of D1 pin relative to D2 pin in either polarity.
Storage Temperature	-65 °C to 150 °C	2. The peak DRAIN current is allowed while the DRAIN voltage is simultaneously less than 400 V.
Lead Temperature ⁽³⁾	260 °C	3. 1/16 in. from case for 5 seconds.
Operating Ambient Temperature.....	-10 °C to 105 °C	4. The Absolute Maximum Ratings specified may be applied one at a time without causing permanent damage to the product.
Maximum Junction Temperature.....	-10 °C to 110 °C	Exposure to Absolute Maximum Rating conditions for extended periods of time may affect product reliability.

Thermal Resistance

Thermal Resistance: D Package ⁽¹⁾ :	Notes:
(θ_{JA}).....160 °C/W (Single layer JEDEC PCB)	1. Reference thermal resistance test conditions: JEDEC JESD51-3, SEMI Test Method #G43-87, and MIL-STD-883 Method 10121.1.
(θ_{JC}).....40 °C/W (Bottom)	
(θ_{JC}).....75 °C/W (Top)	

Parameter	Symbol	Conditions	Min	Typ	Max	Units
		$T_A = -10$ to 105 °C (Unless Otherwise Specified)				
Control Functions						
AC Removal Detection Time	t_{DETECT}	Line Cycle Frequency 47-63 Hz		22	31.4	ms
Drain Saturation Current^{A,B}	I_{DSAT}	CAP300DG	6.3			mA
Supply Current	I_{SUPPLY}	$T_A = 25$ °C			21.7	μA

NOTES:

- A. Saturation current specifications ensure a natural RC discharge characteristic at all voltages up to 265 VAC peak with the external resistor values specified in Table 1.
- B. Specifications are guaranteed by characterization and design.

Typical Performance Characteristics

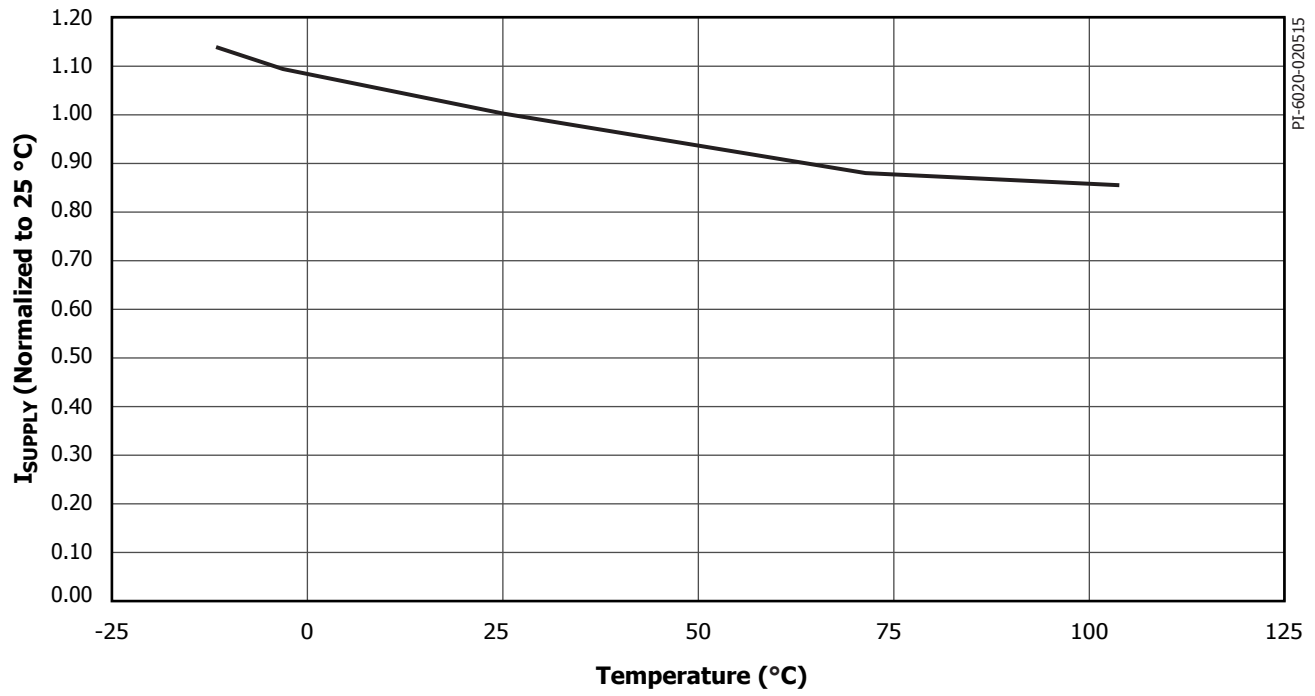
Figure 6. I_{SUPPLY} vs. Temperature.

SO-8 (D Package)

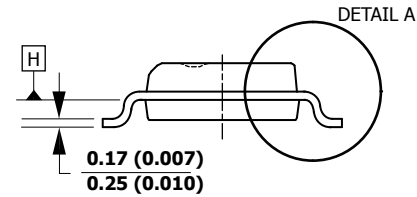
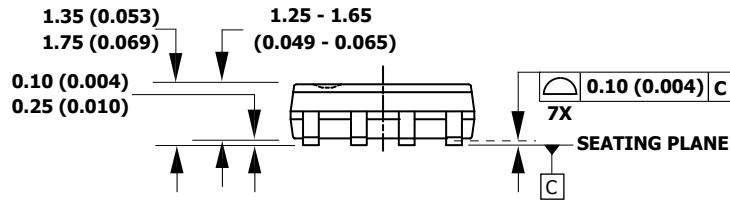
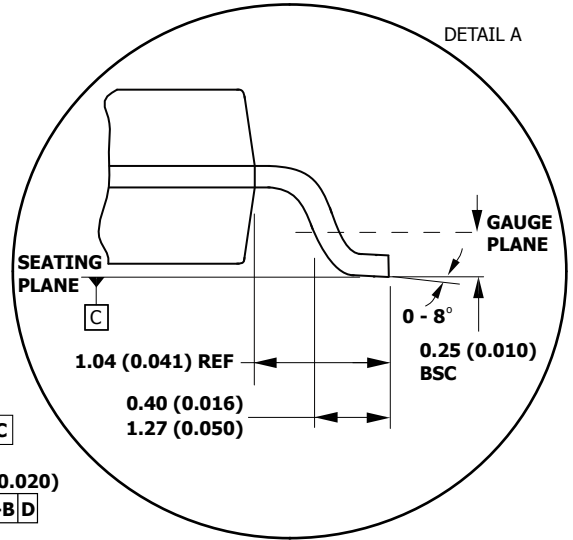
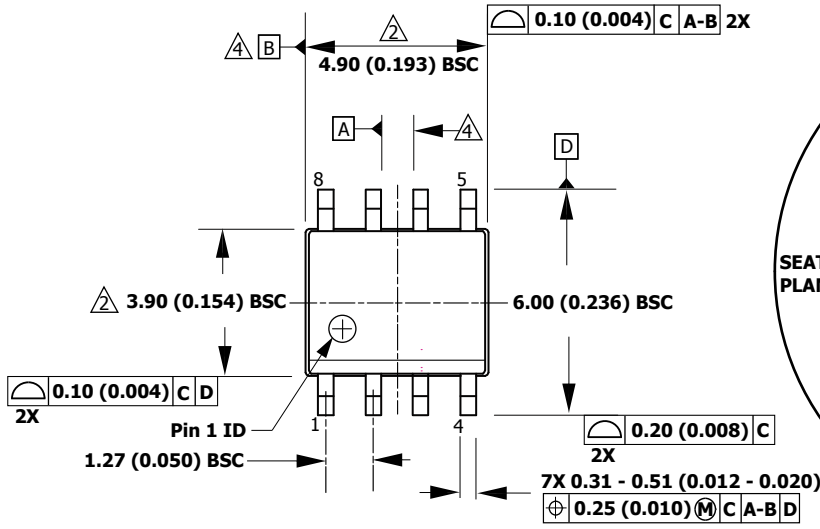

Reference Solder Pad Dimensions

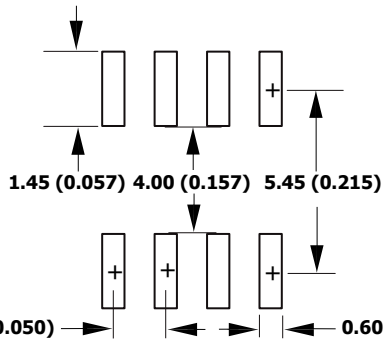

Notes:

1. JEDEC reference: MS-012.
2. Package outline exclusive of mold flash and metal burr.
3. Package outline inclusive of plating thickness.
4. Datums A and B to be determined at datum plane H.
5. Controlling dimensions are in millimeters. Inch dimensions are shown in parenthesis. Angles in degrees.

D08A

PI-5615-020515

Part Ordering Information

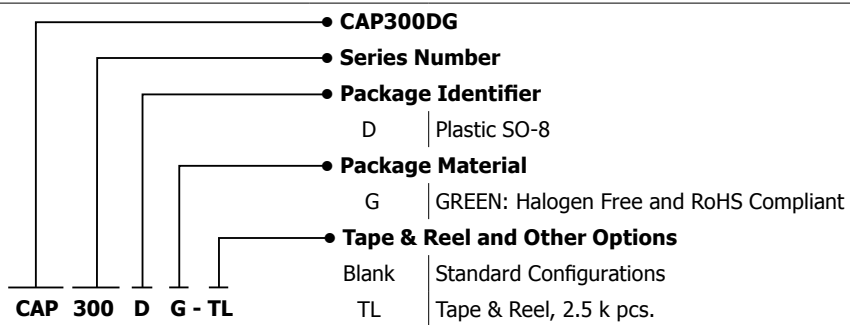

Revision	Notes	Date
B	Code A release.	08/19
C	Updated per Nemko and CB certification.	02/20

For the latest updates, visit our website: www.power.com

Power Integrations reserves the right to make changes to its products at any time to improve reliability or manufacturability. Power Integrations does not assume any liability arising from the use of any device or circuit described herein. POWER INTEGRATIONS MAKES NO WARRANTY HEREIN AND SPECIFICALLY DISCLAIMS ALL WARRANTIES INCLUDING, WITHOUT LIMITATION, THE IMPLIED WARRANTIES OF MERCHANTABILITY, FITNESS FOR A PARTICULAR PURPOSE, AND NON-INFRINGEMENT OF THIRD PARTY RIGHTS.

Patent Information

The products and applications illustrated herein (including transformer construction and circuits external to the products) may be covered by one or more U.S. and foreign patents, or potentially by pending U.S. and foreign patent applications assigned to Power Integrations. A complete list of Power Integrations patents may be found at www.power.com. Power Integrations grants its customers a license under certain patent rights as set forth at www.power.com/ip.htm.

Life Support Policy

POWER INTEGRATIONS PRODUCTS ARE NOT AUTHORIZED FOR USE AS CRITICAL COMPONENTS IN LIFE SUPPORT DEVICES OR SYSTEMS WITHOUT THE EXPRESS WRITTEN APPROVAL OF THE PRESIDENT OF POWER INTEGRATIONS. As used herein:

1. A Life support device or system is one which, (i) is intended for surgical implant into the body, or (ii) supports or sustains life, and (iii) whose failure to perform, when properly used in accordance with instructions for use, can be reasonably expected to result in significant injury or death to the user.
2. A critical component is any component of a life support device or system whose failure to perform can be reasonably expected to cause the failure of the life support device or system, or to affect its safety or effectiveness.

Power Integrations, the Power Integrations logo, CAPZero, ChiPhy, CHY, DPA-Switch, EcoSmart, E-Shield, eSIP, eSOP, HiperPLC, HiperPFS, HiperTFS, InnoSwitch, Innovation in Power Conversion, InSOP, LinkSwitch, LinkZero, LYTSwitch, SENZero, TinySwitch, TOPSwitch, PI, PI Expert, PowiGaN, SCALE, SCALE-1, SCALE-2, SCALE-3 and SCALE-iDriver, are trademarks of Power Integrations, Inc. Other trademarks are property of their respective companies. ©2020, Power Integrations, Inc.

Power Integrations Worldwide Sales Support Locations

World Headquarters

5245 Hellyer Avenue
San Jose, CA 95138, USA
Main: +1-408-414-9200
Customer Service:
Worldwide: +1-65-635-64480
Americas: +1-408-414-9621
e-mail: usasales@power.com

China (Shanghai)

Rm 2410, Charity Plaza, No. 88
North Caoxi Road
Shanghai, PRC 200030
Phone: +86-21-6354-6323
e-mail: chinasales@power.com

China (Shenzhen)

17/F, Hivac Building, No. 2, Keji Nan
8th Road, Nanshan District,
Shenzhen, China, 518057
Phone: +86-755-8672-8689
e-mail: chinasales@power.com

Germany (AC-DC/LED Sales)

Einsteinring 24
85609 Dornach/Aschheim
Germany
Tel: +49-89-5527-39100
e-mail: eurosales@power.com

Germany (Gate Driver Sales)

HellwegForum 1
59469 Ense
Germany
Tel: +49-2938-64-39990
e-mail: igbt-driver.sales@power.com

India

#1, 14th Main Road
Vasanthanagar
Bangalore-560052 India
Phone: +91-80-4113-8020
e-mail: indiasales@power.com

Italy

Via Milanese 20, 3rd. Fl.
20099 Sesto San Giovanni (MI) Italy
Phone: +39-024-550-8701
e-mail: eurosales@power.com

Japan

Yusen Shin-Yokohama 1-chome Bldg.
1-7-9, Shin-Yokohama, Kohoku-ku
Yokohama-shi,
Kanagawa 222-0033 Japan
Phone: +81-45-471-1021
e-mail: japansales@power.com

Korea

RM 602, 6FL
Korea City Air Terminal B/D, 159-6
Samsung-Dong, Kangnam-Gu,
Seoul, 135-728, Korea
Phone: +82-2-2016-6610
e-mail: koreasales@power.com

Singapore

51 Newton Road
#19-01/05 Goldhill Plaza
Singapore, 308900
Phone: +65-6358-2160
e-mail: singaporesales@power.com

Taiwan

5F, No. 318, Nei Hu Rd., Sec. 1
Nei Hu Dist.
Taipei 11493, Taiwan R.O.C.
Phone: +886-2-2659-4570
e-mail: taiwansales@power.com

UK

Building 5, Suite 21
The Westbrook Centre
Milton Road
Cambridge
CB4 1YG
Phone: +44 (0) 7823-557484
e-mail: eurosales@power.com

X-ON Electronics

Largest Supplier of Electrical and Electronic Components

Click to view similar products for [Power Management Specialised - PMIC category](#):

Click to view products by [Power Integrations manufacturer](#):

Other Similar products are found below :

[LV5686PVC-XH](#) [FAN7710VN](#) [NCP391FCALT2G](#) [SLG7NT4081VTR](#) [SLG7NT4192VTR](#) [AP4313UKTR-G1](#) [AS3729B-BWLM](#)
[MB39C831QN-G-EFE2](#) [MAX4940MB](#) [LV56841PVD-XH](#) [MAX77686EWE+T](#) [AP4306BUKTR-G1](#) [MIC5164YMM](#) [PT8A3252WE](#)
[NCP392CSFCCT1G](#) [TEA1998TS/1H](#) [PT8A3284WE](#) [PI3VST01ZEEX](#) [PI5USB1458AZAEX](#) [PI5USB1468AZAEX](#) [MCP16502TAC-E/S8B](#)
[MCP16502TAE-E/S8B](#) [MCP16502TAA-E/S8B](#) [MCP16502TAB-E/S8B](#) [ISL91211AIKZT7AR5874](#) [ISL91211BIKZT7AR5878](#)
[MAX17506EVKITBE#](#) [MCP16501TC-E/RMB](#) [ISL91212AIIZ-TR5770](#) [ISL91212BIIZ-TR5775](#) [CPX200D](#) [TP-1303](#) [TP-1305](#) [TP-1603](#) [TP-](#)
[2305](#) [TP-30102](#) [TP-4503N](#) [MIC5167YML-TR](#) [LPTM21-1AFTG237C](#) [MPS-3003L-3](#) [MPS-3005D](#) [SPD-3606](#) [MMPF0200F6AEP](#)
[STLUX383A](#) [TP-60052](#) [ADN8834ACBZ-R7](#) [LM26480SQ-AA/NOPB](#) [LM81BIMTX-3/NOPB](#) [LM81CIMT-3/NOPB](#) [MIC5166YML-TR](#)