

Innovation in power conversion

PoE Interface

L1  
10  $\mu$ H  
1 A

C4  
1000 pF  
1500 V  
R7  
10 k $\Omega$   
1 9,10

# Product Selector Guide DC-DC Products

September 2008



## Features & Benefits

**The DPA-Switch Family** combines a 220 V power MOSFET with a controller that provides current monitoring, undervoltage and over temperature protection, soft start and other control functions in a single device, saving up to 30 external components in the power supply design. Combining the key switching elements into a single package reduces design complexity and ensures rapid, low-risk development of highly cost-effective power supplies.

**Superior Performance and Flexibility.** The DPA-Switch family supports a range of power requirements in either forward or flyback topologies and offers a variety of package options to maximize design flexibility. A DIP-8 package is available for low-cost designs, and a thermally efficient TO-263-7C R package (2 °C/Watt) is available for higher power applications.

### Product Highlights

- Supports flyback and forward topology
- Programmable internal current sense eliminates external sense components
- Built-in auto-restart for output overload/open loop protection
- Line undervoltage (UV) detection: meets ETSI standards
- Line overvoltage (OV) shutdown protection
- Fully integrated soft-start for minimum stress/overshoot
- Hysteretic thermal shutdown for over temperature protection and automatic recovery
- Source connected tab for low EMI

### EcoSmart® Energy Efficiency

- Extremely low consumption at no-load (10 mA typ.) and in remote off (2 mA max.)
- Cycle skipping at light load for high standby efficiency



### Package Information

- P and G packages have Pb-free finish (100% matte tin), are RoHS compliant and meet requirements of JEDEC standard J-STD-020C table 4.2. The R package is not available in Pb-free finish.

**G-Package**

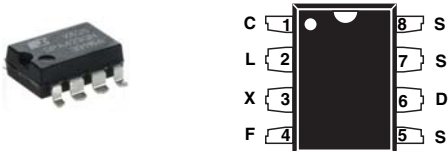

**P-Package**

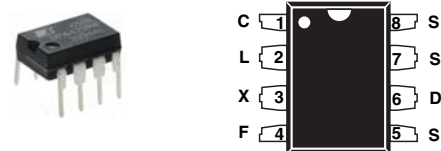

**R-Package**

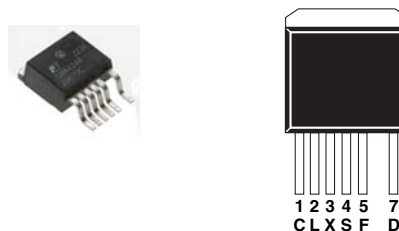

### Typical Applications

- PoE applications: VoIP phones, WLAN, security cameras
- Telco central office equipment: xDSL, ISDN, PABX
- Distributed power architectures (24 V/48 V bus)
- Industrial controls
- LED lighting

## Product Selector Guide

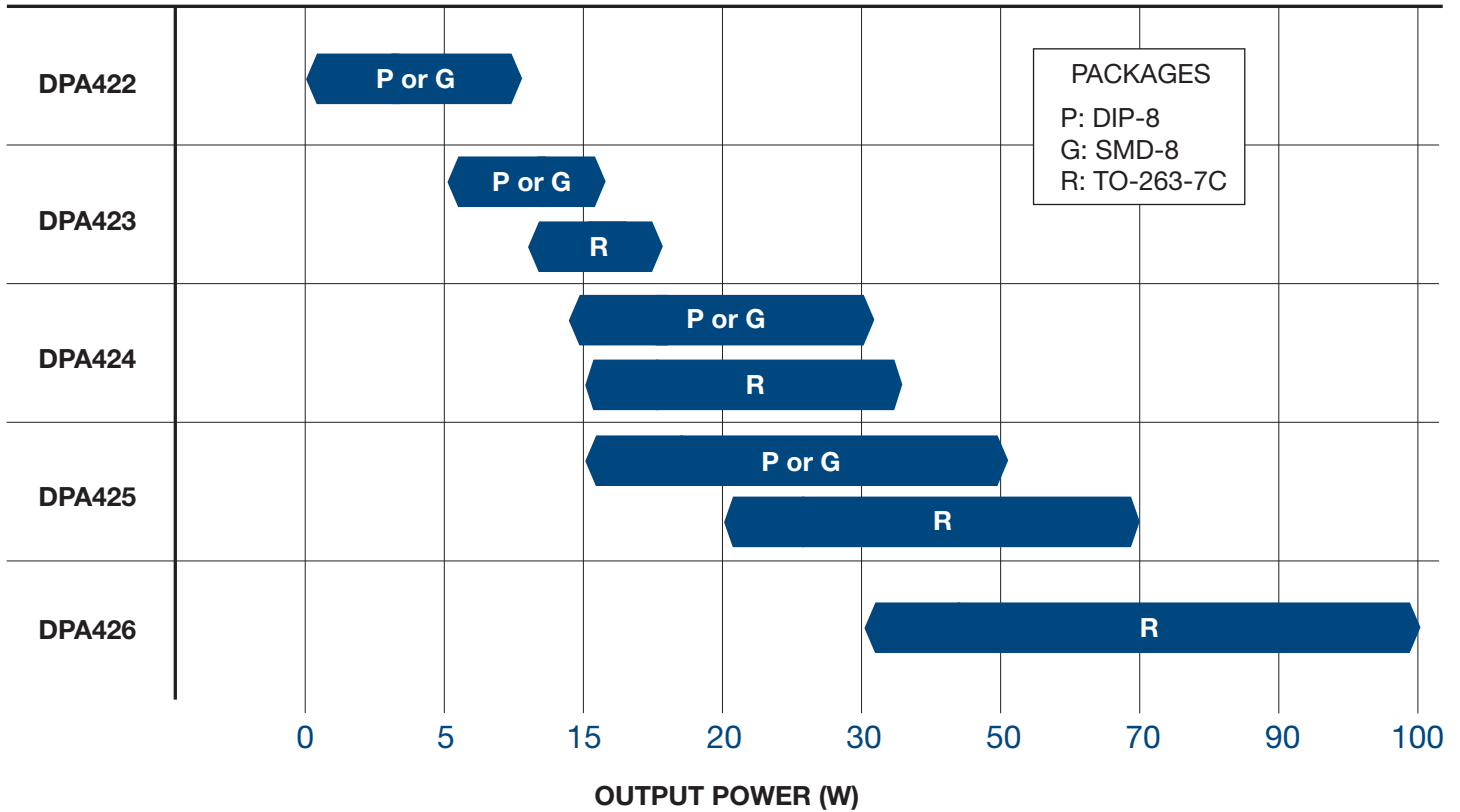

## 24 V / 48 V DC-DC Power Conversion (Up to 100 W)

### Output Power Table

Total Device Dissipation <sup>3</sup> PRODUCT <sup>4</sup>	36-75 VDC Input Range (Forward) <sup>2</sup>					
	0.5 W	1 W	2.5 W	4 W	6 W	Max Power Output <sup>1</sup>
DPA422 <sup>7</sup>	7.5 W	10 W	-	-	-	10 W
DPA423	12 W	16 W	-	-	-	18 W
DPA424	16 W	23 W	35 W	-	-	35 W
DPA425	23 W	32 W	50 W	62 W	-	70 W
DPA426 <sup>5</sup>	25 W	35 W	55 W	70 W	83 W	100 W

Total Device Dissipation <sup>3</sup> PRODUCT <sup>4</sup>	36-75 VDC Input Range (Flyback) <sup>2</sup>				
	0.5 W	0.75 W	1 W	1.5 W	Max Power Output <sup>1</sup>
DPA422 <sup>7</sup>	6.5 W	9 W	-	-	9 W
DPA423	9 W	13 W	-	-	13 W
DPA424	10 W	14.5 W	18 W	24 W	26 W
DPA425	- <sup>6</sup>	- <sup>6</sup>	- <sup>6</sup>	25.5 W	52 W

Notes:  
1. Maximum output power is limited by device internal current limit. 2. See Applications Considerations section of the DPA-Switch data sheet for complete description of assumptions and for output powers with other input voltage ranges. 3. For device dissipation of 1.5 W or below, use P or G packages. Device dissipation above 1.5 W is possible with R packages. 4. Packages: P: DIP-8, G: SMD-8, R: TO-263-7C. For lead-free package options, see Part Ordering section of the DPA-Switch data sheet. 5. Available in R package only. 6. Due to higher switching losses, the DPA425 may not deliver additional power compared to a smaller device. 7. Available in P and G package only.

### Integrated Features

HV-FET Rating	220 V	Soft Start	✓	Hysteretic Thermal Shutdown	✓	Remote ON/OFF	✓
Switching Frequency (kHz)	400/ 300	Fully Integrated Current Sensing	✓	Power Limiting	✓	EcoSmart® Low Standby/ No-load Power Consumption	✓
Max. Duty Cycle (DC <sub>MAX</sub> )	75%	Adjustable Current Limit	✓	Line UV Detection	✓	Synchronizable to Lower External Clock Frequency	✓
Control Method	PWM	Auto Restart	✓	Line OV Detection	✓	Remote ON/OFF	✓

## DPA-Switch in PoE Applications

**Power over Ethernet (PoE)** is a method whereby power is transmitted to Ethernet-connected equipment (VoIP telephones, WLAN transmitters, security cameras) from the central switch. Power Integrations has developed circuits for highly cost-effective IEEE802.3af compliant power supplies. Tested by the University of New Hampshire's Interoperability Consortium (UNH-IOC), PI solutions have been shown to work with all available Power Sourcing Equipment (PSE). The results of the UNH-IOC testing are shown on the PI website.

**Operation:** PoE Powered Device (PD) fulfills three functions to work in conjunction with the sending end PSE: detection, classification and undervoltage lockout.

**Detection Phase:** The PSE checks the PD to determine if it is PoE-enabled. During the detection phase, the PSE applies a voltage ramp to the PD and looks for a characteristic impedance from the load (25 kΩ). If the signature impedance is detected, the PSE moves on to the classification phase. The signature identification voltage is a ramp voltage between 2.5 V and 10 V. A 24.9 kΩ resistor provides the correct signature impedance for detection.

**Classification Phase:** The PSE continues to ramp the voltage to the PD. Between 14.5 V and 20.5 V, the PD must draw a specified current to identify the device class. The classification current describes the amount of power the PD will require during normal operation. A table of classification current and operating PD power requirements is shown below.

**Classification Power Levels**

Class	Power (Min)	Power (Max)	Class (Min)	I <sub>CLASS</sub> (Max)
0	0.44 W	12.95 W	0 mA	4 mA
1	0.44 W	3.84 W	9 mA	12 mA
2	3.84 W	6.49 W	17 mA	20 mA
3	6.49 W	12.95 W	26 mA	30 mA
4	Reserved	Reserved	36 mA	44 mA

Table 1. Classification Power Levels.

**PoE Class 0 Interface with MOSFET Pass-Switch**

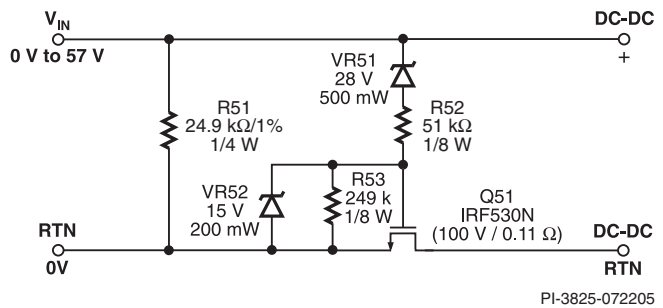
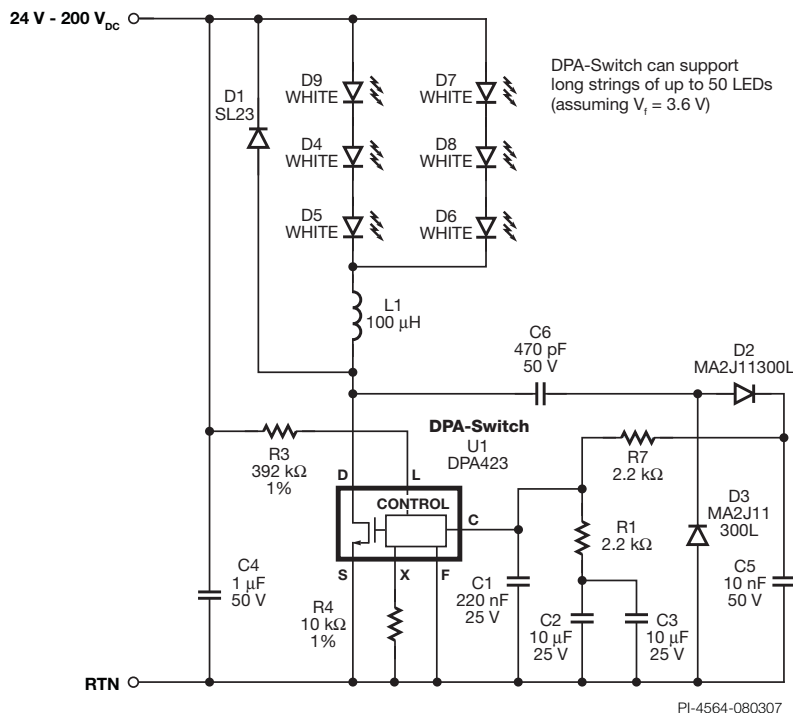

Figure 1. PoE Class 0 Interface Circuit Using a MOSFET Pass-Switch.

**Turn-on Phase:** The PSE continues to ramp the input voltage up to 30 V. When the undervoltage lockout (UVLO) circuit is released the PD is allowed to power up. A typical undervoltage lockout circuit is shown in the Figure above.

For additional information see Design Ideas DI-70 ([www.powerint.com/PDFFiles/di70.pdf](http://www.powerint.com/PDFFiles/di70.pdf)) & DI-88 ([www.powerint.com/PDFFiles/di88.pdf](http://www.powerint.com/PDFFiles/di88.pdf)), also Reference Design Kits DAK-68A and DAK-86.

## DPA-Switch – Constant Current LED Driver (10 W, 500 mA)



# DPA-Switch vs. Discrete Design

33-57 VDC Input, 12.95 W Class Programmable Power over Ethernet DC-DC Converter (see DAK-86)

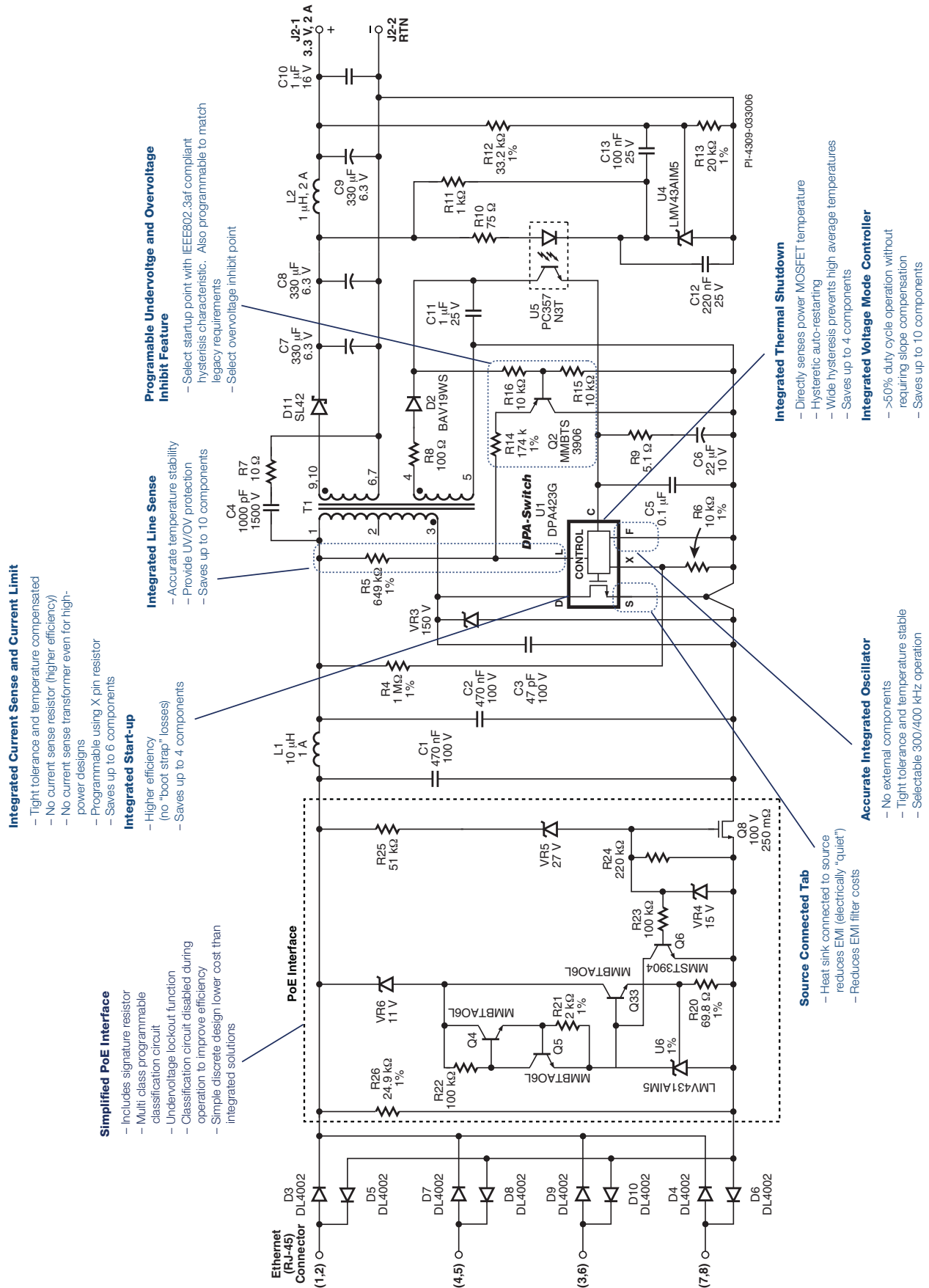

# Design Examples

## Cost-Effective 6.6 W, 3.3 V Flyback DC-DC Converter (EP-86)

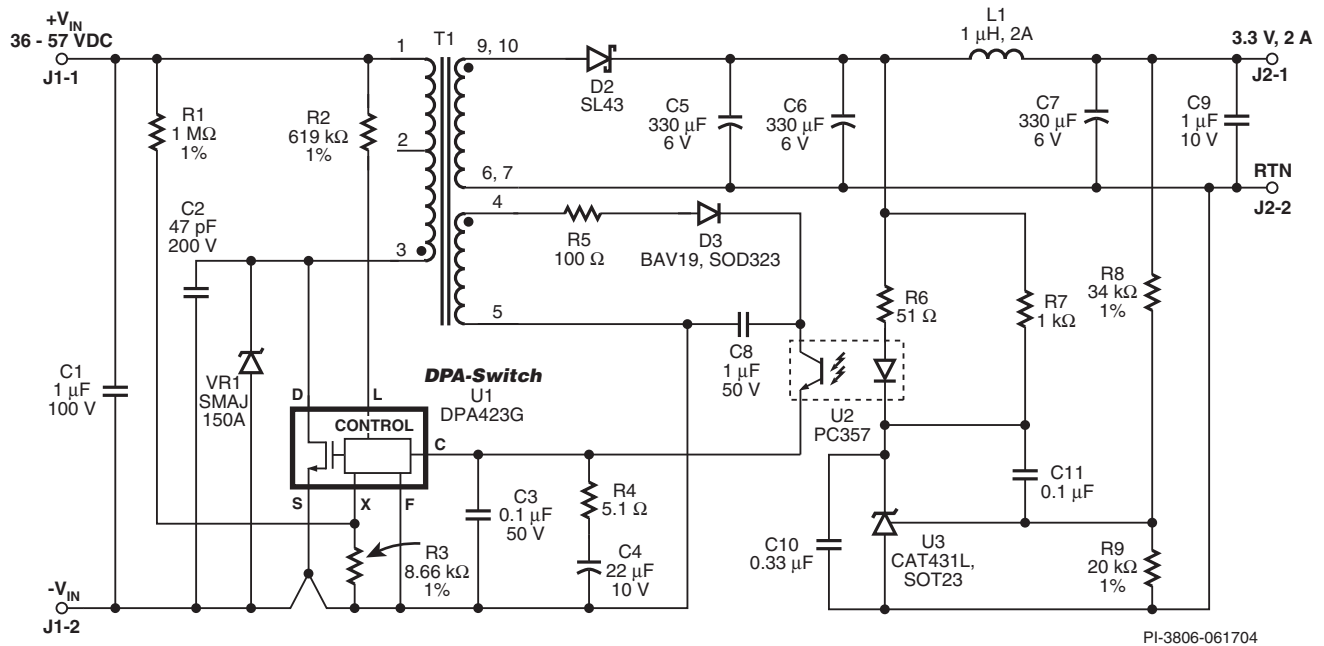

## 15 W Multi-Output DC-DC Converter (DI-69)

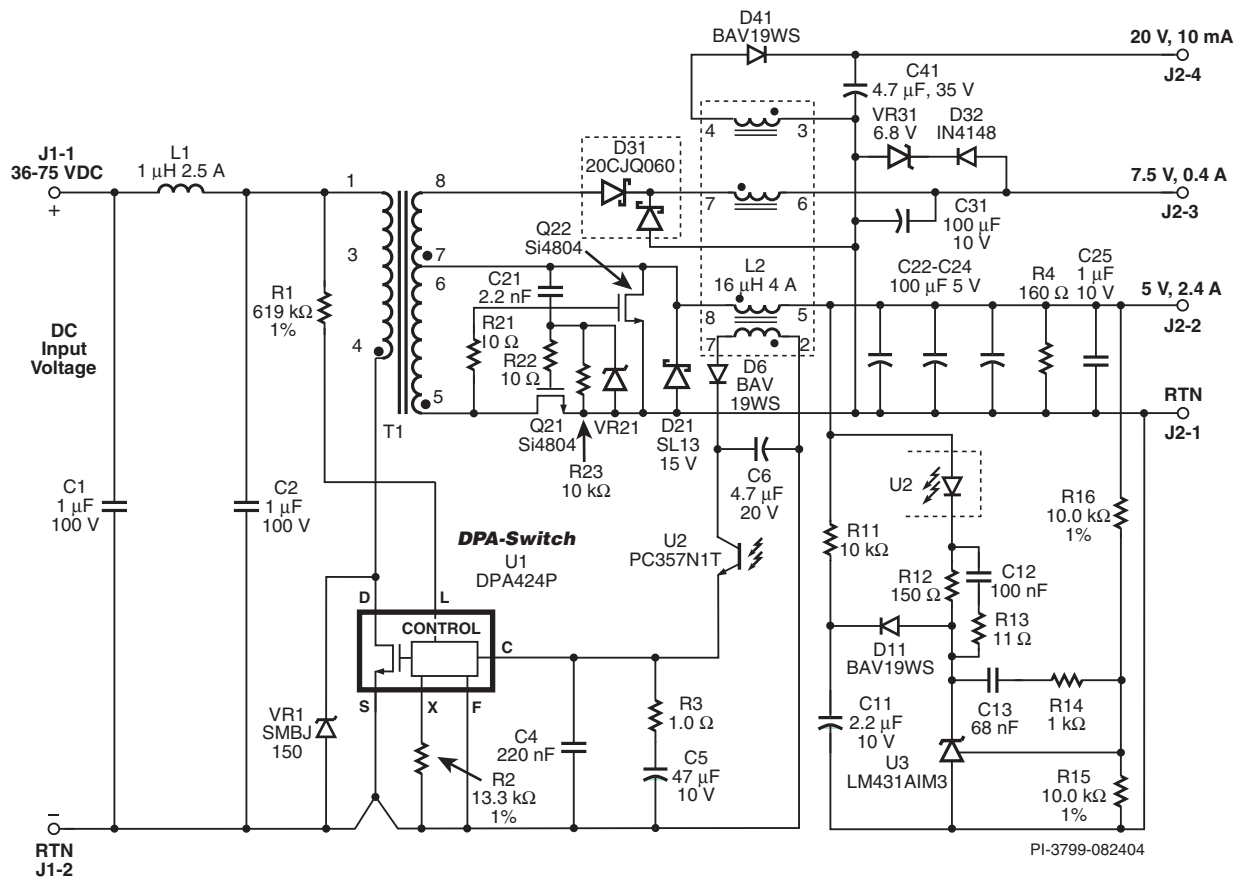

Visit [www.powerint.com/appcircuits.htm](http://www.powerint.com/appcircuits.htm) for additional design examples.

## Design Tools

### Reference Design Kits (RDks)

RDks include a working prototype power supply, sample devices, unpopulated pcb, data sheet, comprehensive engineering report and other related documentation.

<b>DAK-21A</b>	30 W, DC-DC Forward Converter
<b>DAK-68A</b>	6.6 W, Class 0 PoE Converter
<b>DAK-71A</b>	6 W, DC-DC Converter
<b>DAK-86</b>	6.6 W, Multi-Class Programmable PoE Powered Device



### Power Supply Design Software\*

With **PI Expert™** Suite, you're only "mouse clicks" away from determining the key components in your next switching power supply design, including the best Power Integrations power IC and detailed instructions for building the transformer! It's fast & easy... and best of all, **FREE!**

### DPA-Switch Product and Design Collateral\*

<b>Data Sheet</b>	<b>DPA422-426</b>	DPA-Switch Family Data Sheet
<b>Application Note</b>	<b>AN-31</b>	DPA-Switch DC-DC Forward Converter Design Guide
<b>Design Ideas (2-page technical Circuit Document)</b>	<b>DI-24</b>	Application: Telecom (36-75 VDC Input): 30 W, 5 V Forward Converter
	<b>DI-25</b>	Application: Telecom (36-75 VDC Input): 30 W, 5 V Forward Converter (Sync. Rectification)
	<b>DI-29</b>	Application: Telecom (36-75 VDC Input): 25 W, 7 V Flyback Converter
	<b>DI-31</b>	Application: Telecom (36-75 VDC Input): 70 W, 5 V Forward Converter
	<b>DI-37</b>	Application: Telecom (36-75 VDC Input): 16.5 W, 3.3 V Forward Converter (Sync. Rectification)
	<b>DI-40</b>	Application: Telecom (36-75 VDC Input): 20 W, 2.5 V Forward Converter (Sync. Rectification)
	<b>DI-51</b>	Application: Telecom (36-75 VDC Input): 5 W, 5 V Flyback Converter
	<b>DI-52</b>	Application: Telecom (36-75 VDC Input): 60 W, 12 V Forward Converter (Sync. Rectification)
	<b>DI-53</b>	Application: Telecom (36-75 VDC Input): 50 W, 5 V / 3.3 V Forward Converter (Sync. Rectification)
	<b>DI-56</b>	Application: Telecom (36-75 VDC Input): 19.2 W, ±12 V Flyback Converter
	<b>DI-57</b>	Application: Telecom (36-75 VDC Input): 60 W, 12 V Flyback Converter
	<b>DI-69</b>	Application: VoIP Phone, 15 W, 5 V / 7.5 V / 20 V Forward Converter (Sync. Rectification)
	<b>DI-70</b>	Application: PoE VoIP Phone, 15 W, 5 V / 7.5 V / 20 V Forward Converter (Sync. Rectification)
<b>DI-88</b>	Application: PoE PD Flyback Converter with Programmable Class	

\* Downloadable from [www.powerint.com](http://www.powerint.com)



## Worldwide Sales Support Locations

### World Headquarters

5245 Hellyer Avenue  
San Jose, CA 95138, USA.  
Main: +1 408-414-9200  
Customer Service  
Phone: +1-408-414-9665  
Fax: +1-408-414-9765  
Email: [usasales@powerint.com](mailto:usasales@powerint.com)  
[info@powerint.com](mailto:info@powerint.com)

### Worldwide Applications

Hotline: +1-408-414-9660  
Fax: +1-408-414-9760

### On the Web

[www.powerint.com](http://www.powerint.com)

### China (Shanghai)

Room 1601/1610, Tower 1,  
Kerry Everbright City  
No. 218 Tianmu Road West  
Shanghai, P.R.C. 200070  
Phone: +86-21-6354-6323  
Fax: +86-21-6354-6325  
Email: [chinasales@powerint.com](mailto:chinasales@powerint.com)

### China (Shenzhen)

Room A, B & C 4th Floor, Block C  
Elec. Sci. Tech. Bldg.  
2070 Shennan Zhong Rd.  
Shenzhen, Guangdong, China 518031  
Phone: +86-755-8379-3243  
Fax: +86-755-8379-5828  
Email: [chinasales@powerint.com](mailto:chinasales@powerint.com)

### Germany

Ruckertstrasse 3  
D-80336, Munich  
Germany  
Phone: +49-89-5527-3911  
Fax: +49-89-5527-3920  
Email: [eurosales@powerint.com](mailto:eurosales@powerint.com)

### India

#1, 14th Main Road  
Vasanthanagar  
Bangalore-560052 India  
Phone: +91-80-4113-8020  
Fax: +91-80-4113-8023  
Email: [indiasales@powerint.com](mailto:indiasales@powerint.com)

### Italy

Via De Amicis 2  
20091 Bresso MI  
Italy  
Phone: +39-028-928-6000  
Fax: +39-028-928-6009  
Email: [eurosales@powerint.com](mailto:eurosales@powerint.com)

### Japan

Kosei Dai-3 Bldg.,  
2-12-11, Shin-Yokohama, Kohoku-ku,  
Yokohama-shi, Kanagawa 222-0033  
Phone: +81-45-471-1021  
Fax: +81-45-471-3717  
Email: [japansales@powerint.com](mailto:japansales@powerint.com)

### Korea

RM 602, 6FL  
Korea City Air Terminal B/D, 159-6  
Samsung-Dong, Kangnam-Gu  
Seoul, 135-728, Korea  
Phone: +82-2-2016-6610  
Fax: +82-2-2016-6630  
Email: [koreasales@powerint.com](mailto:koreasales@powerint.com)

### Singapore

51 Newton Road,  
#15-08/10 Goldhill Plaza  
Singapore, 308900  
Phone: +65-6358-2160  
Fax: +65-6358-2015  
Email: [singaporesales@powerint.com](mailto:singaporesales@powerint.com)

### Taiwan

5F, No. 318, Nei Hu Rd., Sec. 1  
Nei Hu Dist.  
Taipei 114, Taiwan R.O.C.  
Phone: +886-2-2659-4570  
Fax: +886-2-2659-4550  
Email: [taiwansales@powerint.com](mailto:taiwansales@powerint.com)

### United Kingdom

1st Floor, St. James's House  
East Street, Farnham  
Surrey, GU9 7TJ  
United Kingdom  
Phone: +44 (0) 1252-730-141  
Fax: +44 (0) 1252-727-689  
Email: [eurosales@powerint.com](mailto:eurosales@powerint.com)





## X-ON Electronics

Largest Supplier of Electrical and Electronic Components

*Click to view similar products for [Power Management IC Development Tools](#) category:*

*Click to view products by [Power Integrations](#) manufacturer:*

Other Similar products are found below :

[EVAL-ADM1168LQEBZ](#) [EVB-EP5348UI](#) [MIC23451-AAAYFL EV](#) [MIC5281YMME EV](#) [DA9063-EVAL](#) [ADP122-3.3-EVALZ](#) [ADP130-0.8-EVALZ](#) [ADP130-1.2-EVALZ](#) [ADP130-1.5-EVALZ](#) [ADP130-1.8-EVALZ](#) [ADP1712-3.3-EVALZ](#) [ADP1714-3.3-EVALZ](#) [ADP1715-3.3-EVALZ](#) [ADP1716-2.5-EVALZ](#) [ADP1740-1.5-EVALZ](#) [ADP1752-1.5-EVALZ](#) [ADP1828LC-EVALZ](#) [ADP1870-0.3-EVALZ](#) [ADP1871-0.6-EVALZ](#) [ADP1873-0.6-EVALZ](#) [ADP1874-0.3-EVALZ](#) [ADP1882-1.0-EVALZ](#) [ADP199CB-EVALZ](#) [ADP2102-1.25-EVALZ](#) [ADP2102-1.875EVALZ](#) [ADP2102-1.8-EVALZ](#) [ADP2102-2-EVALZ](#) [ADP2102-3-EVALZ](#) [ADP2102-4-EVALZ](#) [ADP2106-1.8-EVALZ](#) [ADP2147CB-110EVALZ](#) [AS3606-DB](#) [BQ24010EVM](#) [BQ24075TEVM](#) [BQ24155EVM](#) [BQ24157EVM-697](#) [BQ24160EVM-742](#) [BQ24296MEVM-655](#) [BQ25010EVM](#) [BQ3055EVM](#) [NCV891330PD50GEVB](#) [ISLUSBI2CKIT1Z](#) [LM2744EVAL](#) [LM2854EVAL](#) [LM3658SD-AEV/NOPB](#) [LM3658SDEV/NOPB](#) [LM3691TL-1.8EV/NOPB](#) [LM4510SDEV/NOPB](#) [LM5033SD-EVAL](#) [LP38512TS-1.8EV](#)