

DI-74 Design Idea

LinkSwitch-TN[®]

1.25 W Non-Isolated Constant Current LED Driver

Application	Device	Power Output	Input Voltage	Output Voltage	Topology
LED Driver	LNK304PN	1.25 W	85 – 265 VAC	12.5 V, 100 mA	Buck-Boost

Design Highlights

- Universal AC input range – single design worldwide
- Accurate and stable constant current output
- Small size and weight
- Low cost, low component count solution replaces passive capacitor or resistor droppers
- Fail safe topology – protects load
- High efficiency (>60% at 85 VAC)
- Scalable output power using larger LinkSwitch-TN devices
- Meets EN55022 B EMI limits

Operation

Using the Buck-Boost topology, the circuit shown in Figure 1 generates a non-isolated constant current (CC) output for driving LEDs. Typical uses include night-lights, neon sign replacements, emergency exit signs or any application utilizing LEDs for lighting.

The AC input is rectified and filtered by D1, D2, C1, C2, RF1, and RF2. Two diodes improve both line surge withstand (2 kV) and conducted EMI. Resistor RF1 should be a fusible flameproof type, whereas RF2 can be flameproof only.

LinkSwitch-TN uses ON/OFF control to regulate the output current. When the current into the FEEDBACK (FB) pin exceeds 49 μ A, MOSFET switching is disabled for the next switching cycle. The 49 μ A threshold is specified at a pin voltage of 1.65 V (\pm 7%), allowing it to be used as a reference.

The voltage developed across R3, which is averaged by C4, represents the output current. When this voltage exceeds 2 V, the voltage on the FB pin, via divider of R1 and R2, exceeds 1.65 V and >49 μ A current is fed into the pin. The 2 V across R3 sets an output current of 100 mA, or 25 mA for each string of LEDs. If the load is disconnected or the output is shorted, no feedback is provided and LinkSwitch-TN enters auto-restart (5% on time). To prevent a high output voltage under no load the optional voltage feedback circuit can be included by adding VR1 and D4. The voltage of VR1 is selected to be above the normal output voltage.

Select the value of L1 following AN-37, LinkSwitch-TN Design Guide or using the PIXIs design spreadsheet. Enter the output voltage as the voltage of the LED string and the output current as the total combined LED current.

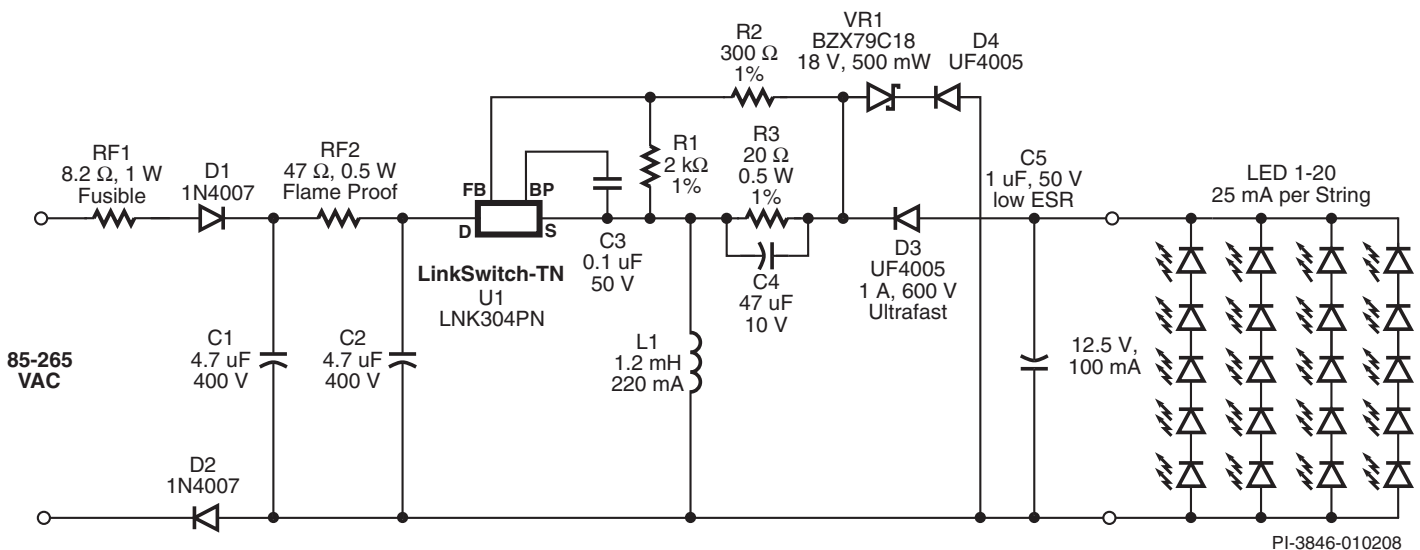

Figure 1. Schematic of a 1.25 W, 12.5 V, 100 mA Constant Current LED Driver, Using a Non-Isolated Buck-Boost Topology.

Key Design Points

- The output is not safety isolated from the input.
- The circuit shown in Figure 1 has a total output current tolerance of $\pm 12\%$ (including Δt of 50 °C).
- To prevent noise coupling and to decrease EMI, place the input filter components physically away from the source node of the LinkSwitch-TN and L1 inductor. The DC input filter capacitors C1 and C2 can be placed, as a barrier, between the AC input and U1/L1.
- Select C4 so that $C4 \geq 20 \cdot (15 \text{ ms} / R3)$, to provide adequate filtering of the current sense voltage. Values above $50 \cdot (15 \text{ ms} / R3)$ will yield little improvement in CC linearity.
- Select C5 based on the acceptable peak current through the LEDs. Larger values of capacitance reduce peak LED current. Typical values are 100 nF to 100 μF , low ESR. With no capacitor the peak output current is equal to the internal current limit of U1.
- With the values of R1 and R2 shown, the value of R3 is calculated by $R3 = 2 \text{ V} / I_o$.
- The supply's total required output current is determined by the number of LED strings in the load, and is limited by the value of L1 and the current limit of U1. For this circuit, the load should be $\leq 100 \text{ mA}$ and $\leq 1.25 \text{ W}$ total.

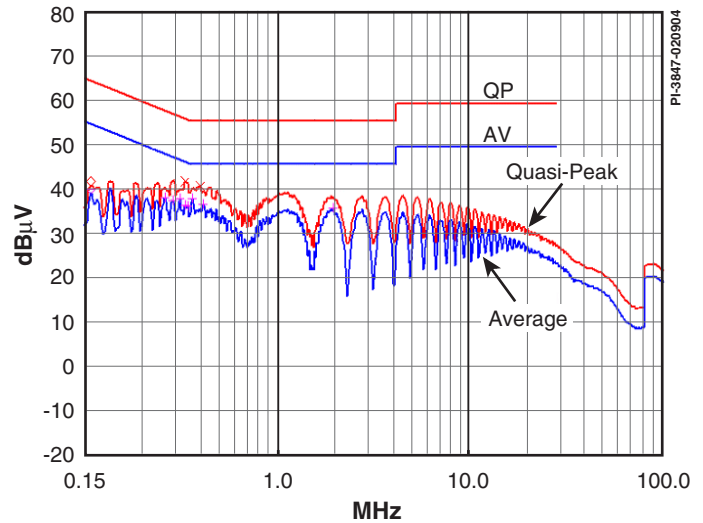

Figure 2. Conducted EMI Plot of the Schematic Shown in Figure 1 for 3 Strings of 4 LED's (10 V, 66.6 mA).

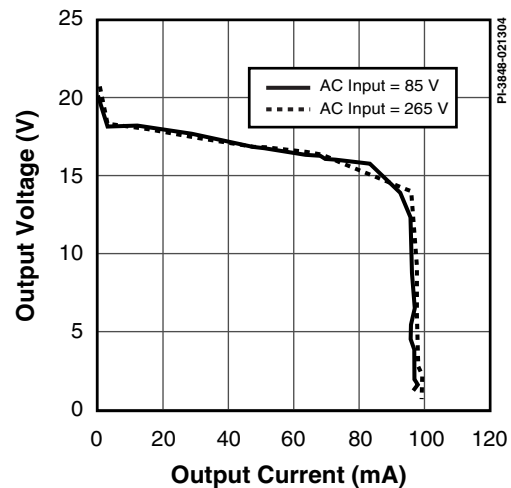

Figure 3. VI Characteristic of the Schematic Shown in Figure 1.

Power Integrations
5245 Hellyer Avenue
San Jose, CA 95138, USA.
Main: +1 408-414-9200
Customer Service
Phone: +1-408-414-9665
Fax: +1-408-414-9765
Email: usasales@powerint.com

On the Web
www.powerint.com

D
1/08

Power Integrations reserves the right to make changes to its products at any time to improve reliability or manufacturability. Power Integrations does not assume any liability arising from the use of any device or circuit described herein. POWER INTEGRATIONS MAKES NO WARRANTY HEREIN AND SPECIFICALLY DISCLAIMS ALL WARRANTIES INCLUDING, WITHOUT LIMITATION, THE IMPLIED WARRANTIES OF MERCHANTABILITY, FITNESS FOR A PARTICULAR PURPOSE, AND NON-INFRINGEMENT OF THIRD PARTY RIGHTS. The products and applications illustrated herein (transformer construction and circuits external to the products) may be covered by one or more U.S. and foreign patents or potentially by pending U.S. and foreign patent applications assigned to Power Integrations. A complete list of Power Integrations' patents may be found at www.powerint.com. Power Integrations grants its customers a license under certain patent rights as set forth at <http://www.powerint.com/ip.htm>.

The PI logo, TOPSwitch, TinySwitch, LinkSwitch, DPA-Switch, PeakSwitch, EcoSmart, Clampless, E-Shield, Filterfuse, StackFET, PI Expert and PI FACTS are trademarks of Power Integrations, Inc. Other trademarks are property of their respective companies. ©2006, Power Integrations, Inc.

X-ON Electronics

Largest Supplier of Electrical and Electronic Components

Click to view similar products for [AC/DC Converters](#) category:

Click to view products by [Power Integrations](#) manufacturer:

Other Similar products are found below :

[BP5722A12](#) [ICE3AR0680VJZ](#) [ICE3AR2280CJZ](#) [ICE3BR0680JZ](#) [ICE3BR2280JZ](#) [SEA01](#) [FAN7621SSJX](#) [BP5011](#) [BP5055-12](#) [BP5718A12](#)
[ICE2QR4780Z](#) [NCP1124BP100G](#) [AP3983EP7-G1](#) [ICE2QR4765](#) [TEA19363T/1J](#) [AP3125CMKTR-G1](#) [ICE3AR10080CJZ](#) [SC1076P065G](#)
[47132](#) [47220](#) [47225](#) [APR3415BMTR-G1](#) [NCP1126BP100G](#) [HF500GP-40](#) [TNY179PN](#) [ICE3AR10080JZXKLA1](#) [BM2P0361-Z](#)
[BM2P249Q-Z](#) [BM521Q25F-GE2](#) [INN3164C-H107-TL](#) [HR1001CGS-P](#) [HR1001LGS-P](#) [BM2P131X-Z](#) [BM2P161X-Z](#) [BM2P181X-Z](#)
[BM2P201X-Z](#) [BM2P241X-Z](#) [LNK576DG-TL](#) [INN3278C-H215-TL](#) [INN3278C-H217-TL](#) [INN3678C-H605-TL](#) [NCP1342BMDCCDD1R2G](#)
[AP3304AW6-7](#) [TNY263PN](#) [TNY286PG](#) [TNY287PG](#) [TNY288DG-TL](#) [TNY288PG](#) [MP100GN](#) [BP5034D24](#)