

Multi-Phase Power Inductors

CL1108 & CLA1108 Series



SMD Device

Description

- Halogen free, lead free and RoHS compliant
- CLA Series features acoustic noise dampening properties
- Designed exclusively for use with Volterra VPR-Devices^A
- High current multi-phase inductor applications
- Ferrite core material
- 50nH per phase coupled inductor
- 125°C maximum temperature operation
- Patents pending

Applications

- For exclusive use with Volterra[®] VPR-Devices

Environmental Data

- Storage temperature range: -40°C to +125°C
- Operating temperature range: -40°C to +125°C (range is application specific)
- Solder reflow temperature: J-STD-020D compliant

Packaging

- Supplied in tape and reel packaging on a 13" diameter reel:

Series/ Part Number	Reel Quantity
CL/CLA1108-2	500
CL/CLA1108-3	500
CL/CLA1108-4	400
CL1108-5	300

A This device is licensed for use only when incorporated within a voltage regulator employing power regulating devices manufactured by Volterra Semiconductor Corp. No license is granted expressly or by implication to use this device with power regulating devices manufactured by any company other than Volterra.

Specifications

Functional						Test				
Part Number ⁴	Inductor Phases	DCR (mΩ) ±10% @20°C	Rated Inductance per Phase (nH) ³	I Rated per Phase (A _{dc}) ³	I _{max} Peak per Phase (A _{dc}) ³	Pin Number	OCL (nH) ^{1,2}	Pin Number	OCL (nH) ^{1,2}	Magnetized Inductance (nH) @ 10A _{dc} (25°C)
CL1108 Standard Series										
CL1108-2-50TR-R	2	0.28	50±20%	50	80	(3-4)	380±20%	(1-2)	380±20%	300
CL1108-3-50TR-R	3	0.28	50±20%	50	80	(3-4)	400±20%	(1-2), (5-6)	380±20%	300
CL1108-4-50TR-R	4	0.28	50±20%	50	80	(3-4), (5-6)	400±20%	(1-2), (7-8)	380±20%	300
CL1108-5-50TR-R	5	0.28	50±20%	50	80	(3-4), (5-6), (7-8)	400 ±20%	(1-2), (9-10)	380±20%	300
CLA1108 Acoustic Series										
CLA1108-2-50TR-R	2	0.28	50 ± 20%	50	80	(3-4)	380 ±20%	(1-2)	380 ±20%	300
CLA1108-3-50TR-R	3	0.28	50 ± 20%	50	80	(3-4)	400 ±20%	(1-2), (5-6)	380 ±20%	300
CLA1108-4-50TR-R	4	0.28	50 ± 20%	50	80	(3-4), (5-6)	400 ±20%	(1-2), (7-8)	380 ±20%	300

1. Open Circuit Inductance (OCL)

2. Test Parameters: 1MHz, 0.1V_{rms}, 0.0A_{dc}.

3. The rated current, I_{max} peak current, and rated inductance per phase is determined by Volterra's testing and circuit design. Additional information can be provided by contacting Volterra.

4. Part Number Definition: CLx1108-y-50TR-R

- CL(x)1108 = Product code and size

(CL prefix = standard, CLA prefix = with Acoustic Dampening)

- "y" = number of phases

- "50" = inductance value per phase nH

- "TR" = Tape and Reel packaging

- "-R" suffix = RoHS compliant

Dimensions - mm

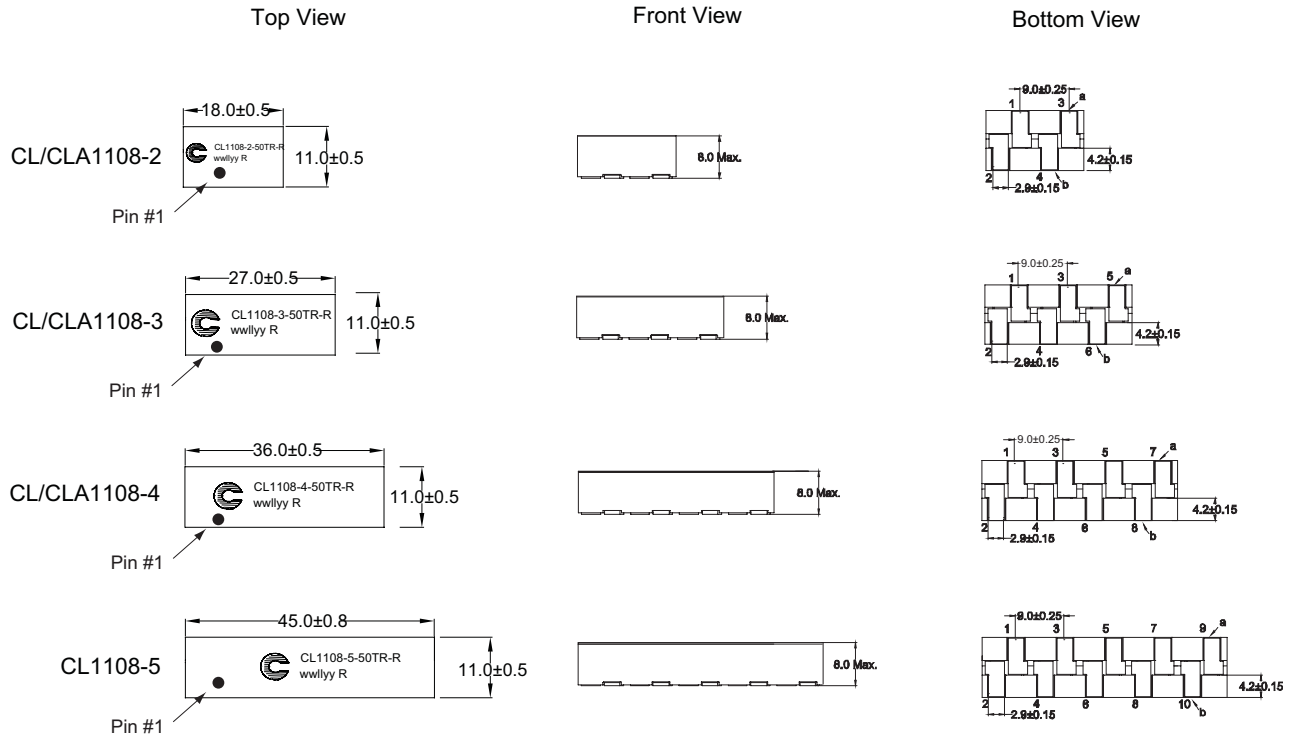

DCR measured from point 'a' to point 'b'

Part Marking: Coiltronics Logo, CLx1108 = Product Code and Size (CL = standard, CLA = acoustic dampening), -y (-3, -4) = Number of phases, -50 = inductance value per phase, TR = Tape and Reel, wwlyyy = Date Code, R = Revision Level.

Pad Layouts & Schematics- mm

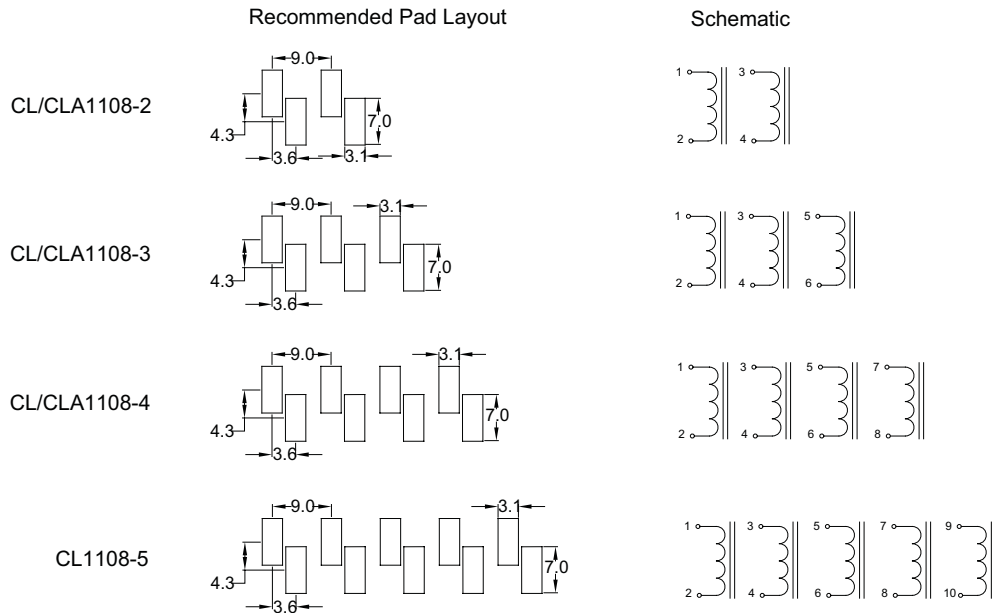

Packaging Information - mm

CL/CLA1108-2
500 parts per reel

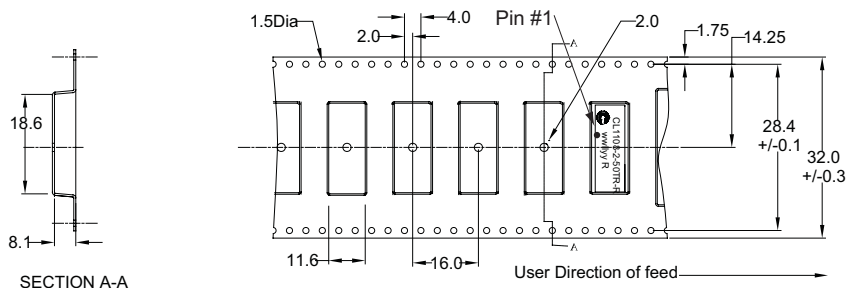

SECTION A-A

CL/CLA1108-3
500 parts per reel

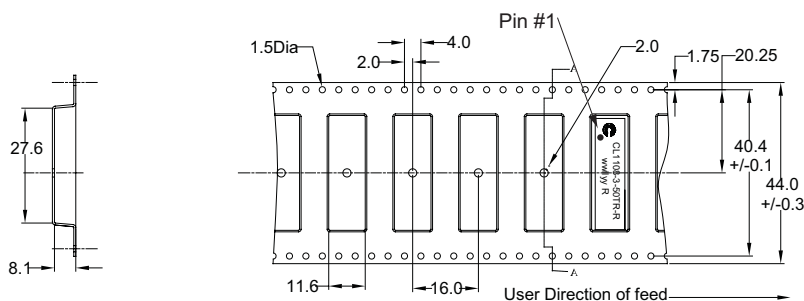

SECTION A-A

CL/CLA1108-4
400 parts per reel

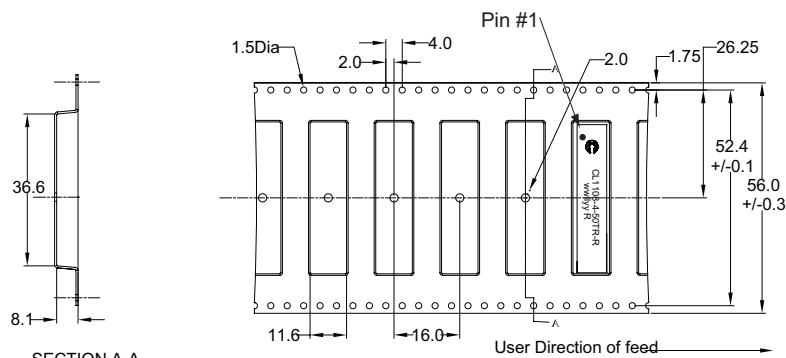

SECTION A-A

CL1108-5
300 parts per reel

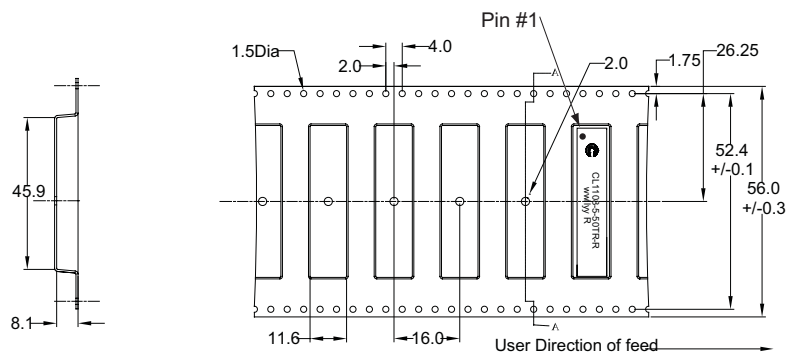

SECTION A-A

Supplied in tape and reel packaging on a 13" diameter reel in the part number quantities shown above.

Solder Reflow Profile

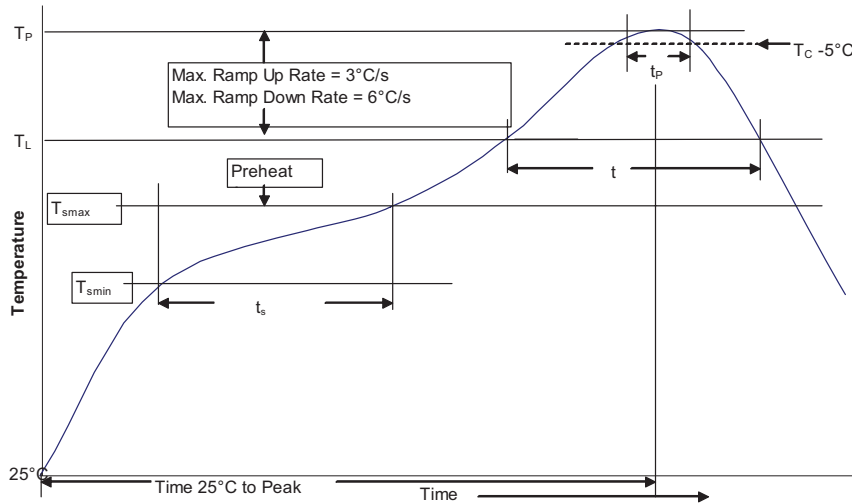

Table 1 - Standard SnPb Solder (T_C)

Package Thickness	Volume mm^3 <350	Volume mm^3 ≥ 350
<2.5mm	235°C	220°C
$\geq 2.5mm$	220°C	220°C

Table 2 - Lead (Pb) Free Solder (T_C)

Package Thickness	Volume mm^3 <350	Volume mm^3 350 - 2000	Volume mm^3 >2000
<1.6mm	260°C	260°C	260°C
1.6 - 2.5mm	260°C	250°C	245°C
>2.5mm	250°C	245°C	245°C

Reference JDEC J-STD-020D

Profile Feature	Standard SnPb Solder	Lead (Pb) Free Solder
Preheat and Soak		
• Temperature min. (T_{smin})	100°C	150°C
• Temperature max. (T_{smax})	150°C	200°C
• Time (T_{smin} to T_{smax}) (t_s)	60-120 Seconds	60-120 Seconds
Average ramp up rate T_{smax} to T_P	3°C/ Second Max.	3°C/ Second Max.
Liquidous temperature (T_L)	183°C	217°C
Time at liquidous (t_L)	60-150 Seconds	60-150 Seconds
Peak package body temperature (T_P)*	Table 1	Table 2
Time (t_p)** within 5 °C of the specified classification temperature (T_C)	20 Seconds**	30 Seconds**
Average ramp-down rate (T_P to T_{smax})	6°C/ Second Max.	6°C/ Second Max.
Time 25°C to Peak Temperature	6 Minutes Max.	8 Minutes Max.

* Tolerance for peak profile temperature (T_P) is defined as a supplier minimum and a user maximum.

** Tolerance for time at peak profile temperature (t_p) is defined as a supplier minimum and a user maximum.

North America

Cooper Electronic Technologies
1225 Broken Sound Parkway NW
Suite F
Boca Raton, FL 33487-3533
Tel: 1-561-998-4100
Fax: 1-561-241-6640
Toll Free: 1-888-414-2645

Cooper Bussmann
P.O. Box 14460
St. Louis, MO 63178-4460
Tel: 1-636-394-2877
Fax: 1-636-527-1607

Europe

Cooper Electronic Technologies
Cooper (UK) Limited
Burton-on-the-Wolds
Leicestershire • LE12 5TH UK
Tel: +44 (0) 1509 882 737
Fax: +44 (0) 1509 882 786

Cooper Electronic Technologies
Avda. Santa Eulalia, 290
08223
Terrassa, (Barcelona), Spain
Tel: +34 937 362 812
+34 937 362 813
Fax: +34 937 362 719

Asia Pacific

Cooper Electronic Technologies
1 Jalan Kilang Timor
#06-01 Pacific Tech Centre
Singapore 159303
Tel: +65 278 6151
Fax: +65 270 4160

The only controlled copy of this Data Sheet is the electronic read-only version located on the Cooper Bussmann Network Drive. All other copies of this document are by definition uncontrolled. This bulletin is intended to clearly present comprehensive product data and provide technical information that will help the end user with design applications. Cooper Bussmann reserves the right, without notice, to change design or construction of any products and to discontinue or limit distribution of any products. Cooper Bussmann also reserves the right to change or update, without notice, any technical information contained in this bulletin. Once a product has been selected, it should be tested by the user in all possible applications.

Life Support Policy: Cooper Bussmann does not authorize the use of any of its products for use in life support devices or systems without the express written approval of an officer of the Company. Life support systems are devices which support or sustain life, and whose failure to perform, when properly used in accordance with instructions for use provided in the labeling, can be reasonably expected to result in significant injury to the user.

X-ON Electronics

Largest Supplier of Electrical and Electronic Components

Click to view similar products for [Coupled Inductors](#) category:

Click to view products by [PowerStor](#) manufacturer:

Other Similar products are found below :

[NPIS48LS1R0YTRF](#) [NPIS21LS2R2MTRF](#) [NIN-HCR27JTRF](#) [744874470](#) [CPL-4-50TR-R](#) [CTX20-1A-R](#) [CL1208-2-100TR-R](#) [SDQ25-470-R](#)
[LPD5030-153MRC](#) [LPD5030-105MRC](#) [MSD1260-154KLD](#) [MSD1260-224KLD](#) [MSD1260-474KLD](#) [MSD1260-472MLD](#) [MSD1260-103MLD](#) [MSD1260-153MLD](#) [MSD1278-154KLD](#) [MSD1583-103MED](#) [MSD1583-223MED](#) [MSD1583-683MED](#) [MSD7342-224MLC](#)
[MSD7342-824MLC](#) [PFD3215-103MEC](#) [LPD3015-332MRC](#) [LPD3015-223MRC](#) [LPD3015-104MRC](#) [LPD4012-223MRC](#) [LPD4012-331NRC](#)
[LPD5010-822MRC](#) [LPD6235-155MRC](#) [MSD1514-224KED](#) [MSD1514-472MED](#) [MSD1260-473MLD](#) [MSD1260-683MLD](#) [B82477D4223M](#)
[CTX8-1-R](#) [CTX16-17769-R](#) [HM78D-1210680MLFTR](#) [CTX150-4A-R](#) [CL-12-24](#) [47330C](#) [47220C](#) [74485540101](#) [7023](#) [PM3602-25-RC](#)
[PM3602-100-RC](#) [PM3602-5-RC](#) [PM3602-200-RC](#) [PM3602-20-RC](#) [PM3602-250-RC](#)