

Features

- Complete Module:
 - Projected Capacitive Multi Touch Controller
 - 2.8in LCD
- Touch:
 - Atmel maXTouch mXT143E Touch Controller
 - Supports up to 8 touches
- Display:
 - Displaytech SDT028ATFT 2.8in LCD
 - 320x240 resolution
 - 20 ms typical response time
 - SPI interface via ILI9341 / ILI9320 (or compatible)
 - Optional support for 18-bit parallel interface
 - White LED backlight
- Cover Panel:
 - 1.2mm Soda Lime Glass
 - Optional 0.7mm Gorilla Glass™



PDA TM2800: 2.8in PCAP Touch Module – Atmel Xplained Configuration

1305-4-4



Contents

1	Module Overview	4
1.1	PCB Connections	4
1.2	Debug Connector J1	5
1.3	Touch Sensor Flex Connector J2	5
1.4	Display Flex Connector J3	6
1.5	Host Connector J4	7
2	Overview of the 2.8in PCAP Touch Module – Atmel Xplained Configuration	8
2.1	Introduction	8
2.2	Understanding Unfamiliar Concepts	9
2.3	LCD Panel	9
2.4	maXTouch Capacitive Touchscreen Controller	9
2.4.1	maXTouch Controller Interface	9
3	Getting Started - Atmel Xplained	11
3.1	Hardware Connection	11
3.2	Loading Example Code	12
3.2.1	Programming Tools	12
3.2.2	Programming the Example Code	12
3.2.3	Using the Touch Module	12
4	Specifications	13
4.1	Mechanical Specifications	13
4.2	Absolute Maximum Specifications	14
4.3	Recommended Operating Conditions	15
4.4	DC Specifications	15
4.5	I2C-compatible Bus Specifications	15
4.6	Power Consumption	15
4.7	Part Number	15
5	I2C Basics (I2C-compatible Operation)	16
5.1	Interface Bus	16
5.2	Transferring Data Bits	16
5.3	START and STOP Conditions	16
5.4	Address Byte Format	17
5.5	Data Byte Format	17
5.6	Combining Address and Data Bytes into a Transmission	18

6	Revision History	19
7	Notes	20

1 Module Overview

1.1 PCB Connections

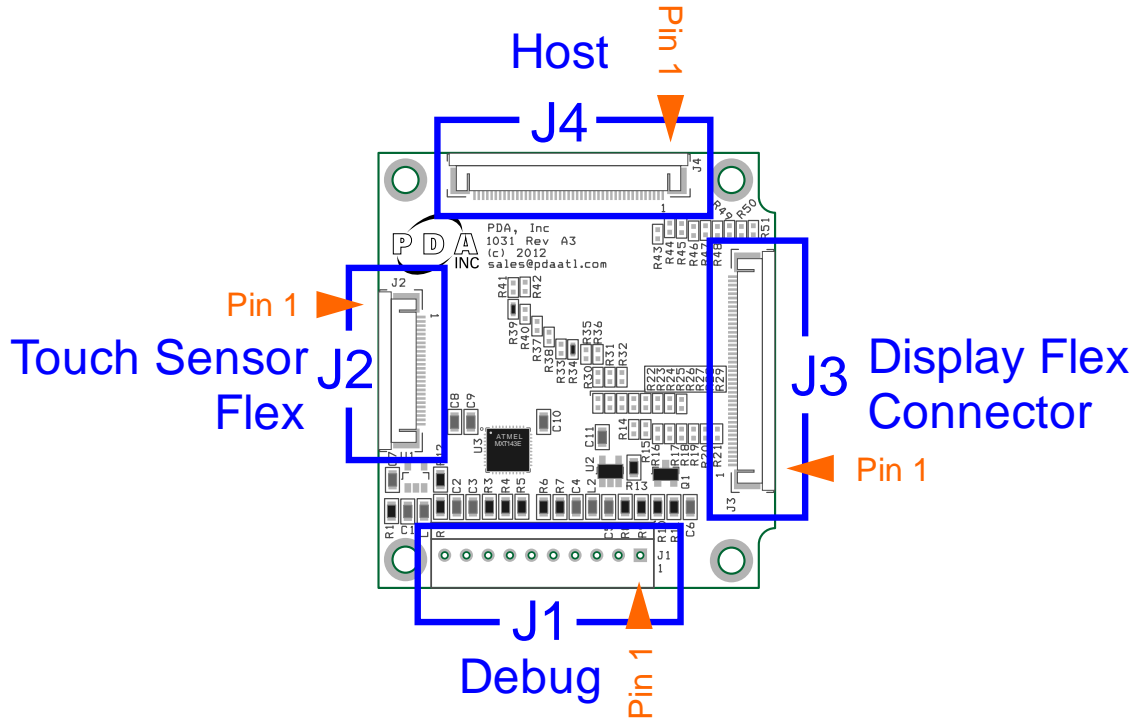

Figure 1 - PCB Connectors

The following notations are used for pin descriptions. Note signal direction is given *with respect to the touch module* – not the device connected:

MXT	maXTouch touchscreen	LCD	LCD Panel
I	Input only	OD	Open drain output
O	Output only, push-pull	P	Ground or Power

1.2 Debug Connector J1

Connector J1 carries signals used to debug the MaXTouch Touchscreen Controller.

Pin	Type	Description
1	P	+5Vdc
2	-	N/C
3	O	~MXT_CHG
4	-	N/C
5	I	I ² C SDA

Pin	Type	Description
6	I/O	I ² C SCL
7	-	N/C
8	P	GND
9	O	MXT DBG DATA
10	O	MXT DBG CLK

1.3 Touch Sensor Flex Connector J2

Connector J2 connects to the touch sensor flex and carries signals used by the maXTouch controller to detect input on the touch sensor.

Pin	Type	Description
1	I/O	X1
2	I/O	X3
3	I/O	X5
4	I/O	X7
5	I/O	X9
6	I/O	X11
7	P	GND
8	I/O	Y0
9	I/O	Y1
10	I/O	Y2
11	I/O	Y3
12	I/O	Y4
13	I/O	Y5

Pin	Type	Description
14	I/O	Y6
15	I/O	Y7
16	I/O	Y8
17	I/O	Y9
18	I/O	Y10
19	P	GND
20	I/O	X12
21	I/O	X10
22	I/O	X8
23	I/O	X6
24	I/O	X4
25	I/O	X2
26	I/O	X0

1.4 Display Flex Connector J3

Connector J3 connects to the LCD panel flex and carries signals between the host and the LCD panel.

Pin	Type	Description
1	P	Vdd
2	P	LED_K1 (Backlight Cathode)
3	P	LED_K2 (Backlight Cathode)
4	P	LED_K3 (Backlight Cathode)
5	P	LED_K4 (Backlight Cathode)
6	O	IM0
7	O	IM1
8	O	IM2
9	O	IM3
10	I	FMARK
11	O	VSYNC
12	O	HSYNC
13	O	DOTCLK
14	O	ENABLE
15	I/O	DB17
16	I/O	DB16
17	I/O	DB15
18	I/O	DB14
19	I/O	DB13
20	I/O	DB12
21	I/O	DB11
22	I/O	DB10
23	I/O	DB9

Pin	Type	Description
24	I/O	DB8
25	I/O	DB7
26	I/O	DB6
27	I/O	DB5
28	I/O	DB4
29	I/O	DB3
30	I/O	DB2
31	I/O	DB1
32	I/O	DB0
33	O	~CS
34	O	WR
35	O	RS / SCL
36	O	RD
37	O	RESET
38	I	SDO
39	O	SDI
40	P	Vcc
41	P	GND
42	-	N/C
43	-	N/C
44	-	N/C
45	-	N/C

1.5 Host Connector J4

Connector J1 connects to the host and carries signals between the host and (1) the MaXTouch Touch Controller and (2) LCD Panel.

Pin	Type	Description	MXT	LCD
1	I	LED_EN		•
2	O	LED-		•
3	I	SYNC	•	
4	-	N/C		
5	-	N/C		
6	I	IM0		•
7	I	IM1		•
8	I	IM2		•
9	I	IM3		•
10	O	FMARK		•
11	I	VSYNC		•
12	I	HSYNC		•
13	I	DOTCLK		•
14	I	ENABLE		•
15	I/O	DB17		•
16	I/O	DB16		•
17	I/O	DB15		•
18	I/O	DB14		•
19	I/O	DB13		•
20	I/O	DB12		•
21	I/O	DB11		•
22	I/O	DB10		•
23	I/O	DB9		•

Pin	Type	Description	MXT	LCD
24	I/O	DB8		•
25	I/O	DB7		•
26	I/O	DB6		•
27	I/O	DB5		•
28	I/O	DB4		•
29	I/O	DB3		•
30	I/O	DB2		•
31	I/O	DB1		•
32	I/O	DB0		•
33	I	~CS		•
34	I	WR		•
35	I	RS / SCL		•
36	I	RD		•
37	I	RESET		•
38	O	SDO		•
39	I	SDI		•
40	P	Vin		
41	P	GND		
42	I	~MXT_RESET	•	
43	O	~MXT_CHG	•	
44	I/O	I ² C SDA	•	
45	I	I ² C SCL	•	

NOTE: The host connector can support interfacing with the LCD panel via serial or parallel interface. Refer to the display panel datasheet s (see Section 2.2) for instructions on properly connecting unused signals if the touch module is used with hardware other than the Atmel Xplained MCU and Routing Board.

2 Overview of the 2.8in PCAP Touch Module – Atmel Xplained Configuration

2.1 Introduction

The 2.8in PCAP Touch Module – Atmel Xplained Configuration is a touchscreen module offering best-in-class projected capacitance multi-touch functionality combined with a 2.8in LCD panel. The module is configured for development and evaluation with Atmel Xplained MCU solutions as well as development and integration with a custom host system.

For convenience, this module features a host interface flex connector positioned for interfacing with an Atmel Xplained Routing Board.

As shown in Figure 2 below, the module provides host access to the touchscreen controller and display interface for easy integration.

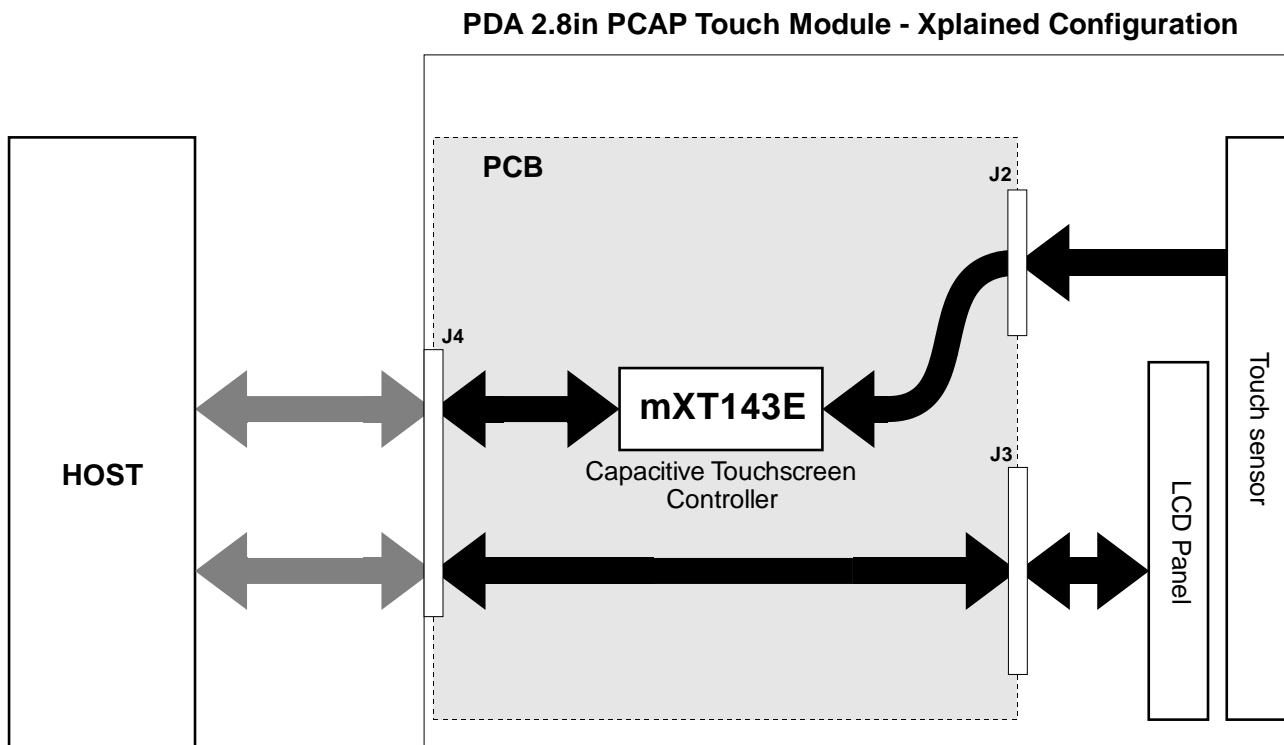

Figure 2 - Functional Block Diagram

2.2 Understanding Unfamiliar Concepts

Throughout this document, the functionality of the module sub-system will be outlined and summarized. However, the user is encouraged to refer to the resources and documents below in order to gain a more thorough understanding of each sub-system.

- For a basic overview of I²C communication, refer to [Section 5](#) of this document
- Displaytech SDT028ATFT Datasheet (www.displaytech-us.com)
- Atmel Application Note AVR32963: mXT143E Xplained Hardware Guide (www.atmel.com)
- Atmel maXTouch mXT143E Datasheet (www.atmel.com)

2.3 LCD Panel

The module provides the host with a direct connection from the host ([Connector J4](#)) to the LCD panel interface ([Connector J3](#)). Aside from generating supply voltages for the LED backlight and providing backlight control to the host, no control of the display panel is performed by the module.

2.4 maXTouch Capacitive Touchscreen Controller

The module touch screen interface is based on the Atmel maXTouch mXT143E Touch Controller.

The touch controller scans the touch sensor and will signal the host with an active low interrupt signal ([Connector J4-43 ~CHG](#)) when new touch data is available. Data communication with the maXTouch controller is performed over a shared I²C interface ([Connector J4-45 SCL](#) and [J4-44 SDA](#)). The I²C address of the touch controller is set to 0x4A.

NOTE: Pull-up resistors for the I²C SCL and SDA lines are located at R5 and R4 respectively. A pull-up resistor for the ~MXT_CHG interrupt signal is located at R7.

2.4.1 maXTouch Controller Interface

Details of the maXTouch communication protocol are beyond the scope of this document. However information is provided below to facilitate evaluation and initial development.



The module is pre-loaded with a configuration already optimized for this touch sensor and panel, so the developer need only focus on interfacing with the device. When developing the maXTouch controller interface during evaluation and host development, care should be taken to avoid changing the maXTouch configuration or committing changes to NV storage on the maXTouch controller.

To get started with host interface development, the user is *strongly* encouraged to leverage existing code available from the resources outlined in the following sections.

2.4.1.1 Atmel Software Framework

The Atmel Software Framework (<http://asf.atmel.com>) contains examples of code for interfacing with devices in the maXTouch family of touch controllers. Many of the code examples found in the ASF are targeted for this maXTouch Xplained module.

2.4.1.2 Linux Kernel / Android

While the Linux or Android OS may not be applicable to all of the Atmel Xplained MCU Boards, there is a growing code base in the Linux and Android communities that can interface with maXTouch touchscreen controllers.

The Linux Kernel (www.kernel.org) has included basic support for maXTouch devices since version 2.6.36. The mainline driver has undergone considerable evolution since then.

In addition, Atmel maintains patches (www.github.com/atmel-maxtouch/linux) which provide numerous out-of-cycle improvements to the mainline Linux Kernel driver.

3 Getting Started - Atmel Xplained

This module was designed to install on a variety of Atmel Xplained MCU boards via an mXT143E Xplained Routing Board. This configuration provides the fastest way to evaluate the performance of the touchscreen and display using Atmel Studio and example code and projects available in the Atmel Software Framework (ASF). The following sections will outline the process of installing the module on a XMEGA-A3BU Xplained.

As noted in section 2.2, the user should refer to Atmel Application Note AVR32963: mXT143E Xplained Hardware Guide (www.atmel.com) for additional details on using this module with an Atmel Xplained MCU board.

3.1 Hardware Connection

The module interfaces with the Xplained MCU board using connector [J4](#) through a flex cable connector to the Atmel mXT143E Xplained Routing board. The Xplained Routing Board in turn, connects to the Atmel Xplained MCU board through connectors J1, J2, J3 and J4.

Both boards have matching connectors: J1 on the Xplained Routing board connects to J1 on the Xplained MCU board, etc. Also, both boards have a corner mounting hole that is marked with a white square. The boards should be oriented so that the marked mounting hole is in the same corner.

Disconnect power / USB from the Xplained MCU board before installing the touch module as shown below in Figure 3.

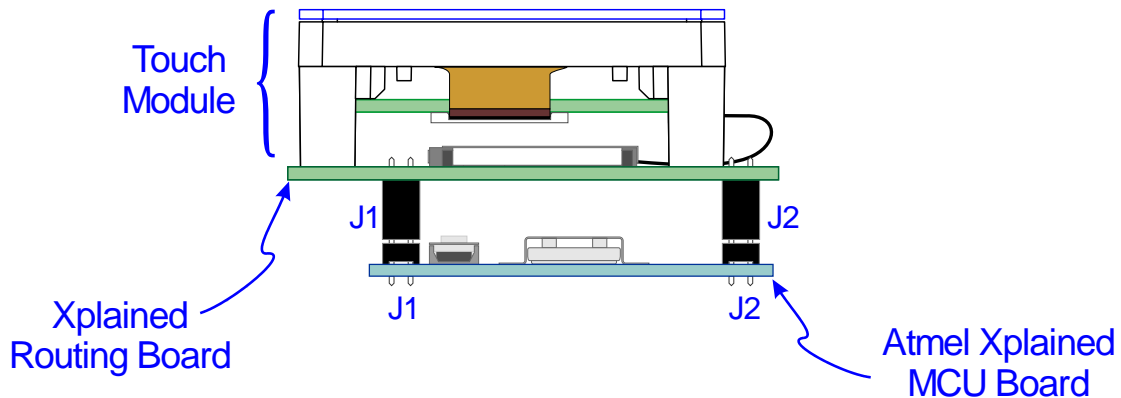

Figure 3 – Connecting the module to the Xplained MCU Board

Note: that the flex cable connecting the module to the mXT143E Xplained Routing board should be inserted into each connector with the FPC contacts facing the respective board. See the illustration in Figure 4 below for more detail.

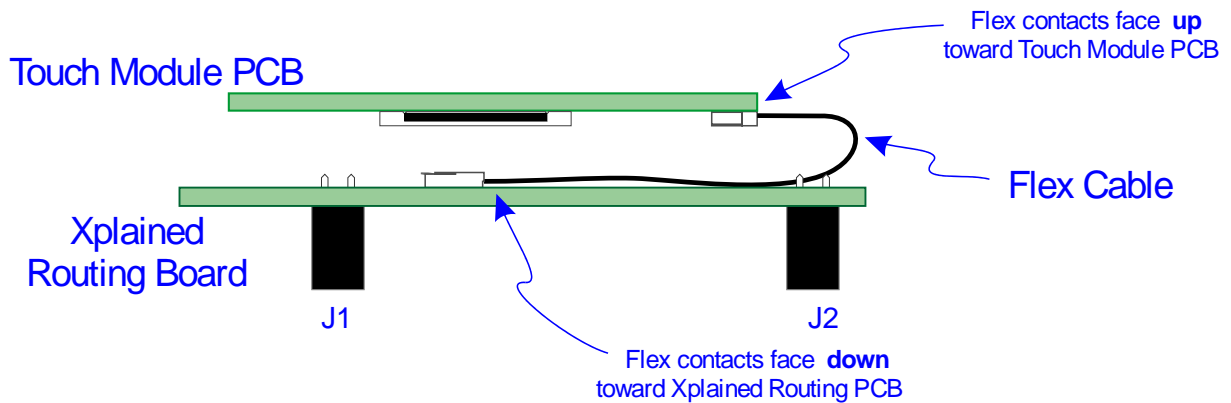

Figure 4 – Flex Connection

3.2 Loading Example Code

The user is encouraged to experiment with the various sample projects available in the Atmel Software Framework (<http://asf.atmel.com>). In order to demonstrate the complete functionality of the module, several of the example projects from the ASF have been compiled for the XMEGA-A3BU Xplained MCU board and binary images (HEX files) are available for download from the PDA website. See details below.

3.2.1 Programming Tools

Before the example HEX files can be loaded, you must first ensure that the necessary programmer driver/software is installed on your development system. Consult the manual and/or support resources for your programmer for instructions on installation and use.

3.2.2 Programming the Example Code

Download the example HEX files from <http://www.pdaatl.com/modules/2.8in/mxt143xplained.zip> and unzip to a working folder. Files are named according to the example project.

3.2.3 Using the Touch Module

Unless noted otherwise, these example HEX files have been compiled for XMega MCU communicating with the display using USART in SPI mode – ensure that the SPI Mode Switch on the mxT143E Xplained Routing board is set to “XMEGA USART in SPI mode”

4 Specifications

For complete specifications, refer to the datasheets listed in section 2.2 for the various sub-system components outlined in Sections 2.3 and 2.4.

4.1 Mechanical Specifications

Drawings and CAD models available upon request.

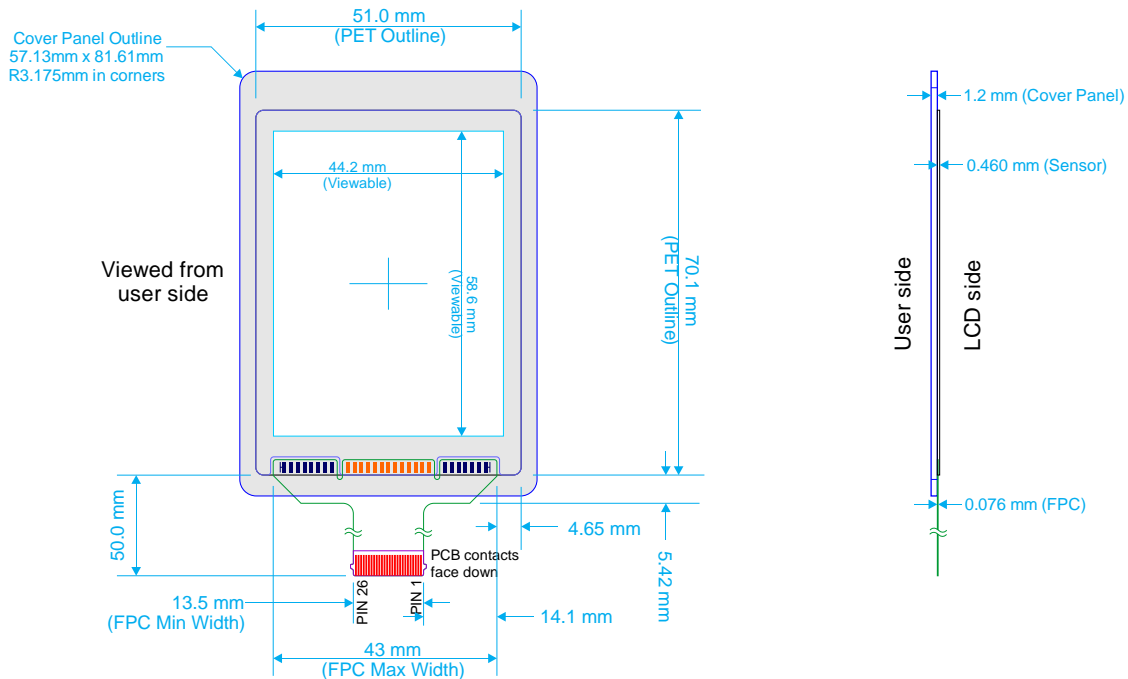

Figure 5 - Sensor Only Dimensions

Sensor (P/N: 21-00001-A0) may be purchased individually.
Minimum order quantities apply. Contact PDA for details.

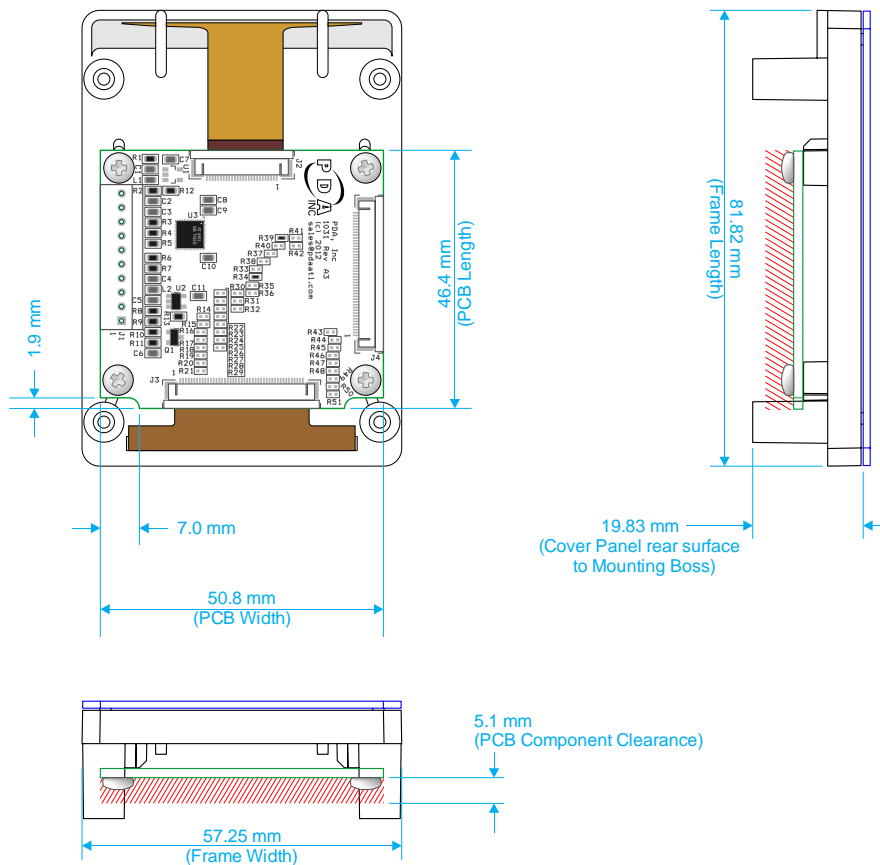

Figure 6 – Module Dimensions

4.2 Absolute Maximum Specifications

Parameter	Value
Operating temp	0°C to +70°C
Storage temp	-40°C to +85°C
Vdd	-0.5 to +3.6V
Max continuous pin current, any control or drive pin	±40 mA
Voltage forced onto any pin	-0.5V to (Vdd + 0.5) Volts



CAUTION: Stresses beyond those listed under *Absolute Maximum Specifications* may cause permanent damage to the device. This is a stress rating only and functional operation of the device at these or other conditions beyond those indicated in the operational sections of this specification are not implied. Exposure to absolute maximum specification conditions for extended periods may affect device reliability.

4.3 Recommended Operating Conditions

Parameter	Value
V _{in}	3.3V ±5 percent
Supply ripple + noise	±20 mV

4.4 DC Specifications

V_{dd} = 3.3, T_a = recommended range, unless otherwise noted

Parameter	Description	Min	Typ	Max	Units	Notes
V _{IL}	Low input logic level	- 0.5	–	0.3 V _{dd}	V	
V _{HL}	High input logic level	0.7 V _{dd}	–	V _{dd} + 0.5	V	
V _{OL}	Low output voltage	–	–	0.2V _{dd}	V	
V _{OH}	High output voltage	0.8V _{dd}	–	–	V	
I _{IL}	Input leakage current	–	–	1	µA	

4.5 I2C-compatible Bus Specifications

Parameter	Operation
Address	0x4A
Maximum bus speed (SCL)	400 kHz
I2C Specification	Version 2.1

4.6 Power Consumption

V _{dd} (V)	Mode	I _{dd} (mA)
3.3V _{dc}	mxt143E in free run and LCD backlight ON full.	60ma

4.7 Part Number

Part Number	Description
90-00001-A0	2.8" Touchscreen Module For Atmel mXT143E Xplained

5 I2C Basics (I2C-compatible Operation)

5.1 Interface Bus

The device communicates with the host over an I²C-compatible bus, in accordance with version 2.1 of the I²C specification. The following sections give an overview of the bus; more detailed information is available from www.i2c-bus.org. Devices are connected to the I²C-compatible bus as shown in Figure 7 both bus lines are connected to Vdd via pull-up resistors. The bus drivers of all I²C-compatible devices must be open-drain type. This implements a wired “AND” function that allows any and all devices to drive the bus, one at a time. A low level on the bus is generated when a device outputs a zero.

Figure 7. I²C-compatible Interface Bus

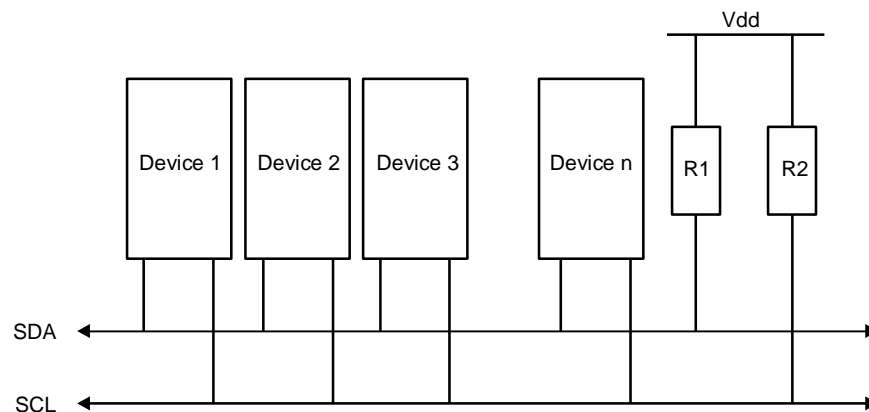

5.2 Transferring Data Bits

Each data bit transferred on the bus is accompanied by a pulse on the clock line. The level of the data line must be stable when the clock line is high; the only exception to this rule is for generating START and STOP conditions.

Figure 8. Data Transfer

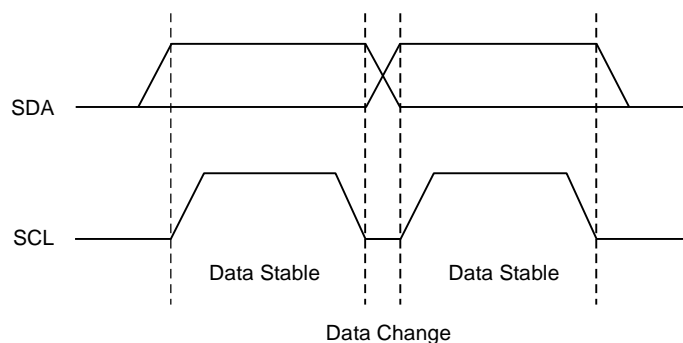

5.3 START and STOP Conditions

The host initiates and terminates a data transmission. The transmission is initiated when the host issues a START condition on the bus, and is terminated when the host issues a STOP condition. Between the START and STOP conditions, the bus is considered busy. As shown in Figure 9 START and STOP conditions are signaled by changing the level of the SDA line when the SCL line is high.

Figure 9. START and STOP Conditions

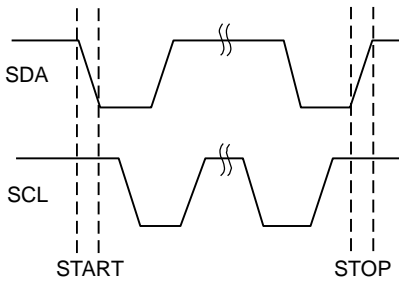

5.4 Address Byte Format

All address bytes are 9 bits long. They consist of 7 address bits, one READ/WRITE control bit and an acknowledge bit. If the READ/WRITE bit is set, a read operation is performed. Otherwise a write operation is performed. An address byte consisting of a slave address and a READ or a WRITE bit is called SLA+R or SLA+W, respectively. When the device recognizes that it is being addressed, it acknowledges by pulling SDA low in the ninth SCL (ACK) cycle.

The most significant bit of the address byte is transmitted first.

Figure 10. Address Byte Format

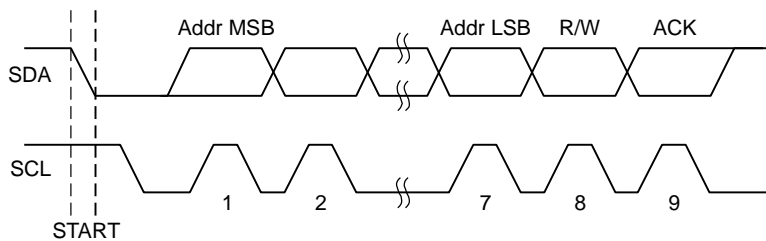

5.5 Data Byte Format

All data bytes are 9 bits long, consisting of 8 data bits and an acknowledge bit. During a data transfer, the host generates the clock and the START and STOP conditions. The slave device is responsible for acknowledging the reception. An acknowledge (ACK) is signaled by the slave device pulling the SDA line low during the ninth SCL cycle. If the slave device leaves the SDA line high, a NACK is signaled.

Figure 11. Data Byte Format

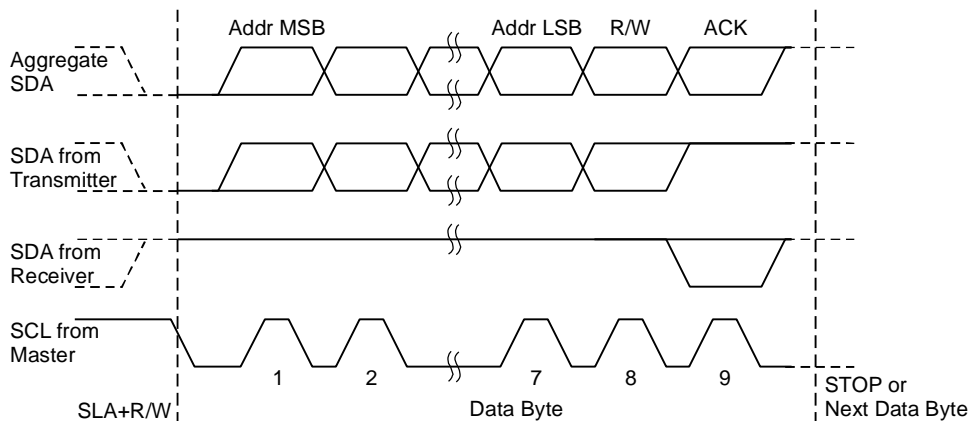

5.6 Combining Address and Data Bytes into a Transmission

A transmission consists of a START condition, an SLA+R or SLA+W, one or more data bytes and a STOP condition. The wired “ANDing” of the SCL line is used to implement handshaking between the host and the device. The device extends the SCL low period by pulling the SCL line low whenever it needs extra time for processing between the data transmissions.

Figure 12 shows a typical data transmission. Note that several data bytes can be transmitted between the SLA+R or SLA+W and the STOP.

Figure 12. Byte Transmission

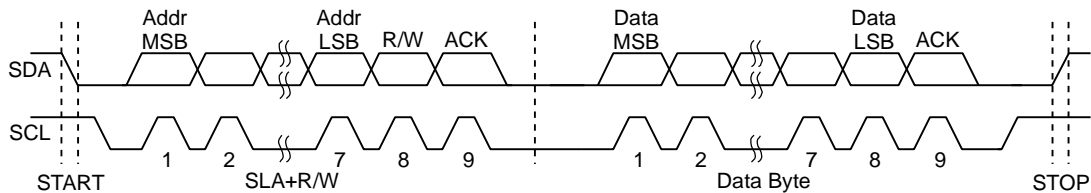

6 Revision History

Revision No.	History
Rev 1209-0-1 – Sept 2012	Preliminary Draft (unreleased)
Rev 1209-1-1 – Sept 2012	Initial Release (unreleased)
Rev 1210-2-2 – Oct 18, 2012	Correct swapped I ² C clock and data signals in Debug Connector J1 pinout table.
Rev 1211-3-3 – Nov 20, 2012	Add notes to Figure 5 regarding sensor orientation and pin 1 location. Add notes to Figure 1 identifying connectors and pin 1 locations.
Rev 1305-4-4 – May 30, 2013	Update references to ILI9320 to include ILI9341 LCD driver IC

7 Notes



email: sales@pdaatl.com

Precision Design Associates, Inc.

736 Johnson Ferry Rd, Suite C-270
Marietta, GA 30068
USA

tel: (770)-971-4490



url: <http://www.pdaatl.com>

© 2012 Precision Design Associates. All rights reserved. Atmel®, Atmel logo and combinations thereof, maXTouch®, QTouch®, and others are registered trademarks of Atmel Corporation or its subsidiaries. Other terms and product names may be registered trademarks or trademarks of others.

X-ON Electronics

Largest Supplier of Electrical and Electronic Components

Click to view similar products for [precision design associates](#) manufacturer:

Other Similar products are found below :

[90-00001-A0](#) [90-00035-A0](#) [TM7000B](#)