

DESCRIPTION

PT2258 is a 6-Channel Electronic Volume Controller IC utilizing CMOS Technology specially designed for the new generation of AV Multi-Channel Audio System. PT2258 provides an I2C Control Interface, an attenuation range of 0 to -79dB at 1dB/step, low noise, and high channel separation. Housed in 20 pins, DIP or SOP, PT2258's pin assignments and application circuit are optimized for easy PCB Layout and cost saving advantages.

APPLICATIONS

- AV Surround Audio Equipment
- Car Audio
- Mini Compo
- Computer Multi-Media Speaker
- Other Audio Equipments

FEATURES

- CMOS Technology
- Low Power Consumption
- Least External Components
- Attenuation Range: 0 to -79dB at 1dB/step
- Operating Voltage: 5 to 9 V
- Low Noise, S/N Ratio>100dB (A-weighting)
- High Channel Separation
- I2C Bus Control Interface
- Selectable Address
- 6-Channel Outputs
- Available in 20 pins, DIP or SOP

BLOCK DIAGRAM

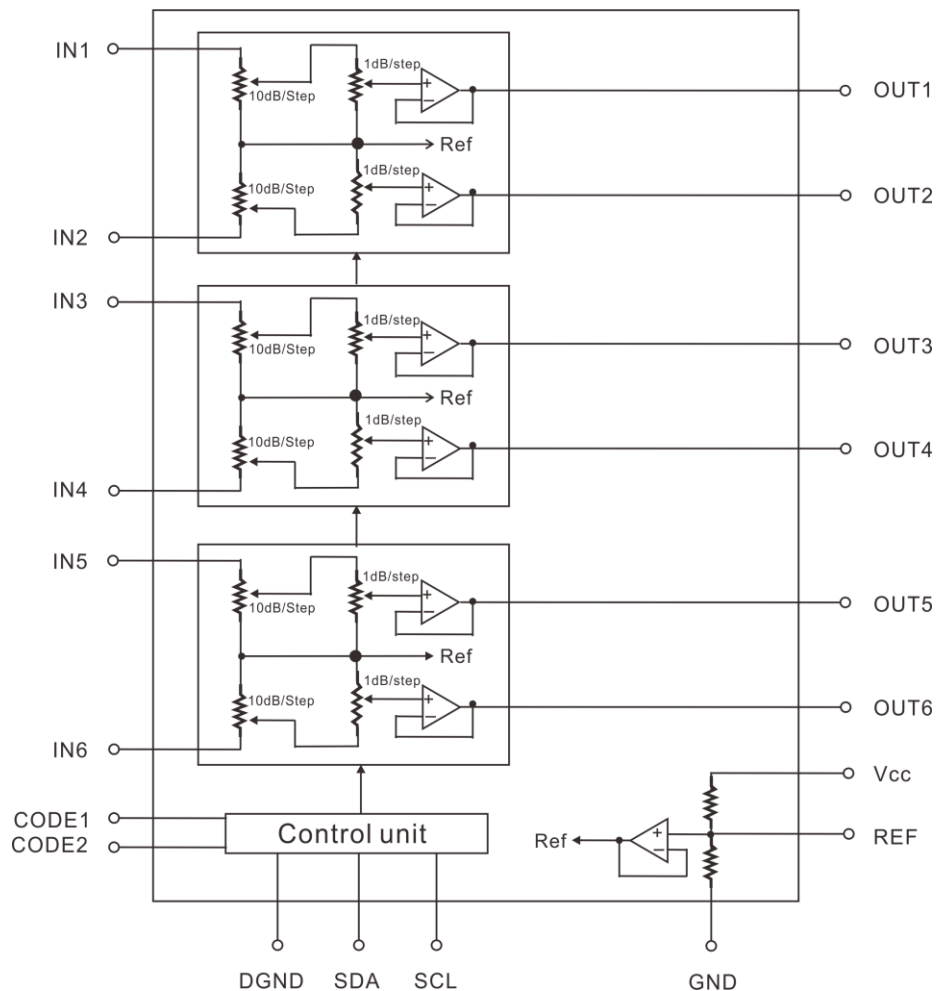

APPLICATION CIRCUIT

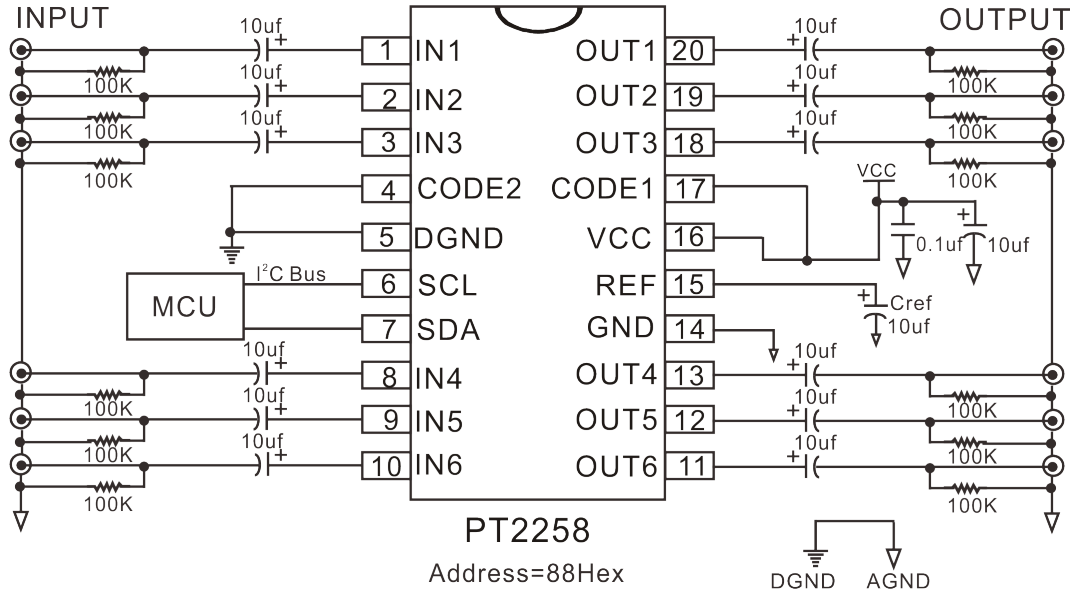

ORDER INFORMATION

Valid Part Number	Package Type	Top Code
PT2258	20 Pins, DIP, 300mil	PT2258
PT2258-S	20 Pins, SOP, 300mil	PT2258-S

PIN CONFIGURATION

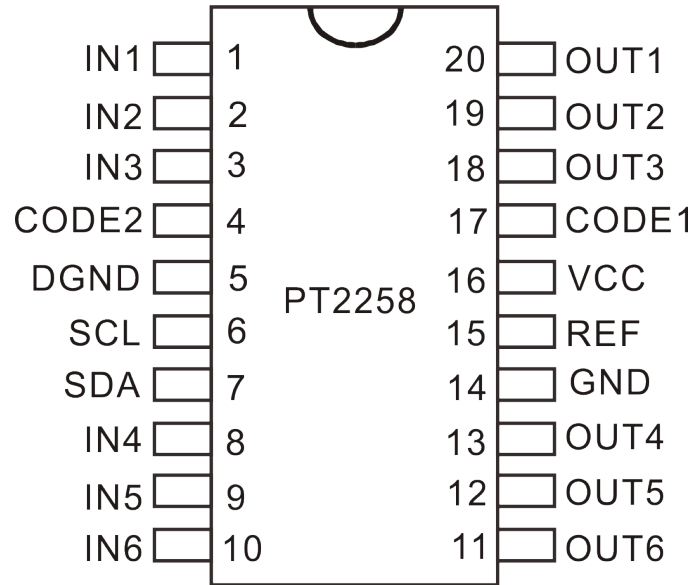

PIN DESCRIPTION

Pin Name	I/O	Description	Pin No.
IN1	I	Channel Input No. 1. Connect a Capacitor to Audio Source	1
IN2	I	Channel Input No. 2 Connect a Capacitor to Audio Source	2
IN3	I	Channel Input No. 3 Connect a Capacitor to Audio Source	3
CODE2	-	Refer to Address Code Section	4
DGND	-	Digital Ground	5
SCL	I	I ² C Clock Input	6
SDA	I	I ² C Data Input	7
IN4	I	Channel Input No. 4 Connect a Capacitor to Audio Source	8
IN5	I	Channel Input No. 5 Connect a Capacitor to Audio Source	9
IN6	I	Channel Input No. 6 Connect a Capacitor to Audio Source	10
OUT6	O	Channel Output No. 6 Connect a Capacitor to the Next Stage	11
OUT5	O	Channel Output No. 5 Connect a Capacitor to the Next Stage	12
OUT4	O	Channel Output No. 4 Connect a Capacitor to the Next Stage	13
GND	-	Ground 14	14
REF	-	Reference Voltage= 1/2 Vcc Connect a Capacitor to the Ground	15
VCC	-	Power Supply Input 16	16
CODE1	-	Refer to the Address Code Section	17
OUT3	O	Channel Output No. 3 Connect a Capacitor to the Next Stage	18
OUT2	O	Channel Output No. 2 Connect a Capacitor to the Next Stage	19
OUT1	O	Channel Output No. 1 Connect a Capacitor to the Next Stage	20

IMPORTANT NOTICE

Princeton Technology Corporation (PTC) reserves the right to make corrections, modifications, enhancements, improvements, and other changes to its products and to discontinue any product without notice at any time.

PTC cannot assume responsibility for use of any circuitry other than circuitry entirely embodied in a PTC product. No circuit patent licenses are implied.

Princeton Technology Corp.
2F, 233-1, Baociao Road,
Sindian Dist., New Taipei City 23145, Taiwan
Tel: 886-2-66296288
Fax: 886-2-29174598
<http://www.princeton.com.tw>

X-ON Electronics

Largest Supplier of Electrical and Electronic Components

Click to view similar products for [Audio DSPs](#) category:

Click to view products by [Princeton](#) manufacturer:

Other Similar products are found below :

[AT85C51SND3B1-RTTUL](#) [BR281W31A101V1G](#) [SA3229-E1-T](#) [IA8201-RDI-01](#) [R3710-CEAA-E1](#) [CS48L10-CNZ](#) [CS48L10-CNZR](#)
[CS47024C-CQZ](#) [CS48L10-CWZR](#) [CS48L11-CNZ](#) [TAS3204PAGR](#) [BD37514FS-E2](#) [NJM2294V-TE1](#) [LC823450TA-2H](#) [LC823450XDTBG](#)
[ZL38052LDG1](#) [ADAU1450WBCPZ-RL](#) [ADAU1701JSTZ-RL](#) [ADAU1701JSTZ](#) [FSEIASLD-32G](#) [CI1103](#) [CS47048C-CQZ](#) [CS48560-DQZ](#)
[CS496102-CQZ](#) [CS181002-CQZ](#) [PT2399](#) [XD567](#) [XD1881](#) [TDA7440D013TR](#) [IA8201CQ](#) [SPK2611HM7H-1-2](#) [ALC662-VD0-GR](#)
[ALC662-GR](#) [CM108B](#) [CM118B](#) [HS-100B](#) [S1V30120F01A100](#) [CMX138AE1](#) [LC786820E-6E03-3H](#) [CMX823E4](#) [LC823455XATBG](#)
[LC89058W-E](#) [CM119BN](#) [CM6533N](#) [CM6530N](#) [THCV235-NNTA](#) [THCV236-NNTA](#) [XFS3031CNP](#) [BD37033FV-ME2](#) [BM28720MUV-E2](#)