



## DESCRIPTION

PT2272 is a remote control decoder paired with PT2262 utilizing CMOS Technology. It has 12-bit of tri-state address pins providing a maximum of 531,441 (or 312) address codes; thereby, drastically reducing any code collision and unauthorized code scanning possibilities. PT2272 is available in several options to suit every application need: variable number of data output pins, latch or momentary output type.

## FEATURES

- CMOS Technology
- Low Power Consumption
- Very High Noise Immunity
- Up to 12 Tri-State Code Address Pins
- Up to 6 Data Pins
- Wide Range of Operating Voltage: VCC=4~15V
- Single Resistor Oscillator
- Latch or Momentary Output Type
- Available in DIP and SOP

## APPLICATIONS

- Car Security System
- Garage Door Controller
- Remote Control Fan
- Home Security/Automation System
- Remote Control Toys
- Remote Control for Industrial Use



## BLOCK DIAGRAM

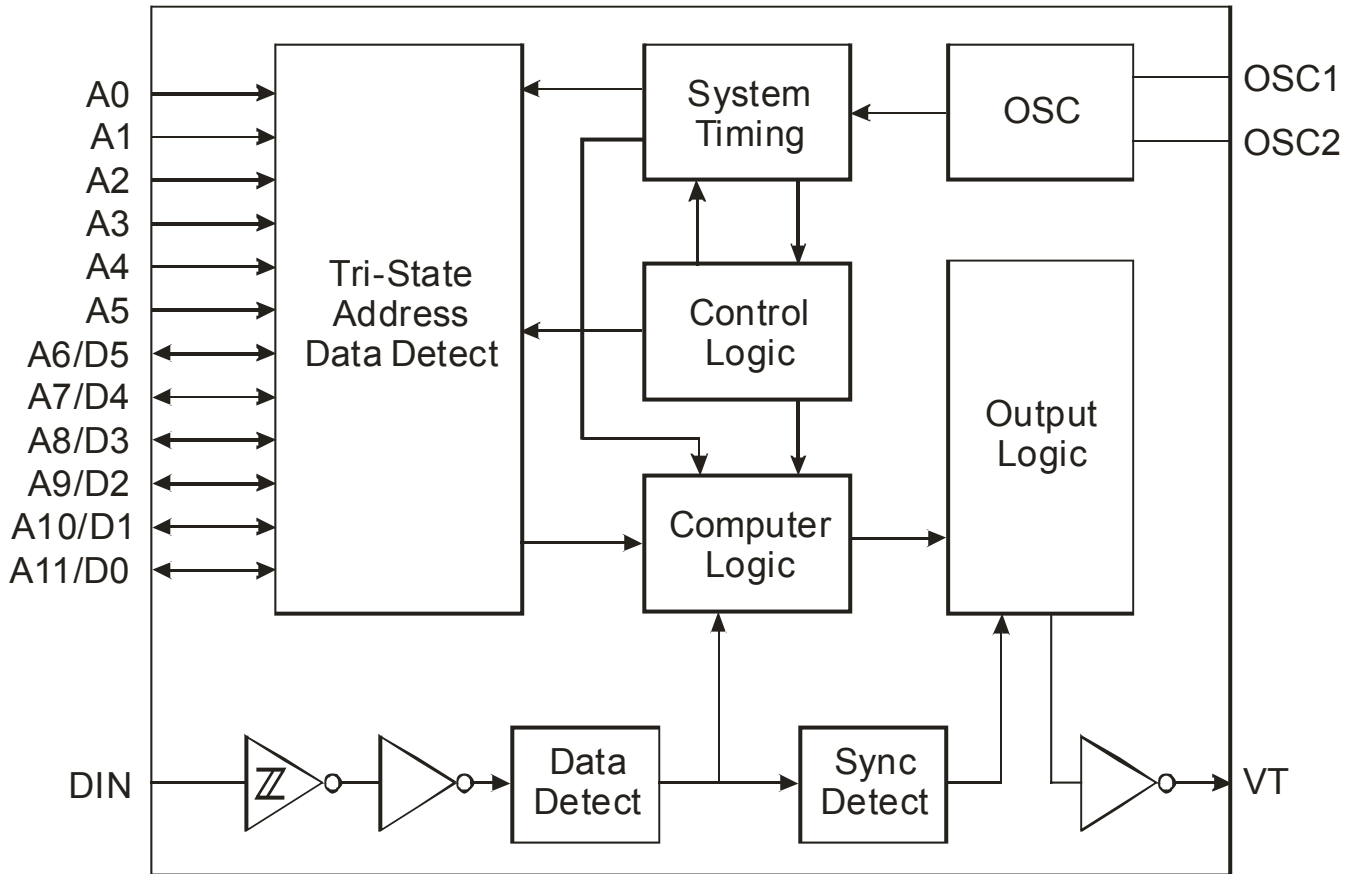



# PIN CONFIGURATION

## 18 PINS

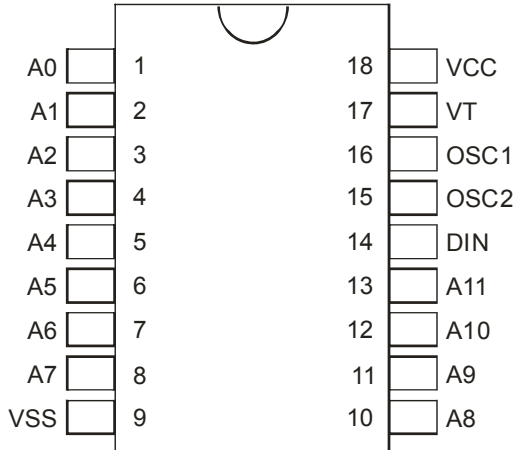

PT2272

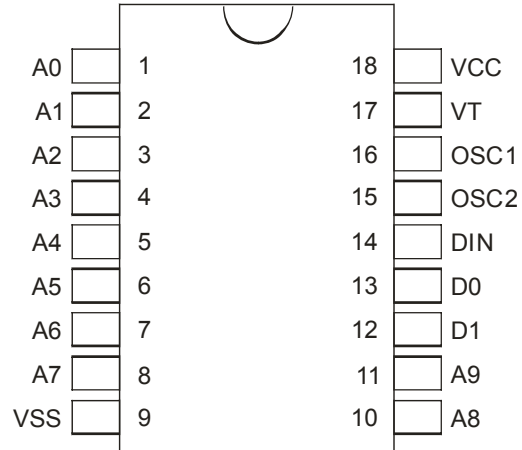

PT2272A-M2/L2

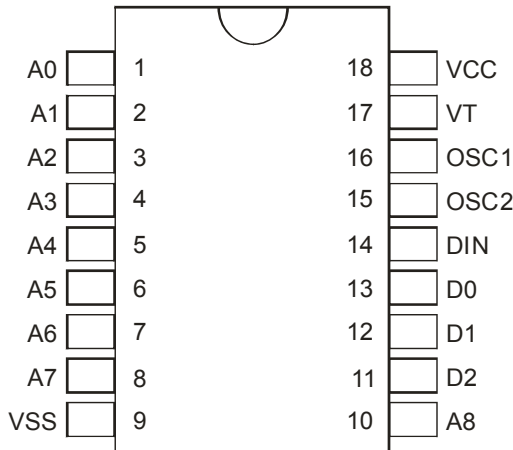

PT2272-M3/L3

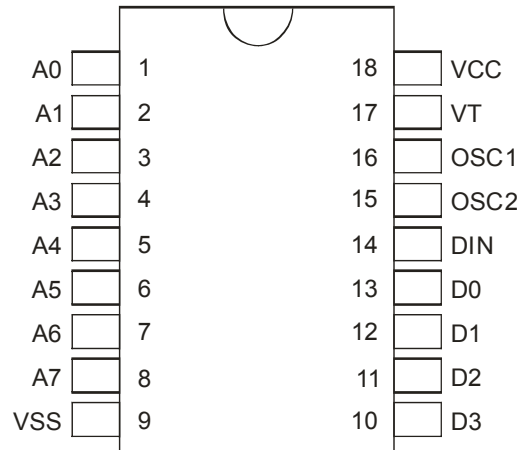

PT2272-M4/L4

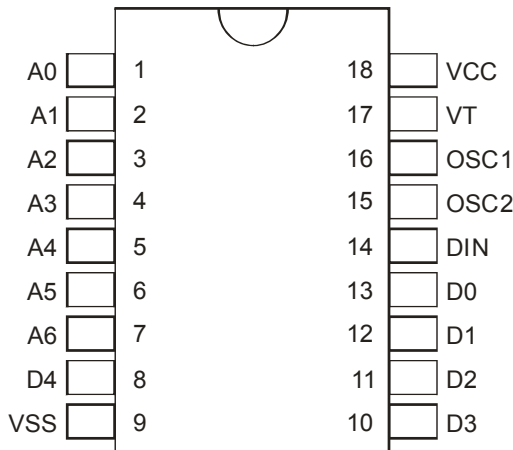

PT2272-M5/L5

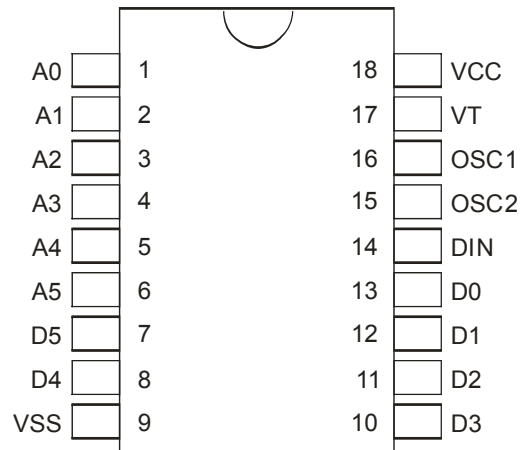

PT2272-M6/L6



Remote Control Decoder

PT2272

20 PINS

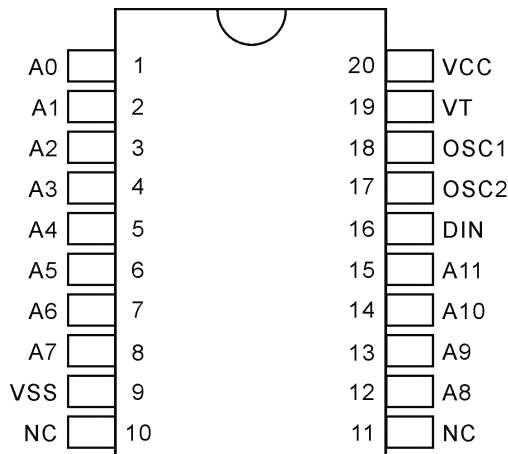

PT2272-S

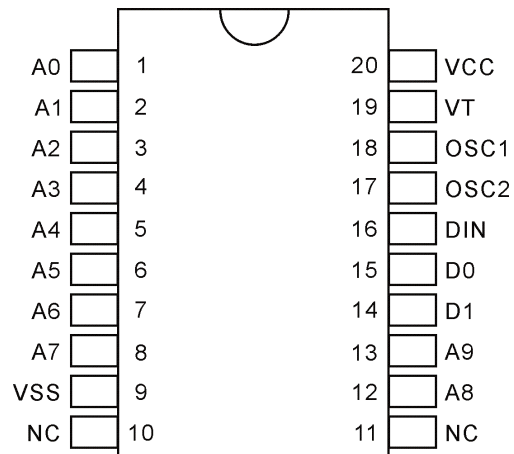

PT2272A-M2S/L2S

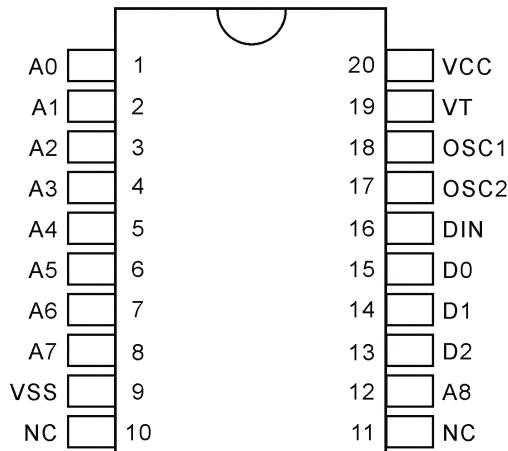

PT2272-M3S/L3S

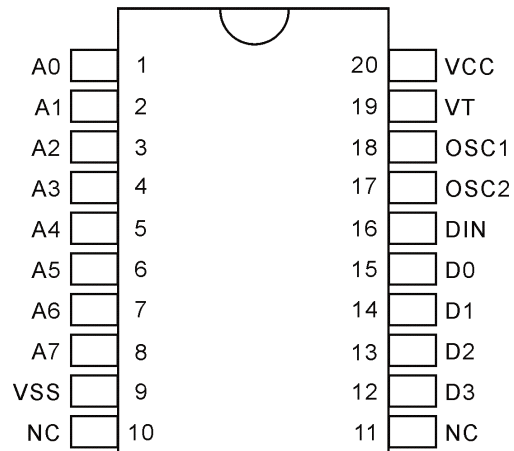

PT2272-M4S/L4S

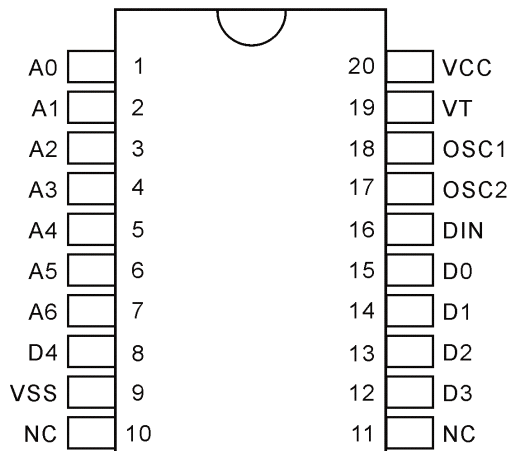

PT2272-M5S/L5S

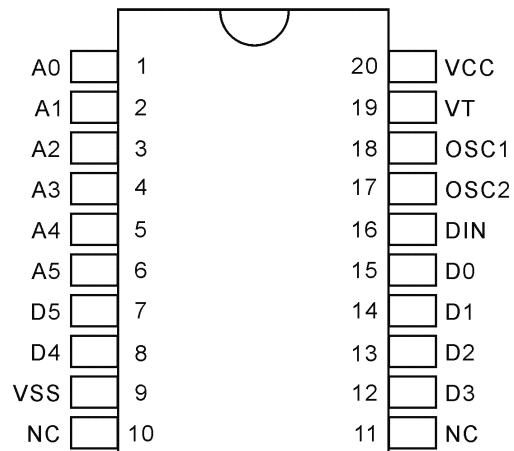

PT2272-M6S/L6S



## PIN DESCRIPTION

Pin Name	I/O	Description	Pin No.	
			18pins	20pins
A0 ~ A5	I	Code Address Pin Nos. 0 ~ 5. These six tri-state pins are detected by PT2272 to determine the encoded waveform bit 0 ~ bit 5. Each pin can be set to "0", "1", or "f" (floating).	1 ~ 6	1 ~ 6
A6/D5 ~ A11/D0	I/O	Code Address Pin Nos. 6 ~ 11/Data Pin Nos. 5 ~ 0. These six pins are used as higher address input bits or data output pins depending on the version (type) of PT2272 used. When used as address inputs, these pins are tri-state input pins and each pin can be set to "0", "1", or "f" (floating). When used as output pins, these pins are driven to VCC if (1) the address decoded from the waveform that was received matches the address setting at the address input pins, and (2) the corresponding data bits received is a "1" bit. Otherwise, they are driven to VSS.	7 ~ 8 10 ~ 13	7 ~ 8 12 ~ 15
DIN	I	Data Input Pin. The encoded waveform received is serially fed to PT2272 at this pin.	14	16
OSC 1	I	Oscillator Pin No.1	15	17
OSC 2	O	Oscillator Pin No. 2		
VT	O	Valid Transmission. Active High Signal. VT in high state signifies that PT2272 receives valid transmission waveform.	17	19
VCC	-	Positive Power Supply	18	20
VSS	-	Negative Power Supply	9	9
NC	-	No Connection	-	10 ~ 11



## FUNCTION DESCRIPTION

PT2272 decodes the waveform received and fed into the DIN pin. The Waveform is decoded into code word that contains the address, data and sync bits. The decoded address bits are compared with the address set at the address input pins. If both addresses match for 2 consecutive code words, PT2272 drives - (1) the data output pin(s) whose corresponding data bit(s) is then decoded to be a "1" bit, and (2) the VT output -- to high voltage (high state).

## RF OPERATION

### CODE BITS

A Code Bit is the basic component of the encoded waveform, and can be classified as either an AD (Address/Data) Bit or a SYNC (Synchronous) Bit.

### Address/Data (AD) Bit Waveform

An AD Bit can be designated as Bit "0", "1" or "f", if it is in low, high or floating state respectively. One bit waveform consists of 2 pulse cycles. Each pulse cycle has 16 oscillating time periods. For further details, please refer to the diagram below:

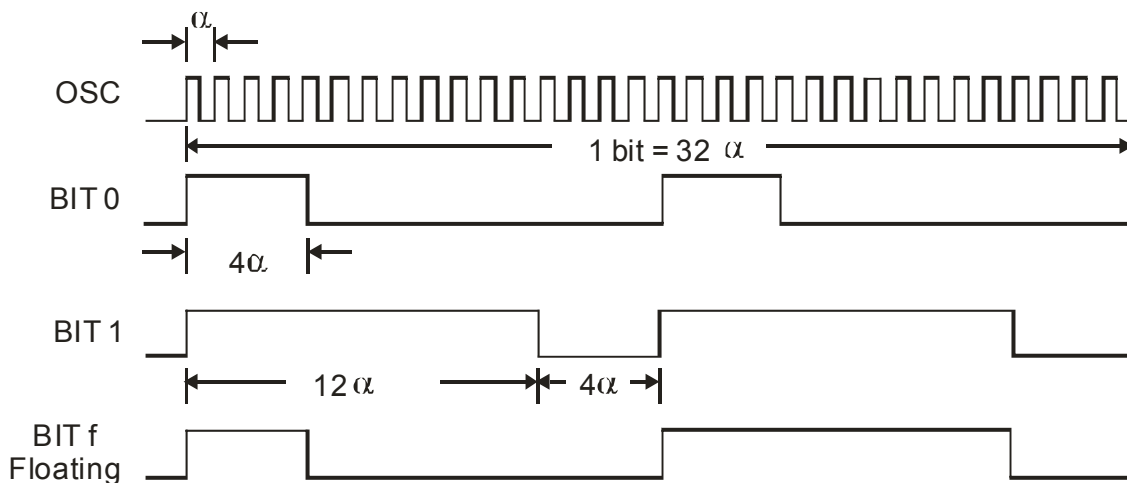

where:  $\alpha$  = Oscillating Clock Period  
Bit 1 is only available for Address Bit



Remote Control Decoder

PT2272

**Synchronous (Sync.) Bit Waveform**

The Synchronous Bit Waveform is 4 bits long with 1/8 bit width pulse. Please refer to the diagram below:

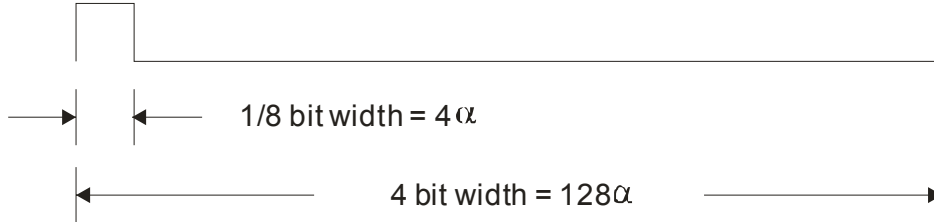

Note: 1 bit = 32 α

**CODE WORD**

A group of Code Bits is called a Code Word. A Code Word consists of 12 AD bits followed by one Sync Bit. The 12 AD bits are interpreted as either address or data bits depending on the PT2272 version used. Please refer to the diagrams below:

**PT2272:**

A0	A1	A2	A3	A4	A5	A6	A7	A8	A9	A10	A11	SYNC
----	----	----	----	----	----	----	----	----	----	-----	-----	------

**PT2272A-M2/L2:**

A0	A1	A2	A3	A4	A5	A6	A7	A8	A9	D1	D0	SYNC
----	----	----	----	----	----	----	----	----	----	----	----	------

**PT2272-M3/L3:**

A0	A1	A2	A3	A4	A5	A6	A7	A8	D2	D1	D0	SYNC
----	----	----	----	----	----	----	----	----	----	----	----	------

**PT2272-M4/L4:**

A0	A1	A2	A3	A4	A5	A6	A7	D3	D2	D1	D0	SYNC
----	----	----	----	----	----	----	----	----	----	----	----	------

**PT2272-M5/L5:**

A0	A1	A2	A3	A4	A5	A6	D4	D3	D2	D1	D0	SYNC
----	----	----	----	----	----	----	----	----	----	----	----	------

**PT2272-M6/L6:**

A0	A1	A2	A3	A4	A5	D5	D4	D3	D2	D1	D0	SYNC
----	----	----	----	----	----	----	----	----	----	----	----	------





### SINGLE RESISTOR OSCILLATOR

The built-in oscillator circuitry of PT2272 allows a precision oscillator to be constructed with only an external resistor. For the PT2272 to decode correctly the waveform that was received, the oscillator frequency of PT2272 must be 2.5~8 times that of the transmitting PT2262. It is a good practice to center the PT2272 oscillator frequency in this window to gain best window margin at both sides. The typical oscillator with various resistor values is shown below for both PT2262 and PT2272.

Encoder OSC Frequency

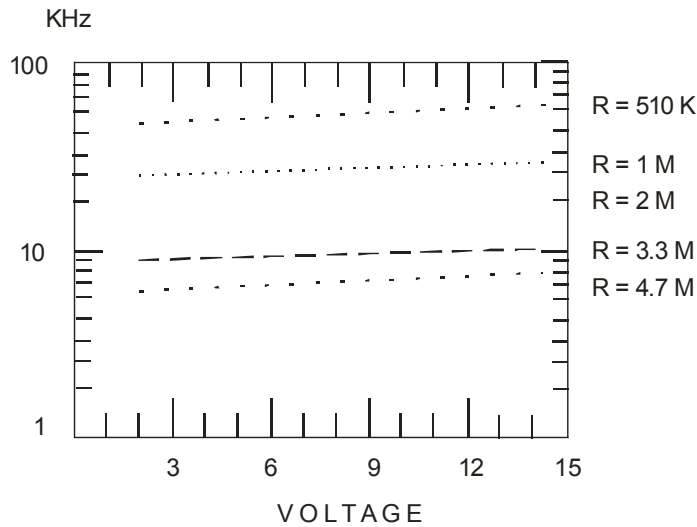

Decoder OSC Frequency

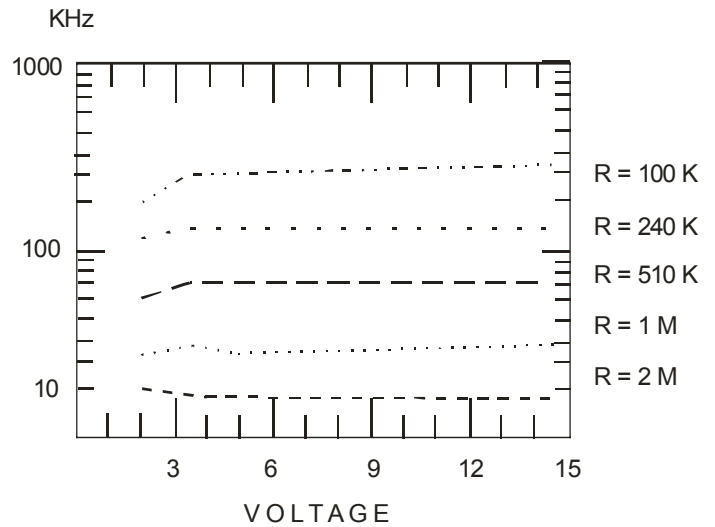

Suggested oscillator resistor values are shown below.

PT2262	PT2272
4.7MΩ	820KΩ *
3.3MΩ	680KΩ *
1.2MΩ	200KΩ **

Note:

\* -- Operates when PT2272's VCC=5V to 15V

\*\* -- Operates when PT2272's VCC= 4V to 15V

This means that if the PT2272 supply voltage is lower than 5V, you have to use a lower oscillator resistor value for both PT2262 and PT2272.





## IR OPERATION

In the IR Type of Operation, the functions are similar to the above descriptions, except that the output waveform carried by PT2262-IR has a frequency of 38KHz. Details are as follows.

## CODE BITS

The Code Bits are further modulated with a 38KHz carrier frequency and can be "0", "1" or "f" bit. Their waveforms are shown in the diagram below.

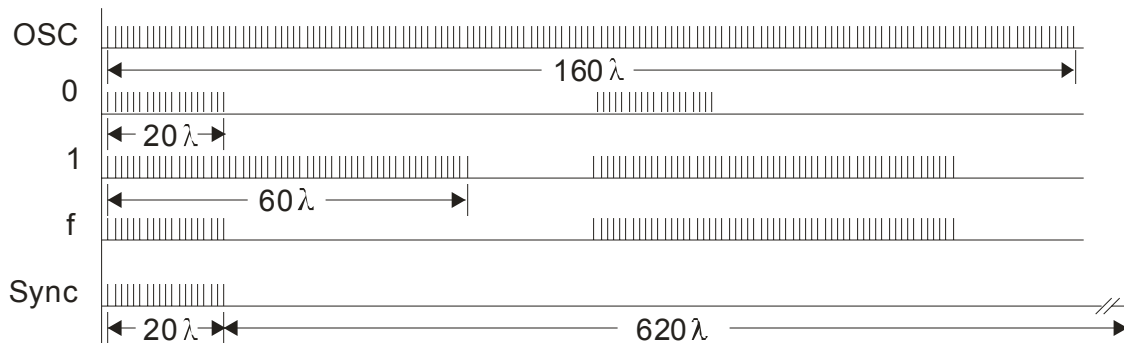

Note:  $\lambda = 2$  clock lengths

## CODE WORD

A Code Word is made up of code bits and the format is the same as that of the RF Code Frame.

## CODE FRAME

Likewise, a Code Frame is made up of Code Words and the format is the same as that of RF Type of Operation.

## OSCILLATOR

PT2262-IR is specially designed for infrared remote control applications and its output waveform carries 38KHz frequency. To get the 38KHz carrier frequency at the data output, the oscillator frequency must be 76KHz. A 440K $\Omega$  resistor connected between OSC1 and OSC2 pins of PT2262-IR is recommended. Moreover, for a matching decoder frequency, 1M $\Omega$  resistor connected between the OSC1 and OSC2 pins of PT2272 is also recommended.



### VALID TRANSMISSION

When PT2272 receives a transmission code word, it initially checks whether this is a valid transmission. For a transmission to be valid, (1) it must be a Complete Code Word, and (2) the Address Bits must match the Address Setting at the Address Pins. After two consecutive valid transmissions, PT2272 (1) drives the data pins according to the data bits received, and (2) raises VT to high voltage (high state).

The timings are shown in the following diagram.

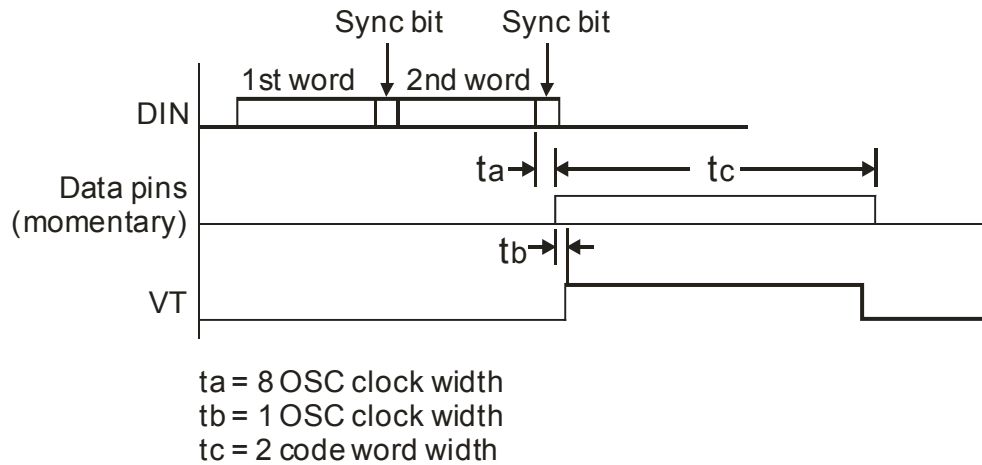

### LATCH OR MOMENTARY DATA OUTPUT TYPE

PT2272 uses either the latch or the momentary data output type depending on the PT2272 version used. The latch type (PT2272-Lx) activates the data out during transmission and this data is sustained in the memory until another data is inputted or entered. A momentary type (PT2272-Mx), on the other hand, activates the data out only during transmission. In the momentary type, the data does not remain in the memory after the transmission is completed. Please refer to the diagram below:

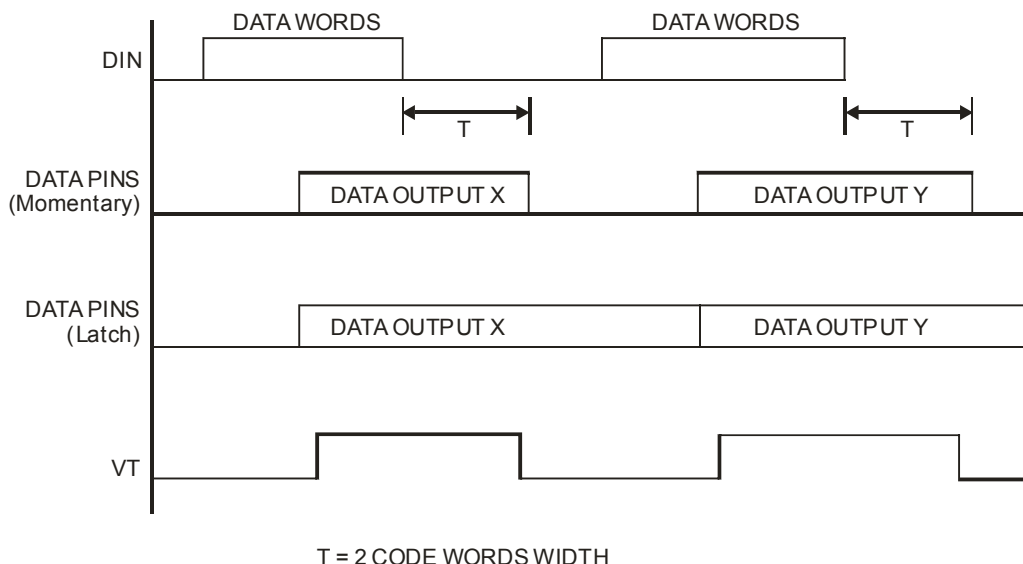



## OPERATION FLOWCHART

### DECODER WITHOUT DATA OUTPUT PIN

1. When Power is turned on, PT2272 activates the Stand-By Mode.
2. It then searches for signals. If there is no signal received, it remains in the Stand-By Mode; otherwise, the address bits received are compared with the address configuration of the pins.
3. The VT goes high signifying the validation of transmission only when there are two (2) continuous frames that contain matched address bits; otherwise, VT will not be activated and the Stand-By Mode remains active.
4. Then, the Address Bits are again checked. Two continuous mismatches of the address bits would disable the VT and make the Stand-By Mode active; otherwise, the address bits are continuously checked.

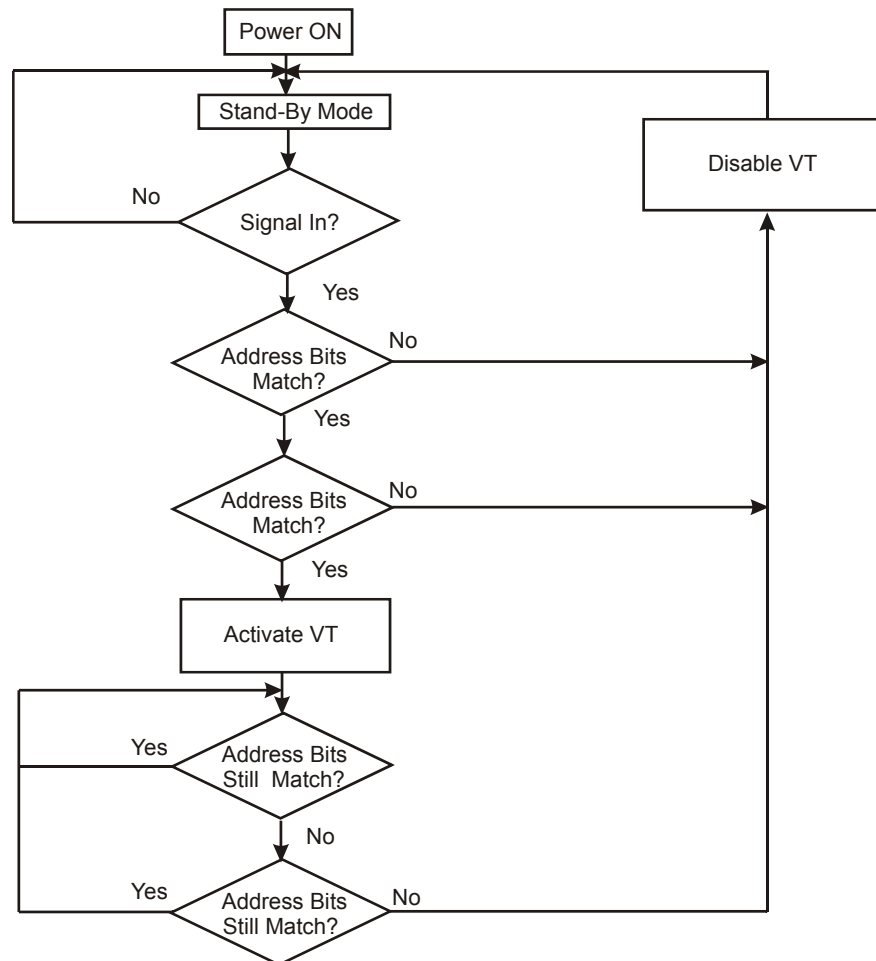



## DECODER WITH DATA OUTPUT PINS

1. When Power is turned ON, PT2272 activates the Stand-By Mode.
2. It then searches for signals. If there is no signal received, it remains in the Stand-By Mode; otherwise, the address bits are compared with the address configuration of the pins.
3. Whenever the Address Bits in a Frame match with that of the Address Configuration of the Pin, the data bits are stored into the memory. Also, when this IC finds two (2) continuous and identical data having the same address bits, the data output(s) is activated and the VT is enabled. The VT is disabled when there are 2 continuous mismatched addresses. For the momentary type, the data output is reset; while for the latch type, the data output is sustained.

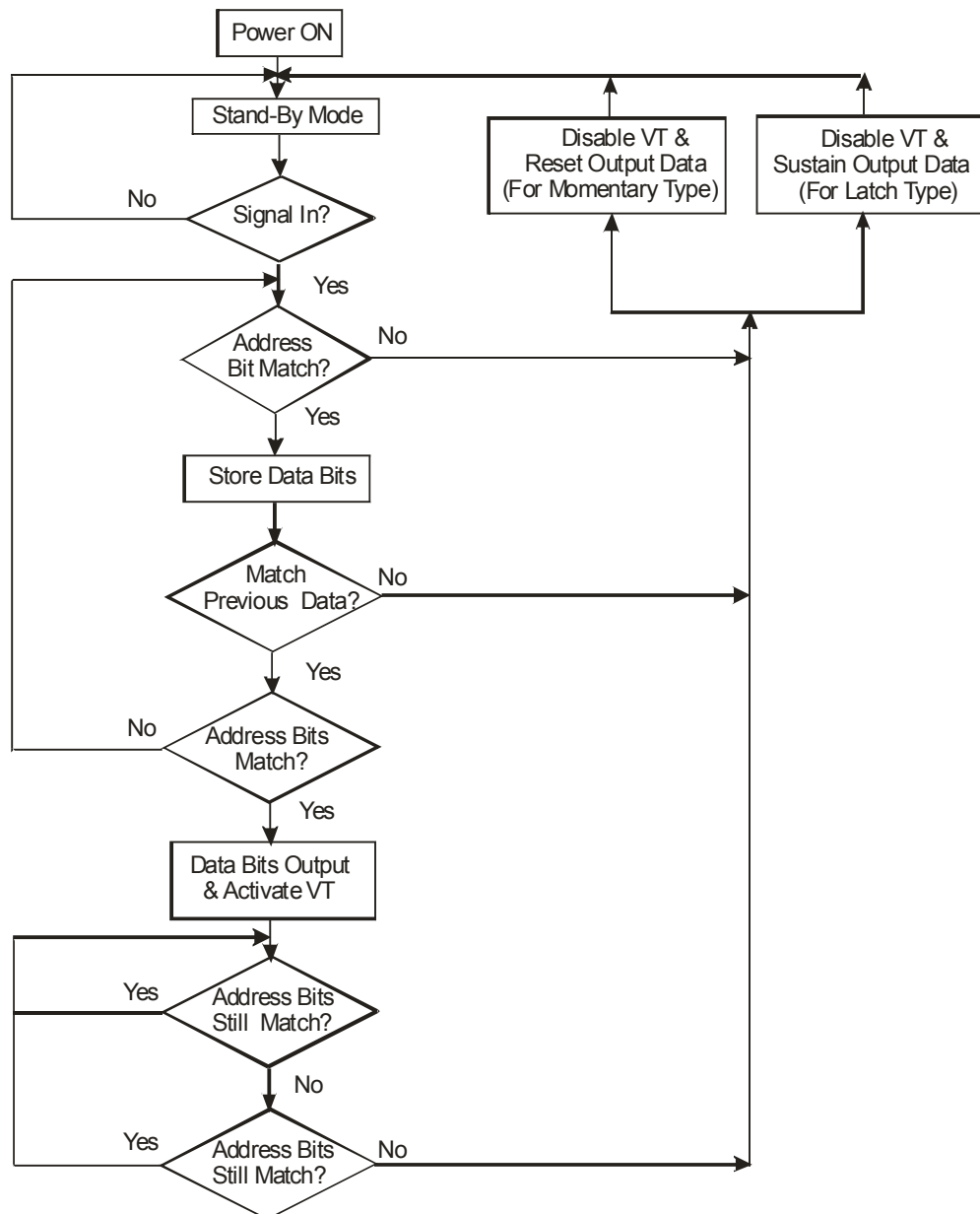



## ABSOLUTE MAXIMUM RATINGS

Parameter	Symbol	Rating	Unit
Supply Voltage	VCC	-0.3 ~ 16.0	V
Input Voltage	VI	-0.3 ~ VCC+0.3	V
Output Voltage	VO	-0.3 ~ VCC+0.3	V
Operating Temperature	Topr	-40 ~ +85	°C
Storage Temperature	Tstg	-65 ~ 150	°C

## DC ELECTRICAL CHARACTERISTICS

Parameter	Symbol	Conditions	Min.	Typ.	Max.	Unit
Supply Voltage	VCC	-	4	-	15	V
Stand-by Current	ISB	VCC = 12V DIN = 0V OSC1 = 0V	-	0.1	1	μA
DOUT Output Driving Current	IOH	VCC = 5V VOH = 3V	-3	-	-	mA
		VCC = 8V VOH = 4V	-6	-	-	mA
		VCC = 12V VOH = 6V	-10	-	-	mA
DOUT Output Sinking Current	IOL	VCC = 5V VOH = 3V	2	-	-	mA
		VCC = 8V VOH = 4V	5	-	-	mA
		VCC = 12V VOH = 6V	9	-	-	mA
"H" Input Voltage	VIH	VCC	0.7VCC	-	VCC	V
"L" Input Voltage	VIL	VCC	0	-	0.3VCC	V



## APPLICATION CIRCUIT

### PT2272 (NO DATA) RF APPLICATION

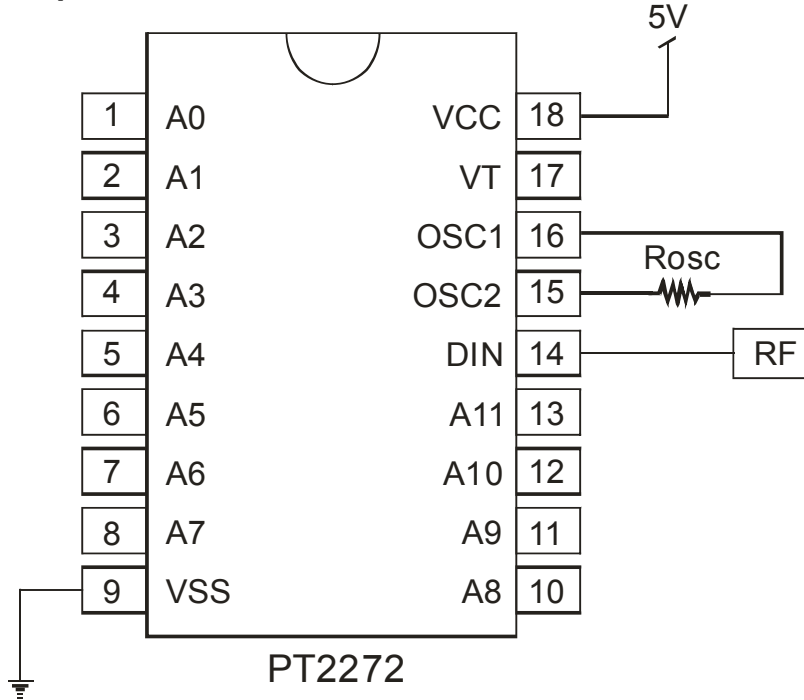

### PT2272 (4 DATA) RF APPLICATION CIRCUIT

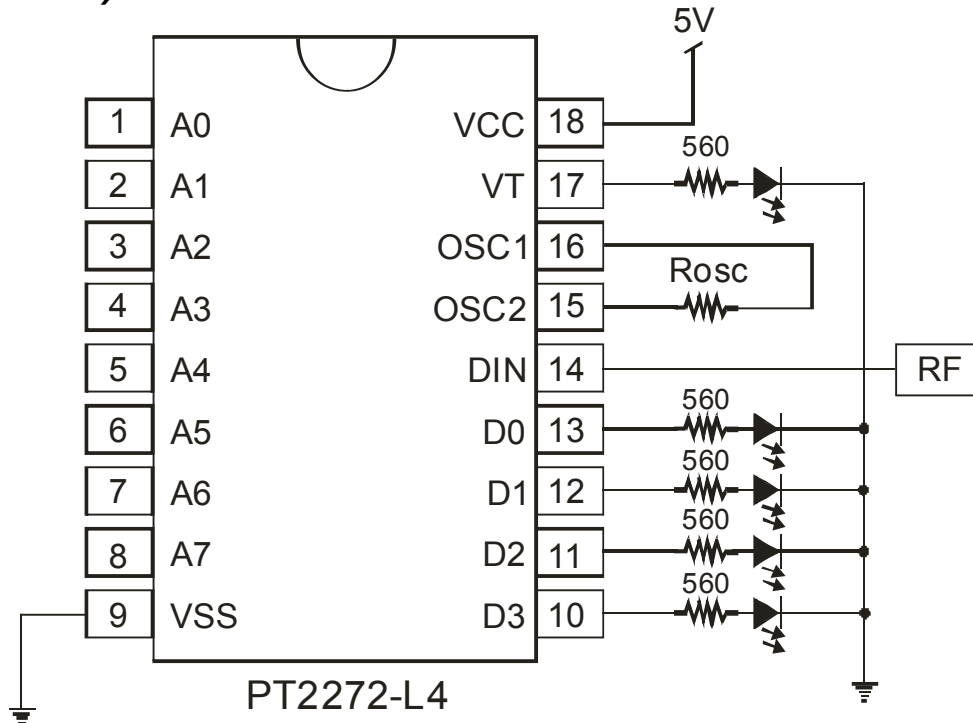



**PT2272 (4 DATA) IR APPLICATION CIRCUIT**

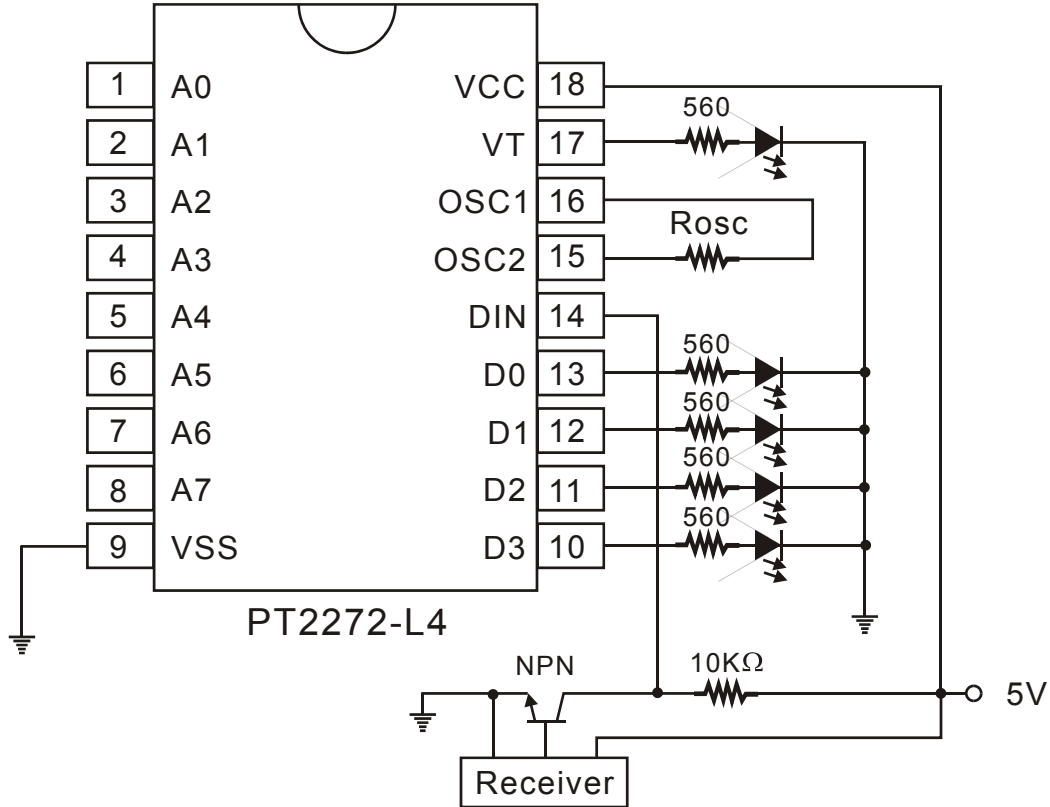



## ORDER INFORMATION

Valid Part No.	Package Type	Data Bits	Output Type	Top Code
PT2272A-M2-S18	18 PINS, SOP	2	Momentary	PT2272

Valid Part No.	Package Type	Data Bits	Output Type	Top Code
PT2272	18 PINS, DIP	-	*	PT2272
PT2272-L2	18 PINS, DIP	2	Latch	PT2272-L2
PT2272-L3	18 PINS, DIP	3	Latch	PT2272-L3
PT2272-L4	18 PINS, DIP	4	Latch	PT2272-L4
PT2272-L5	18 PINS, DIP	5	Latch	PT2272-L5
PT2272-L6	18 PINS, DIP	6	Latch	PT2272-L6
PT2272-M2	18 PINS, DIP	2	Momentary	PT2272-M2
PT2272-M3	18 PINS, DIP	3	Momentary	PT2272-M3
PT2272-M4	18 PINS, DIP	4	Momentary	PT2272-M4
PT2272-M5	18 PINS, DIP	5	Momentary	PT2272-M5
PT2272-M6	18 PINS, DIP	6	Momentary	PT2272-M6
PT2272A-L2	18 PINS, DIP	2	Latch	PT2272A-L2
PT2272A-M2	18 PINS, DIP	2	Momentary	PT2272A-M2

Valid Part No.	Package Type	Data Bits	Output Type	Top Code
PT2272-S	20 PINS, SOP	-	*	PT2272-S
PT2272-L3S	20 PINS, SOP	3	Latch	PT2272-L3S
PT2272-L4S	20 PINS, SOP	4	Latch	PT2272-L4S
PT2272-L5S	20 PINS, SOP	5	Latch	PT2272-L5S
PT2272-L6S	20 PINS, SOP	6	Latch	PT2272-L6S
PT2272-M2S	20 PINS, SOP	2	Momentary	PT2272-M2S
PT2272-M3S	20 PINS, SOP	3	Momentary	PT2272-M3S
PT2272-M4S	20 PINS, SOP	4	Momentary	PT2272-M4S
PT2272-M5S	20 PINS, SOP	5	Momentary	PT2272-M5S
PT2272-M6S	20 PINS, SOP	6	Momentary	PT2272-M6S
PT2272A-L2S	20 PINS, SOP	2	Latch	PT2272A-L2S
PT2272A-M2S	20 PINS, SOP	2	Momentary	PT2272A-M2S

Note: \*=use VT (Valid Transmission).





## PACKAGE INFORMATION

18 PINS, SOP, 300MIL

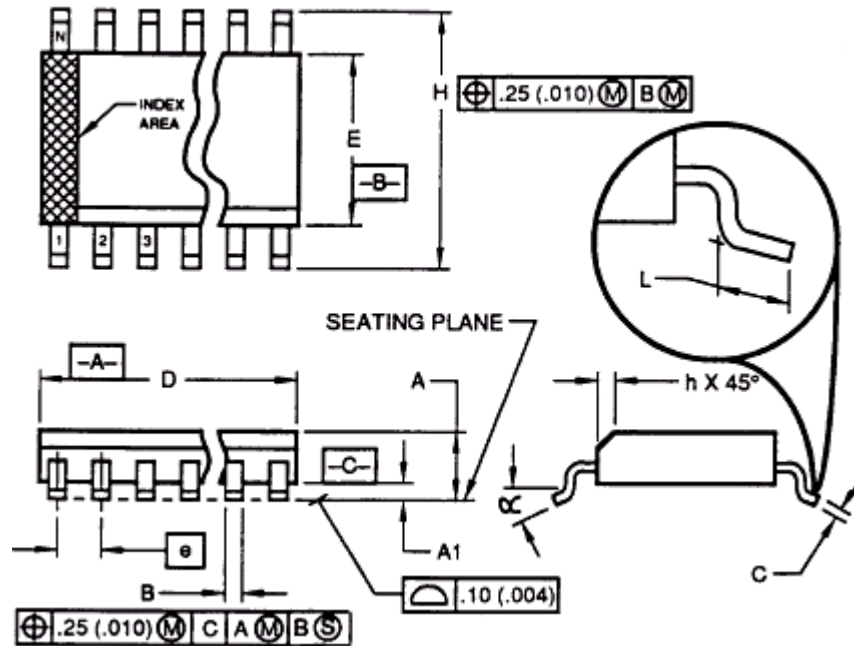

Symbol	Min.	Nom.	Max.
A	2.35		2.65
A1	0.10		0.30
B	0.33		0.51
C	0.23		0.32
D	11.35		11.75
E	7.40		7.60
e	1.27 BASIC		
H	10.00		10.65
h	0.25		0.75
L	0.40		1.27
$\infty$	0°		8°



Notes:

1. Dimensioning and tolerancing per ANSI Y14.5-1982.
2. Dimension "D" does not include mold flash, protrusions or gate burrs. Mold Flash, protrusion or gate burrs shall not exceed 0.15mm (0.006 in) per side.
3. Dimension "E" does not include interlead flash or protrusions. Interlead flash or protrusions shall not exceed 0.25mm (0.010 in) per side.
4. The chamfer on the body is optional. If it is not present, a visual index feature must be located within the crosshatched area.
5. "L" is the length of the terminal for soldering to substrate.
6. "N" is the number of terminal positions. (N=18)
7. The lead width "B" as measured 0.36mm (0.014 in) or greater above the seating plane, shall not exceed a maximum value of 0.61mm (0.24 in)
8. Controlling dimension: MILLIMETER.
9. Refer to JEDEC MS-013 Variation AB.

JEDEC is the trademark of JEDEC SOLID STATE TECHNOLOGY ASSOCIATION.



Remote Control Decoder

PT2272

18 PINS, DIP, 300MIL

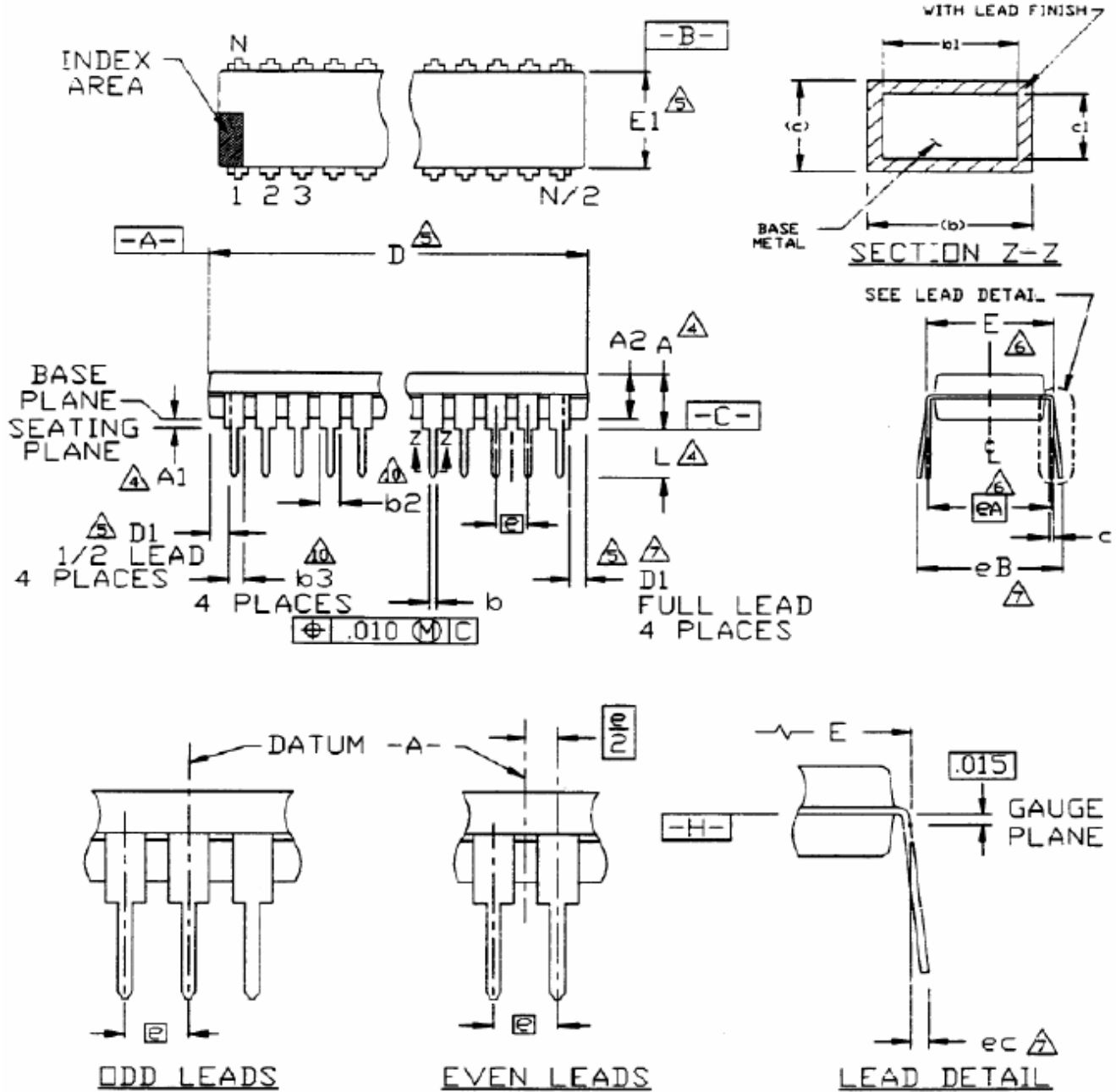



Symbol	Min.	Nom.	Max.
A			0.21
A1	0.15		
A2	0.115	0.13	0.195
b	0.014	0.018	0.022
b2	0.045	0.06	0.07
b3	0.03	0.039	0.045
c	0.008	0.01	0.014
D	0.88	0.90	0.92
D1	0.005		
E	0.30	0.31	0.325
E1	0.24	0.25	0.28
e	0.1 BASIC		
eA	0.3 BASIC		
eB			0.43
eC	0.00		0.60
L	0.115	0.13	0.15

Notes:

- All dimensioning are in INCHES.
  - Dimensioning and tolerancing per ANSI Y14.5M-1982.
  - Dimension "A", "A1" and "L" are measured with package seated in JEDEC Seating Plane Gauge GS-3.
  - "D", "D1" and "E1" dimensions do not include mold flash or protrusions. Mold flash or protrusions shall not exceed 0.010 inch.
  - "E" and "eA" measured with the leads constrained to be perpendicular to datum  $\square$ -C.
  - "eB" and "eC" are measured at the lead tips with the leads unconstrained.
  - "N" is the number of terminal position (N=18).
  - Pointed or rounded lead tips are preferred to ease insertion.
  - "b2" and "b3" maximum dimensions are not include dambar protrusions. Dambar protrusions shall not exceed 0.010 inch (0.25mm)
  - Distance between leads including Dambar protrusions to be 0.005 inch minimum.
  - Datum plane  $\square$ -H coincident with the bottom of lead, where lead exits body.
  - Refer to JEDEC MS-001, Variation AC
- JEDEC is the trademark of JEDEC SOLID STATE TECHNOLOGY ASSOCIATION.



Remote Control Decoder

PT2272

20PINS, SOP, 300 MIL

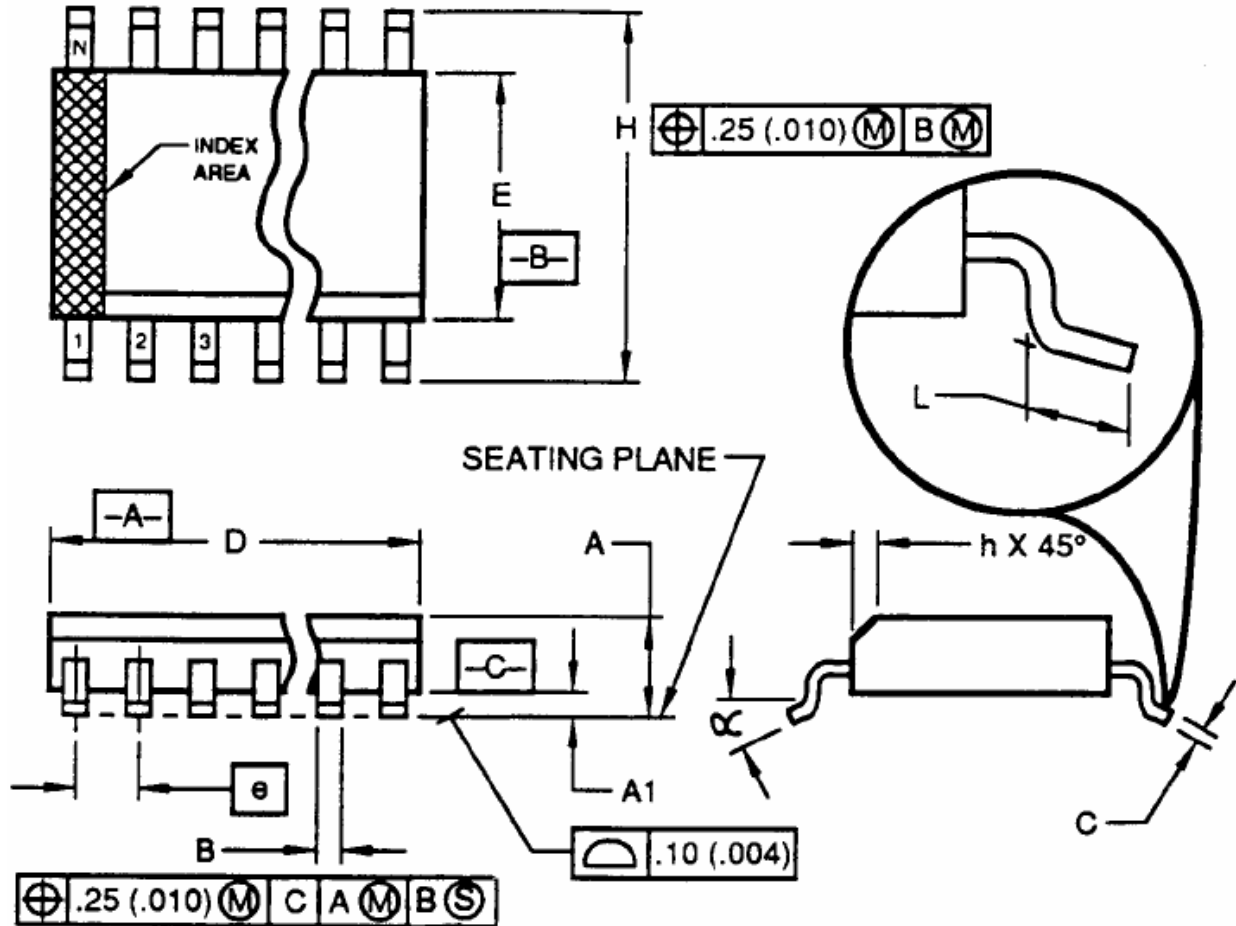

Symbol	Min.	Nom.	Max.
A	2.35		2.65
A1	0.10		0.30
B	0.33		0.51
C	0.23		0.32
D	12.60		13.00
E	7.40		7.60
e	1.27 bsc.		
H	10.00		10.65
h	0.25		0.75
L	0.40		1.27
$\alpha$	0°		8°



## Remote Control Decoder

**PT2272**

### Notes:

1. Dimensioning and tolerancing per ANSI Y14.5M-1982.
2. Dimension "D" does not include mold flash, protrusions or gate burrs. Mold Flash, protrusion or gate burrs shall not exceed 0.15 mm (0.006 in) per side.
3. Dimension "E" does not include interlead flash or protrusions. Interlead flash or protrusions shall not exceed 0.25 mm (0.010 in) per side.
4. The chamfer on the body is optional. If it is not present, a visual index feature must be located within the crosshatched area.
5. "L" is the length of the terminal for soldering to a substrate.
6. N is the number of the terminal positions (N=20)
7. The lead width "B" as measured 0.36 mm (0.014 in) or greater above the seating plane, shall not exceed a maximum value of 0.61 mm (0.24 in).
8. Controlling dimension: MILLIMETER.
9. Refer to JEDEC MS-013, Variation AC.

JEDEC is the trademark of JEDEC SOLID STATE TECHNOLOGY ASSOCIATION.

## X-ON Electronics

Largest Supplier of Electrical and Electronic Components

*Click to view similar products for [Interface - CODECs](#) category:*

*Click to view products by [Princeton](#) manufacturer:*

Other Similar products are found below :

[CS4205-KQZ](#) [WM8944BECS/R](#) [TSCS42A2X1NLGIZAX](#) [DA7219-02VBA](#) [BU92001KN-E2](#) [TLC320AD52CPT](#) [TDA7293V-E](#)  
[WM8998ECS/R](#) [CS42L73-CRZR](#) [STA529Q](#) [TLV320AIC14IDBT](#) [TLV320AIC23BIPWRQ1](#) [TLV320AIC23IPW](#) [TLV320AIC34IZASR](#)  
[TLV320AIC3262IYZFR](#) [SGTL5000XNLA3R2](#) [MAX98089ETN+T](#) [TLV320DAC3203IRGER](#) [DA7212-01UM2](#) [WM8904CGEFL/RV](#)  
[6PAIC3106IRGZRQ1](#) [CS42436-DMZ](#) [TSCS25A3X1NDGXZAX](#) [LE58QL063HVC](#) [ISD17120PY](#) [SSM2167-1RMZ](#) [HT34118ANZ](#)  
[AD1939YSTZRL](#) [AD1835AASZ](#) [AD1939WBSTZ](#) [ADAU1761BCPZ](#) [ADAU1761BCPZ-R7](#) [ADAU1961WBCPZ-R7](#) [AD1938WBSTZ](#)  
[AD1938WBSTZ-RL](#) [CS42448-DQZR](#) [WM8904CGEFL/V](#) [WM8994ECS/R](#) [CS4234-ENZ](#) [CS42416-CQZ](#) [CS42426-CQZ](#) [CS42432-CMZ](#)  
[CS42432-DMZ](#) [CS42438-CMZ](#) [CS42448-CQZ](#) [CS42448-DQZ](#) [CS4244-CNZ](#) [CS4245-CQZ](#) [CS4265-CNZ](#) [CS4270-CZZ](#)