

DESCRIPTION

The PT2314E is an audio processor designed for versatile application, includes 4 stereo input selector with adjustable gain, master volume control with low frequency loudness compensation, speaker output attenuator and tone control. It is a good solution for the home audio signal processing.

Due to the high reliability requirement from the audio business, the PT2314E improves both audio performances and input surge current capability, these causes the PT2314E is the best solution for the cost-effective audio systems.

APPLICATIONS

- Flat Panel TV
- Home Audio System
- Powered Speaker System

FEATURES

- 4 stereo inputs with gain selection, range from 0dB to +11.25dB in 3.75dB/step
- Master volume from 0 dB to -78.75dB in 1.25dB/step
- Speaker attenuator for balance, range from 0dB to -38.75dB in 1.25dB/step
- Each channel output can be muted individually.
- Low frequency loudness compensation
- Bass and Treble control, range from -14dB to +14dB in 2dB/step
- Wide operation range (VDD=4V to 10V)
- Low harmonic distortion, low noise
- Improved and replace PT2314 and PT2314A

APPLICATION CIRCUIT

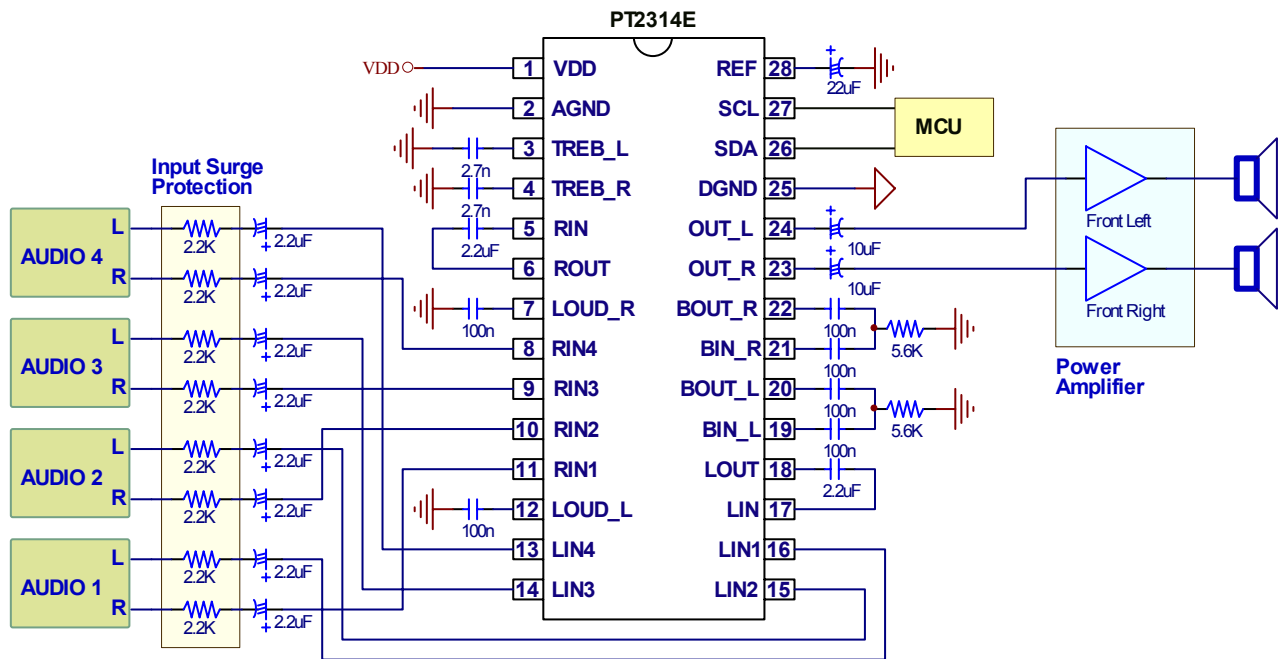

BLOCK DIAGRAM

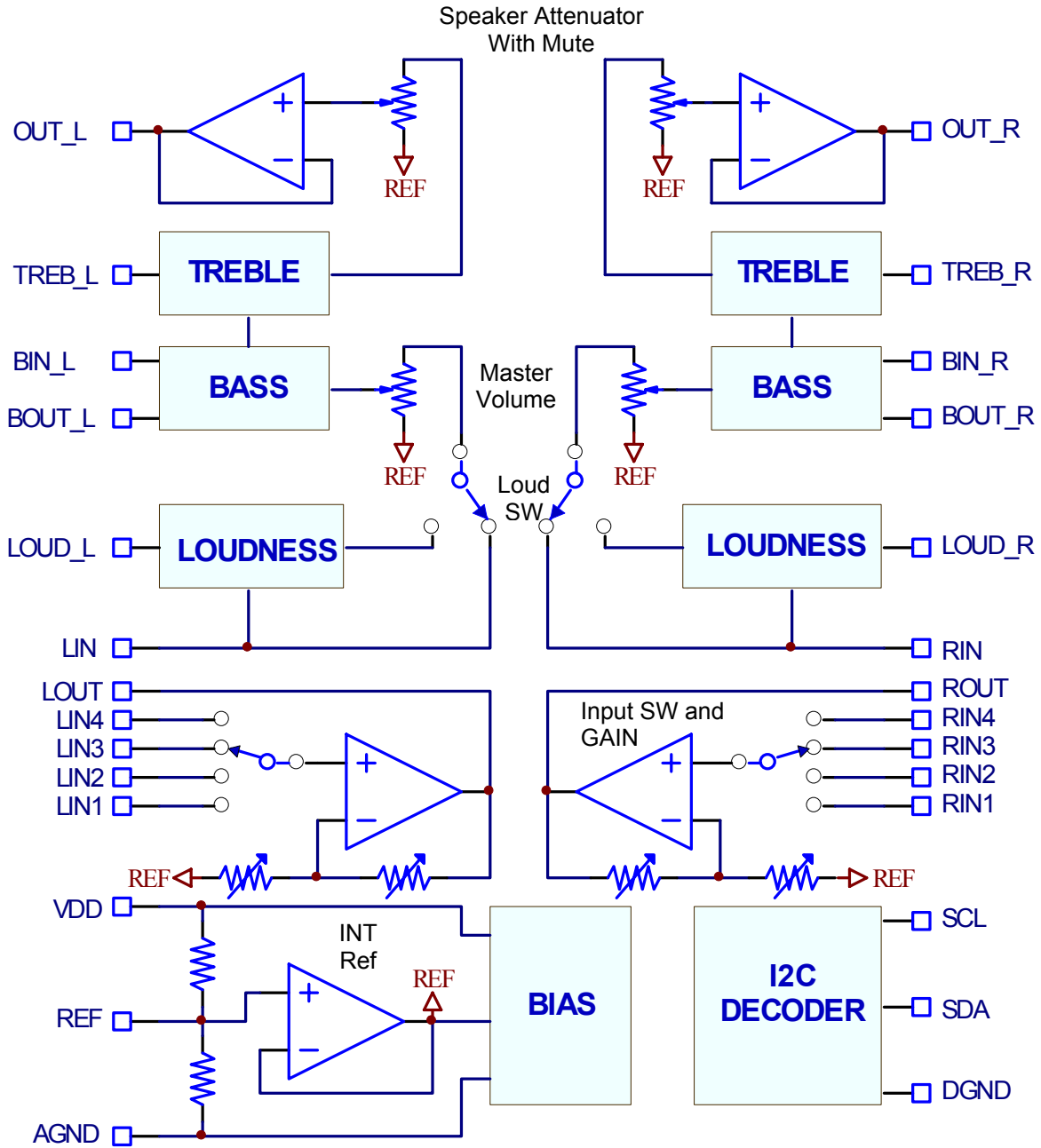

ORDER INFORMATION

Valid Part Number	Package Type	Top Code
PT2314E-S	28 Pins, SOP, 300mil	PT2314E

PIN CONFIGURATION

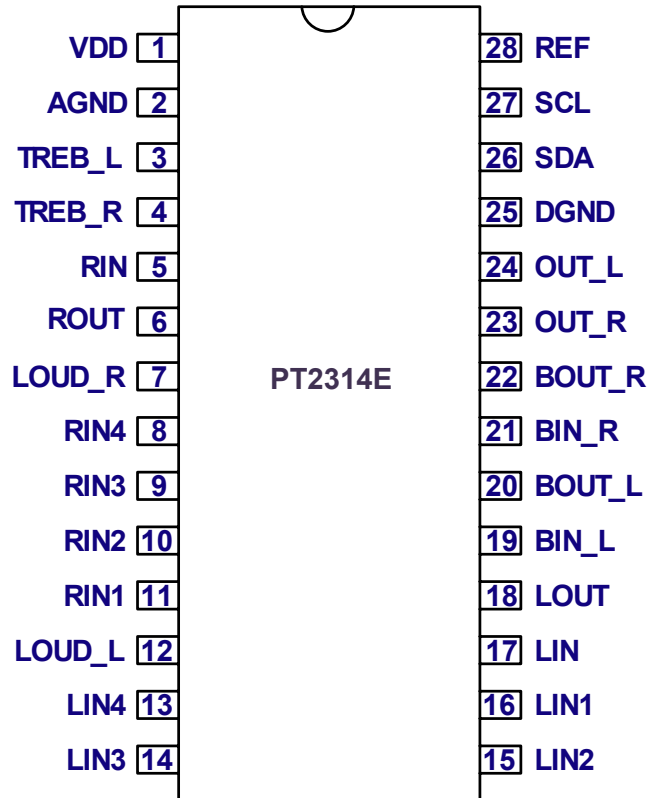

PIN DESCRIPTION

Pin Name	I/O	Description	Pin No.
VDD	-	Supply input voltage	1
AGND	-	Analog ground	2
TREB_L	I	Left channel input for treble controller	3
TREB_R	I	Right channel input for treble controller	4
RIN	I	Right channel volume controller input	5
ROUT	O	Right channel Input selector output	6
LOUD_R	I	Right channel loudness input	7
RIN4	I	Right channel input 4	8
RIN3	I	Right channel input 3	9
RIN2	I	Right channel input 2	10
RIN1	I	Right channel input 1	11
LOUD_L	I	Left channel loudness input	12
LIN4	I	Left channel input 4	13
LIN3	I	Left channel input 3	14
LIN2	I	Left channel input 2	15
LIN1	I	Left channel input 1	16
LIN	I	Left channel volume controller input	17
LOUT	O	Left channel Input selector output	18
BIN_L	I	Left channel input for bass controller	19
BOUT_L	O	Left channel output for bass controller	20
BIN_R	I	Right channel input for bass controller	21
BOUT_R	O	Right channel output for bass controller	22
OUT_R	O	Right channel output	23
OUT_L	O	Left channel output	24
DGND	-	Digital ground	25
SDA	I	I ² C data input	26
SCL	I	I ² C clock input	27
REF	-	Analog reference voltage (1/2VDD)	28

IMPORTANT NOTICE

Princeton Technology Corporation (PTC) reserves the right to make corrections, modifications, enhancements, improvements, and other changes to its products and to discontinue any product without notice at any time.

PTC cannot assume responsibility for use of any circuitry other than circuitry entirely embodied in a PTC product. No circuit patent licenses are implied.

Princeton Technology Corp.
2F, 233-1, Baociao Road,
Sindian, Taipei 23145, Taiwan
Tel: 886-2-66296288
Fax: 886-2-29174598
<http://www.princeton.com.tw>

X-ON Electronics

Largest Supplier of Electrical and Electronic Components

Click to view similar products for [Audio DSPs](#) category:

Click to view products by [Princeton](#) manufacturer:

Other Similar products are found below :

[AT85C51SND3B1-RTTUL](#) [BR281W31A101V1G](#) [SA3229-E1-T](#) [IA8201-RDI-01](#) [R3710-CEAA-E1](#) [CS48L10-CNZ](#) [CS48L10-CNZR](#)
[CS47024C-CQZ](#) [CS48L10-CWZR](#) [CS48L11-CNZ](#) [TAS3204PAGR](#) [BD37514FS-E2](#) [NJM2294V-TE1](#) [LC823450TA-2H](#) [LC823450XDTBG](#)
[ZL38052LDG1](#) [ADAU1450WBCPZ-RL](#) [ADAU1701JSTZ-RL](#) [ADAU1701JSTZ](#) [FSEIASLD-32G](#) [CI1103](#) [CS47048C-CQZ](#) [CS48560-DQZ](#)
[CS496102-CQZ](#) [CS181002-CQZ](#) [PT2399](#) [XD567](#) [XD1881](#) [TDA7440D013TR](#) [IA8201CQ](#) [SPK2611HM7H-1-2](#) [ALC662-VD0-GR](#)
[ALC662-GR](#) [CM108B](#) [CM118B](#) [HS-100B](#) [S1V30120F01A100](#) [CMX138AE1](#) [LC786820E-6E03-3H](#) [CMX823E4](#) [LC823455XATBG](#)
[LC89058W-E](#) [CM119BN](#) [CM6533N](#) [CM6530N](#) [THCV235-NNTA](#) [THCV236-NNTA](#) [XFS3031CNP](#) [BD37033FV-ME2](#) [BM28720MUV-E2](#)