

## DESCRIPTION

The PT2399 is a single chip echo processor IC utilizing CMOS technology. Which accept analog audio input signal, a high sample rate ADC transfer the analog signal into a bit stream then storage to internal 44Kbit RAM, after processing the bit stream will de-modulate by DAC and lowpass filter. Overall delay time is determined by internal VCO clock frequency, and user can easy to change the VCO frequency by changing the external resistance. The PT2399 performs low distortion (THD<0.5%@0.5Vrms) and low noise (No<-90dBV) characteristic for audio purpose, and pin arrangement and application circuit are optimized for easy PCB layout and cost saving advantage.

## FEATURES

- CMOS technology
- Least external components
- Auto reset Function prevent POP noise
- Low noise, SNR better than 90dB (typical)
- Low distortion, THD= 0.5%(typical)
- User adjustable VCO clock frequency.

## APPLICATIONS

- KARAOKE Mixer
- CD/DVD Player/Recorder
- Multimedia TV
- Car Entertainment System
- Music Instrument effector
- Electronics Toy

## BLOCK DIAGRAM

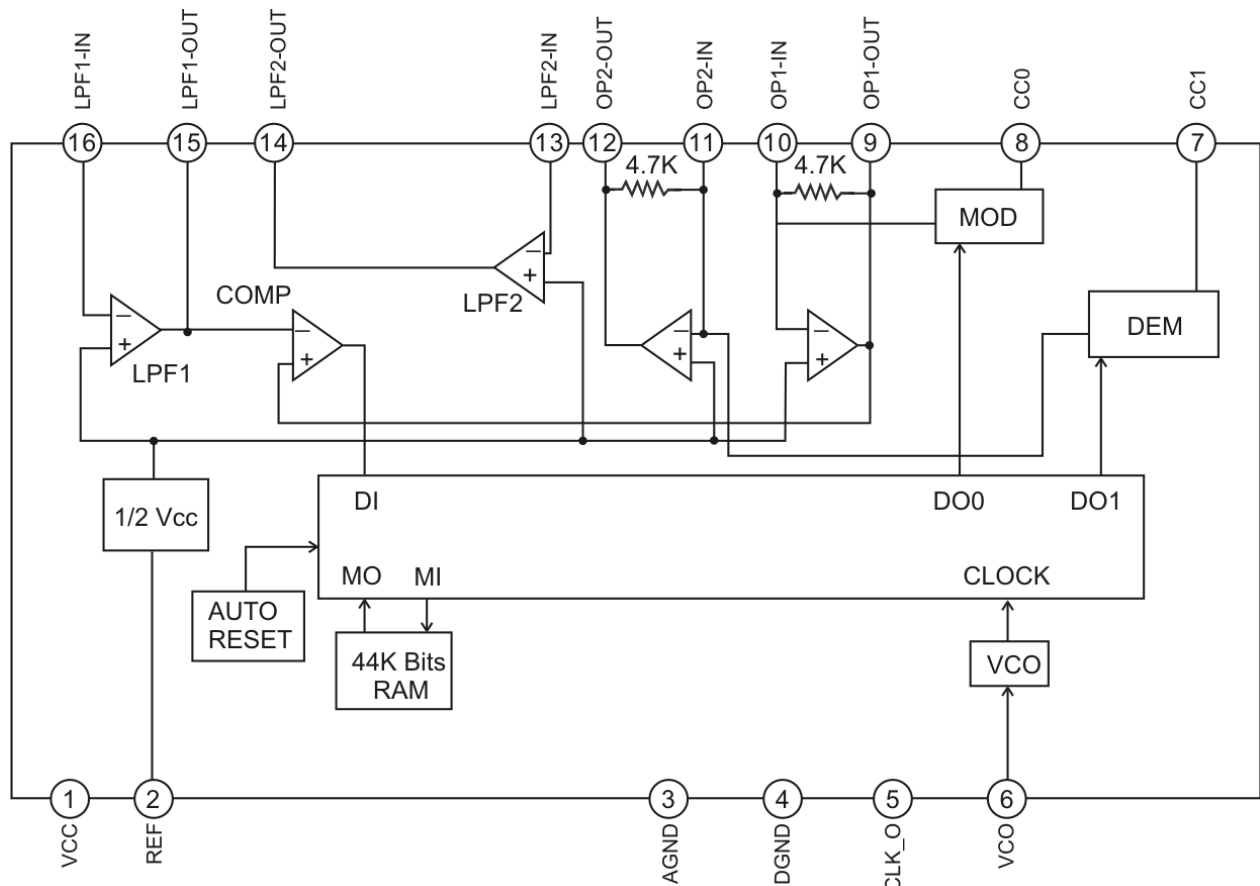

# APPLICATION CIRCUIT

## ECHO

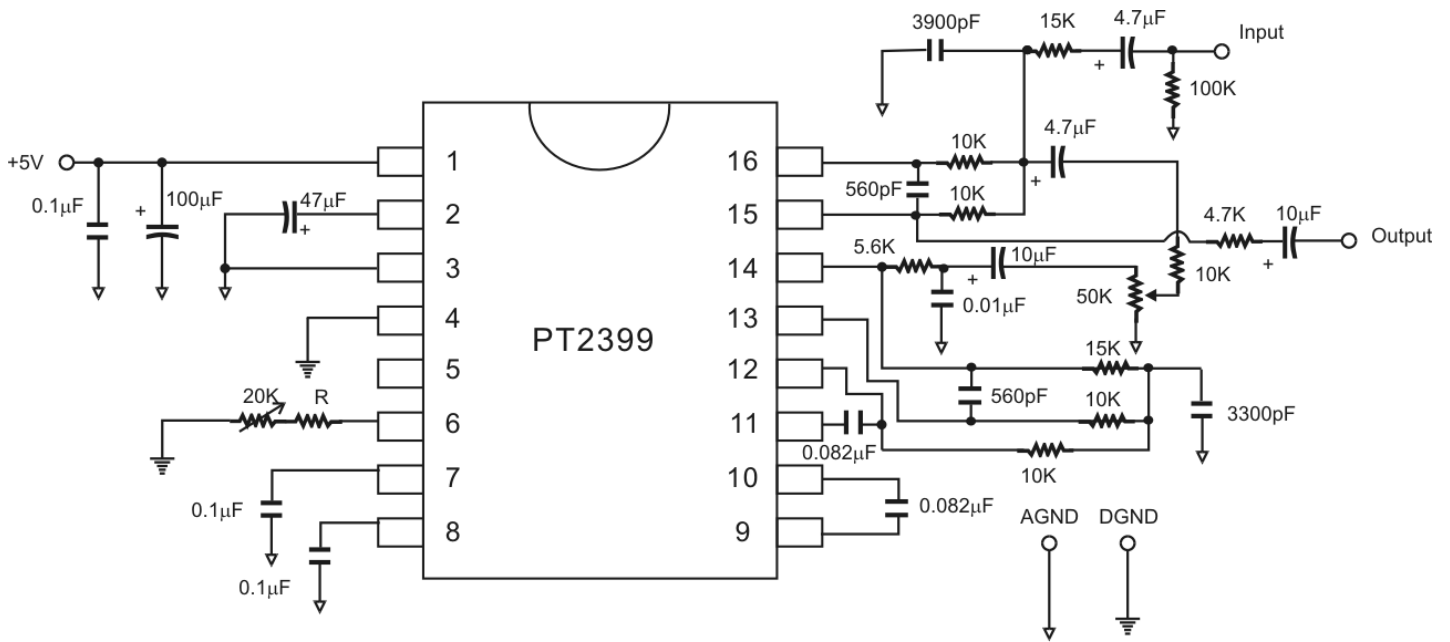

Note:  
 External Resistor having a value of 10 KΩ to 50 KΩ may be used. The recommended Resistor Value(R) is 10 KΩ. When the value of the Resistor (R) increases, the range of the Delay Time also increases.

## SURROUND/DELAY

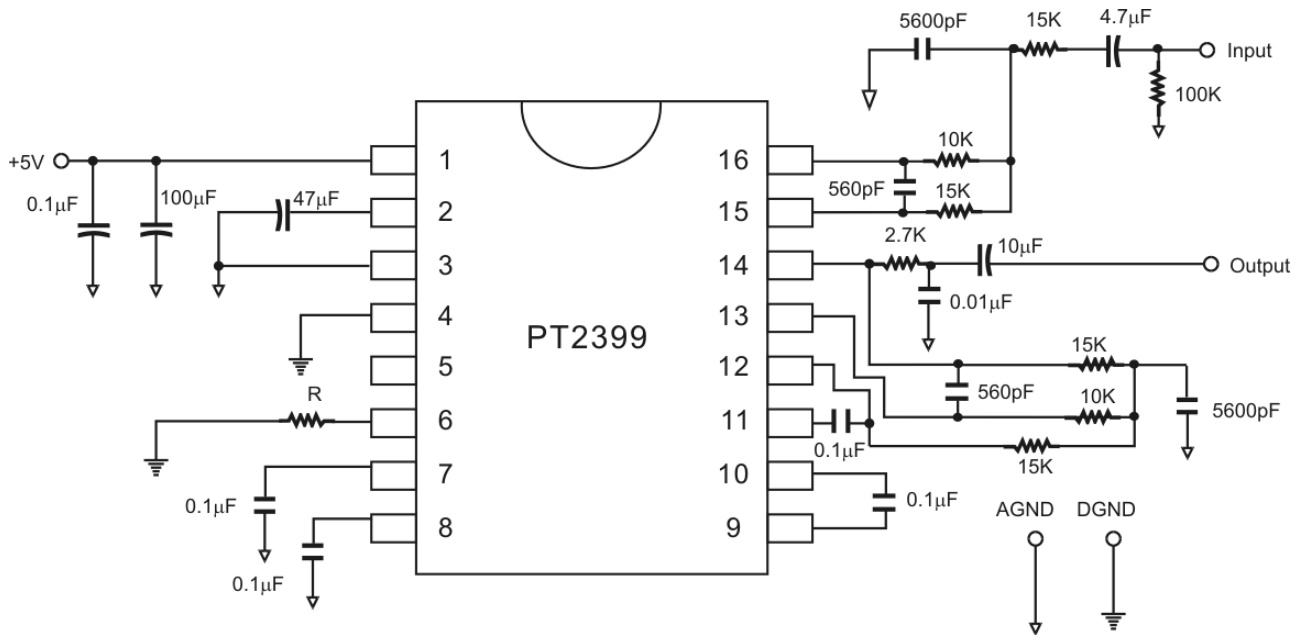

Note: Please refer to Table 1 for the Resistor/Delay Time values.

## ORDER INFORMATION

Valid Part Number	Package Type	Top Code
PT2399	16 Pins, DIP, 300mil	PT2399
PT2399S	16 Pins, SOP, 300mil	PT2399S
PT2399-SN	16 Pins, SOP, 150mil	PT2399-SN

## PIN CONFIGURATION

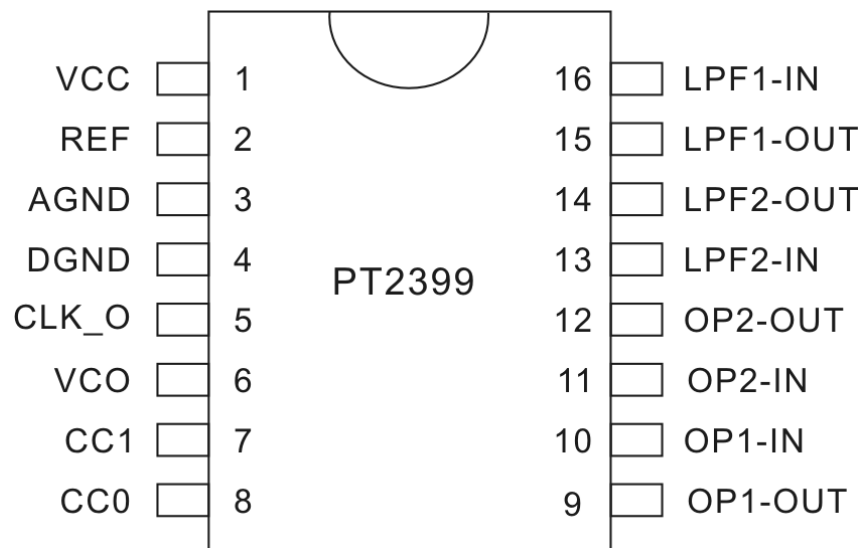

## PIN DESCRIPTION

Pin Name	I/O	Description	Pin No.
VCC	-	Analog supply voltage input	1
REF	-	Analog reference voltage (1/2VCC)	2
AGND	-	Analog ground	3
DGND	-	Digital ground	4
CLK_O	O	System clock output pin	5
VCO	I	VCO Frequency adjustment	6
CC1	-	Current control 1	7
CC0	-	Current control 0	8
OP1-OUT	O	OP amplifier 1 input/output. This pin can be used as modulated/Demodulated integrator by connecting capacitor	9
OP1-IN	I		10
OP2-IN	I	OP Amplifier 2 input/output. This pin can be used as Modulated/Demodulated Integrator by connecting Capacitor	11
OP2-OUT	O		12
LPF2-IN	I	Low pass filter 2 input/output pin	13
LPF2-OUT	O		14
LPF1-OUT	O	Low pass filter 1 input/output pin	15
LPF1-IN	I		16

## **IMPORTANT NOTICE**

Princeton Technology Corporation (PTC) reserves the right to make corrections, modifications, enhancements, improvements, and other changes to its products and to discontinue any product without notice at any time.

PTC cannot assume responsibility for use of any circuitry other than circuitry entirely embodied in a PTC product. No circuit patent licenses are implied.

Princeton Technology Corp.  
2F, 233-1, Baociao Road,  
Sindian, Taipei 23145, Taiwan  
Tel: 886-2-66296288  
Fax: 886-2-29174598  
<http://www.princeton.com.tw>

## X-ON Electronics

Largest Supplier of Electrical and Electronic Components

*Click to view similar products for [Audio DSPs](#) category:*

*Click to view products by [Princeton](#) manufacturer:*

Other Similar products are found below :

[AT85C51SND3B1-RTTUL](#) [BR281W31A101V1G](#) [SA3229-E1-T](#) [R3710-CEAA-E1](#) [CS48L10-CNZ](#) [CS48L10-CNZR](#) [CS47024C-CQZ](#)  
[CS48L10-CWZR](#) [CS48L11-CNZ](#) [BD37514FS-E2](#) [NJM2294V-TE1](#) [LC823450TA-2H](#) [LC823450XDTBG](#) [ZL38052LDG1](#)  
[ADAU1451WBCPZ](#) [ADAU1450WBCPZ](#) [ADAU1466WBCPZ300](#) [ADAU1452WBCPZ-RL](#) [AD1954YSTZ](#) [ADAU1701JSTZ-RL](#)  
[AD1940YSTZ](#) [ADAU1401AWBSTZ](#) [ADAU1702JSTZ](#) [FSEIASLD-32G](#) [CS47048C-CQZ](#) [CS48560-DQZ](#) [CS496102-CQZ](#) [PT2399](#) [XD567](#)  
[XD1881](#) [TDA7440D013TR](#) [LM4863G-N20-R](#) [IA8201CQ](#) [SPK2611HM7H-1-2](#) [ALC662-VD0-GR](#) [ALC662-GR](#) [CM108B](#) [HS-100B](#)  
[CM108AH](#) [S1V30120F01A100](#) [CMX138AE1](#) [LC786820E-6E03-3H](#) [CMX823E4](#) [LC823455XATBG](#) [THCV235-NNTA](#) [XFS3031CNP](#)  
[ZL38060LDG1](#) [BD37033FV-ME2](#) [BM28720MUV-E2](#) [WT588S-16S](#)