

DESCRIPTION

The PT2522 is a three-phase, sensor-less brushless DC motor control driver chip. The three-phase control is based on a square /trapezoidal wave control method that detects the zero-crossing of the motor back electromotive force (BEMF). It has a stable control and is not be affected by motor easily differences. The chip's soft-switching technology can achieve ladder or sinusoidal current waveforms, further reducing phase electromagnetic noise. The on-chip + 5V LDO provides operational operation for both logic and analog circuitry. It also integrates three 90V half-bridge gate drivers, making it ideal for gate drive of high-speed power MOSFETs and IGBTs in three-phase motor applications. The PT2522 provides a way to change internal parameter settings by burning to optimize different motors and applications. The package of the PT2522 is LQFP32.

FEATURES

- Sensor-less three-phase brushless DC motor control driver chip.
- Integrated three 90V half-bridge gate drivers.
- Driver pull-out/inrush current: 1200mA/2000mA.
- Built-in +5V LDO, 5V ~ 24V power supply.
- OTP burning motor control parameters.
- Set OTP parameters through I2C.
- Current limit and overvoltage protection.
- Temperature protection function (using external NTC resistor)
- Stall protection function
- PWM or DC input speed control.
- FG speed output.

APPLICATION

- Three-phase DC brushless motor
- High speed fan application
- Water pump application

BLOCK DIAGRAM

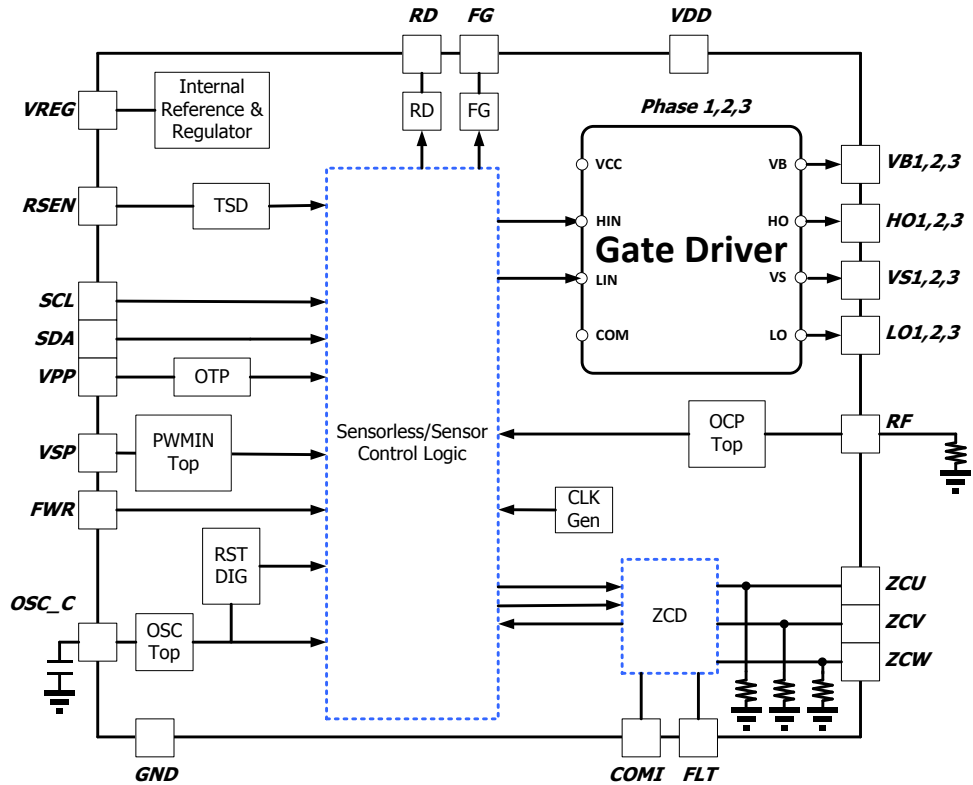

APPLICATION CIRCUIT

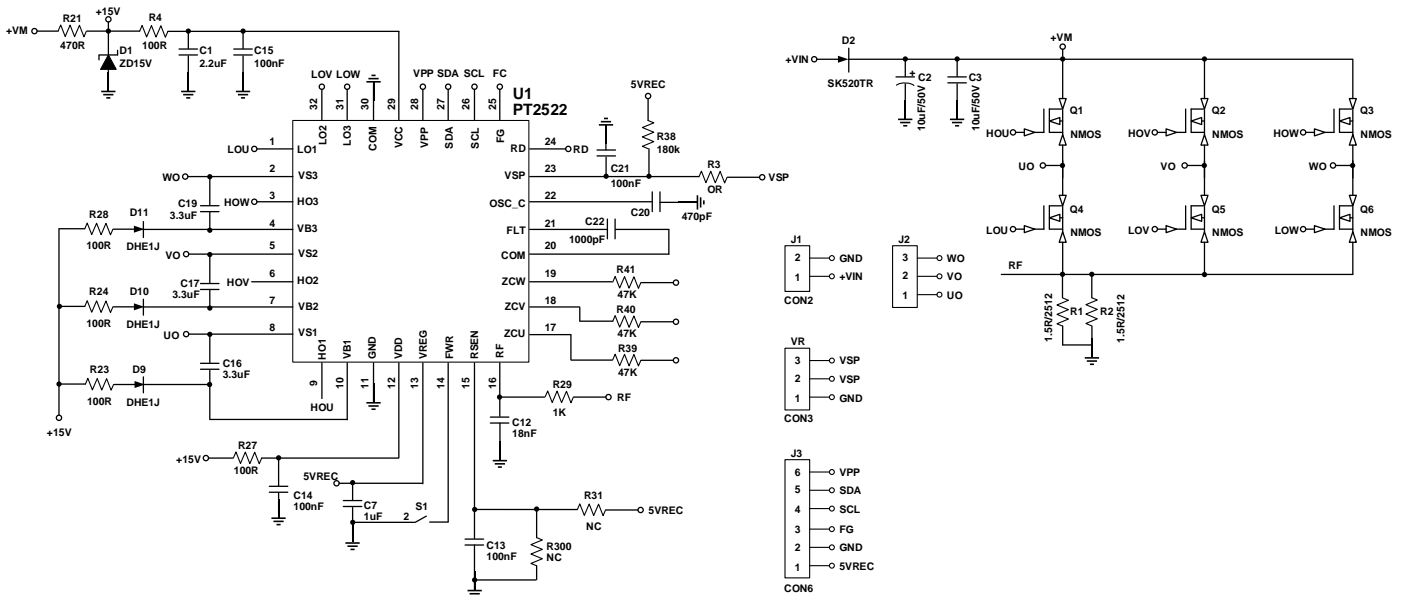

PIN CONFIGURATION

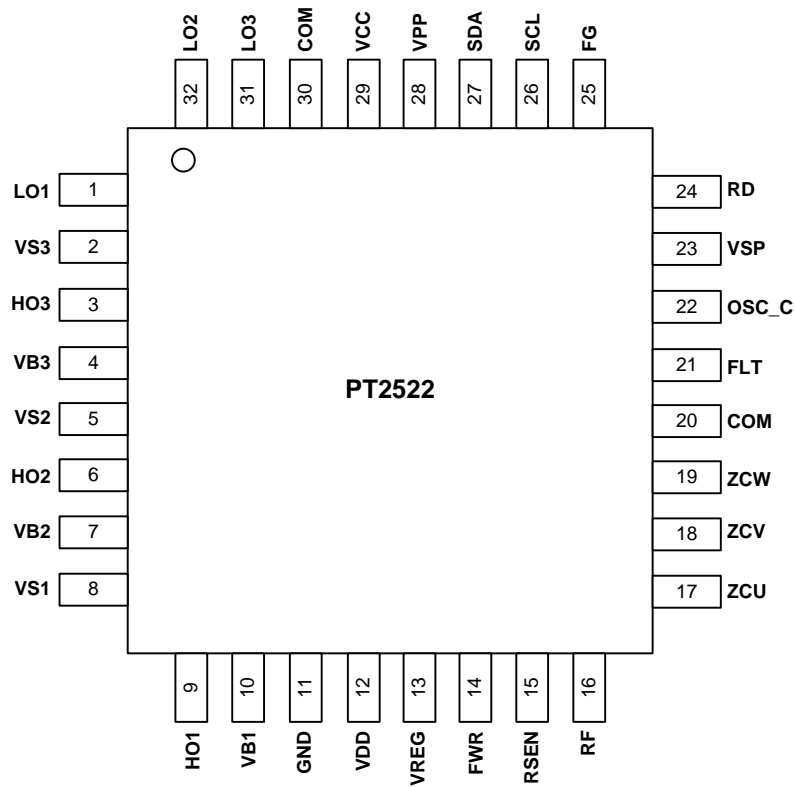

ORDER INFORMATION

Part Number	Package	Top Logo
PT2522-LQ	32 Pins, LQFP	PT2522-LQ
PT2522	32 Pins, QFN	PT2522

PINDESCRIPTION

Pin Name	I/O/P	Description	Pin No.
LO1	I/O	Phase 1 low side gate driver output	1
VS3	P	Phase 3 high side driver floating power supply swing voltage	2
HO3	I/O	Phase 3 high side driver output	3
VB3	P	Phase 3 high side driver floating power supply	4
VS2	P	Phase 2 high side driver floating power supply swing voltage	5
HO2	I/O	Phase 2 high side driver output	6
VB2	P	Phase 2 high side driver floating power supply	7
VS1	P	Phase 1 high side driver floating power supply swing voltage	8
HO1	I/O	Phase 1 high side driver output	9
VB1	P	Phase 1 high side driver floating power supply	10
GND	P	Signal ground	11
VDD	P	Voltage input	12
VREG	P	+5V voltage output	13
FWR	I	Positive and negative switching	14
RSEN	I	External NTC resistor can be connected as over temperature protection	15
RF	I	Current limiting voltage sensing	16
ZCU	I	U opposite electromotive zero-crossing input	17
ZCV	I	V opposite electromotive zero-crossing input	18
ZCW	I	W reverse electric zero-crossing input	19
COMI	I	Motor three-phase virtual neutral point	20
FLT	I	Six-step commutation signal filter input	21
OSC_C	IO	Connect an external capacitor as a triangular wave for PWM comparison	22
VSP	I	DC or PWM input speed control	23
RD	O	Stall protection indication output (5V CMOS logic)	24
FG	O	Speed indicator output (5V CMOS logic)	25
SCL	I	I2C Control Interface – Serial Frequency (Clock) Input	26
SDA	I/O	I2C Control Interface – Serial Data Input/Output	27
VPP	P	OTP Burning Power Input (7.5V)	28
VCC	P	Internal logic circuit and low side gate driver power input	29
COM	P	Internal logic circuit and low side gate driver power ground	30
LO3	I/O	Phase 3 low side gate driver output	31
LO2	I/O	Phase 2 low side gate driver output	32

FUNCTION DESCRIPTION

POWER SUPPLY

Since the PT2522 consumes very low current (<5mA) and has a 24V to 5V linear regulator (LDO) built in to provide logic and analog operation, there is no need to add an external 5V regulator for 6V to 24V applications. To avoid power supply interference or instability, the PT2522 internally detects the LDO voltage. When the LDO voltage exceeds 3.5V, the logic circuit will operate within 10ms. In the motor system, the chip is affected by induced noise easily, and the bypass capacitor is recommended to be placed as close to the IC power supply pin as possible.

When the power supply VM is between 6V~15V, PT2522 can connect to VM directly. When the VM voltage higher than 15V, it is suggested to use external voltage regulator to lower the voltage to 12V~15V and apply to VCC & VDD.

SENSOR-LESS CONTROL

The PT2522 control scheme is based on sensor-less trapezoidal wave control. The main benefit is that no Hall sensors needed, which in turn reduces module cost and temperature variations. Sensor-less feedback control is achieved by measuring the BEMF induced by the motor coil while the motor is rotating. When the motor is controlled, the UVW coil end voltage (phase voltage) mixes the control signal and BEMF, making it difficult to separate the back EMF from the phase voltage. When using a motor to commute, floating the motor for a period of time (a specific angle) is a way to obtain a back EMF signal. Under normal circumstances, the angle of the floating electrical device when the pure square wave is controlled is 60°, which is generally called 120° commutation control. The angle of the drifting electrical appliance during the trapezoidal wave control is 30° to 60°. There is also a commutation control called 150° when using a floating appliance angle of 30°.

The PT2522 uses a voltage divider resistor to reduce the phase voltage below 5V (the internal 10K field resistance), allowing the analog circuitry to process the signal and generate a zero-crossing (ZC) signal to sense the UVW commutation. Because the motor, operating voltage, speed and other factors cause system noise is too large or the motor's BEMF signal is too weak will affect the ZC signal accuracy, and this may lead to control failure, can be adjusted by analog filter (external capacitor) or digital filtering (internal parameters) to improve. The soft-switching of the PT2522 helps reduce audible motor current noise.

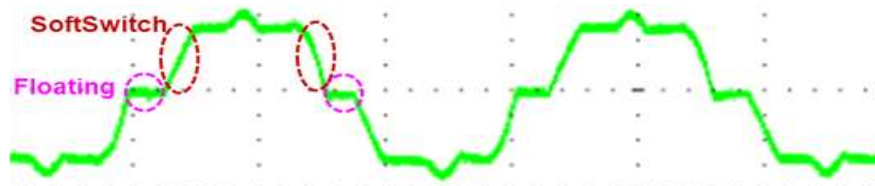

PT2522 commutation current wave pattern example

CURRENT LIMIT

The PT2522 uses a sense resistor to obtain a current-limiting function (at the RF pin) that is related to the relative phase current. When the detected RF voltage exceeds 0.3V, you can choose to reduce the PWM duty or turn off the PWM operation mode. RF resistors require high-power precision resistors to avoid burnout due to overheating. When the RF resistor is burned, it will cause an open circuit, which may cause extensive damage to components such as the controller, Gate Driver, and MOSFET.

CAPACITANCE SELECTION BETWEEN COMI AND FLT PINS

The PT2522 detects the motor position by comparing the back electromotive force generated by the motor rotation with the 3-phase virtual midpoint voltage to generate a ZC signal. However, noise from the start or rotation of the motor may interfere with the accuracy of the zero-crossing signal and may result in failure at startup or reduced motor efficiency. Capacitors between the COM and FLT pins help mitigate the effects of noise interference. The recommended range of capacitance values is 0.1nF to 10nF, because the filter capacitor also affects the judgment of the commutation delay. Therefore, the smaller the motor capacitor value, the higher the speed, the less the delay will affect. Alternatively, it also can set a digital filter by parameters. Whether digital or analog filters cause delays, the PT2522 can compensate for various delays through parameters, allowing the motor to maintain efficient operation.

OVER TEMPERATURE PROTECTION

The PT2522 uses an external negative temperature coefficient resistor (NTC) as the source of the over temperature protection detector. In the RSEN pin, the normal resistor will be connected to 5V and the NTC resistor will be connected to ground. The NTC resistor should be placed near a protected target such as a MOSFET. If the temperature rises, the NTC resistor value will decrease and the voltage level at the RESE pin will decrease. When the RSEN voltage is lower than 0.6V, the PT2522 enters the over-temperature protection (OTP) mode, pulls the RD pin high, and the system enters the shutdown mode. After the protection source is cooled, the voltage at the RSEN pin is higher than 1.2V and the motor system will start again. In the PT2522's shutdown mode, the UH / UL / VH / VL / WH / WL output logic level is low.

LOW SIDE POWER SUPPLY VCC AND UNDER VOLTAGE LOCKOUT (UVLO)

VCC is the low-side circuit power supply that provides the required drive energy for input logic and low-side output power stage operation. The built-in under voltage lockout circuit ensures that the chip operates at a high enough supply voltage range to prevent damage to the MOSFET/IGBT due to heat dissipation due to low drive voltage. As shown in Figure 1, when VCC rises and exceeds the threshold voltage $VCCUV+ = 4.2V$, the low-side control circuit is unlocked and starts to work, and LO starts to output; otherwise, VCC falls below the threshold voltage $VCCUV- = 3.8V$, low side The circuit is locked, the chip stops working, and the LO stops outputting. The VCC operating voltage range is recommended to be 10V-18V.

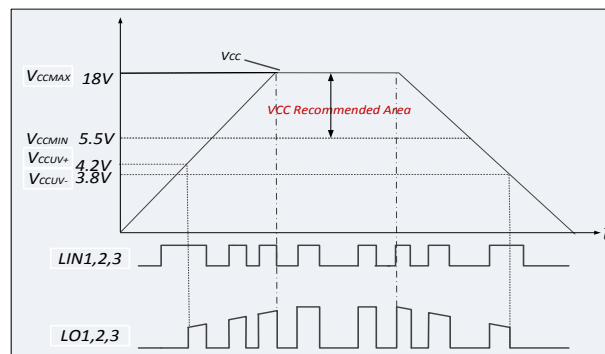

FIG.1 VCC supply UVLO operating area

HIGH SIDE POWER SUPPLY VBS (VB1-VS1, VB2-VS2, VB3-VS3) AND UNDER VOLTAGE LOCKOUT (UVLO)

The VBS power supply is a high-side circuit power supply, in which VBS1 (VB1-VS1), VBS2 (VB2-VS2) and VBS3 (VB3-VS3) correspond to phase 1, phase 2 and phase 3 high-side drive power supplies, respectively. The overall high-side circuit powered by the floating power supply VBS is referenced to ground COM and follows the source/emitter voltage of the external power transistor MOSFET/IGBT, swinging between ground and bus voltage. Since the high-side circuit has low quiescent current consumption, the entire high-side circuit can be powered by the bootstrap circuit technology connected to VCC, and only a small capacitor is required to maintain the voltage required to drive the power transistor. As shown in Figure 2, the under voltage lockout of the high-side power supply VBS is similar to the low-side VCC supply. The VBS operating voltage range is recommended to be 10V-18V.

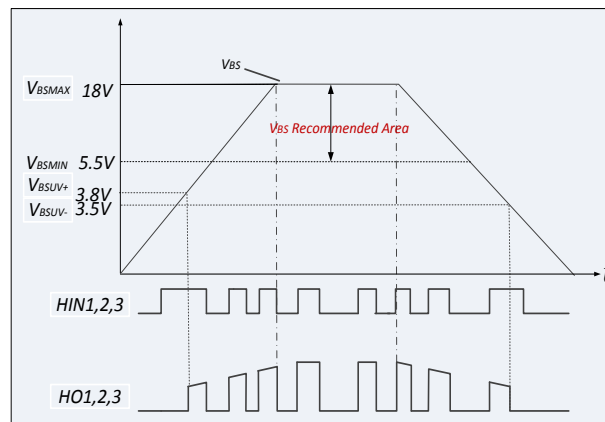
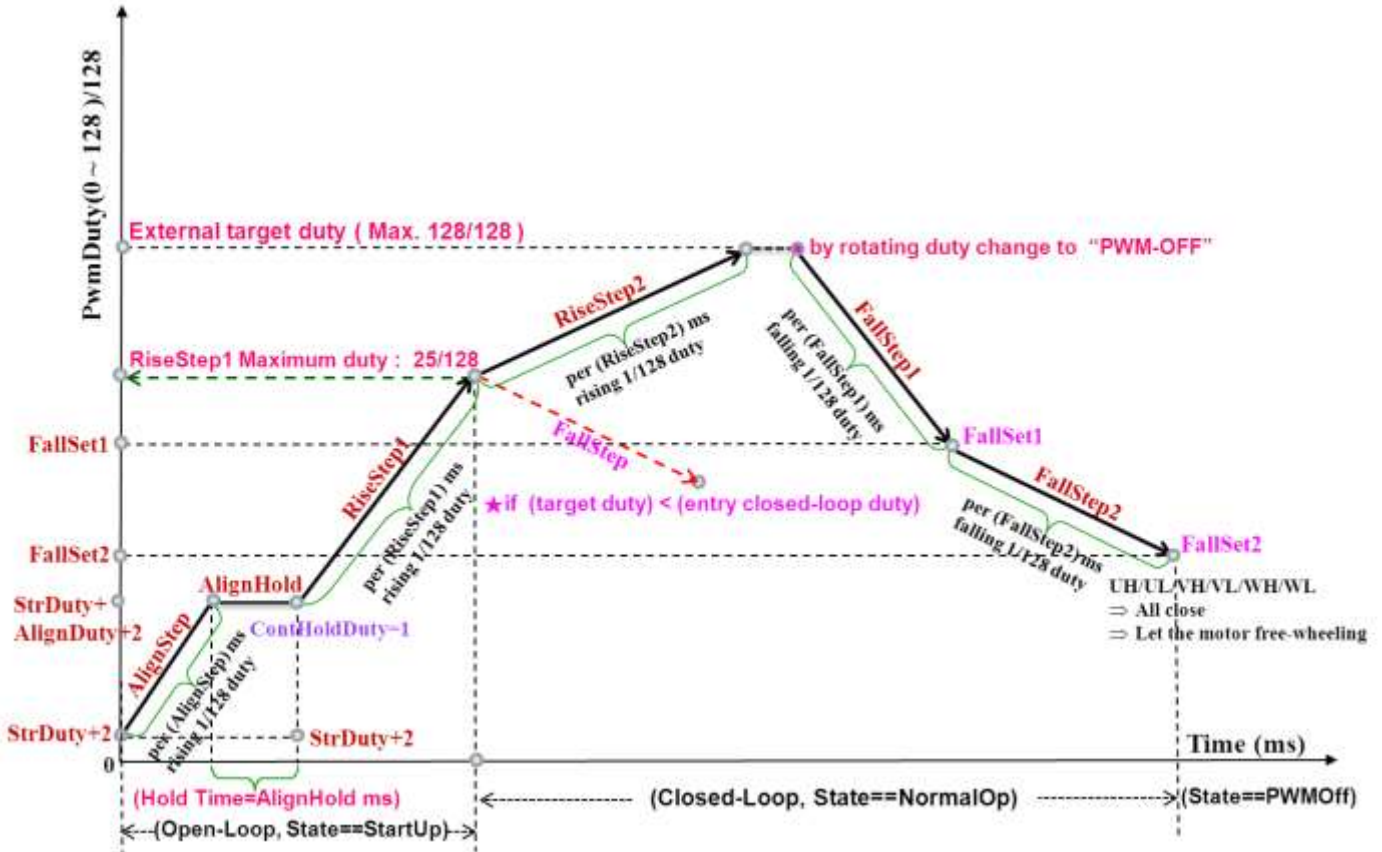

FIG.2 VBS supply UVLO operating area

PARAMETERS SETTING

In addition to overcurrent, overheat protection and zero-crossing signal filter of PT2522, it needs to be set by resistor and capacitor of external pin. The other parameters need to be adjusted and recorded in internal OTP memory through I2C, such as startup process and acceleration/deceleration time. And voltage backward compensation. When using OTP to burn, it is necessary to provide +7.5V to the VPP pin.

The figure below shows a schematic diagram of some parameters of PT2522. For detailed parameter description and adjustment method, please refer to PT2522_UI_Application_Note file.



PWM OR DC INPUT FOR SPEED CONTROL

The PT2522 can use an external DC voltage or PWM control input VSP pin to change the motor speed. When using the PWM input, the maximum voltage needs to be greater than 3.5V, the minimum voltage should be less than 0.3V, and the PWM frequency is recommended to be 15KHz to 25KHz.

When using DC control, the adjustable speed range is between 0.6V and 3.3V. When using an external MCU to control the PT2522, the FG signal provides speed information for speed control.

In addition, PT2522 can also accept I2C to input PWM duty command. In this case, please set VSP to 0.3V or less.

FORWARD AND REVERSE SETTING

The PT2522 can be set to enter the reverse mode either in the forward direction via the FR pin or parameter setting under the I2C mode. If the FR mode is changed, the motor will automatically stop and then rotate in the opposite direction.

I2C INTERFACE

The PT2522 can control or release parameters or perform OTP parameter recording via I2C. When parameter adjustment is made, the internal interface of the IC can be modified by using the USB interface of the NB/PC to the I2C mode. The connection mode is as follows:

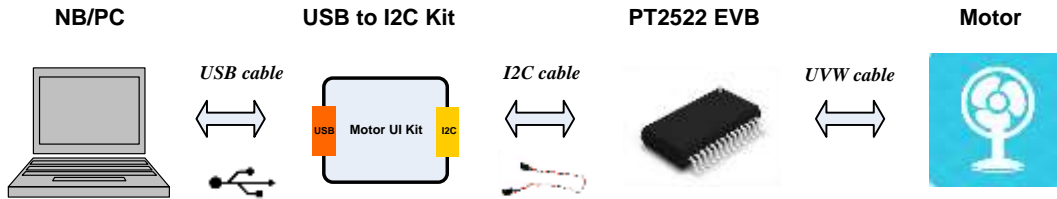

When the parameter adjustment of the IC register is performed through I2C, it does not affect the OTP recording, so it can be arbitrarily adjusted until it meets the requirements.

The adjusted parameters can be archived or burned. Please note that when the adjusted value is not recorded in the OTP of the IC, the register value will not be the value of the NB/PC end after the IC is re-powered, but there will be three cases:

1. When OTP bank0 & bank1 is blank, the register will be filled in by default.
2. When OTP bank0 has a value and bank1 is blank, the register will fill in the bank0 value.
3. When both OTP bank0 & bank1 have a value, the register will fill in the bank1 value.

I2C frequency specification is below

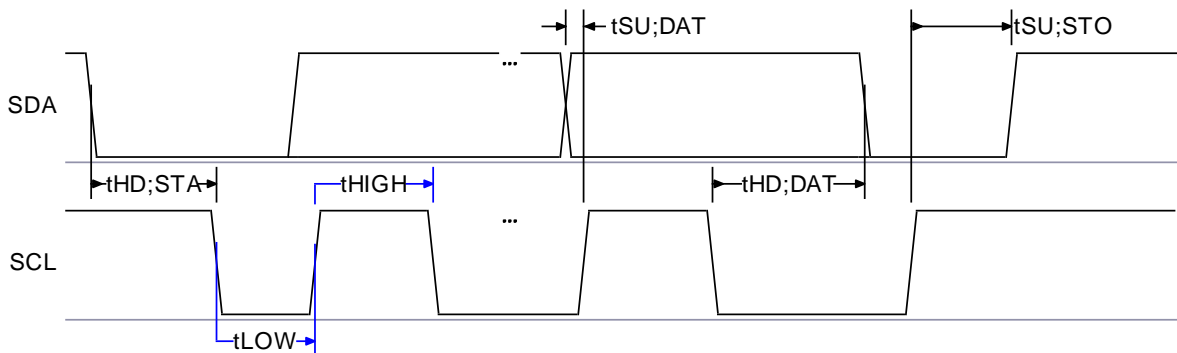

Parameter	Symbol	Condition	Min.	Max.	Unit
SCL clock frequency	f_{SCL}		0	50	KHz
Hold time START condition	$t_{HD;STA}$		4		μS
LOW period of the SCL clock	t_{LOW}		4.7		μS
HIGH period of the SCL clock	t_{HIGH}		4.0		μS
Data setup time	$t_{SU;DAT}$		250		nS
Data hold time	$t_{HD;DAT}$		5.0		μS
Setup time for STOP condition	$t_{SU;STO}$		4.0		μS

I2C DATA WRITE TIMING DIAGRAM

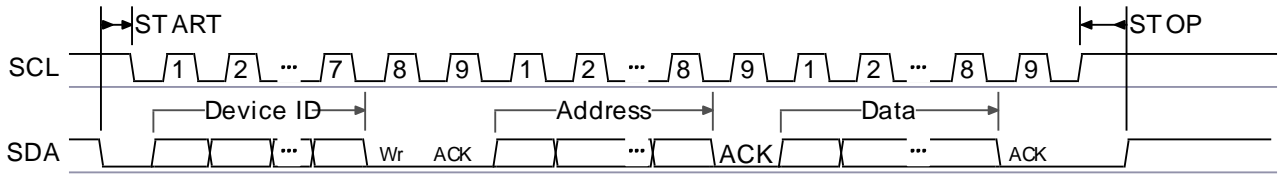

I2C DATA READ TIMING DIAGRAM

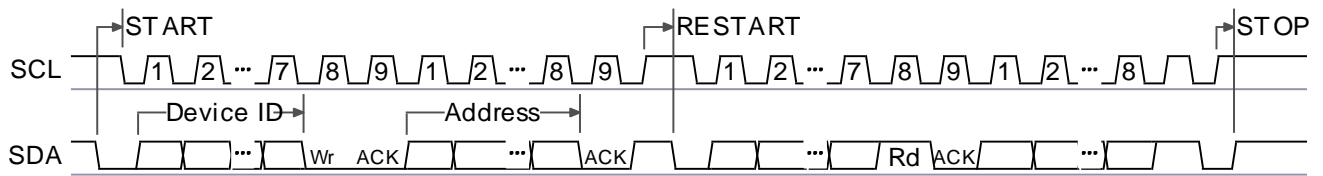

I2C READ / WRITE CONTROL

The commonly used I2C read/write command table (READ / WRITE COMMAND TABLE) is as follows:

Register map (address h00 ~ h04):

Bit							Address	Default			
7	6	5	4	3	2	1	0	Hex	Hex		
PWMS_EN							PWMS_EN	FWRS1_EN	FWRS0	0	0x00
PWM_I2C										1	0x00
FG_I2C[7:0]										2	0x00
Mstate[2:0]				FG_I2C[11:8]						3	0x00
RD			TSD		OVP		OCP		4	0x40	

Read /Write command table (address h00 ~ h04):

Address (HEX)	Bytes	Register	Description	Default (Hex)	(R/W)
0x00	Bit[7:3]	Reserved		0x00	
	Bit[2]	PWMS_EN	1: select PWM duty cycle via I2C (PWM_I2C[7:0]) 0: select PWM duty cycle via external VSP input		W
	Bit[1]	FWRS1_EN	1: forward/reverse control by I2C 0: forward/reverse control via external FWR input pin		W
	Bit[0]	FWRS0	Forward/reverse control 1: forward (default) 0: reverse		W
0x01	Bit[7:0]	PWM_I2C[7:0]	PWM duty command (written by I2C)	0x00	W
0x02	Bit[7:0]	FG_I2C[7:0]	FG frequency (read by I2C)	0x00	R
0x03	Bit[3:0]	FG_I2C[11:8]	Connect to 0x20 Bit[7:0]	0x00	R
0x04	Bit[7:5]	Mstate[2:0]	Motor system status: [000] : Startup state (Start-Up) [001] : Normal operation (Normal) [010] : Shutdown state (PWM-Off) [011] : Over temperature/voltage protection status (TSD/OVP) [100] : Stalled state (Lock-On) [101] : Deadlock state (Dead-Lock)	0x40	R
	Bit[4]	RD	1 : Enter protection status 0 : Normal operation		R
	Bit[3]	TSD	1 : Over temperature protection status 0 : Normal		R
	Bit[2]	OVP	1 : Overvoltage protection status 0 : Normal		R
	Bit[1]	OCP	1 : Overcurrent protection status 0 : Normal		R
	Bit[0]	Reserved			

I2C CONTROL PARAMETERS

The commonly used I2C control parameters are as follows:

Register Map (address h21 ~ h49):

Bit								Address Hex	Default Hex	
7	6	5	4	3	2	1	0			
AlignStep[7:0]								21	0x64	
AlignHold[7:0]								22	0x00	
RiseStep1[7:0]								23	0x64	
RiseStep2[7:0]								24	0x64	
DutySel	SmoothSel[1:0]		RiseStep2[8]		RiseStep1[8]		AlignHold[9:8]	AlignStep[8]	25	0xC0
FallStep2[8]	FallStep1[8]	SSWDegree[2:0]		HMOS		ContHoldDuty	OCPSEL	26	0x1E	
FallStep1[7:0]								27	0x32	
FallStep2[7:0]								28	0x64	
EnOVP	BrakeEndSet[2:0]			DeadTime[3:0]				29	0x33	
FallSet1[7:0]								2A	0x28	
FallSet2[7:0]								2B	0x12	
OCP BlankWidth[2:0]			ZCtarget[4:0]					2C	0x8F	
ZCCntMn[7:0]								2D	0xC8	
DigitalFilter[9:8]		ZCCntMn[13:8]						2E	0x00	
DigitalFilter[7:0]								2F	0xC0	
FilterDelay[7:0]								30	0xB8	
FilterDelay[15:8]								31	0x0B	
MinDuty[7:0]								32	0x05	
StartTimeLimit[3:0]				LockStopTime[3:0]				33	0x55	
DeadLock[7:0]								34	0x14	
StartStep1[7:0]								35	0xE8	
EnSpdCtrl	DeadLock[8]	StartStep1[13:8]						36	0x03	
StartStep2[7:0]								37	0x20	
ShortNum[1:0]		StartStep2[13:8]						38	0xC3	
LowFreqthd[1:0]		WaitTime[9:8]			FrFloating[3:0]			39	0x41	
WaitTime[7:0]								3A	0x0D	
EnFreqSpd	StrDuty[6:0]							3B	0x03	
PreMUXTime[1:0]		AlignDuty[5:0]						3C	0x86	
MaxDuty[7:0]								3D	0x80	
Div4	BrakeCountSet[6:0]							3E	0x7F	
PreCheckTime[7:0]								3F	0x7C	
FGLSel[1:0]		PreCheckTime[13:8]						40	0x41	
BrakeClkSel[1:0]		RevBrakeTime[5:0]						41	0x7C	
TrimA[7:0]								42	0x88	
TrimB[7:0]								43	0x88	
TrimC[7:0]								44	0xF0	
ZcTooLong[7:0]								45	0xC8	
ZcTooLong[11:8]				EnPreCheck		SpdSel[2:0]		46	0x0B	
ZCIgnoreTime[7:0]								47	0x80	
HysterSel[1:0]		ZCIgnoreTime[13:8]						48	0x42	
				ZCIgnoreSelect		ZCIgnorePhase[2:0]		49	0x01	

Parameter List (address h21 ~ h49):

Address (HEX)	Bytes	Register	Description	Default (Hex)
0x21	Bit[7:0]	AlignStep [7:0]	During the process of setting Align, the force is gradually increased to avoid excessive swing. Add 1/128 duty to each set time (AlignStep).	0x64
0x22	Bit[7:0]	AlignHold [7:0]	Set the duration of Align.	0x00
0x23	Bit[7:0]	RiseStep1 [7:0]	Set the slope of the start acceleration before entering the sensor-less control. Increase the RiseStep1 time by 1/128 duty and increase the maximum to 25/128 duty.	0x64
0x24	Bit[7:0]	RiseStep2 [7:0]	After setting the sensor-less control, the slope of the acceleration is increased by 1/128 duty per RiseStep2 time, and the maximum increase is to the externally set speed or the PWM duty clamped by the internal protection control.	0x64
0x25	Bit[7]	DutySelect	PWM duty processing selection, Default : 1. Set 1: The change of PWM duty output will be processed by the internal controller, and the ascending and descending curve can reach the progressive mode. Set 0: The PWM DUTY output change is not processed by the internal controller and is controlled by an external command.	0xC0
	Bit[6:5]	SmoothSel [1:0]	After entering sensor-less, if the ZC signal is too jittery, it will be judged to be abnormal and the system will enter the stall protection. Set the range of ZC jitter.	
	Bit[4]	RiseStep2 [8]	Connect to 0x24 Bit[7:0]	
	Bit[3]	RiseStep1 [8]	Connect to 0x23 Bit[7:0]	
	Bit[2:1]	AlignHold [9:8]	Set the duration of Align. Unit ms. Default : 0.	
	Bit[0]	AlignStep [8]	Connect to 0x21 Bit[7:0]	
0x26	Bit[7]	FallStep2 [8]	Connect to 0x28 Bit[7:0]	0x1E
	Bit[6]	FallStep1 [8]	Connect to 0x27 Bit[7:0]	
	Bit[5:3]	SSWDegree [2:0]	Set the Soft-Switch angle setting. The larger the SSWDegree angle, the shorter the floating time angle will be.	
	Bit[2]	High-Side MOS	High MOS polarity setting, Default : 1. Set 1: Positive logic, Set 0: Negative logic.	
	Bit[1]	ContHoldDuty	When AlignHold is finished, set whether to extend the power of Align as the starting force for starting. Default : 1. Set 0: RiseStep1 Duty starts with (StrDuty+2) Set 1: RiseStep1 Duty to continue Duty after the end of HoldTime.	



Address (HEX)	Bytes	Register	Description	Default (Hex)
	Bit[0]	OCPSel	The PT2522 uses the voltage signal on the RF pin to detect the current flowing through the motor and MOS. When the voltage exceeds the set value, the PT2522 will reduce the PWM duty as an overcurrent or current limit protection. When the PWM duty is lowered, the reaction speed can be selected. . Default : 0. Set 1: The reaction rate is 20KHz (0.5us), the reaction is fast, but there may be electronic noise. Set 0: The reaction rate is one electrical cycle (or ZC cycle), the reaction is slow, and there is no electronic noise due to OCP.	
0x27	Bit[7:0]	FallStep1 [7:0]	The first slope of the PWM Duty is reduced by 1/128 duty per (FallStep1) ms.	0x32
0x28	Bit[7:0]	FallStep2 [7:0]	The second slope of the PWM Duty is reduced by 1/128 duty per (FallStep2) ms.	0x64
0x29	Bit[7]	EnOVP	Enable OVP function, Default : 0. Set 1: For overvoltage protection, when an overvoltage occurs, the System enters the Lock-On State. Set 0: To cancel the overvoltage protection function.	0x33
	Bit[6:4]	BrakeEndSet [2:0]	Setting the ZC length of the upwind brake to the quick stop, Default : 3 . Set 0: 7.8ms, Set 1: 15.6ms, Set 2: 23.4ms, Set 3: 31.2ms, Set 4: 39ms, Set 5: 46.8ms, Set 6: 54.6ms, Set 7: 70.2ms. Then start the Alignment program.	
	Bit[3:0]	DeadTime [3:0]	The unit is a clock-cycle (0.39us), Default: 3.	
0x2A	Bit[7:0]	FallSet1 [7:0]	The interval value of the two-slope slope of the PWM Duty is reduced. From the beginning of this value, the second-stage down-slope is used.	0x28
0x2B	Bit[7:0]	FallSet2[7:0]	If the PWMOFF or FWR reverse command is executed during operation, the PWM Duty is reduced to the Duty setting of the coasting (six MOS fully closed) state.	0x12
0x2C	Bit[7:5]	OCP_BlankWidth [2:0]	Since the PWM signal is generated when the PWM is switched, and the switching noise could be filtered by an external low-pass filter. It can also be controlled internally to avoid this time, thus ensuring that the correct OCP signal can be read. This time is OCP blank. 0~4 clock-cycle (0.39us) can be set. When set to 0, the OCP blank function is canceled, Default : 4.	0x8F
	Bit[4:0]	ZCTarget [4:0]	It is set that during the starting process, the correct number of ZCs are read and the system will be close to the sensor-less control. Recommended value is 10~25, Default : 15 .	



Address (HEX)	Bytes	Register	Description	Default (Hex)
0x2D	Bit[7:0]	ZCCntMn [7:0]	After entering sensor-less, if the ZC signal is too short, it will determine that it is not normal, and the system enters the stall protection. Set the ZC minimum time, the unit clock-cycle (0.39us).	0xC8
0x2E	Bit[7:6]	DigitalFilter [9:8]	Connect to0x2F BIT[7:0]	0x00
	Bit[5:0]	ZCCntMn [13:8]	Connect to0x2D BIT[7:0]	
0x2F	Bit[7:0]	DigitalFilter [7:0]	Set the width of the ZC signal digital filter (de-glitch). The unit is a clock-cycle (0.39us), Default: 192.	0xC0
0x30	Bit[7:0]	FilterDelay [7:0]	It is the delay time corresponding to the "External Circuit Filter Capacitor" + "Digital Filter". If this "Filter Delay" value is adjusted, the current waveform will be more stable than the symmetric ZC, and the efficiency control will be optimal. The unit is a clock-cycle (0.39us), Default : 3000.	0xB8
0x31	Bit[7:0]	FilterDelay [15:8]		0x0B
0x32	Bit[7:0]	MinDuty [7:0]	Limit the minimum duty of PWMIN, in units of 1/128 duty. The maximum setting is 64/128. When the input PWM duty is less than minDuty, it is PWM OFF, Default : 5.	0x05
0x33	Bit[7:4]	StartTimeLimit [3:0]	At startup, enter the sensor-less time limit, in seconds, default: 5. The setting range is 1~15 seconds. If sensor-less is not entered within the time, it will enter Lock-On State.	0x55
	Bit[3:0]	LockStopTime [3:0]	The wait time setting when the System State enters the stall protection. Unit seconds, Default : 5. The setting range is 1~15 seconds.	
0x34	Bit[7:0]	DeadLock [7:0]	The number of times Lock-On State is locked to the lock state, in units of Lock-On. That is, how many times Lock-On stops, it will lock the machine, you must re-plug the power to release.	0x14
0x35	Bit[7:0]	StartStep1 [7:0]	During the start-up process, the correct ZC signal has not yet appeared, and the length of the step is forced to change.	0xE8
0x36	Bit[7]	EnSpdCtrl	Enable PWM-Duty Speed Control, default : 0, This enable is only useful when "enFreqSpd" is 0. This is the second level control command. Set 1: PWM IN is the fixed speed command controlled by Duty. Set 0: When enFreqSpd is also 0, PWM IN is the original Duty command.	0x03
	Bit[6]	DeadLock [8]	Connect to0x34 Bit[7:0]	
	Bit[5:0]	StartStep1 [13:8]	Connect to0x35 Bit[7:0]	
0x37	Bit[7:0]	StartStep2 [7:0]	During the start-up process, the ZC appears, but the length of the step is forced to change when the sensor-less control condition has not been reached. Unit ms, Default : 800.	0x20



Address (HEX)	Bytes	Register	Description	Default (Hex)
0x38	Bit[7:6]	ShortNum [1:0]	Since the ZC may be disturbed when it is too short, this parameter is set to be continuous. If the number of ZCs is too short, it is determined that the state is blocked. Set 0: disable , not judge, Set 1: Detect once, Set 2: detect two consecutive times, Set 3: Detected three times in succession.	0xC3
	Bit[5:0]	StartStep2 [13:8]	Connect to 0x37 Bit[7:0]	
0x39	Bit[7:6]	LowFreqthd	Low Frequency Threshold, the lowest frequency limit entered during the frequency speed control command. When the input control frequency is less than the "LowFreqThd" setting value, it is Frequency OFF, Default : 1. Set 0: 1Hz, Set 1: 5Hz, Set 2: 10Hz, Set 3: 20Hz.	0x41
	Bit[5:4]	WaitTime 9:8]	Connect to 0x3A Bit[7:0]	
	Bit[3:0]	FrFloating [3:0]	When the FWR reverse command is executed, and FallSet2 is executed, the fan coasts down to the fast stop (ZC does not change for 0.3 seconds), and the buffer time setting for starting in the reverse direction is prepared.	
0x3A	Bit[7:0]	WaitTime [7:0]	The PT2522 uses square wave control (120 degree control) during start-up. This is the delay time to change the trapezoidal wave control after entering the sensor-less control, so that the sensor-less control is more stable. WaitTime is 32ms per unit, Default : 13, which is 416ms.	0x0D
0x3B	Bit[7]	EnFreqSpd	Enable Frequency Speed Control, default : 0, This is the highest control command. Set 1: Speed control command for frequency input, Set 0: The fixed speed command controlled by Duty or the original PWM Duty command.	0x03
	Bit[6:0]	StrDuty [6:0]	Set the initial force to overcome the static friction of the motor. This parameter is used in Alignment & Startup. Unit 1/128 duty, Default: 3.	
0x3C	Bit[7:6]	PreMUXTime [1:0]	Set the time to check the U, V, W three-phase in turn, to determine whether the motor is in forward or reverse rotation, Default : 2.	0x86
	Bit[5:0]	AlignDuty [5:0]	Set the maximum force of Align, unit 1/128 duty. Maximum 31/128 duty. Default : 6	
0x3D	Bit[7:0]	MaxDuty [7:0]	Limit the maximum duty of PWMIN in units of 1/128 duty. The minimum setting is 64/128. When the input PWM duty is greater than maxDuty, the output is maxDuty,Default : 128 °	0x80
0x3E	Bit[7]	Div4	Input Frequency Divided by 4 , Default : 0 ° Set 1: The input frequency is four times the FG output frequency. Set 0: The input frequency is the same as the FG output frequency.	0x7F



Address (HEX)	Bytes	Register	Description	Default (Hex)
	Bit[6:0]	BrakeCountSet [6:0]	Set the time interval between breaks (resting), which is a multiple of BrakeClkSel (1~127), Default: 127.	
0x3F	Bit[7:0]	PreCheckTime [7:0]	Set the maximum time for the PreCheck program to start upwind.	0x7C
0x40	Bit[7:6]	FGLSel [1:0]	FG output frequency setting, unit Hz, Default : 1 . Set 0: FG output is the FG frequency divided by 2, Set 1: For normal FG frequency, if it is 8 poles motor, the speed is (15 * FG frequency) rpm, Set 2: FG output is the FG frequency multiplied by 2. Set 3: FG output be the FG frequency multiplied by 3.	0x41
	Bit[5:0]	PreCheckTime [13:8]	Connect to 0x3F Bit[7:0]	
0x41	Bit[7:6]	BrakeClkSel [1:0]	When the headwind is detected, the PT2522 will stop and restart first. The brake adopts the point brake method, and the time is longer than the one brake, such as the first brake for 1ms, the second time for 2ms, the third time. It is 3ms, and so on until the motor stops. BrakeClkSel is the unit time for setting the brake, Default : 1 (500us). Set 0: 100us, Set 1:500us, Set 2: 1ms, Set 3: 2ms.	0x7C
	Bit[5:0]	Reserved		
0x42	Bit[7:0]	Reserved		0x88
0x43	Bit[7:0]	Reserved		0x88
0x44	Bit[7:0]	Reserved		0xF0
0x45	Bit[7:0]	ZcTooLong [7:0]	After entering sensor-less, if the ZC signal is too long, it will judge that it is not normal, and the system enters the stall protection. Set the ZC for the longest time.	0xC8
0x46	Bit[7:4]	ZcTooLong [11:8]	Connect to 0x46 Bitp7:0]	0x0B
	Bit[3]	EnPreCheck	Default : 1 ° Set 1: There is a forward wind start detection procedure Set 0: No forward wind start detection procedure	
	Bit[2:0]	SpdSel [2:0]	Select the FG frequency range of the fixed speed command with PWM-Duty control, Default : 3. Set 0: 16Hz, Set 1:32Hz, Set 2: 64Hz, Set 3: 128Hz, Set 4: 256Hz, Set 5: 512Hz, Set 6: 1024Hz, Set 7: 2048Hz	
0x47	Bit[7:0]	ZCIgnoreTime [7:0]	For the fixed time in the ST1 & ST2 formula, the unit is a clock-cycle (0.39us), Default : 640.	0x80

Address (HEX)	Bytes	Register	Description	Default (Hex)
0x48	Bit[7:6]	HysterSel [1:0]	The PT2522 provides constant speed control (speed closed loop control). The command input can use Frequency (or Clock), PWM duty, VSP voltage. The same is required for the hysteresis parameter. Set the frequency or the hysteresis angle of the PWM-Duty fixed speed command. Hysteresis Select ,Default : 1 . Set 0: no hysteresis, Set 1: Hysteresis 0.23 degrees, Set 2: Hysteresis 0.47 degrees, Set 3: hysteresis of 0.94 degrees.	0x42
	Bit[5:0]	ZCIgnoreTime [13:8]	Connect to 0x47 Bit[7:0]	
0x49	Bit[7:4]	Reserved		0x01
	Bit[3]	ZCIgnoreSelect	When the motor is commutating, the ZC signal is unstable at this time, and it is necessary to avoid this time. The PT2522 provides two formula options to set the blanking time, Default : 0.	
	Bit[2:0]	ZCIgnorePhase [2:0]	For the angle selection in the formula, Default : 1 => 3.75 degrees. Set 0: 1.875 degrees, Set 1: 3.75 degrees, Set 2: 7.5 degrees, Set 3: 11.25 degrees, Set 4:15 degrees, Set 5: 18.75 degrees, Set 6: 20.625 degrees, Set 7: 22.5 degrees.	

ABSOLUTE MAXIMUM RATINGS

Parameter	Symbol	Min	Max.	Unit
V _{DD} supply voltage	V _{DD}	5	28	V
High-side floating supply voltage	V _{B1,2,3}	-0.3	90	V
High-side floating supply offset voltage	V _{S1,2,3}	V _{B1,2,3} -20	V _{B1,2,3} +0.3	V
High-side gate driver output voltage	V _{HO1,2,3}	V _{S1,2,3} -0.3	V _{B1,2,3} +0.3	V
Low-side gate driver output voltage	V _{LO1,2,3}	COM-0.3	V _{CC} +0.3	V
Low-side supply voltage	V _{CC}	-0.3	20	V
Allowable offset voltage slew rate	dV/dt	—	50	V/ns
Input/Output voltage	-	-0.3	6	V
Operating temperature	T _A	-40	+ 85	°C
Storage temperature	T _{STG}	-40	+150	°C

ELECTRICAL CHARACTERISTIC

VDD = 12.0V, SGND = VSS, TA = + 27°C unless otherwise specified

Parameter	Symbol	Conditions	Min	Typ	Max	Unit
General						
VDD supply voltage	V _{DD}	VDD input	6	12	24	V
Low-side supply voltage	V _{CC}		5.5	—	18	V
High-side floating supply offset voltage	V _{S1,2,3}		COM-6	—	60	V
High-side floating supply voltage	V _{B1,2,3}		V _{S1,2,3} +5.5	—	V _{B1,2,3} +18	V
High-side gate driver output voltage	V _{HO1,2,3}		VS	—	VB	V
Low-side gate driver output voltage	V _{LO1,2,3}		COM	—	VCC	V
Power supply current	I _{DD}	VDD = 12V		5		mA
Regulator output voltage	V _{REG}		4.75	5	5.25	V
Regulator output current	I _{REG}			20		mA
Pin parameter setting						
Over current protection voltage	V _{OCP}	RF pin		0.3		V
External oscillator	F _{OSC_1K}	OSC_C= 470pF		1		KHz
External oscillator frequency range	F _{OSC_C}	OSC_C pin	0.1	-	10	KHz
Operation Characteristics						
PWM switching frequency	F _{sw}			20		KHz
I/O interface						
Logic output high level	V _{OH}	UVWL, UVWH, FG, RD	4.0	4.5	5.5	V
Logic output low level	V _{OL}	UVWL, UVWH, FG, RD		0	0.3	V
Logic input pull high current	I _{source}	FR			10	μA
RSEN internal pull high resistance	R _{SEN}	RSEN pin, connect to V _{REG}		47		KΩ
VSP DC for control range	V _{SPDC}	DC input (VSP pin)	0.3		3.0	V
VSP input high level for PWM	V _{SPH}	PWM input (VSP pin)	3.3			V
VSP input low level for PWM	V _{SPL}	PWM input (VSP pin)			0.3	V
VSP input frequency range for PWM	V _{SPF}	PWM input (VSP pin)	15		25	KHz
Parameter Setting						
Over temperature protection trigger level	V _{OTP}	RSEN pin	—	0.6	—	V
Over temperature protection reset level	V _{REL}	RSEN pin	—	1.2	—	V
Low Side Power Supply Characteristics						
VCC supply under-voltage positive going threshold	V _{CCUV+}	—	2.9	4.2	5.5	V
VCC supply under-voltage negative	V _{CCUV-}	—	2.5	3.8	5.1	V

Parameter	Symbol	Conditions	Min	Typ	Max	Unit
going threshold						
VCC supply under-voltage lockout hysteresis	V_{CCHYS}	—	—	0.4	—	V
High Side Floating Power Supply Characteristics						
High side VBS supply under-voltage positive going threshold	V_{BSUV+}	—	2.5	3.8	5.5	V
High side VBS supply under-voltage negative going threshold	V_{BSUV-}	—	2.2	3.5	4.8	V
High side VBS supply under-voltage lockout hysteresis	$V_{BSUVHYS}$	—	—	0.3	—	V
Gate Driver Characteristics						
High side output HIGH short-circuit pulse current	I_{HO+}	$V_{HO}=V_S=0$	—	1.2	—	A
High side output LOW short-circuit pulse current	I_{HO-}	$V_{HO}=V_B=15V$	—	2.0	—	A
Low side output HIGH short-circuit pulse current	I_{LO+}	$V_{LO}=0$	—	1.2	—	A
Low side output LOW short-circuit pulse current	I_{LO-}	$V_{LO}=V_{CC}=15V$	—	2.0	—	A

PACKAGE INFORMATION

32 PINS, LQFP, 7X7 MM

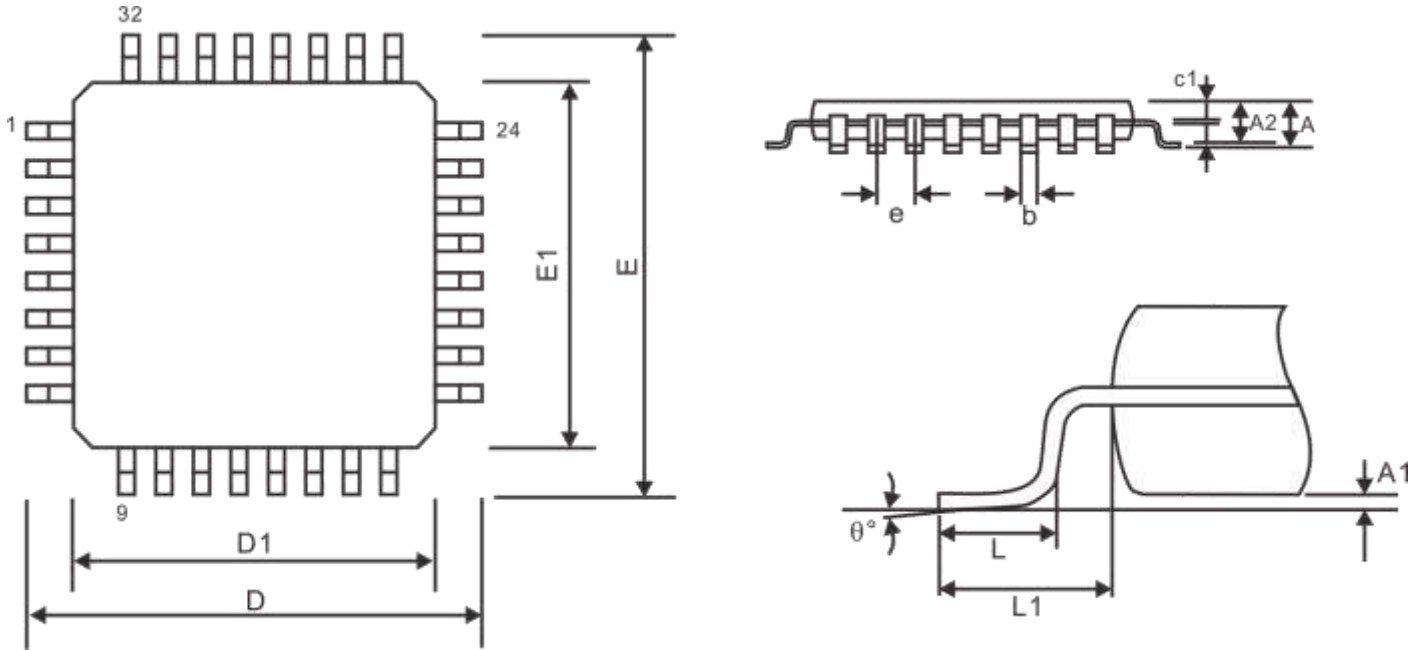

Symbol	Dimensions(mm)		
	Min.	Nom.	Max.
A	-	-	1.60
A1	0.05	-	0.15
A2	1.35	1.40	1.45
b	0.30	0.37	0.45
c1	0.09	-	0.20
D	9.00 BSC.		
D1	7.00 BSC.		
E	9.00 BSC.		
E1	7.00 BSC.		
e	0.80 BSC.		
L	0.45	0.60	0.75
L1	1.00 REF.		
θ	0°	3.5°	7°

Notes: Refer to JEDEC MS-026 BBA

32 Pins, QFN, 5X5 MM

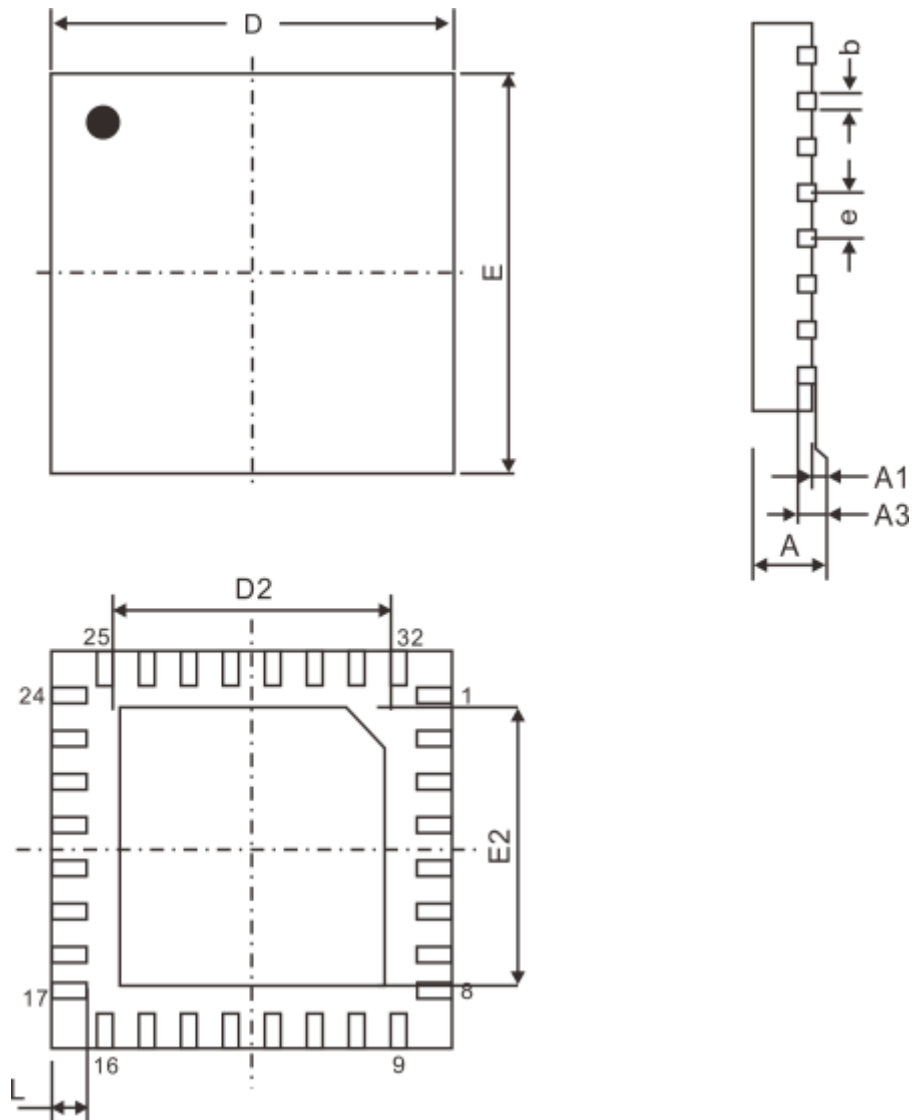

Symbol	Dimensions(mm)		
	Min.	Nom.	Max.
A	0.70	0.75	0.80
A1	0.00	0.02	0.05
A3	0.20 REF		
b	0.18	0.25	0.30
D	5.00 BSC		
D2	3.15	-	3.30
E	5.00BSC		
E2	3.15	-	3.30
e	0.50 BSC.		
L	0.35	0.40	0.45

Notes: Refer to JEDEC MO-220 WHHD-5

IMPORTANT NOTICE

Princeton Technology Corporation (PTC) reserves the right to make corrections, modifications, enhancements, improvements, and other changes to its products and to discontinue any product without notice at any time.

PTC cannot assume responsibility for use of any circuitry other than circuitry entirely embodied in a PTC product. No circuit patent licenses are implied.

Princeton Technology Corp.
2F, No. 233-1, Baociao Road,
Sindian Dist., New Taipei City 23145, Taiwan
Tel : 886-2-66296288
Fax: 886-2-29174598
<http://www.princeton.com.tw/>

X-ON Electronics

Largest Supplier of Electrical and Electronic Components

Click to view similar products for [Motor/Motion/Ignition Controllers & Drivers](#) category:

Click to view products by [Princeton](#) manufacturer:

Other Similar products are found below :

[FSB50550TB2](#) [MSVCPM2-63-12](#) [MSVGW45-14-2](#) [MSVGW54-14-3](#) [NTE7043](#) [LA6565VR-TLM-E](#) [LB1837M-TLM-E](#) [STK534U342C-E](#)
[AM4967GSTR-G1](#) [TB6562AFG\(O,8,EL\)](#) [BA5839FP-E2](#) [VND5T050AK-E](#) [LA6584JA-AH](#) [LB11961-W-AH](#) [LC898212XD-SH](#)
[NCV70501DW002R2G](#) [TND315S-TL-2H](#) [FSB50250AB](#) [FNA41060](#) [MSVBTC50E](#) [MSVCPM3-54-12](#) [MSVCPM3-63-12](#) [MSVCPM4-63-12](#)
[FSB50550AB](#) [L99MC6TR](#) [LC898301XA-MH](#) [LV8413GP-TE-L-E](#) [MSVGW45-14-3](#) [MSVGW54-14-4](#) [TB6552FNG,C,8,EL](#) [LB11651-E](#)
[IRSM515-025DA4](#) [LV8127T-TLM-H](#) [MC33812EKR2](#) [MC33PT2000AF](#) [LB11851FA-BH](#) [LB1938FAGEVB](#) [TB6569FTG,8,EL](#)
[STIPN2M50-H](#) [BH67172NUX-GE2](#) [RSHR4006BV20](#) [DMPU-CPAN](#) [DMPU-CPC](#) [DMPUC-R2](#) [AIS-D-42MA](#) [FNB81560T3](#)
[NCV7535DBR2G](#) [NCP81274MNTXG](#) [PT8A2767FWEX](#) [IM240S6Y1BAKMA1](#)