

Description

The P1405 over-voltage protection device features an ultra-low 30mΩ (typical) on-resistance high current integrated N-MOSFET which actively protects low-voltage systems from voltage supply faults up to +30VDC. An input voltage exceeding the over-voltage threshold will cause the internal MOSFET to turn off, preventing excessive voltage from damaging downstream devices. P1405 has thermal protection at 140°C

The P1405 is available in a RoHS and Green compliant DFN2x2-6L package.

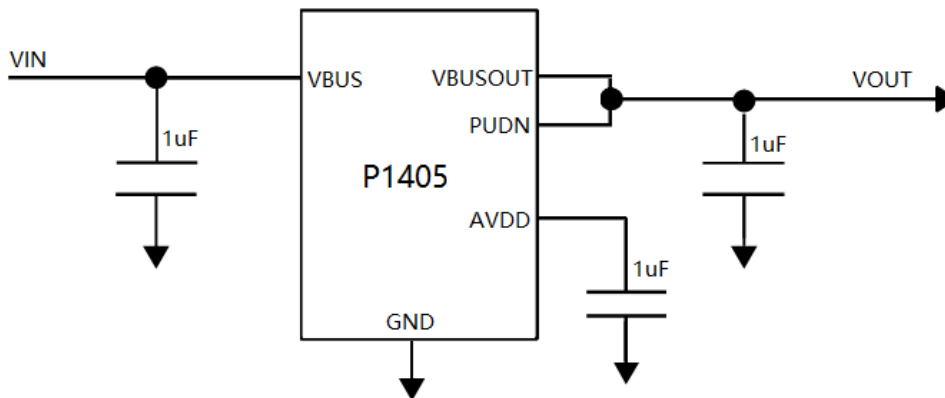

Figure 1: Typical Application

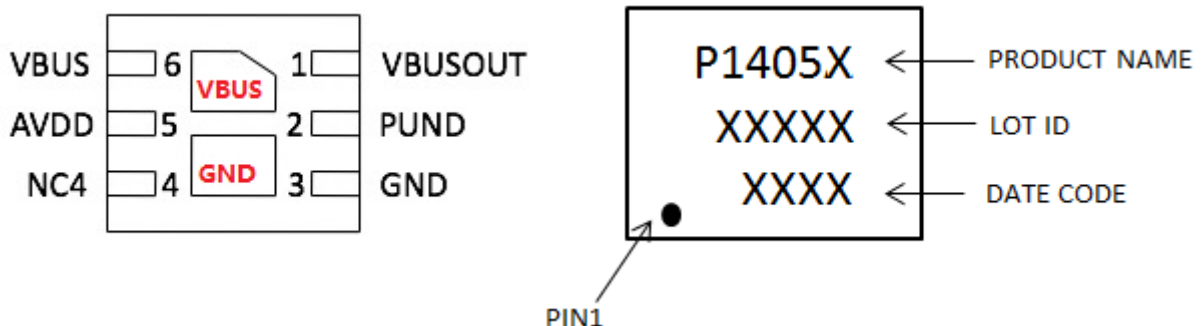

Figure 2: Pin order (Bottom view) and Marking (Top view)

Feature

- Wide Input voltage range: 3.0-30v
- Ultra-low 30mohm On-resistance.
- Fixed OVPTThreshold
 - P1405A : 6.0V
 - P1405B : 10.6V
 - P1405C : 13.8V
 - P1405D : 5.5V
- Fast turn-off response time: 50ns
- Soft-start function to avoid in-rush current
- -40-85°C operation temperature

Application

- Cellular Phones, Smart Phones, PDAs
- Tablet, Portable Media Players
- Gaming Device, Digital Cameras

Pin Definitions

Pin#	Name	Description
1	VBUSOUT	Output voltage;
2	PUND	Pull down output voltage to ground when input voltage is higher than 6.0v;
4	NC4	Not connected;
3	GND	Ground;
5	AVDD	Internal regulator voltage, connect 1uF capacitor to GND;
6	VBUS	Input voltage;

Block Diagram

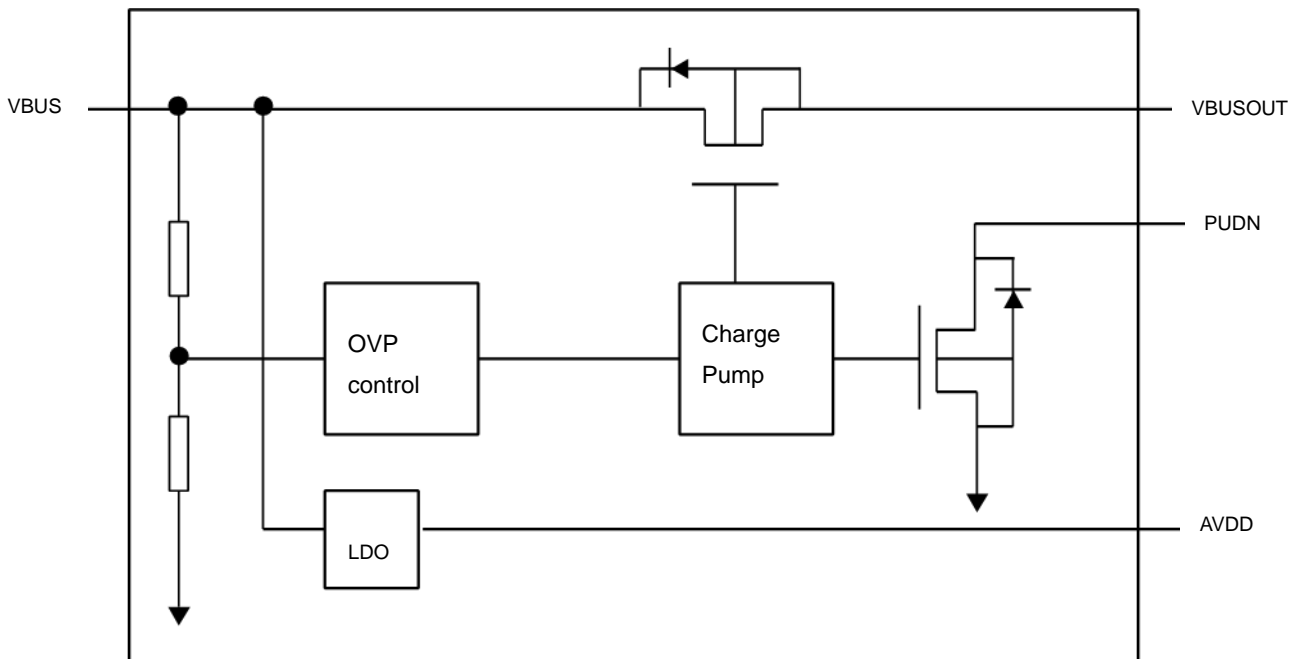

Figure 3: IC Block Diagram

Absolute maximum rating

Parameter(Note1)	Symbol	Value	Units
VBUS voltage range	V_{BUS}	-0.3 to 30	V
VBUSOUT voltage range	V_{BUSOUT}	-0.3 to 16	V
PUDN voltage range	V_{PUDN}	-0.3 to 16	V
AVDD voltage range	V_{AVDD}	-0.3 to 7	V
Switch I/O Continuous Current	I_{IN}	3	A
Junction temperature	T_J	150	°C
Lead temperature(Soldering,10s)	T_L	260	°C
Storage temperature	T_{STG}	-55 to 150	°C
ESD Ratings	HBM (Except VBUSOUT PIN)	3000	V
	CDM	1000	V

Note 1: Stresses greater than those listed under "Absolute Maximum Ratings" may cause permanent damage to the device. These are stress ratings only, and functional operation of the device at these or any other conditions beyond those indicated under "Recommended Operating Conditions" is not implied. Exposure to "Absolute Maximum Ratings" for extended periods may affect device reliability.

Recommended Operating Conditions

Parameter	Symbol	Value	Units
VBUS input voltage range	V_{BUS}	3.0 to 30, typical=5	V
Operating ambient temperature	T_A	-40 to 85	°C
Thermal Resistance	$R_{\theta JA}$	67.5	°C/W

Note 2: Junction to Ambient thermal resistance is highly dependent on PCB layout. Values are based on thermal properties of the device when soldered to an EV board.

Electrical Characteristics

($T_A=25^{\circ}\text{C}$, $V_{BUS}=5\text{V}$, $C_{IN}=1\mu\text{F}$, $C_{OUT}=1\mu\text{F}$, for 5V application, unless otherwise specified.)

Parameter	Symbol	Conditions	Min.	Typ.	Max.	Units
Basic Operation						
Quiescent Supply Current	I_{DDQ1}	$V_{BUS}=5\text{V}$, No load		0.4		mA
	I_{DDQ2}	$V_{BUS}=30\text{V}$, No load		1.2	2	mA
UVLO Threshold Voltage	V_{UVLO}	V_{BUS} Rising		2.4	3.2	V
Start-up Delay Time	T_{START_DLY}	$V_{BUS}=0 \rightarrow 5\text{V}$ to Output ON		0.5		ms
Main Switch ON-Resistance	R_{ON}	$V_{BUS}=5\text{V}$, $I_{OUT}=1\text{A}$		30	40	m Ω
Over-Voltage Protection						
VBUS OVP Threshold	V_{OVP}	V_{BUS} Rising (P1405A)	5.85	6.0	6.15	V
		V_{BUS} Rising (P1405B)	10.4	10.6	10.8	
		V_{BUS} Rising (P1405C)	13.5	13.8	14.1	
		V_{BUS} Rising (P1405D)	5.35	5.5	5.65	
OVP Response Time	t_{OVP}	$V_{IN} > V_{OVP}$ to V_{OUT} stop rising		50		nS
OVP Recovery Time	t_{R_OVP}	$V_{IN} < V_{OVP}$ to V_{OUT} start rising		0.5		ms
Output discharge resistance	R_{DCHG}	$V_{IN} > V_{OVP}$		120		Ω
Thermal Protection						
Over-Temperature Protection Threshold	T_{SD}			140		$^{\circ}\text{C}$
Over-Temperature Protection Hysteresis	T_{HYS}			20		$^{\circ}\text{C}$

Typical Characteristics



Fig 1. Start-up waveform

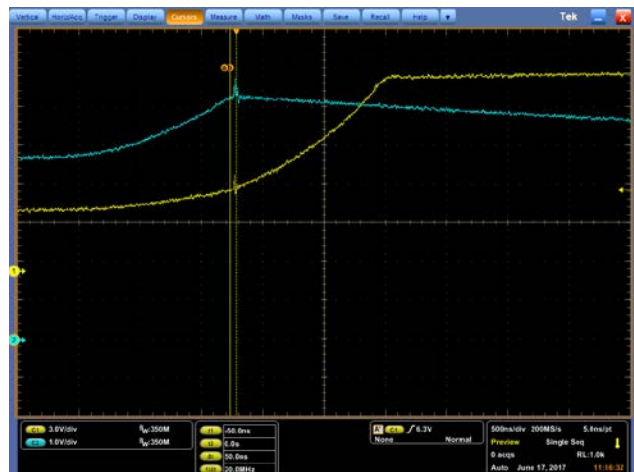

Fig2. OVP response



Fig3. OVP recovery waveform (OVP 6V)

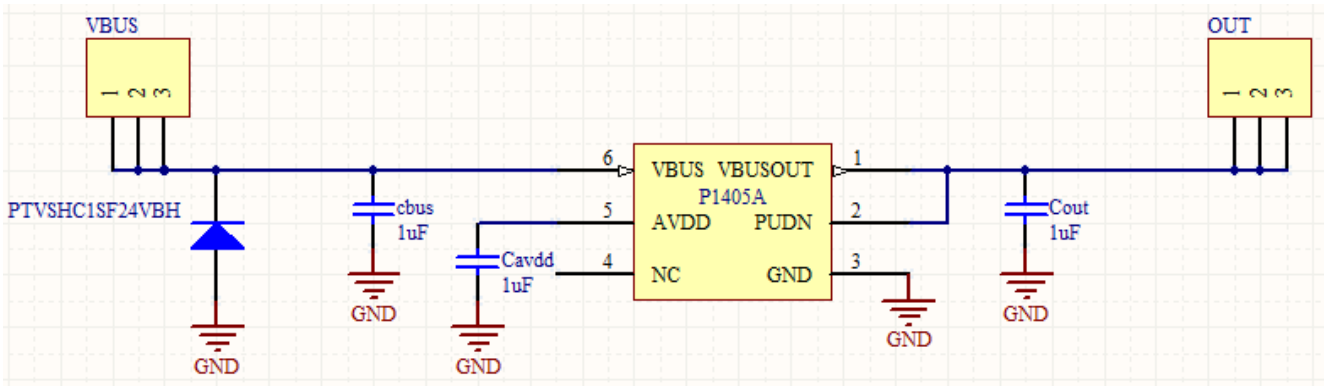

Fig4. OVP test schematic

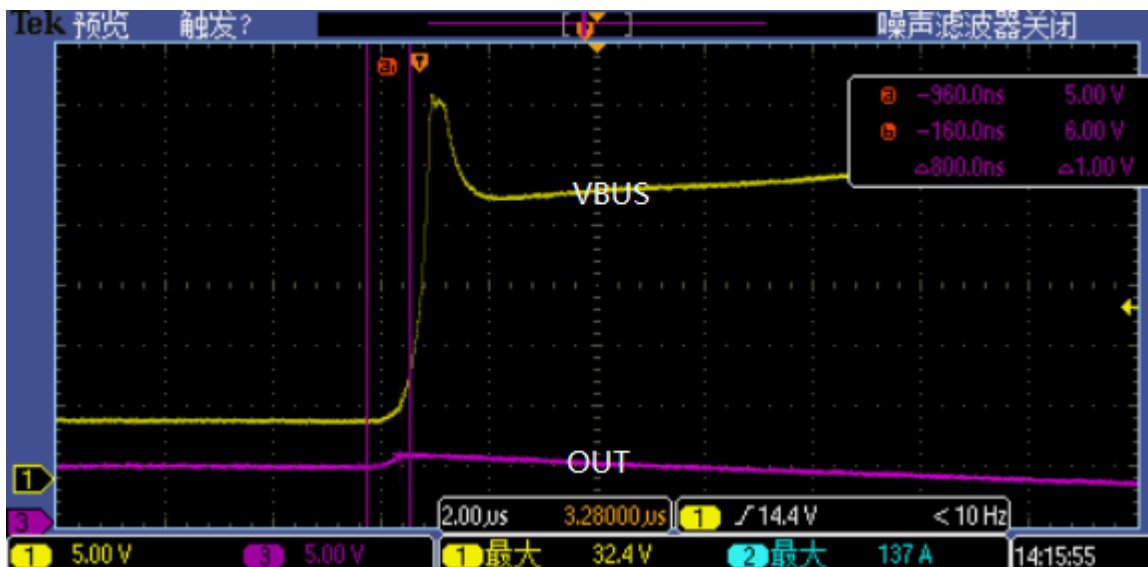
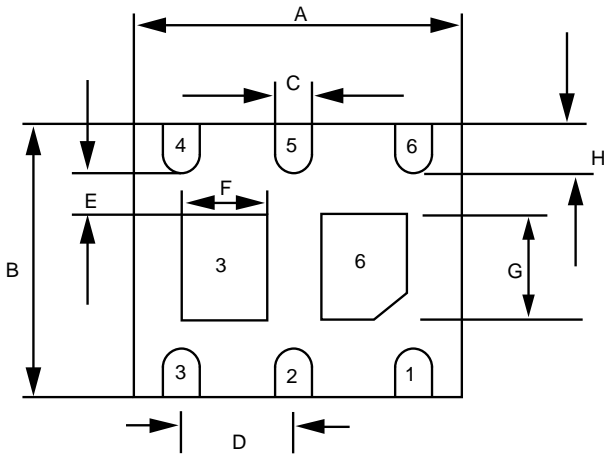
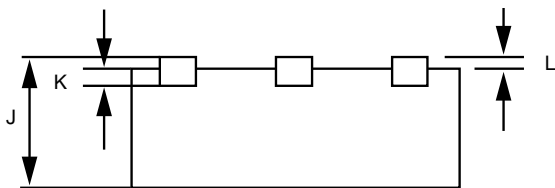
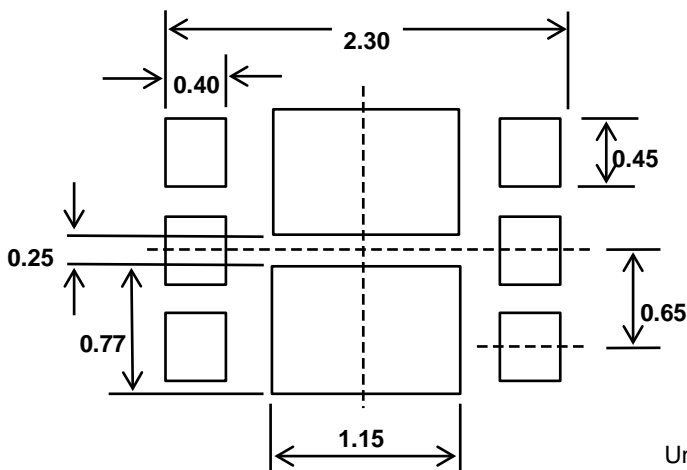

Fig5. 8-20 Surge test (Base on Schematic, Fig 4.)

Product dimension (DFN2x2-6L)

Bottom view

Side view

Dim	Millimeters		Inches	
	MIN	MAX	MIN	MAX
A	1.924	2.076	0.076	0.082
B	1.924	2.076	0.076	0.082
C	0.250	0.400	0.010	0.016
D	0.650 (typ.)		0.026 (typ.)	
E	0.200 MIN.		0.008 MIN.	
F	0.520	0.720	0.020	0.028
G	0.750	1.100	0.030	0.043
H	0.174	0.380	0.007	0.015
J	0.550	0.800	0.022	0.031
L	0	0.050	0	0.002
K	0.180	0.200	0.007	0.008



Unit:mm

PCB Layout Guide

IMPORTANT NOTICE

 and **Prisemi**[®] are registered trademarks of **Prisemi Electronics Co., Ltd (Prisemi)** ,Prisemi reserves the right to make changes without further notice to any products herein. Prisemi makes no warranty, representation or guarantee regarding the suitability of its products for any particular purpose, nor does Prisemi assume any liability arising out of the application or use of any product or circuit, and specifically disclaims any and all liability, including without limitation special, consequential or incidental damages. “Typical” parameters which may be provided in Prisemi data sheets and/or specifications can and do vary in different applications and actual performance may vary over time. All operating parameters, including “Typicals” must be validated for each customer application by customer’s technical experts. Prisemi does not convey any license under its patent rights nor the rights of others. The products listed in this document are designed to be used with ordinary electronic equipment or devices, Should you intend to use these products with equipment or devices which require an extremely high level of reliability and the malfunction of with would directly endanger human life (such as medical instruments, aerospace machinery, nuclear-reactor controllers, fuel controllers and other safety devices), please be sure to consult with our sales representative in advance.

Website: <http://www.prisemi.com>

For additional information, please contact your local Sales Representative.

©Copyright 2009, Prisemi Electronics

 **Prisemi**[®] is a registered trademark of Prisemi Electronics.

All rights are reserved.

X-ON Electronics

Largest Supplier of Electrical and Electronic Components

Click to view similar products for [Battery Management](#) category:

Click to view products by [Prisemi](#) manufacturer:

Other Similar products are found below :

[MP2602DQ-LF-P](#) [MP26053DQ-LF-Z](#) [MP2611GL-P](#) [NCP347MTAHTBG](#) [LM3658SD-AEV/NOPB](#) [MP2607DL-LF-P](#) [MP26121DQ-LF-P](#)
[MP26123DR-LF-P](#) [MP2633GR-P](#) [MP2637GR-P](#) [BQ24212EVM-678](#) [NCP1855FCCT1G](#) [MP2636GR-P](#) [FAN54063UCX](#)
[MAX14680EWC+T](#) [MAX14634EWC+T](#) [DS2745U+T&R](#) [MAX14578EETE+T](#) [DS2781EVKIT+](#) [DS2781E+T&R](#) [MP2605DQ-LF-P](#)
[DS2710G+T&R](#) [MAX17040G+T](#) [MAX14525ETA+T](#) [MP2615GQ-P](#) [MAX14578EEWC+T](#) [LC05132C01NMTTGTG](#) [MAX8971EWP+T](#)
[MAX14630EZK+T](#) [MAX1873TEEE+T](#) [PSC5415A](#) [AUR9811DGD](#) [SN2040DSQR](#) [DS2715BZ+T&R](#) [MAX1508ZETA+T](#)
[MAX14921ECS+T](#) [MAX77301EWA+T](#) [BD8668GW-E2](#) [MAX16024PTBS+T](#) [DS2715Z+T&R](#) [MAX16024LTBZ18+T](#) [DS2782E+T&R](#)
[DS2782G+T&R](#) [MAX1908ETI+T](#) [ISL95522IRZ](#) [ISL95522HRZ](#) [ARD00558](#) [NCP4371AAEDR2G](#) [BD8665GW-E2](#) [MAX8934EETI+T](#)