

產品編碼 P/N	PSCLAQ0905 Series	測試設備 TEST INSTRUMENT	Keysight:E4991B Chroma:16502 3302
產品系列 Series	共模线性滤波器	測試頻率 TEST FREQUENCY	参考规格书内定义

客戶名稱  
Customer

客戶編碼  
Customer P/N

產品系列  
Series

共模线性滤波器  
Common Mode Linear Filter

產品編碼  
Supply P/N

PSCLAQ0905 Series

發版號  
Version

A2.3

承認日期  
Endorsement Date

2022-9-16

備註  
Note

譜羅德電子科技（深圳）有限公司 PuLuoDe Electronic Technology (Shenzhen) Co. LTD	
製作 APPROVED	Ben
審查 CHECKED	Yuki
確認 PREPARED	Peter

客戶承認

Customer Approval

客戶簽章

A2.3

## 修訂記錄

### REVISION RECORD



產品編碼 P/N	PSCLAQ0905 Series	測試設備 TEST INSTRUMENT	Keysight:E4991B Chroma:16502 3302
產品系列 Series	共模线性滤波器	測試頻率 TEST FREQUENCY	参考规格书内定义

Version	REVISION ITEM	BEFORE REVISION	AFTER REVISION	DATE
A2.3				2022-9-16

Page 2 / 9



譜羅德電子科技（深圳）有限公司  
PuLuoDe Electronic Technology (Shenzhen) Co., LTD

深圳市寶安區石岩三聯工業區B棟311

更多规格请访问谱罗德官方网站  
下载或者扫描二维码通过微信小程序  
获取

<http://www.prodtech.cn/>



產品編碼 P/N	PSCLAQ0905 Series	測試設備 TEST INSTRUMENT	Keysight:E4991B Chroma:16502 3302
產品系列 Series	共模线性滤波器	測試頻率 TEST FREQUENCY	参考规格书内定义

封装尺寸  
Dimension (mm)

推荐的焊盘尺寸  
Recommaned Land Pattern

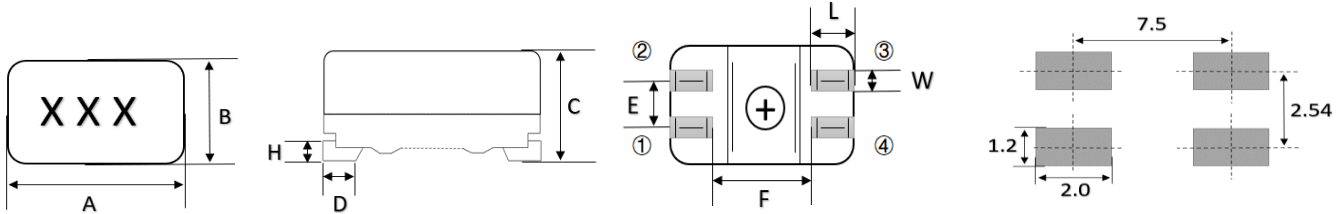

系列 Series	封装尺寸 Dimension								
	A	B	C	D	H	E	F	L	W
0905	9.2±0.3	6.0±0.3	5.0±0.3	1.4 Max	0.8±0.2	2.54 Ref	5.7 Ref	1.8 Max	1.0 Ref

編碼解釋

Code interpretation

<b>PSCLAQ</b>	<b>0905</b>	<b>102</b>	<b>Y</b>
類別碼	尺寸系列	阻抗值	精度
Category code	Dimension	Impedance	Tolerance

電氣參數

Electrical Characteristics

產品編碼 P/N	@ 25 °C Ambient Temperature							
	感值值 (L)	精度 Tolerance	測試頻率 Test Frequency	DCR	額定電流 Rated Current	滤波范围 Frequency Range	額定電壓 Rated Voltage	阻抗 Impedance
	N1=N2 μH	±	KHZ	Ω Max	mA ΔT≈40°C	MHZ(Ref.)	V	Ω@10MHZ Min
PSCLAQ0905-100N	10	30%	1KHZ/ 0.1V	0.08	1600	20~200	80	200
PSCLAQ0905-250N	25	30%		0.16	1000	5~100	80	600
PSCLAQ0905-400N	40	30%		0.25	900	5~100	80	800
PSCLAQ0905-500N	50	30%		0.32	800	5~50	80	1500
PSCLAQ0905-251Y	250	50%	100KHZ /5mV	0.13	1200	5~50	80	600
PSCLAQ0905-471Y	470	50%		0.14	1100	1~50	80	1000
PSCLAQ0905-501Y	500	50%		0.15	1000	1~40	80	1000
PSCLAQ0905-102Y	1000	50%		0.31	800	1~30	80	1500
PSCLAQ0905-202Y	2000	50%		0.42	600	1~10	80	3000
PSCLAQ0905-472Y	4700	50%		0.9	400	0.5~5	80	4000
PSCLAQ0905-652Y	6500	50%		1.05	300	0.3~2	80	5000

- ◎ 規格參數基於環境溫度25°C取得  
All test Data is referenced to 25°C ambient
- ◎ 電感工作環境溫度：-40°C ~ 105°C  
Operating temperature range -40 °C to +105 °C
- ◎ 加載額定電流會使電感溫度上升大約 40°C (電感初始溫度+上升溫度=電感最終溫度)  
Typical Heat Rating DC Current would cause an approximately ΔT of 40°C
- ◎ 務必考慮最終的產品設計，元器件佈局，線路板走線，以及使用環境過程中，電感最終溫度不得超過105°C  
The operating temperature of inductance do not exceed 105°C
- ◎ 使用電感時，請查閱第8注意事項  
The announcements is on page 9

Page 3 / 9



產品編碼 P/N	PSCLAQ0905 Series	測試設備 TEST INSTRUMENT	Keysight:E4991B Chroma:16502 3302
產品系列 Series	共模线性滤波器	測試頻率 TEST FREQUENCY	参考规格书内定义

特性曲線

Performance Curves

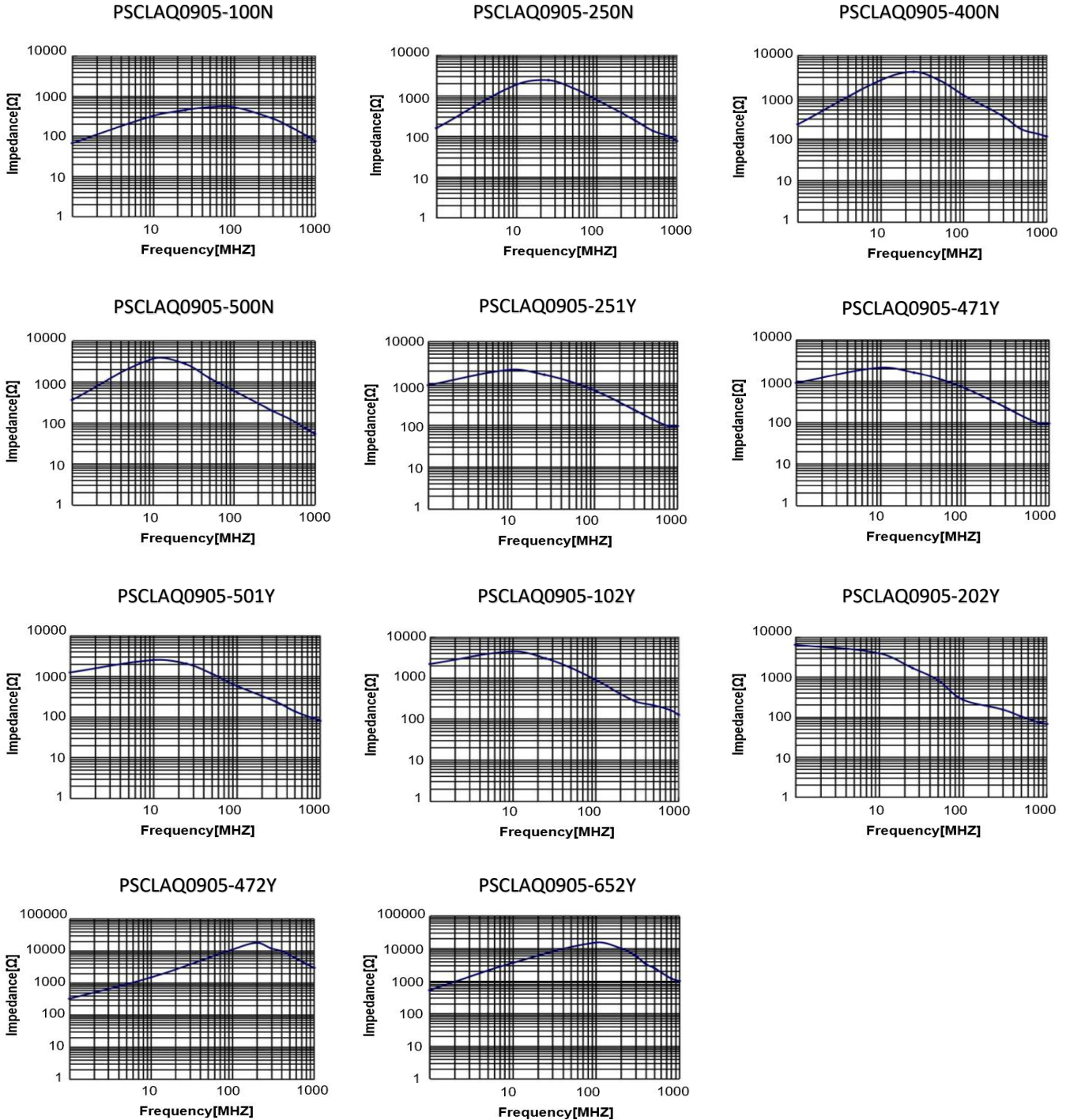



產品編碼 P/N	PSCLAQ0905 Series	測試設備 TEST INSTRUMENT	Keysight:E4991B Chroma:16502 3302
產品系列 Series	共模线性滤波器	測試頻率 TEST FREQUENCY	参考规格书内定义

電路結構  
Connections

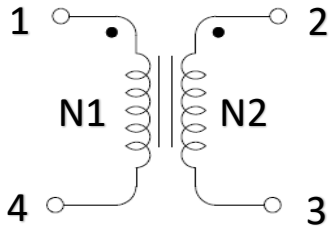

◎ 電感內置兩組線圈  
Inductor Contents Two (2) Set(s) of Coil

◎ 电感顶部使用激光蚀刻印字  
Laser printing is used at the top of the inductor

內部構造  
Internal Structure

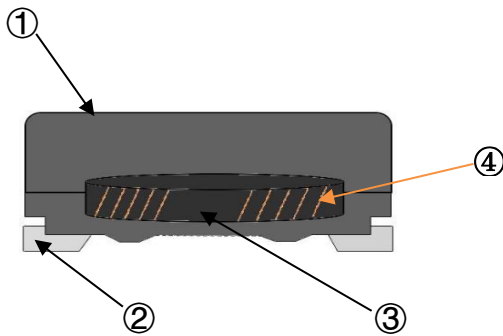

- ①：罩子 / Cover
- ②：電極 / Electrode
- ③：磁芯 / Core
- ④：線圈 / Coil

焊接溫度（推荐）  
Recommended Soldering Temperature Graph

TEMPERATURE (°C)

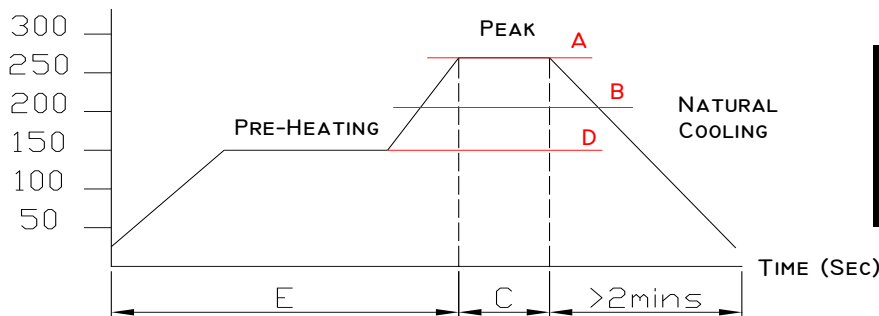

A	260°C
B	230°C
C	10 Sec
D	150°C
E	60~240 Sec



產品編碼 P/N	PSCLAQ0905 Series	測試設備 TEST INSTRUMENT	Keysight:E4991B Chroma:16502 3302
產品系列 Series	共模线性滤波器	測試頻率 TEST FREQUENCY	参考规格书内定义

## 机械可靠性测试

## Mechanical Reliability

實驗名稱 ITEM	試驗要求 Specification & Requirement	試驗方法 Method Used
可焊性實驗 Solderability	The surface of terminal/pin tested shall be covered with new solder by 95%	Solder heat proof: Preheating: 180 ±10°C 90 seconds Soldering: 255 ±5°C for 3 ±1 sec
機械衝擊 Shock	Inductance change within ± 5% Without mechanical damage	Drop down with 981m/s <sup>2</sup> (100G) shock Attitude upon a rubber block method shock testing machinem, 3 tests.
振動實驗 Vibration	Inductance change within ± 5% Without mechanical damage	Vibration frequency: 10Hz to 55Hz to 10Hz 60 seconds cycle Vibration time: 2 hours

## 老化测试

## Aging Reliability

實驗名稱 ITEM	試驗要求 Specification & Requirement	試驗方法 Method Used
冷熱衝擊 Thermal Shock	Inductance change within ± 5% Without mechanical damage	-25°C, (30 mins) -> room temp. (5 mins) -> 105°C, (30 mins) -> room temp. (5 mins) 100 cycles
耐熱性 Heat Resistance	Inductance change within ± 5% Without mechanical damage	Apply IDC current @ 85°C ambient Duration: 500 hrs
耐濕性 Humidity Resistance	Inductance change within ± 5% Without mechanical damage	Apply IDC current @ 60°C ambient Humidity: 90~95% Duration: 500 hrs
低溫存儲實驗 Low Temp. Storing	Inductance change within ± 5% Without mechanical damage	Storing Temp. -25 ±2 °C for total 500 +4/-0 hours
高溫存儲實驗 High Temp. Storing	Inductance change within ± 5% Without mechanical damage	Storing Temp. 105 ±2 °C for total 500 +4/-0 hours



# 包裝方式

## PACKING FOR SMD



產品編碼 P/N	PSCLAQ0905 Series	測試設備 TEST INSTRUMENT	Keysight:E4991B Chroma:16502 3302
產品系列 Series	共模线性滤波器	測試頻率 TEST FREQUENCY	参考规格书内定义

載帶卷盤尺寸 : (mm)

**Packing Dimension**

MPQ	A	B	C	D	P	P1	W	L
1000pcs/卷盤	330 Typ	21 Ref	13 Ref	18 Ref	12 Ref	4 Ref	12 Ref	前后预留约30空格

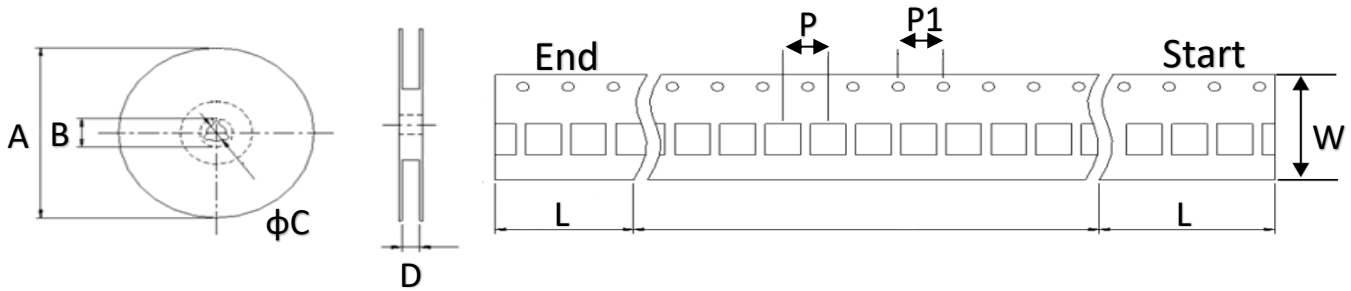

**載帶內產品排列方式:**

Inductance Packing Method

首字对孔

The first mark is on the side of the gear hole

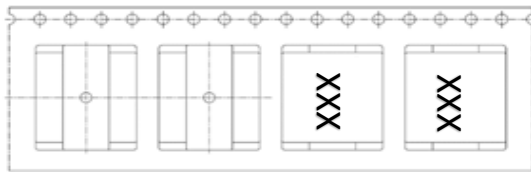

**載帶剝離力:**

Typical Pulling Force

20~120 gf

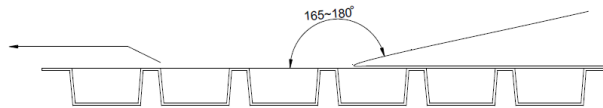

**裝箱數量:**

Package Quantity

1000pcs/卷盤  
1000pcs/Reel

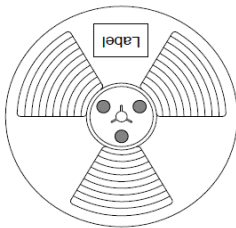

3000pcs/每盒  
3000pcs/ Middle box

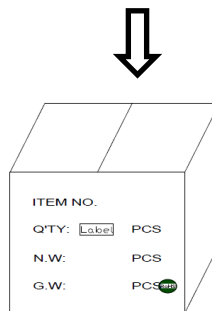
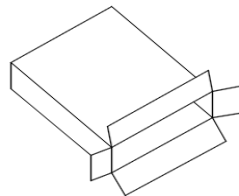

12000pcs/每箱  
12000pcs/ Outer box

© 實際出貨過程，依據客戶需求狀況的不同，包裝數量會有變化，最終的包裝數量請參照實際出貨包裝

In the actual delivery process, the package quantity will change according to the different customer demands. Please refer to the actual shipment quantity for the final package quantity





## 注意事項

使用本產品時，請注意以下事項

- ◎ 產品保存期限為12個月，保存條件：溫度5~40℃，濕度10~75%RH以內，超過保存期限可能會使產品端子電極發生氧化。
- ◎ 請勿在極端環境下使用和保存（高鹽，強酸，強鹼，強輻射等）。
- ◎ 產品焊接前，請進行預熱；預熱溫度與焊接溫度之間溫差建議控制在150℃以內。
- ◎ 產品焊接後需重新拆卸焊接修正時，請遵循規格書規定的條件範圍；過高的加熱溫度以及反復的拆卸可能會導致產品失效。
- ◎ 產品請勿接觸清洗劑，酒精等液體，這會侵蝕產品本體，從而導致產品失效。
- ◎ 產品焊接到線路板後，請注意不可因線路板整體變形或局部變形而施加給電感剩餘應力，這可能會導致電感發生破裂，脫落，以致失效。
- ◎ 產品通電後溫度會隨電流的增大而上升，設計時請務必考慮留有餘量。
- ◎ 過高的靜電會對產品產生永久性損害，請注意靜電防護。
- ◎ 產品通電過程請勿觸摸產品任何部位，防止觸電。
- ◎ 本產品作為磁性產品，設計時請務必考慮周邊元器件與本產品可能產生的相互影響。
- ◎ 本產品適用於一般電子設備，如：AV設備，通信設備，家電產品，娛樂設備，電腦設備，個人設備，辦公設備，計測設備，工業機器人等。且該一般電子設備需在常規的操作和使用方法環境下使用。對於需要高度安全性和可靠性的，或者因本產品失效造成設備故障，誤操作，運轉不良等危及到人的生命身體及財產安全，以及對社會產生較大不良影響的特殊用途，設計使用前務必同本公司溝通，設計使用者如在未取得我司書面同意狀況下使用造成任何後果，我司不予承擔。特殊用途包含但不限定如下清單：
  - 1 軍用設備
  - 2 運輸設備（汽車，軌道交通產品，船舶等）
  - 3 航空，航太設備
  - 4 發電控制設備
  - 5 核動力相關設備
  - 6 爆炸引燃控制設備
  - 7 交通控制設備
  - 8 關係到國防安全的設備
  - 9 其他被認定為特殊用途的設備







## ANNOUNCEMENTS

Please read this before using the product.

- © The product storage life is 12 months, Storage Temperature: TEMP.5~40°C; RH10%~75%. Please use the product within the warranty period
- © Do not use or store in locations where there are conditions such as gas corrosion (salt, acid, alkali, radiation etc.) .
- © Before soldering, be sure to preheat components:The preheating temperature should be set so that The temperature difference between the solder temperature and chip temperature does not exceed 150° C.
- © Soldering corrections after mounting should be within the range of the conditions determined in the specifications. If overheated, a short circuit, performance deterioration, or lifespan shortening may occur. Repeated disassembly may invalidate the inductance
- © The cleaning agent can not be used for these products. This may corrode the inductor
- © When embedding a printed circuit board where a chip is mounted to a set, be sure that residual stress is not given to the chip due to the overall distortion of the printed circuit board and partial distortion such as at screw tightening portions.
- © Self heating (Rated Current or Irms) occurs when the power is turned ON, so the tolerance should be sufficient for the set thermal design.
- © Too high static electricity will cause permanent damage to the product, please pay attention to electrostatic protection.
- © As a magnetic product, the design must consider the possible interaction between peripheral components and the product.
- © The products listed on this catalog are intended for use in general electronic equipment (AV equipment, telecommunications equipment, home appliances, amusement equipment, computer equipment, personal equipment, office equipment, measurement equipment, industrial robots) under a normal operation and use condition.  
The products are not designed or warranted to meet the requirements of the applications listed below, whose performance and/or quality require a more stringent level of safety or reliability, or whose failure, malfunction or trouble could cause serious damage to society, person or property.  
If you intend to use the products in the applications listed below or if you have special requirements exceeding the range or conditions set forth in the each catalog, please contact PROD. Otherwise, PROD will not bear the serious consequences caused by product quality problems

- |  |   |
|--|---|
| 1 Military equipment                                   | 8 Medical equipment   |
| 2 Transportation equipment (cars, trains, ships, etc.) | 9 Other applications that are not considered general-purpose applications |
| 3 Aerospace/aviation equipment                         |   |
| 4 Power-generation control equipment                   |   |
| 5 Atomic energy-related equipment                      |   |
| 6 Explosive ignition control equipment                 |   |
| 7 Transportation control equipment                     |   |



## X-ON Electronics

Largest Supplier of Electrical and Electronic Components

*Click to view similar products for [Common Mode Chokes / Filters](#) category:*

*Click to view products by [PROD Technology](#) manufacturer:*

Other Similar products are found below :

[PE-64683](#) [RD5122-6-9M6](#) [ST6118T-R](#) [FE3X025-10-7NL](#) [T8114NLT](#) [TCM0806G-350-2P-T](#) [TCM0806G-650-2P-T](#) [IND-0110](#)  
[UAL21VR0802000](#) [UALSC023000000](#) [UALSC1020JH000](#) [UALSU10VD20010](#) [UALSU9VD070100](#) [36-00037](#) [CM7060M132R-10](#)  
[UALW21HS072450](#) [UALSU9H0208000](#) [UAL24VK06450CH](#) [PLT10HH501100PNB](#) [PLT10HH401100PNB](#) [PLT10HH1026R0PNB](#) [36-](#)  
[00029-01](#) [PE-67531](#) [TLH10UB](#) [113 OR5](#) [2752045447](#) [CM8663Z161B-10](#) [7351V](#) [CMF16-153131](#) [T8116NLT](#) [CMS2-10-R](#) [FE2X10-4-2NL](#)  
[T8003NLT](#) [CTX01-13663](#) [CTX66-19521-R](#) [RC212-0.5-10M](#) [RC112-0.4-15M](#) [RC212-0.6-6M8](#) [RC212-0.4-15M](#) [RC112-0.3-30M](#) [4534-3](#)  
[WTCF2012Z0M751PB](#) [PH9408.814NLT](#) [B82498B3221J000](#) [PAC6006.364NLT](#) [PAC6006.444NLT](#) [PAC6006.204NLT](#) [PH9407.204NLT](#)  
[PAC6006.264NLT](#) [PH9408.105NLT](#) [PH9408.494NLT](#)