

ITEM P/N	PSPMAF0615-R22M-CGF-AP	TEST INSTRUMENT	Zentech-3305 / Zentech502BC
PRODUCT	SMD Inductor	TEST FREQUENCY	100 kHz / 1.0V

CUSTOMER :**CUSTOMER P/N :****DESCRIPTION :** SMD INDUCTOR**P/N :** PSPMAF0615-R22M-CGF-AP**REVISION NO. :** Version: 1.0**DATE :** 2016-1-13**NOTES :** STANDARD

DOCUMENTED	
APPROVED	Kevin
CHECKED	Ben
PREPARED	Peter

CUSTOMER APPROVAL

company seals

ITEM P/N	PSPMAF0615-R22M-CGF-AP	TEST INSTRUMENT	Zentech-3305 / Zentech502BC
PRODUCT	SMD Inductor	TEST FREQUENCY	100 kHz / 1.0V

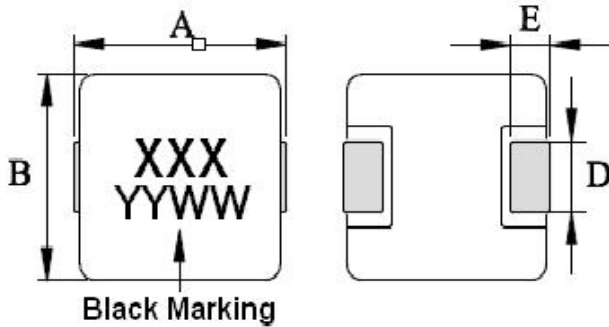
PACKING DIMENSIONS (mm)

0615	Dimensions
A	7.0±0.5
B	6.6±0.3
C	1.3 ± 0.2
D	3.0±0.3
E	1.8±0.5

EXPLANATION OF PART NUMBERS

P	S	P	M	A	F	0	6	1	5	-	R	2	2	M	-	C	G	F	-	A	P
<u>Serial Codes</u>						<u>Size</u>					<u>Inductance</u>				<u>Description</u>						

ELECTRICAL CHARACTERISTICS

ITEM P/N	@ 26 °C Ambient Temperature				DCR mΩ @ 25°C MAX
	INDUCTANCE		Typical Heat Rating DC Current (A) (Idc)	Typical Saturation DC Current (A) (Isat)	
	Lo (μH)	TOLERANCE			
PSPMAF061 5-R22M- CGF-AP	0.22	±20%	14	22	5.2

- ⊙ All test Data is referenced to 25°C ambient
- ⊙ Typical Heat Rating DC Current would cause an approximately ΔT of 40°C
- ⊙ Typical Saturation DC Current would cause Lo to drop approximately 20%
- ⊙ Operation Temperature Range : -55°C ~ 125°C
- ⊙ The Part temperature (ambient + ΔT) should not exceed 125°C under worst case operating conditions.
- ⊙ Circuit design, component placement, PWB trace size and thickness, airflow and other cooling provisions

all effect the part temperature. Part temperature should be verified in the end application.

Page: 1

ITEM P/N	PSPMAF0615-R22M-CGF-AP	TEST INSTRUMENT	Zentech-3305 / Zentech502BC
PRODUCT	SMD Inductor	TEST FREQUENCY	100 kHz / 1.0V

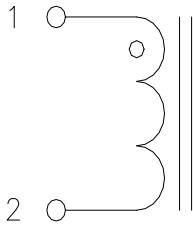
CONNECTIONS

- ⊙ Inductor Contents ONE (1) Set(s) of Coil
- ⊙ DC/AC Current Shall Be Introduced By Any One of Two Pads

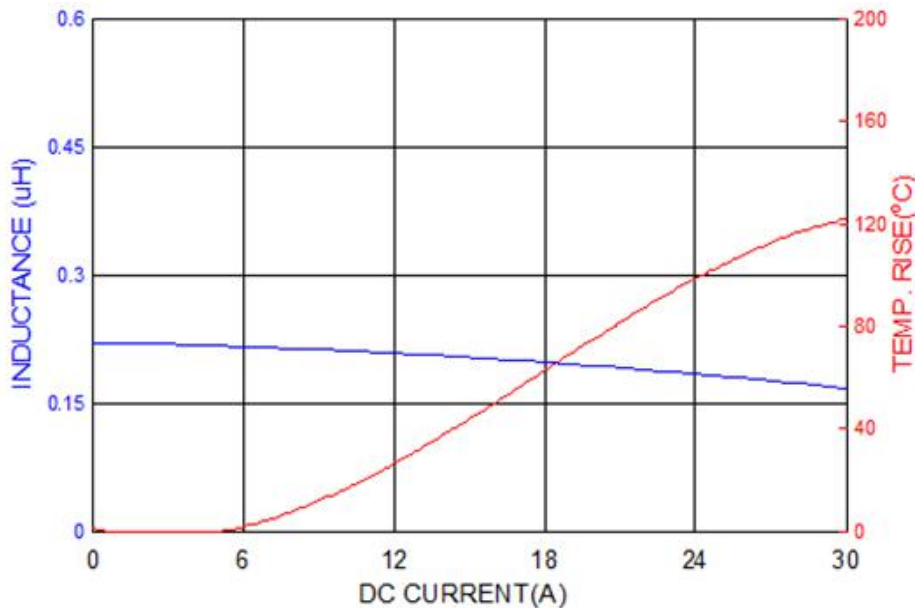
PERFORMANCE CURVES**RECOMMENDED SOLDERING TEMP. GRAPH**

TEMPERATURE (°C)

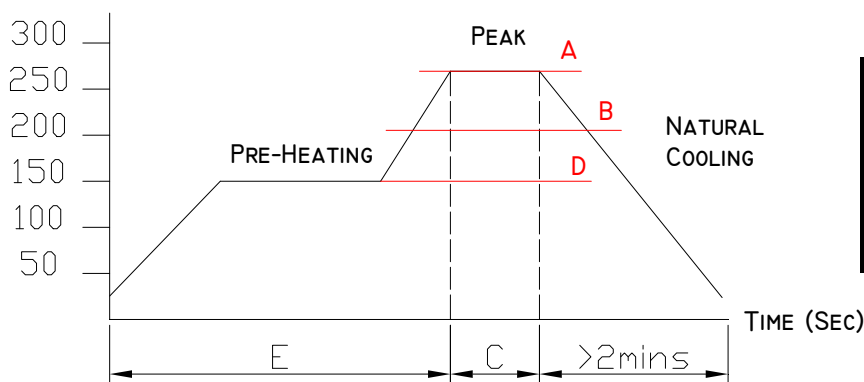

A	260°C
B	230°C
C	10 Sec
D	150°C
E	60~240 Sec

ITEM P/N	PSPMAF0615-R22M-CGF-AP	TEST INSTRUMENT	Zentech-3305 / Zentech502BC
PRODUCT	SMD Inductor	TEST FREQUENCY	100 kHz / 1.0V

MECHANICAL RELIABILITY

TEST	Specification & Requirement	Method Used
Solderability	The surface of terminal/pin tested shall be covered with new solder by 95%	Solder heat proof: Preheating: 180 ±10°C 90 seconds Soldering: 255 ±5°C for 3 ±1 sec
Shock	Inductance change within ± 5% Without mechanical damage	Drop down with 981m/s ² (100G) shock Attitude upon a rubber block method shock testing machinem, 3 tests.
Vibration	Inductance change within ± 5% Without mechanical damage	Vibration frequency: 10Hz to 55Hz to 10Hz 60 seconds cycle Vibration time: 2 hours

ENDURANCE RELIABILITY

TEST	Specification & Requirement	Method Used
Thermal Shock	Inductance change within ± 5% Without mechanical damage	-25°C, (30 mins) -> room temp. (5 mins) -> 125°C, (30 mins) -> room temp. (5 mins) 100 cycles
Heat Resistance	Inductance change within ± 5% Without mechanical damage	Apply IDC current @ 85°C ambient Duration: 1000 hrs
Humidity Resistance	Inductance change within ± 5% Without mechanical damage	Apply IDC current @ 60°C ambient Humidity: 90~95% Duration: 1000 hrs
Low Temp. Storing	Inductance change within ± 5% Without mechanical damage	Storing Temp. -25 ±2 °C for total 1,000 +4/-0 hours
High Temp. Storing	Inductance change within ± 5% Without mechanical damage	Storing Temp. 125 ±2 °C for total 1,000 +4/-0 hours

ITEM P/N	PSPMAF0615-R22M-CGF-AP	TEST INSTRUMENT	Zentech-3305 / Zentech502BC
PRODUCT	SMD Inductor	TEST FREQUENCY	100 kHz / 1.0V

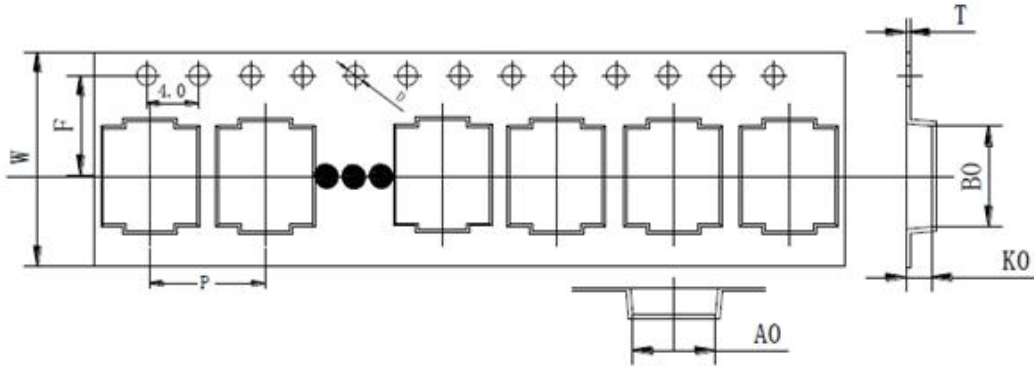
CARRIERTAPEING REEL & CARRIER MATERIALS (PAPER PLASTICS) UNIT : (mm)

Type	A ₀	B ₀	K ₀	P	F	W	D	T
0615HG	7.0±0.1	7.7±0.1	1.8±0.1	12±0.1	7.5±0.1	16±0.3	1.5±0.1	0.35±0.05

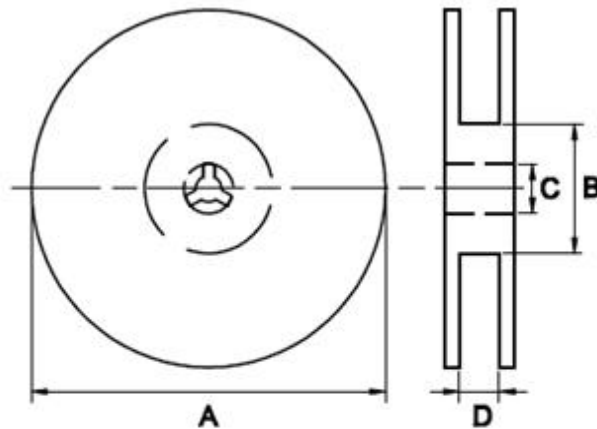

Unit: mm

Type	A	B	C	D
0615HG	330	100±2	13.0±0.5	16.4+2-0

Standard Quantity for Packaging: 2000 pcs/Reel

Page: 4

ITEM P/N	PSPMAF0615-R22M-CGF-AP	TEST INSTRUMENT	Zentech-3305 / Zentech502BC
PRODUCT	SMD Inductor	TEST FREQUENCY	100 kHz / 1.0V

TEST DATA

SPEC No.	A (mm)	B (mm)	C (mm)	D (mm)	E (mm)	DCR Max(mΩ)	INDUCTANCE	
	7.0±0.5	6.6±0.3	1.3 ± 0.2	3.0±0.3	1.8±0.5		L(0) ± 20%	22 A
1	7.22	6.62	1.32	2.91	1.65	4.3	0.23	PASS
2	7.25	6.65	1.33	2.96	1.64	4.6	0.22	PASS
3	7.18	6.68	1.35	2.95	1.68	4.2	0.21	PASS
4	7.15	6.65	1.34	2.91	1.63	4.5	0.22	PASS
5	7.21	6.64	1.32	2.93	1.64	4.1	0.23	PASS
6	7.24	6.66	1.32	2.96	1.68	4.3	0.22	PASS
7	7.16	6.68	1.33	2.91	1.69	4.5	0.21	PASS
8	7.22	6.65	1.33	2.92	1.62	4.2	0.23	PASS
9	7.31	6.68	1.35	2.94	1.64	4.6	0.23	PASS
10	7.23	6.65	1.32	2.91	1.69	4.3	0.21	PASS
\bar{X}	7.22	6.66	1.33	2.93	1.66	4.36	0.22	
R	0.16	0.06	0.03	0.05	0.07	0.50	0.02	

© All test Data is referenced to 25°C ambient

Page: 5



ANNOUNCEMENTS

产品注意事项

使用本产品时，请注意以下事项

- ◎ 产品保存期限为12个月，保存条件：温度5~40℃，湿度10~80%RH以内，超过保存期限可能会使产品端子电极发生氧化。
- ◎ 请勿在极端环境下使用和保存（高盐，强酸，强碱，强辐射等）。
- ◎ 产品焊接前，请进行预热；预热温度与焊接温度之间温差建议控制在150℃以内。
- ◎ 产品焊接后需重新拆卸焊接修正时，请遵循规格书规定的条件范围；过高的加热温度以及反复的拆卸可能会导致产品失效。
- ◎ 产品焊接到线路板后，请注意不可因线路板整体变形或局部变形而施加给电感剩余应力，这可能会导致电感发生破裂，脱落，以致失效。
- ◎ 产品请勿接触清洗剂，酒精等液体，这会侵蚀产品本体，从而导致产品失效。
- ◎ 产品通电后温度会随电流的增大而上升，设计时请务必考虑留有余量。
- ◎ 过高的静电会对产品产生永久性损害，请注意静电防护。
- ◎ 产品通电过程请勿触摸产品任何部位，防止触电。
- ◎ 本产品作为磁性产品，设计时请务必考虑周边元器件与本产品可能产生的相互影响。
- ◎ 本产品适用于一般电子设备，如：AV设备，通信设备，家电产品，娱乐设备，计算机设备，个人设备，办公设备，计测设备，工业机器人等。且该一般电子设备需在常规的操作和使用方法环境下使用。对于需要高度安全性和可靠性的，或者因本产品失效造成设备故障，误操作，运转不良等危及到人的生命身体及财产安全，以及对社会产生较大不良影响的特殊用途，设计使用前务必同本公司沟通，设计使用者如未取得我司书面同意状况下使用造成任何后果，我司不予承担。特殊用途包含但不限于如下清单：
 - 1 军用设备
 - 2 运输设备（汽车，轨道交通产品，船舶等）
 - 3 航空，航天设备
 - 4 发电控制设备
 - 5 核动力相关设备
 - 6 爆炸引燃控制设备
 - 7 交通控制设备
 - 8 关系到国防安全的设备
 - 9 防灾赈灾设备
 - 10 各种安规设备
 - 11 紧急救护设备
 - 12 其他被认定为特殊用途的设备

X-ON Electronics

Largest Supplier of Electrical and Electronic Components

Click to view similar products for [Fixed Inductors](#) category:

Click to view products by [PROD Technology](#) manufacturer:

Other Similar products are found below :

[MLZ1608M6R8WTD25](#) [MLZ1608N6R8LT000](#) [MLZ1608N3R3LTD25](#) [MLZ1608N3R3LT000](#) [MLZ1608N150LT000](#)
[MLZ1608M150WTD25](#) [MLZ1608M3R3WTD25](#) [MLZ1608M3R3WT000](#) [MLZ1608M150WT000](#) [MLZ1608A1R5WT000](#)
[MLZ1608N1R5LT000](#) [B82432C1333K000](#) [PCMB053T-1R0MS](#) [PCMB053T-1R5MS](#) [PCMB104T-1R5MS](#) [CR32NP-100KC](#) [CR32NP-151KC](#) [CR32NP-180KC](#) [CR32NP-181KC](#) [CR32NP-1R5MC](#) [CR32NP-390KC](#) [CR32NP-3R9MC](#) [CR32NP-680KC](#) [CR32NP-820KC](#)
[CR32NP-8R2MC](#) [CR43NP-390KC](#) [CR43NP-560KC](#) [CR43NP-680KC](#) [CR54NP-181KC](#) [CR54NP-470LC](#) [CR54NP-820KC](#) [CR54NP-8R5MC](#)
[ET3542-057](#) [MGDQ4-00004-P](#) [MGDU1-00016-P](#) [MHL1ECTTP18NJ](#) [MHL1JCTTD12NJ](#) [PE-51506NL](#) [PE-53601NL](#) [PE-53630NL](#) [PE-53824SNLT](#) [PE-62892NL](#) [PE-92100NL](#) [PG0434.801NLT](#) [PG0936.113NLT](#) [PM06-2N7](#) [PM06-39NJ](#) [HC2LP-R47-R](#) [HC2-R47-R](#) [HC3-2R2-R](#)