

產品編碼 P/N	PSTFAQ3416-600T020	測試設備 TEST INSTRUMENT	Keysight:E4991B Chroma:16502 3302
產品系列 Series	贴片微型网口变压器	測試頻率 TEST FREQUENCY	100KHZ / 0.1V

客戶名稱
Customer :

客戶編碼
Customer P/N :

產品系列
Series : 贴片微型网口变压器
SMD miniature transformer

產品編碼
Supply P/N : PSTFAQ3416-600T020

發版號
Version : A2.0

承認日期
Endorsement Date : 2022-5-5

備註
Note :

譜羅德電子科技（深圳）有限公司 PROD Electronic Technology (Shenzhen) Co. LTD	
製作 APPROVED	Ben
審查 CHECKED	Yuki
確認 PREPARED	Peter

客戶承認 Customer Approval

客戶簽章



產品編碼 P/N	PSTFAQ3416-600T020	測試設備 TEST INSTRUMENT	Keysight:E4991B Chroma:16502 3302
產品系列 Series	贴片微型网口变压器	測試頻率 TEST FREQUENCY	100KHZ / 0.1V

封裝尺寸 Dimension (mm)

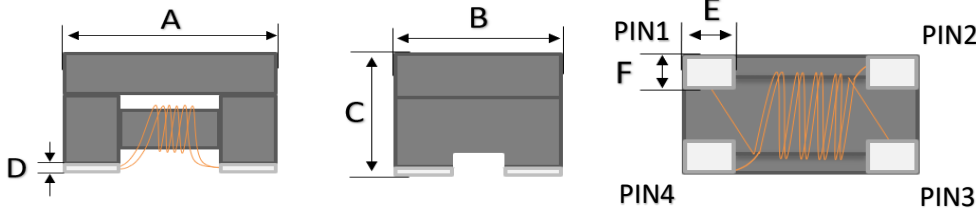

封裝尺寸 Dimension	
A	3.4±0.2
B	1.6±0.2
C	2.0±0.2
D	0.12 Typ
E	0.66 Typ
F	0.64 Typ

推薦的焊盤尺寸 Recommened Land Pattern

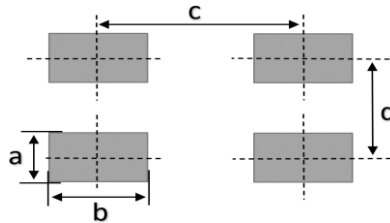

焊盤尺寸 Land Pattern Dimension	
a	0.9 Typ
b	0.9 Typ
c	2.74 Typ
d	0.96 Typ

編碼解釋 Code interpretation

PSTFAQ

類別碼

Category code

3416

尺寸系列

Dimension

600

感值

Inductance

T020

額定電流

Rated Current

電氣參數 Electrical Characteristics

產品編碼 P/N	@ 25 °C Ambient Temperture					
	感值 Inductance	精度 Tolerance	DCR	絕緣性 (IR)	額定電流 (Rated Current)	額定電壓 (Rated Voltage)
			Ω	MΩ		
μH	Min(μH)	Max	Min	mA	V	
PSTFAQ3416-600T020	60	60	1.7	10	200	50

- ◎ 規格參數基於環境溫度25°C取得
All test Data is referenced to 25°C ambient
- ◎ 電感工作環境溫度：-25°C ~ 105°C
Operating temperature range -25 °C to +105 °C
- ◎ 加載額定電流會使電感溫度上升大約 40°C (電感初始溫度+上升溫度=電感最終溫度)
Typical Heat Rating DC Current would cause an approximately ΔT of 40°C
- ◎ 務必考慮最終的產品設計，元器件佈局，線路板走線，以及使用環境過程中，電感最終溫度不得超過105°C
The operating temperature of inductance do not exceed 105°C
- ◎ 參考產品開發設計實測尺寸，感值，DCR等數據，請參考規格書第7頁
The Dimension, Inductance ,DCR test data is on page 7
- ◎ 使用電感時，請查閱第8頁注意事項
The announcements is on page 9

特性 CHARACTERISTICS



產品編碼 P/N	PSTFAQ3416-600T020	測試設備 TEST INSTRUMENT	Keysight:E4991B Chroma:16502 3302
產品系列 Series	贴片微型网口变压器	測試頻率 TEST FREQUENCY	100KHZ / 0.1V

電路結構 Schematic

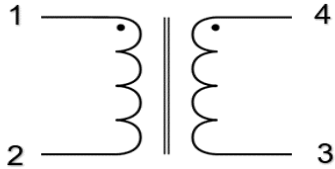

产品图示 Image



- ◎ 電感內置兩組線圈
Inductor Contents Two (2) Set(s) of Coil

产品结构 Structure

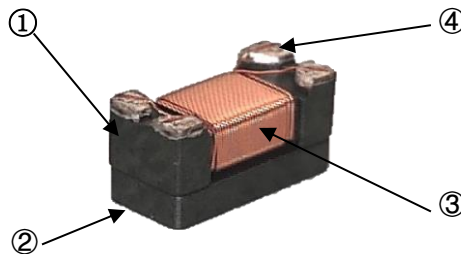

序号 NO.	名称 Description	材料规格 materials Specification
1	磁芯/Core	铁氧体磁芯/Ferrite Core
2	顶盖/Cover	铁氧体/Ferrite
3	铜线/Enamelled wire	漆包线/Enamelled wire
4	电极/Electrode	锡/Sn

焊接溫度（推荐）

Recommended Soldering Temperature Graph

TEMPERATURE (°C)

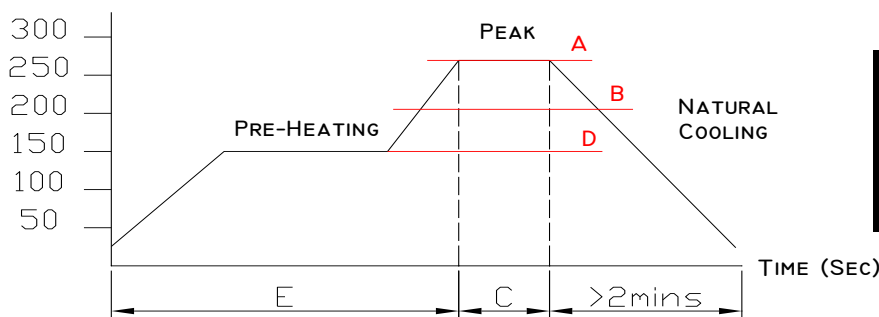

A	260°C
B	230°C
C	10 Sec
D	150°C
E	60~240 Sec



產品編碼 P/N	PSTFAQ3416-600T020	測試設備 TEST INSTRUMENT	Keysight:E4991B Chroma:16502 3302
產品系列 Series	贴片微型网口变压器	測試頻率 TEST FREQUENCY	100KHZ / 0.1V

典型电路 (单口10M/100M)

Typical Application Circuit (Single-port 10M/100M)

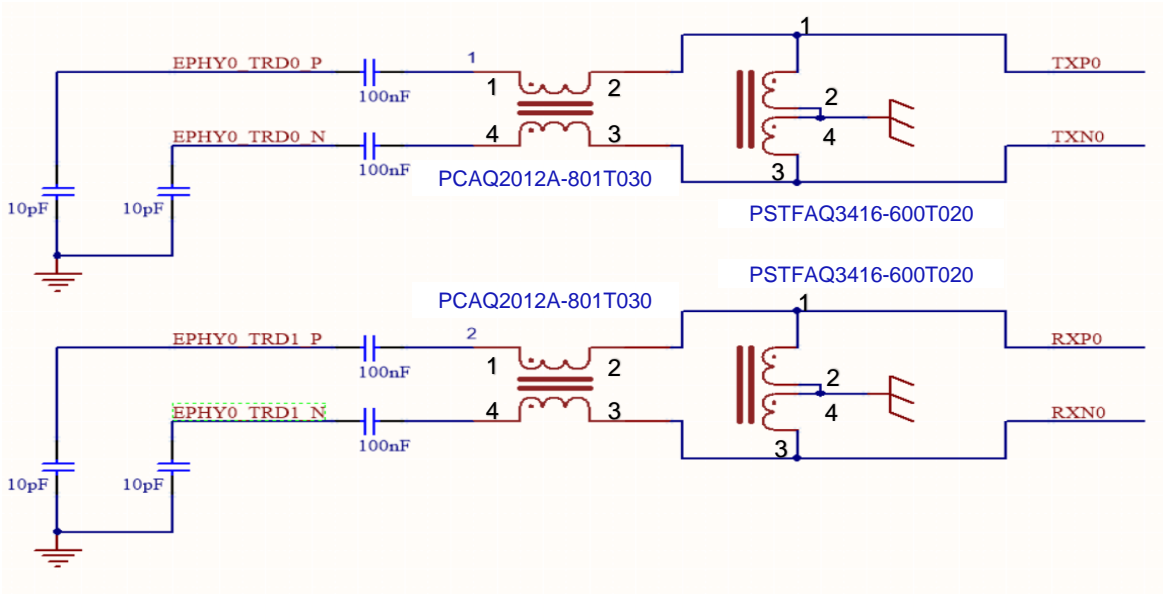

USB



測試數據

TEST REPORT



產品編碼 P/N	PSTFAQ3416-600T020	測試設備 TEST INSTRUMENT	Keysight:E4991B Chroma:16502 3302
產品系列 Series	贴片微型网口变压器	測試頻率 TEST FREQUENCY	100KHZ / 0.1V

測試數據

Test Date

序號	尺寸測試數據			特性測試數據		
	Dimension Test Date			Characteristics Test Date		
	A	B	C	DCR	L	Judge
	mm	mm	mm	ΩMax	Min(μH)60	
	3.4±0.2	1.6±0.2	2.0±0.2	1.7	60.00	
1	3.42	1.63	1.98	1.24	67	PASS
2	3.43	1.61	1.97	1.27	65	PASS
3	3.42	1.62	1.98	1.23	61	PASS
4	3.43	1.62	2.01	1.28	67	PASS
5	3.41	1.62	1.98	1.27	62	PASS
6						PASS
7						PASS
8						PASS
9						PASS
10						PASS
平均值	1.711	0.81	0.992	0.629	32.2	
R	0.02	0.02	0.04	0.05	6.00	

◎ 所有测试数据基于环境温度25℃取得
All test Data is referenced to 25℃ ambient



產品編碼 P/N	PSTFAQ3416-600T020	測試設備 TEST INSTRUMENT	Keysight:E4991B Chroma:16502 3302
產品系列 Series	贴片微型网口变压器	測試頻率 TEST FREQUENCY	100KHZ / 0.1V

載帶卷盤尺寸 : (mm)

Packing Dimension

MPQ	R	H	A	B	P	Po	W	Ko
2000pcs/卷盤	178	8.5	1.9	3.7	4	4	8	2.3

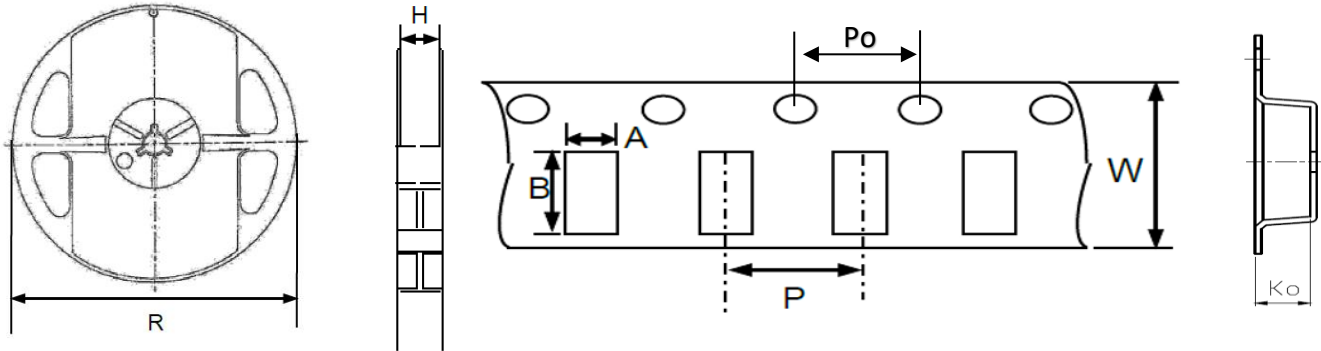

載帶剝離力:

Typical Pulling Force

對上蓋帶施加力: 20g~120g內即可與下載帶剝離

Tape Peeling off force: 20g~120g

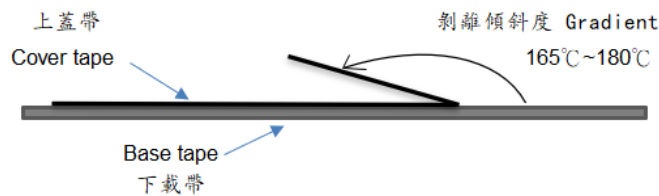

裝箱數量:

Package Quantity

2000pcs/卷盤
2000pcs/Reel

10000pcs/每盒
10000pcs/ Middle box

50000pcs/每箱
50000pcs/ Outer box

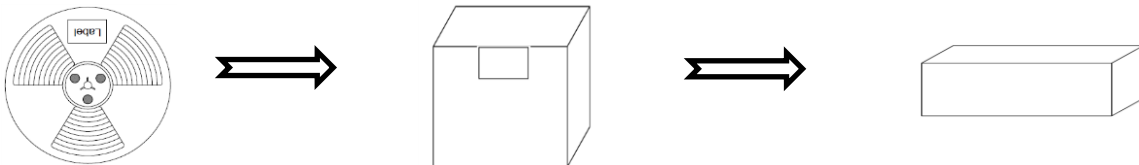

© 實際出貨過程, 依據客戶需求狀況的不同, 包裝數量會有變化, 最終的包裝數量請參照實際出貨包裝
In the actual delivery process, the package quantity will change according to the different customer demands. Please refer to the actual shipment quantity for the final package quantity





注意事項

使用本產品時，請注意以下事項

- ◎ 產品保存期限為12個月，保存條件：溫度5~40℃，濕度10~75%RH以內，超過保存期限可能會使產品端子電極發生氧化。
- ◎ 請勿在極端環境下使用和保存（高鹽，強酸，強鹼，強輻射等）。
- ◎ 產品焊接前，請進行預熱；預熱溫度與焊接溫度之間溫差建議控制在150℃以內。
- ◎ 產品焊接後需重新拆卸焊接修正時，請遵循規格書規定的條件範圍；過高的加熱溫度以及反復的拆卸可能會導致產品失效。
- ◎ 產品請勿接觸清洗劑，酒精等液體，這會侵蝕產品本體，從而導致產品失效。
- ◎ 產品焊接到線路板後，請注意不可因線路板整體變形或局部變形而施加給電感剩餘應力，這可能會導致電感發生破裂，脫落，以致失效。
- ◎ 產品通電後溫度會隨電流的增大而上升，設計時請務必考慮留有餘量。
- ◎ 過高的靜電會對產品產生永久性損害，請注意靜電防護。
- ◎ 產品通電過程請勿觸摸產品任何部位，防止觸電。
- ◎ 本產品作為磁性產品，設計時請務必考慮周邊元器件與本產品可能產生的相互影響。
- ◎ 本產品適用於一般電子設備，如：AV設備，通信設備，家電產品，娛樂設備，電腦設備，個人設備，辦公設備，計測設備，工業機器人等。且該一般電子設備需在常規的操作和使用方法環境下使用。對於需要高度安全性和可靠性的，或者因本產品失效造成設備故障，誤操作，運轉不良等危及到人的生命身體及財產安全，以及對社會產生較大不良影響的特殊用途，設計使用前務必同本公司溝通，設計使用者如未取得我司書面同意狀況下使用造成任何後果，我司不予承擔。特殊用途包含但不限定如下清單：
 - 1 軍用設備
 - 2 運輸設備（汽車，軌道交通產品，船舶等）
 - 3 航空，航太設備
 - 4 發電控制設備
 - 5 核動力相關設備
 - 6 爆炸引燃控制設備
 - 7 交通控制設備
 - 8 關係到國防安全的設備
 - 9 其他被認定為特殊用途的設備





ANNOUNCEMENTS

Please read this before using the product.

- © The product storage life is 12 months, Storage Temperature: TEMP.5~40°C; RH10%~75%. Please use the product within the warranty period
- © Do not use or store in locations where there are conditions such as gas corrosion (salt, acid, alkali, radiation etc.) .
- © Before soldering, be sure to preheat components:The preheating temperature should be set so that The temperature difference between the solder temperature and chip temperature does not exceed 150° C.
- © Soldering corrections after mounting should be within the range of the conditions determined in the specifications. If overheated, a short circuit, performance deterioration, or lifespan shortening may occur. Repeated disassembly may invalidate the inductance
- © The cleaning agent can not be used for these products. This may corrode the inductor
- © When embedding a printed circuit board where a chip is mounted to a set, be sure that residual stress is not given to the chip due to the overall distortion of the printed circuit board and partial distortion such as at screw tightening portions.
- © Self heating (Rated Current or Irms) occurs when the power is turned ON, so the tolerance should be sufficient for the set thermal design.
- © Too high static electricity will cause permanent damage to the product, please pay attention to electrostatic protection.
- © As a magnetic product, the design must consider the possible interaction between peripheral components and the product.
- © The products listed on this catalog are intended for use in general electronic equipment (AV equipment, telecommunications equipment, home appliances, amusement equipment, computer equipment, personal equipment, office equipment, measurement equipment, industrial robots) under a normal operation and use condition.

The products are not designed or warranted to meet the requirements of the applications listed below, whose performance and/or quality require a more stringent level of safety or reliability, or whose failure, malfunction or trouble could cause serious damage to society, person or property.

If you intend to use the products in the applications listed below or if you have special requirements exceeding the range or conditions set forth in the each catalog, please contact us. Otherwise, our

- | | |
|--------------------------------------------------------|---------------------------------------------------------------------------|
| 1 Military equipment | 8 Medical equipment |
| 2 Transportation equipment (cars, trains, ships, etc.) | 9 Other applications that are not considered general-purpose applications |
| 3 Aerospace/aviation equipment | |
| 4 Power-generation control equipment | |
| 5 Atomic energy-related equipment | |
| 6 Explosive ignition control equipment | |
| 7 Transportation control equipment | |



X-ON Electronics

Largest Supplier of Electrical and Electronic Components

Click to view similar products for [Audio Transformers / Signal Transformers](#) category:

Click to view products by [PROD Technology](#) manufacturer:

Other Similar products are found below :

[CU4S0506AT-2655-H1](#) [CX2041NLT](#) [MGPWT-00449-P](#) [PE-64961](#) [H1302FNLT](#) [H5008FNL](#) [H5012FNL](#) [H5020FNLT](#) [H5077NLT](#)
[H5079NLT](#) [H5084FNLT](#) [1812WBT2-4](#) [1879479-1](#) [HX2260FNL](#) [PA1528ANL](#) [EX2024FNL](#) [T1137NLT](#) [T3012NL](#) [PE-65812FNL](#) [PE-65848FNLT](#) [H1174FNL](#) [H1302FNL](#) [H5015FNL](#) [H5019EFNL](#) [H5062FNLT](#) [CX2047LNL](#) [MET-14](#) [MGPWT-00059-P](#) [MGPWT-00266-P](#)
[MGPWT-00278-P](#) [MGPWT-00431-P](#) [TTC-100](#) [TTC-143-H](#) [BX1194WNLT](#) [HX1234NLT](#) [HX5008FNLT](#) [HX5019FNL](#) [HX5084NL](#) [3-1879385-5](#) [TX1263NLT](#) [4-1879391-0](#) [100213](#) [T1142NL](#) [HX6101FNL](#) [HX5084FNL](#) [HX1148NL](#) [HX5020FNLT](#) [HX5014FNLT](#) [T1124NL](#)
[1879732-1](#)