



PL2586

USB 2.0 High Speed 4-Port Hub Controller

Product Datasheet

Document Revision: 1.2

Document Release: May 27, 2022

Prolific Technology Inc.

7F, No. 48, Sec. 3, Nan Kang Rd.

Nan Kang, Taipei 115, Taiwan, R.O.C.

Tel: 886-2-2654-6363 / Fax: 886-2-2654-6161

Email: sales@prolific.com.tw

Home URL: <http://www.prolific.com.tw>

Tech URL: <http://tech.prolific.com.tw>

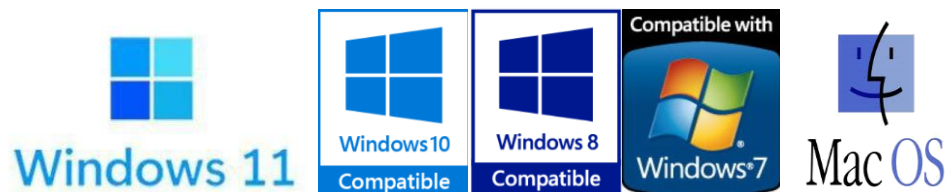

REVISION HISTORY

Revision	Description	Date
1.2	<ul style="list-style-type: none">➤ Modified Package type QFN24 MPQ information➤ Modified Storage Temperature range from -55 ~ 150 to -40 to 150 °C	2022/5/27
1.1	<ul style="list-style-type: none">➤ Added QFN24 package IC Bottom PAD information of pin assignment➤ Modified pin description	2022/3/9
1.0	<ul style="list-style-type: none">➤ Modified chip version of ordering information from A1 to A2➤ Added TID of USB Compliance test	2022/2/9
0.1	<ul style="list-style-type: none">➤ Initial Version	2021/5/18

Table of Contents

1. Description.....	4
2. Features.....	5
3. Ordering Information.....	6
4. Block Diagram.....	6
5. USB Logo Certification	7
6. Pin Assignment.....	8
6.1 QFN24 Pin Diagram	8
6.2 SSOP28 Pin Diagram.....	9
6.3 Pin Description (QFN24 & SSOP28)	10
7. Data Format Defined in EEPROM	13
8. USB3 & USB2 HUB Command Verifier.....	16
8.1 USB3 HUB Command Verifier	16
8.2 USB2 HUB Command Verifier	18
9. Electrical Characteristics	20
9.1 Absolute Maximum Ratings.....	20
9.2 Operating Conditions	20
9.3 DC Characteristics.....	20
9.4 Power on Sequence.....	21
10. Power consumption	22
10.1 Measurement with the total device consumption.....	22
11. Package Outline.....	24
11.1 QFN24 Outline.....	24
11.2 SSOP28 Outline	25
12. Package Information	26
12.1 Carrier Tape (SSOP-28)	26
12.2 Carrier Tape (QFN24).....	27

1. Description

The PL2586 is a high performance solution for USB 2.0 High Speed 4-port hub controller with fully compliant with Universal Serial Bus Specification 2.0. The controller inherits advanced serial interface technology to consume the least power when 4 DS (downstream) ports function simultaneously.

The PL2586 is an innovation that integrates function to comply with USB-IF “Battery Charging Specification Revision 1.2”, which supports fast charging function for portable devices. This feature turns PL2586 into a USB Charging Hub for “Universal Charging Solution”, (UCS) compliant battery based portable devices, promoted by GSMA. The dedicate port in PL2586 can handle the charging request when B.C. compliant portable device is detected on the downstream port. And, after the handshake has been completed, PL2586 allows portable devices to draw up to 500mA (High speed); 1.5A (Low/Full speed) from charging downstream ports (CDP) or 1.5A from dedicated charging port (DCP).

PL2586 adapt Single Transaction Translator (STT) and Ganged power management to achieve cost effective purpose. Users can also implement multiple Hub configuration options through external EEPROM.

PL2586 supports QFN24 and SSOP28 packages targeting mainstream stand-alone 4 ports Hub market.

2. Features

- Compliant with USB Specification Revision 2.0
 - Upstream Port supports high-speed (480MHz) and full-speed (12MHz) traffic
 - Configurable 4/3/2 downstream ports support high-speed, full-speed, and low-speed
 - Backward compatible to USB Specification Revision 1.1
- Compliant with USB Battery Charging Specification Revision 1.2
- Integrated Fast 8051 microprocessor
- 12MHz Oscillator clock input
- Integrated upstream 1.5K Ω pull-up downstream 15K Ω pull-down resistors
- Single Transaction Translator (Single TT)
- Ganged Power Control and Global Over Current detection for downstream ports
- Leading small power consumption USB2.0 Hub
- On chip 5V to 3.3V and 3.3V to 1.2V regulator
- Automatic re-enumeration for switching between self-powered and bus-powered modes
- External EEPROM interface for customized information storage
 - Customized VID, PID
 - Number of downstream port
 - Product ID
 - Serial number
- Two LED port indicator mode
 - 4 Downstream port LED (enable green) and one Active/Suspend LED (Red)
 - One joint Downstream port LED for 4 ports (enable green) and one Active/Suspend LED(Red)
- Type of packages
 - QFN24
 - SSOP28

3. Ordering Information

Chip Product Name	Package Type	Ordering Part Number	MPQ
PL2586	28-pin SSOP	PL2586A2ZJG7P1	50 pcs / tube
		PL2586A2ZJG8P1	2500pcs / reel
	24-pin QFN	PL2586A2FIG8P1	3000 pcs / reel

4. Block Diagram

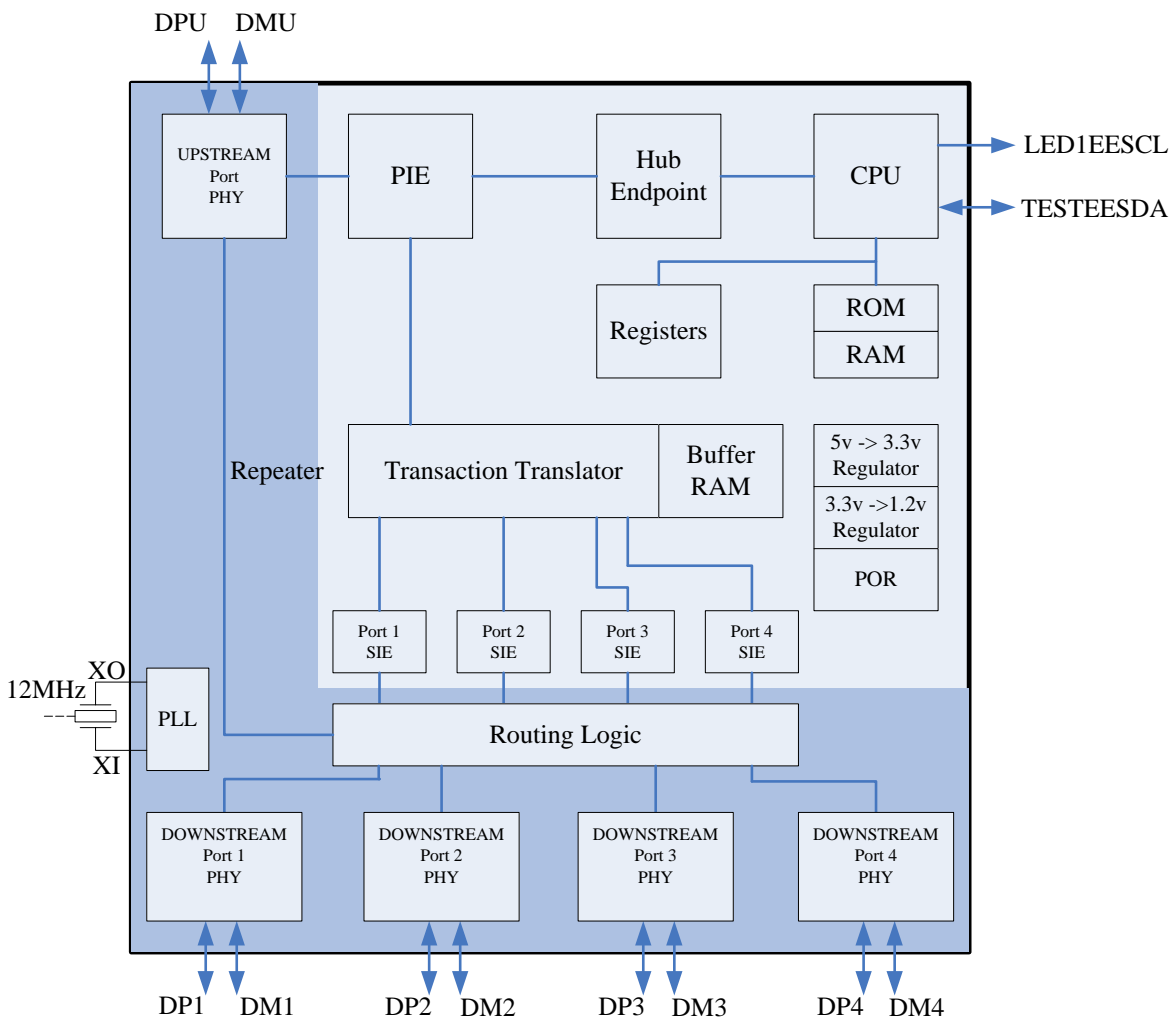

5. USB Logo Certification

The PL2586 IC has been certified by the USB-IF organization with TID 6701 to be fully compliant with the USB 2.0 specification.



6. Pin Assignment

6.1 QFN24 Pin Diagram

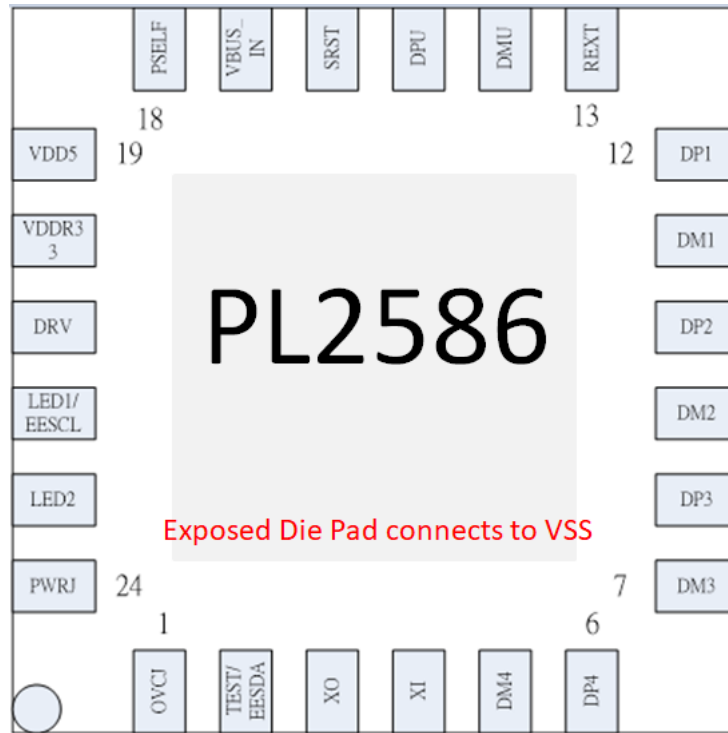

6.2 SSOP28 Pin Diagram

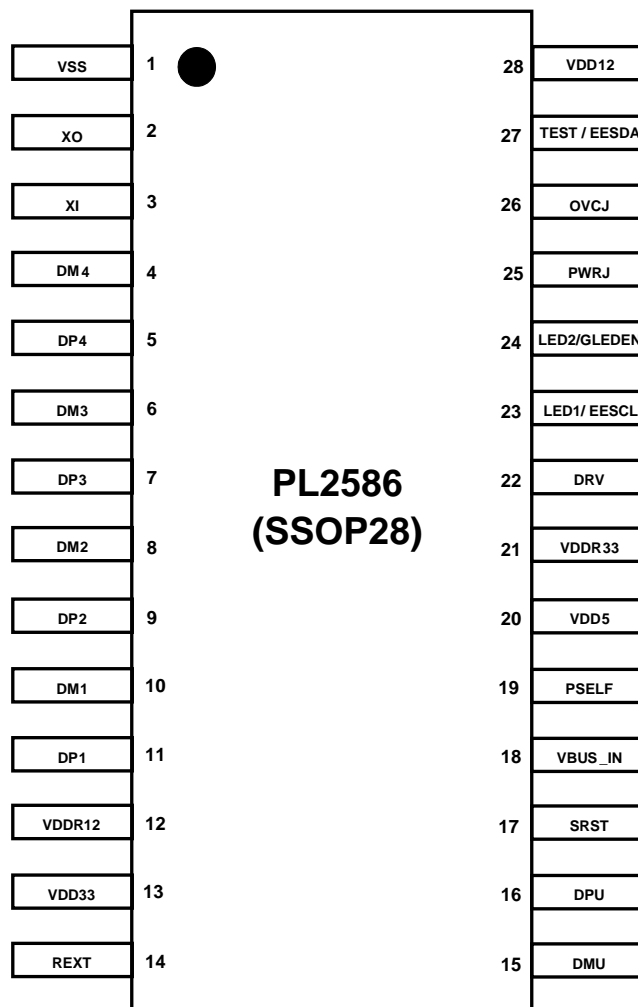

6.3 Pin Description (QFN24 & SSOP28)

QFN24 Pin #	SSOP28 Pin #	Pin Name	I/O	Description
1	26	OVCJ	B	Global over current detection indicator for 4 DSP, active low. (Default: pull up)
2	27	TEST / EESDA	B	Test mode enable / EEPROM data pin, (Default: pull up) . For normal usage this EESDA pin should left as No-Connection or connect to EEPROM SDA pin. Active low.
3	2	XO	P	12MHz Crystal Oscillator output
4	3	XI	P	12MHz Crystal Oscillator input
5	4	DM4	B	USB D- pin for the 4 th Downstream Port
6	5	DP4	B	USB D+ pin for the 4 th Downstream Port
7	6	DM3	B	USB D- pin for the 3 rd Downstream Port
8	7	DP3	B	USB D+ pin for the 3 rd Downstream Port
9	8	DM2	B	USB D- pin for the 2 nd Downstream Port
10	9	DP2	B	USB D+ pin for the 2 nd Downstream Port
11	10	DM1	B	USB D- pin for the 1 st Downstream Port
12	11	DP1	B	USB D+ pin for the 1 st Downstream Port
13	14	REXT	I	USB PHY bias reference
14	15	DMU	B	USB D- pin for the Upstream Port
15	16	DPU	B	USB D- pin for the Upstream Port
16	17	SRST	I	System reset pin (Default: pull up)
17	18	VBUS_IN	I	USB Vbus facing port. Used to monitor the power state of Vbus. When Vbus_in = 1, the chip starts function.
18	19	PSELF	B	a. Bus power monitor. Distinguish the power source is Self-powered or Bus-powered. (High level indicates Self-Powered; Low level indicates Bus-Powered; (Default pull-up)) b. pin can support DCP mode with Vbus connected. c. When charge function enabled (DRV pull-high), and PSELF pull to low, DP1/DM1 resume to only data transfer mode.

19	20	VDD5	P	5V input for LDO
20	21	VDDR33	P	3.3V output from 5V LDO
21	22	DRV	B	<p>LED control / Charging Hub Enable (Default: pull down)</p> <p>a. When chip normal function(without enabling the charging mode), this DRV pin is responsible for indicating the Hub active/suspends status, tie to GND. (refer to schematic)</p> <p>b. When enabling charge function, (DRV pull high to VCC), 4 downstream ports will support BC1.2 (SDP/CDP/DCP) fast charge with power adaptor connected</p> <p>b1. PL2586 auto-detect device is BC1.2</p> <p>b2. In CDP mode with Vbus connected, PL2586 supports data communication and fast charge. (500mA for HS device)</p> <p>b3. In DCP mode with Vbus disconnected, PL2586 supports fast charge with up to 1.5A , similar to wall adaptor (refer to schematic)</p>
22	23	LED1/ EESCL	B	<p>DSP 1 and DSP 3 LED control / EEPROM clock. (Default: pull down)</p> <p>a. When using 4LED for each downstream port, this LED1 pin is responsible for port1 and port3 control. (refer to schematic)</p> <p>b. When LED2 is pull high during initiate, LED1 act as the LED indicator for all 4ports.</p> <p>c. Clock of EEPROM (SCL)</p>
23	24	LED2/ GLEDEN	B	<p>DSP 2 and DSP 4 LED control/Group LED Indicator Enable. (Default: pull down)</p> <p>a. When using 4LED for each downstream port, this LED2 pin is responsible for</p>

Product Data Sheet

PL2586 (USB 2.0 High Speed 4-Port Hub Controller)



				port2 and port4 control. (refer to schematic) b. When using 1LED for 4 downstream port, this LED2 pin is responsible for enable Group LED indicator (GLEDEN), with it pull high to 3.3V (refer to schematic)
24	25	PWRJ	B	Power switch enable power for 4 DSP devices in Ganged powered mode, active low. (Default: pull up)
-	1	VSS	P	Ground
-	12	VDDR12	P	1.2V output from 3.3V to 1.2VLDO
-	13	VDD33	P	3.3V input for 3.3V to 1.2VLDO
-	28	VDD12	P	1.2V power input
IC Bottom PAD		VSS	P	Connects to VSS

I/O Type Definition

O : Output

B : Bi-directional

I : Input

P : Power

7. Data Format Defined in EEPROM

This controller supports in-system customization to fulfill wide range of applications without controller re-spin. This is achieved via non-volatile memory of low density two-wire serial EEPROM. This type of memory is widely-used industrial standard hence make it the cost-efficient solution for customization and vastly ease time-to-market curve.

Table 7-1 of EEPROM array.

Offset (Hex)	Size (Dec)	Description
0x00	1	Validation byte 0. There are 7 validation bytes across EEPROM array to check possibly corruption of valid data. These validation bytes are generated dynamically according to content of EEPROM array. Any value other than generated will invalidate the EEPROM content and the controller will not load value from EEPROM during initialization.
0x01	1	Validation byte 1.
0x02	1	idVendor of USB Standard Device Descriptor. Big-endian.
0x03	1	idVendor of USB Standard Device Descriptor. Big-endian.
0x04	1	idProduct of USB Standard Device Descriptor. Big-endian.
0x05	1	idProduct of USB Standard Device Descriptor. Big-endian.
0x06	1	bcdDevice of USB Standard Device Descriptor. Big-endian.
0x07	1	bcdDevice of USB Standard Device Descriptor. Big-endian.
0x08 ~ 0x19	18	Reserved. Fill 0x00
0x1A	1	Number of downstream facing ports in Hub Descriptor. 0x1: 1 downstream facing port is supported by this hub. 0x2: 2 downstream facing ports are supported by this hub. 0x3: 3 downstream facing ports are supported by this hub. 0x4: 4 downstream facing ports are supported by this hub. Other value: invalid
0x1B ~	14	Reserved. Fill 0x00

Product Data Sheet
PL2586 (USB 2.0 High Speed 4-Port Hub Controller)



		''''''
0x48	1	Length of string descriptor describing serial number (offset 0x49~0x54). This field represents length of characters and will be automatically converted to bLength format of String Descriptor. Maximum value of this field is 12. If this byte is 0x00 or 0xFF then no serial number string will be reported.
0x49 ~ 0x54	12	ASCII coded data of string descriptor describing serial number, indicated by iSerialNumber of USB Standard Device Descriptor. The array here is ASCII coded and will be automatically converted to Unicode coded in forming String Descriptor. Example: '0', '1', '2', '3', '4', '5', '6', '7', '8', '9', 'A', 'B'
0x55	1	Bit[7:4]: reserved, do not use bit[3] : DeviceRemovable indicator of downstream facing port 4 of Hub Descriptor 0b: device is removable 1b: device is non-removable bit[2] : DeviceRemovable indicator of downstream facing port 3 of Hub Descriptor 0b: device is removable 1b: device is non-removable bit[1] : DeviceRemovable indicator of downstream facing port 2 of Hub Descriptor 0b: device is removable 1b: device is non-removable bit[0] : DeviceRemovable indicator of downstream facing port 1 of Hub Descriptor 0b: device is removable 1b: device is non-removable
0x56	1	Validation byte 5.
0x57	1	Validation byte 6.
Other offset	-	Reserved for future use.

Note: Contact Prolific representative for EEPROM tooling.

8. USB3 & USB2 HUB Command Verifier

8.1 USB3 HUB Command Verifier

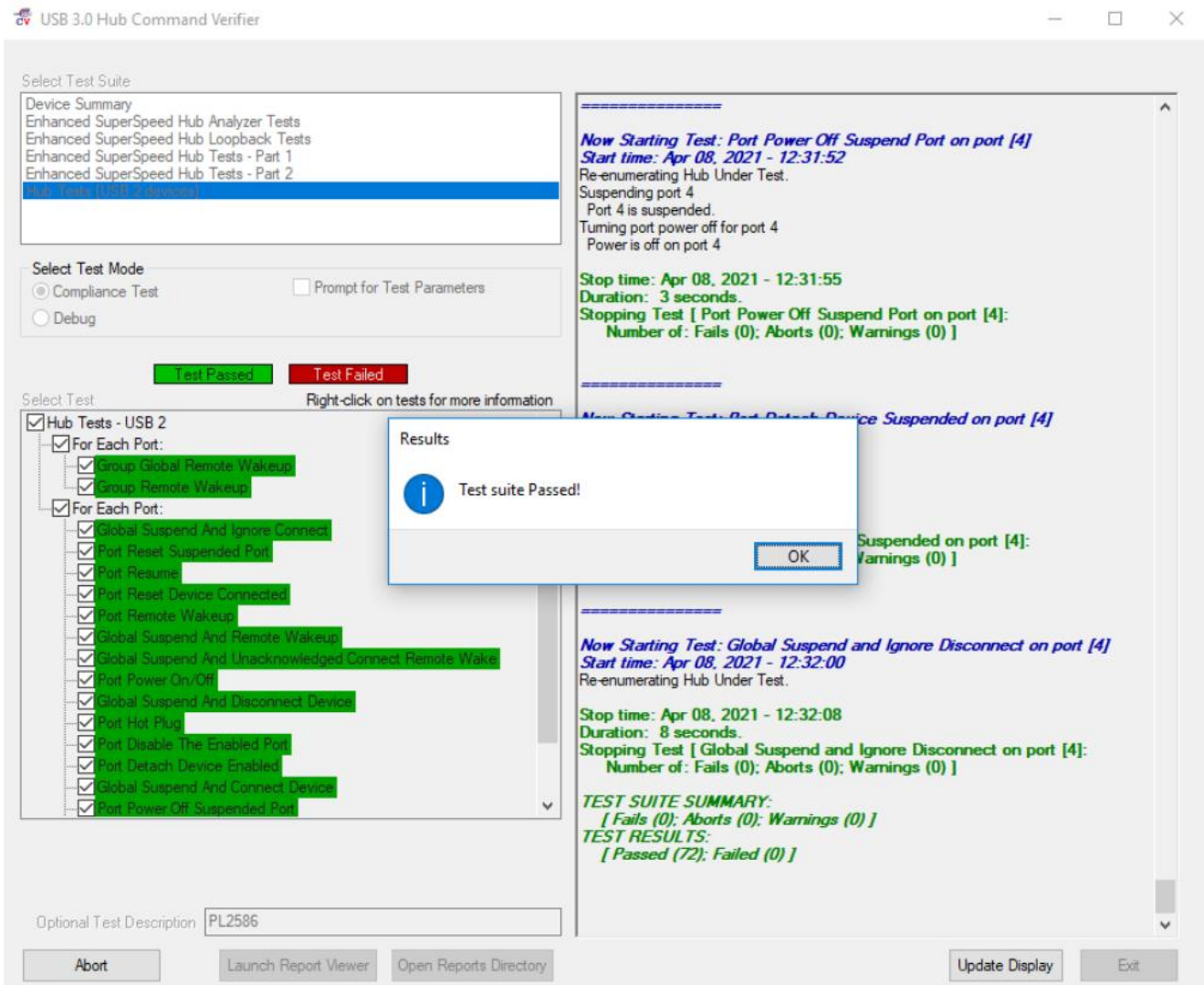

The screenshot displays the 'USB 3.0 Hub Command Verifier' application window. On the left, the 'Select Test Suite' list includes 'Enhanced SuperSpeed Hub Tests - Part 2', which is selected. Below it, 'Select Test Mode' is set to 'Compliance Test'. The 'Select Test' tree shows 'Hub Tests - USB 2' expanded, with various sub-tests checked, such as 'Group Global Remote Wakeup' and 'Global Suspend And Ignore Disconnect on port [4]'. A 'Results' dialog box is open in the center, displaying an information icon and the text 'Test suite Passed!'. The main window's right pane shows test logs for two tests: 'Port Power Off Suspend Port on port [4]' and 'Global Suspend and Ignore Disconnect on port [4]'. Both tests show a duration and a summary of results: 'Number of: Fails (0); Aborts (0); Warnings (0)'. At the bottom, a 'TEST SUITE SUMMARY' indicates '[Passed (72); Failed (0)]'. Buttons for 'Abort', 'Launch Report Viewer', 'Open Reports Directory', 'Update Display', and 'Exit' are visible at the bottom of the window.

Product Data Sheet PL2586 (USB 2.0 High Speed 4-Port Hub Controller)



USB 3 Gen X Command Verifier

Select Test Suite

- Billboard Tests
- Chapter 9 Tests [USB 2 devices]**
- Chapter 9 Tests [USB 3 Gen X devices]
- Connector Type Tests
- Current Measurement Test [USB 2 devices]
- Current Measurement Test [USB 3 Gen X devices]
- Device Summary
- HID Tests
- Link Layer Test for Gen 1

Select Test Mode

Compliance Test Prompt for Test Parameters

Debug

Select Test

Right-click on tests for more information

- Chapter 9 Tests - USB 2
 - Chapter 9 Tests
 - For Each Configuration:
 - Default State
 - TD 9.1: Device Descriptor Test
 - TD 9.2: Configuration Descriptor Test
 - TD 9.3: Interface Association Descriptor Test
 - TD 9.4: Interface Descriptor Test
 - TD 9.5: Endpoint Descriptor Test
 - TD 9.7: BOS Descriptor Test
 - TD 9.30 Configuration Summary Descriptor Test
 - Addressed State
 - TD 9.1: Device Descriptor Test
 - TD 9.2: Configuration Descriptor Test
 - TD 9.3: Interface Association Descriptor Test
 - TD 9.4: Interface Descriptor Test
 - TD 9.5: Endpoint Descriptor Test
 - TD 9.7: BOS Descriptor Test

Optional Test Description: PL2586

Abort Launch Report Viewer Open Reports Directory Update Display Exit

Endpoint descriptor length : 0x7
Endpoint descriptor type : 0x5
Endpoint Type : Interrupt, Number : 0x1, Direction : IN
Endpoint descriptor bmAttributes : 0x3
Endpoint descriptor raw MaxPacketSize : 0x1
Endpoint descriptor interval : 0xFF

Stop time: Apr 08, 2021 - 12:14:00
Duration: 1 second.
Stopping Test [TD 9.5 - Endpoint Descriptor Test (Configuration Index 0 OtherSpeedConfiguration Index 0) - configured:
Number of: Fails (0); Aborts (0); Warnings (0)]

Now Starting Test: TD 9.16 - Enumeration Test(repeat 150 times)
Start time: Apr 08, 2021 - 12:14:00
Device speed is High.
Beginning enumeration test with 150 enumerations. This may take several minutes to complete.

.....	25 enumerations
.....	50 enumerations
.....	75 enumerations
.....	100 enumerations
.....	125 enumerations
.....	150 enumerations

Number of: Fails (0); Aborts (0); Warnings (0)]

150 times):

Number of: Fails (0); Aborts (0); Warnings (0)]

TEST SUITE SUMMARY:
[Fails (0); Aborts (0); Warnings (0)]
TEST RESULTS:
[Passed (36); Failed (0)]

Results

Test suite Passed!

OK

8.2 USB2 HUB Command Verifier

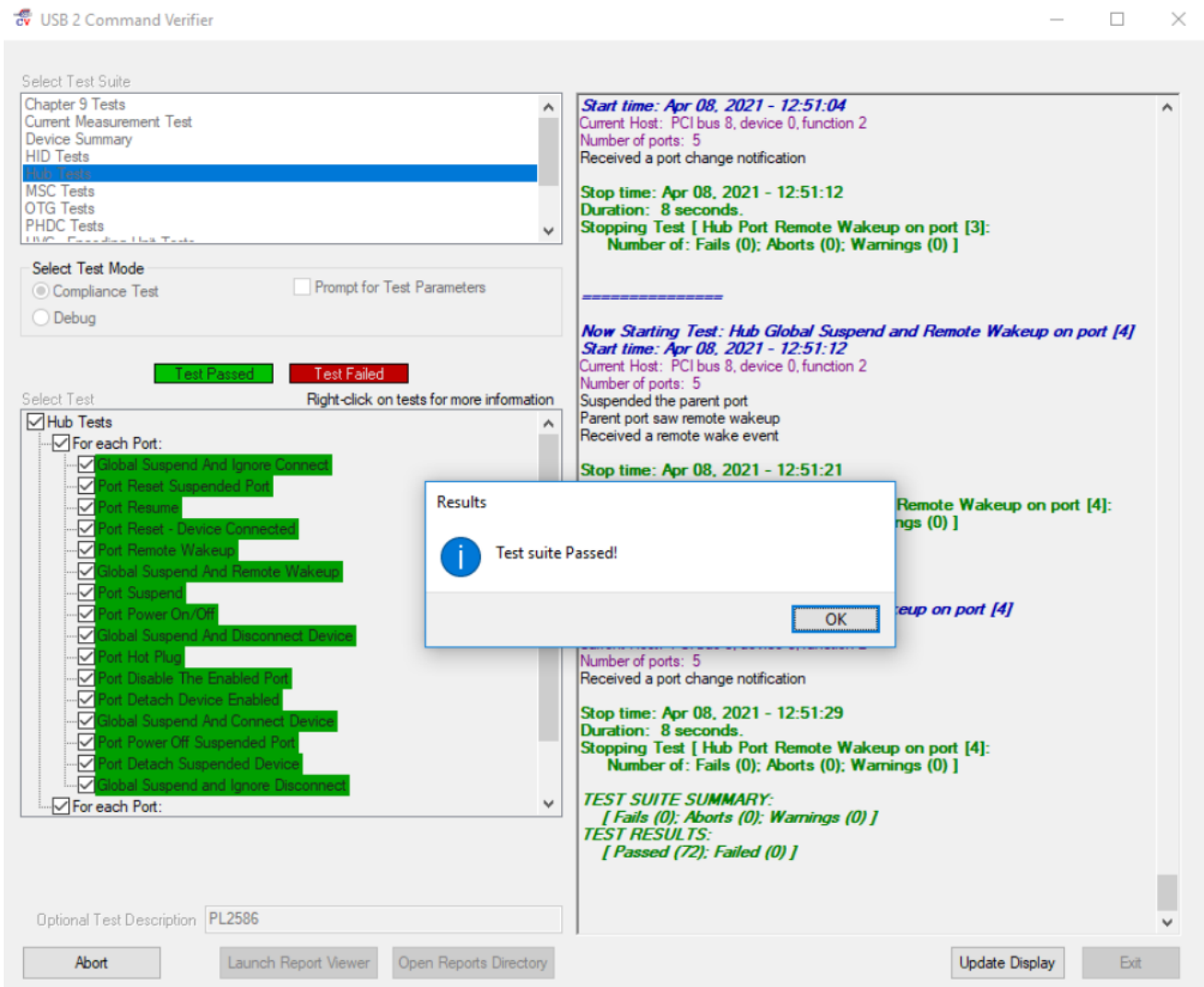

The screenshot displays the 'USB 2 Command Verifier' application window. The interface includes a 'Select Test Suite' dropdown menu with 'Hub Tests' selected. Below it, 'Select Test Mode' has 'Compliance Test' selected. A 'Select Test' list shows various hub tests, all of which are checked. A 'Results' dialog box is open in the center, displaying an information icon and the text 'Test suite Passed!' with an 'OK' button. The main window's right pane shows test logs for three different tests, including 'Hub Port Remote Wakeup on port [3]', 'Hub Global Suspend and Remote Wakeup on port [4]', and 'Hub Port Remote Wakeup on port [4]'. The logs show start and stop times, duration, and test results (Number of: Fails (0); Aborts (0); Warnings (0)). At the bottom, there are buttons for 'Abort', 'Launch Report Viewer', 'Open Reports Directory', 'Update Display', and 'Exit'. The 'Optional Test Description' field contains 'PL2586'.

Product Data Sheet PL2586 (USB 2.0 High Speed 4-Port Hub Controller)



USB 2 Command Verifier

Select Test Suite

- Chapter 9 Tests
- Current Measurement Test
- Device Summary
- HID Tests
- Hub Tests
- MSC Tests
- OTG Tests
- PHDC Tests

Select Test Mode

Compliance Test Prompt for Test Parameters

Debug

Test Passed Test Failed

Select Test Right-click on tests for more information

- Chapter 9 Tests
 - For each configuration:
 - Device Descriptor Test - Configured State
 - Device Descriptor Test - Addressed State
 - Interface Association Descriptor Test
 - BOS Descriptor Test - Addressed state
 - Config Descriptor Test - Configured State
 - Config Descriptor Test - Addressed State
 - Interface Descriptor Test
 - Endpoint Descriptor Test - Configured State
 - Endpoint Descriptor Test - Addressed State
 - Halt Endpoint Test
 - Set Configuration Test
 - Suspend/Resume Test
 - Remote Wakeup Test - Enabled
 - Remote Wakeup Test - Disabled
 - For each other speed configuration:
 - Other Speed Config Descriptor Test - Addressed State
 - Other Speed Interface Descriptor Test - Addressed State

Optional Test Description: PL2586

Abort Launch Report Viewer Open Reports Directory Update Display Exit

Start time: Apr 08, 2021 - 12:35:43
Testing Interface number : 0 Alternate setting : 0
Endpoint descriptor length : 7
Endpoint descriptor type : 5
Endpoint Type : Interrupt, Number : 1, Direction : IN
Endpoint descriptor bmAttributes : 3
Endpoint descriptor raw MaxPacketSize : 1
Endpoint descriptor interval : ff

Stop time: Apr 08, 2021 - 12:35:44
Duration: 1 second.
Stopping Test [Endpoint Descriptor Test (Configuration Index 0)
OtherSpeedConfiguration Index 0]:
Number of: Fails (0); Aborts (0); Warnings (0)]

Now Starting Test: Enumeration Test (repeat 150 times)
Start time: Apr 08, 2021 - 12:35:44
Device speed is High
Beginning enumeration test with 150 enumerations. This may take several minutes to complete.

.....	25 enumerations
.....	50 enumerations
.....	75 enumerations
.....	100 enumerations
.....	125 enumerations
.....	150 enumerations

Results

Test suite Passed!

OK

TEST SUITE SUMMARY:
[Fails (0); Aborts (0); Warnings (0)]
TEST RESULTS:
[Passed (23); Failed (0)]

9. Electrical Characteristics

9.1 Absolute Maximum Ratings

Symbol	Parameter	Min	Max	Unit
VBUS	5V Power Supply Voltage	-0.3	5.5	V
VDD33	3.3V Power Supply Voltage	-0.3	3.8	V
VDD12	1.2V Power Supply Voltage	-0.3	1.6	V
Ts	Storage Temperature	-40	150	°C

9.2 Operating Conditions

Symbol.	Parameter	Rating			Unit
		Min.	Typ.	Max.	
VBUS	5V Power Supply Voltage	3.0	5	5.5	V
VDD33	3.3V Power Supply Voltage	3.0	3.3	3.6	V
VDD12	1.2V Power Supply Voltage	1.08	1.2	1.32	V
T _A	Operating Temperature	-40	-	85	°C
T _J	Junction Temperature	-40	-	125	°C
θ _{Jc}	Thermal Characteristics SSOP28		22		°C/W
θ _{Jc}	Thermal Characteristics QFN24		20		°C/W

9.3 DC Characteristics

Symbol.	Parameter	Rating			Unit
		Min.	Typ.	Max.	
V _{IH}	High level input voltage	2.0	-	-	V
V _{IL}	Low level input voltage	-	-	0.8	V
V _{t-}	Schmitt-trigger negative to threshold voltage	-	-	1.6	V
V _{t+}	Schmitt-trigger positive to threshold voltage	1.8	-	-	V
V _{OH}	High level output voltage	2.5	-	-	V
V _{OL}	Low level output voltage	-	-	0.4	V
I _{OH}	High level output current	-	6	-	mA
I _{OL}	Low level output current (V _{OL} =0.4V)	-	6	-	mA

9.4 Power on Sequence

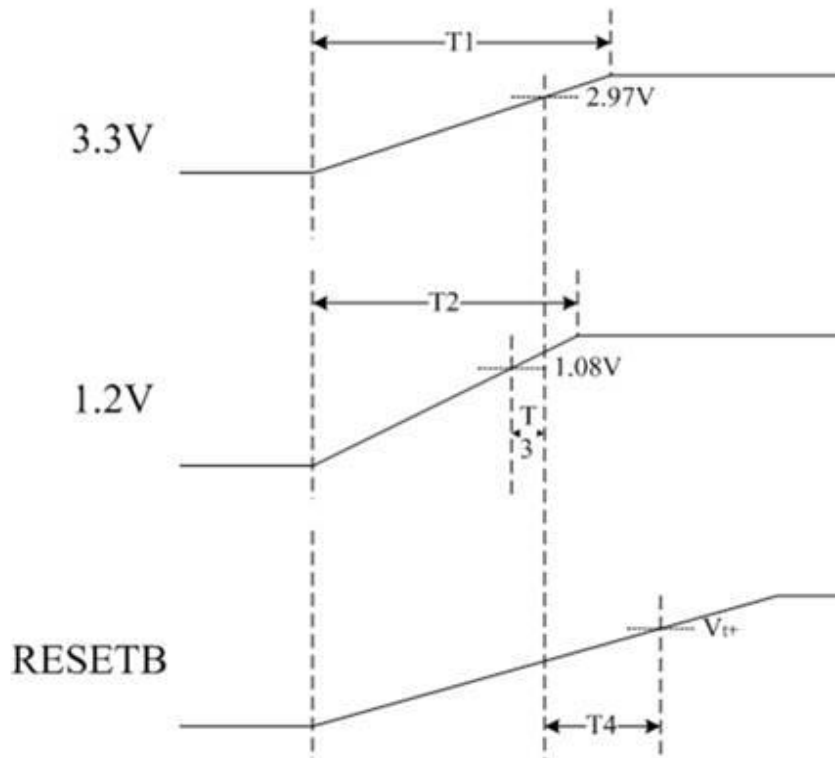

Reset Timing

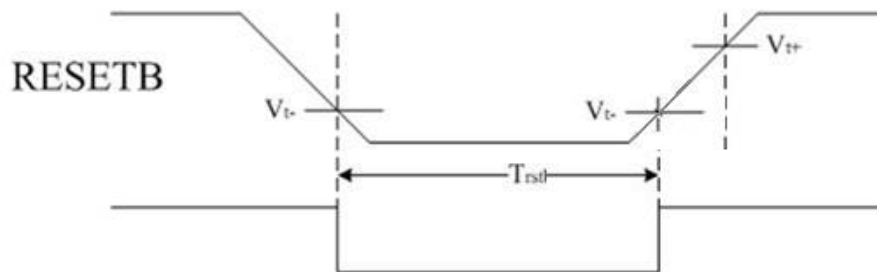

SYMBOL	MIN	TYP	MAX	UNIT
T1	-	70	-	us
T2	-	60	-	us
T3	-	12	-	us
T4	-	400	-	us
Trstb	2000	-	-	us

Note: For Vt+ and Vt-, refer to 9.3

10. Power consumption

10.1 Measurement with the total device consumption

PL2586 Power Consumption						
Symbol	Condition			Idle	R/W	Unit
	Active ports	Host	Device			
I _{cc}	4	H	H	55.3	135.6	mA
		H	F	53.0	58.6	mA
		H	L	49.3	49.6	mA
		F	H	45.7	54.9	mA
		F	F	52.7	58.4	mA
		F	L	46.8	47.1	mA
	3	H	H	53.6	122.1	mA
		H	F	51.2	55.3	mA
		H	L	48.5	48.8	mA
		F	H	45.2	51.8	mA
		F	F	51.0	55.2	mA
		F	L	46	49	mA
	2	H	H	51.8	98.1	mA
		H	F	49.5	52.1	mA
		H	L	47.8	48.1	mA
		F	H	44.7	49.8	mA
		F	F	49.4	52.0	mA
		F	L	45.2	45.5	mA
	1	H	H	50.1	64.7	mA
		H	F	47.9	49.2	mA
		H	L	47.2	47.5	mA
		F	H	44.4	48.3	mA
		F	F	47.6	49.0	mA
		F	L	44.6	44.9	mA
	No Active	H	n/a	0.538		mA
	No Active	F	n/a	0.631		mA
I _{susp}	Suspend			0.538		mA
F: Full-Speed, H: High-Speed						
H: USB Mass storage Device, Port1:SP 16G, Port2:Toshiba USB3.0 16G,						

Product Data Sheet

PL2586 (USB 2.0 High Speed 4-Port Hub Controller)



Port3:Supersonic 32G, Port4:Transcent USB3.1 32G
F : PL2303HXD, Baud Rate:115200bps
L : Low Speed Mouse

*** PL2586 provides the lowest IC power consumption on market.**

11. Package Outline

11.1 QFN24 Outline

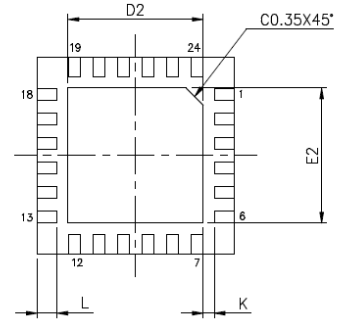
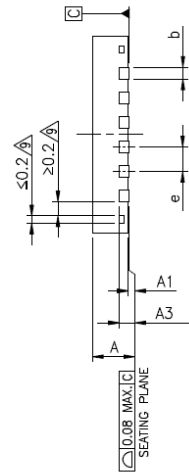
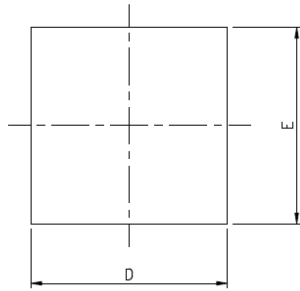

JEDEC OUTLINE	PACKAGE TYPE					
	MO-220			MO-220		
PKG CODE	WQFN(X424)			VQFN(Y424)		
SYMBOLS	MIN.	NOM.	MAX.	MIN.	NOM.	MAX.
A	0.70	0.75	0.80	0.80	0.85	0.90
A1	0.00	0.02	0.05	0.00	0.02	0.05
A3	0.20 REF.			0.20 REF.		
b	0.18	0.25	0.30	0.18	0.25	0.30
D	4.00 BSC			4.00 BSC		
E	4.00 BSC			4.00 BSC		
e	0.50 BSC			0.50 BSC		
K	0.20	—	—	0.20	—	—

PAD SIZE	E2			D2			L			LEAD FINISH		JEDEC CODE
	MIN.	NOM.	MAX.	MIN.	NOM.	MAX.	MIN.	NOM.	MAX.	Pure Tin	PPF	
112x112 ML	2.15	2.25	2.30	2.15	2.25	2.30	0.35	0.40	0.45	V	X	W(V)GGD-8
113x113 ML	2.50	2.60	2.65	2.50	2.60	2.65	0.35	0.40	0.45	X	V	W(V)GGD-6
114x114 ML	2.60	2.70	2.75	2.60	2.70	2.75	0.35	0.40	0.45	V	X	W(V)GGD-6
115x115 ML	2.40	2.50	2.55	2.40	2.50	2.55	0.35	0.40	0.45	V	X	W(V)GGD-8
120x120 ML	2.50	2.60	2.65	2.50	2.60	2.65	0.275	0.325	0.375	V	X	W(V)GGD-8

NOTES :

1. ALL DIMENSIONS ARE IN MILLIMETERS.
2. DIMENSION b APPLIES TO METALLIZED TERMINAL AND IS MEASURED BETWEEN 0.15mm AND 0.30mm FROM THE TERMINAL TIP. IF THE TERMINAL HAS THE OPTIONAL RADIUS ON THE OTHER END OF THE TERMINAL, THE DIMENSION b SHOULD NOT BE MEASURED IN THAT RADIUS AREA.
3. BILATERAL COPLANARITY ZONE APPLIES TO THE EXPOSED HEAT SINK SLUG AS WELL AS THE TERMINALS.

11.2 SSOP28 Outline

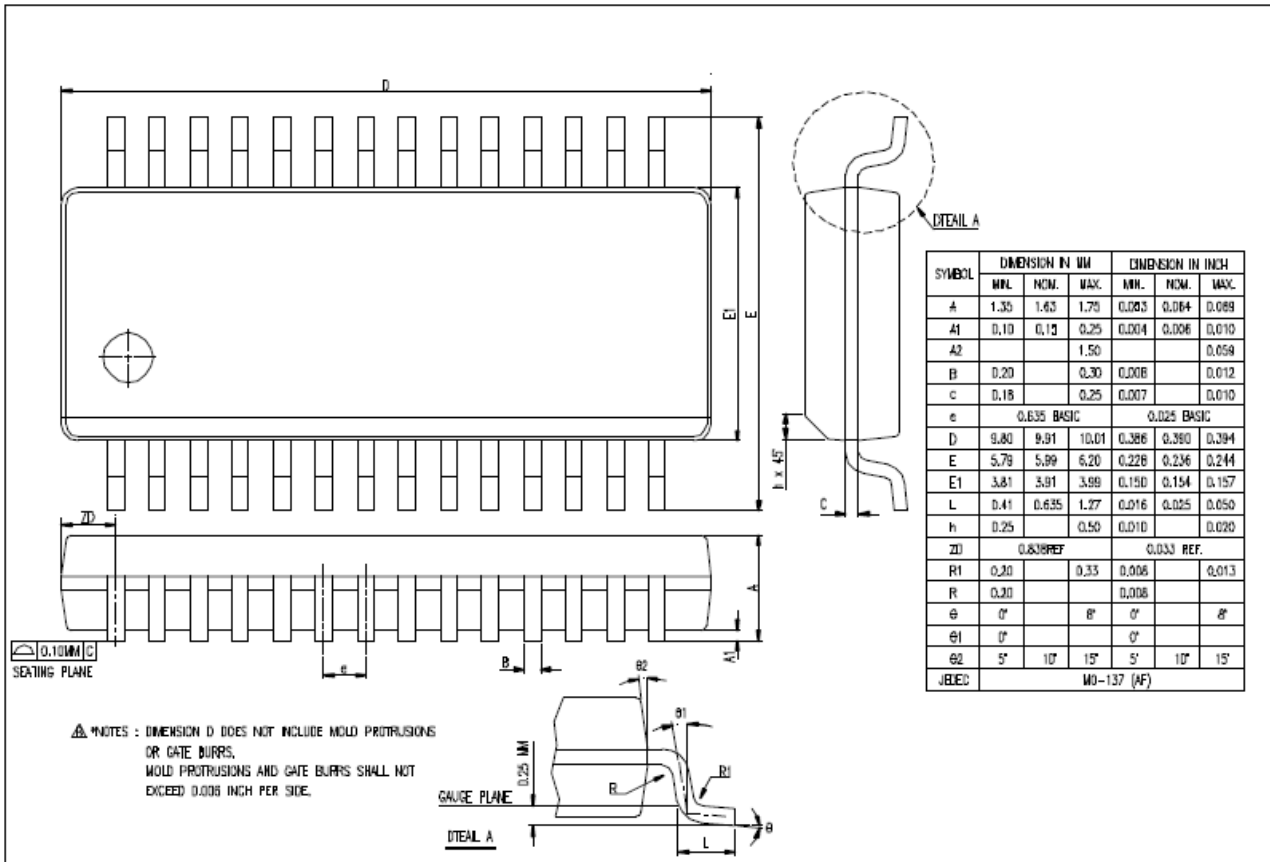

12. Package Information

12.1 Carrier Tape (SSOP-28)

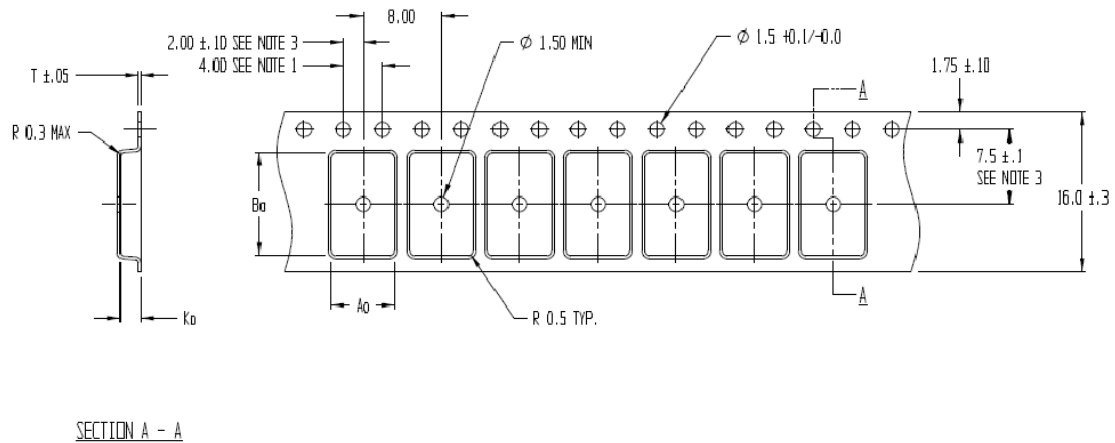

A₀ = 6.50
 B₀ = 10.30
 K₀ = 2.10

NOTES:

1. 10 SPROCKET HOLE PITCH CUMULATIVE TOLERANCE ±0.2
2. CAMBER IN COMPLIANCE WITH EIA 481
3. POCKET POSITION RELATIVE TO SPROCKET HOLE MEASURED AS TRUE POSITION OF POCKET, NOT POCKET HOLE

PART#	T	MATERIAL	DRAWING NO.
SDIC16-AC	0.30	PS+C	A0103-B9-14(2)
SDIC16-AD	0.30	PS+C	T108794BT

12.2 Carrier Tape (QFN24)

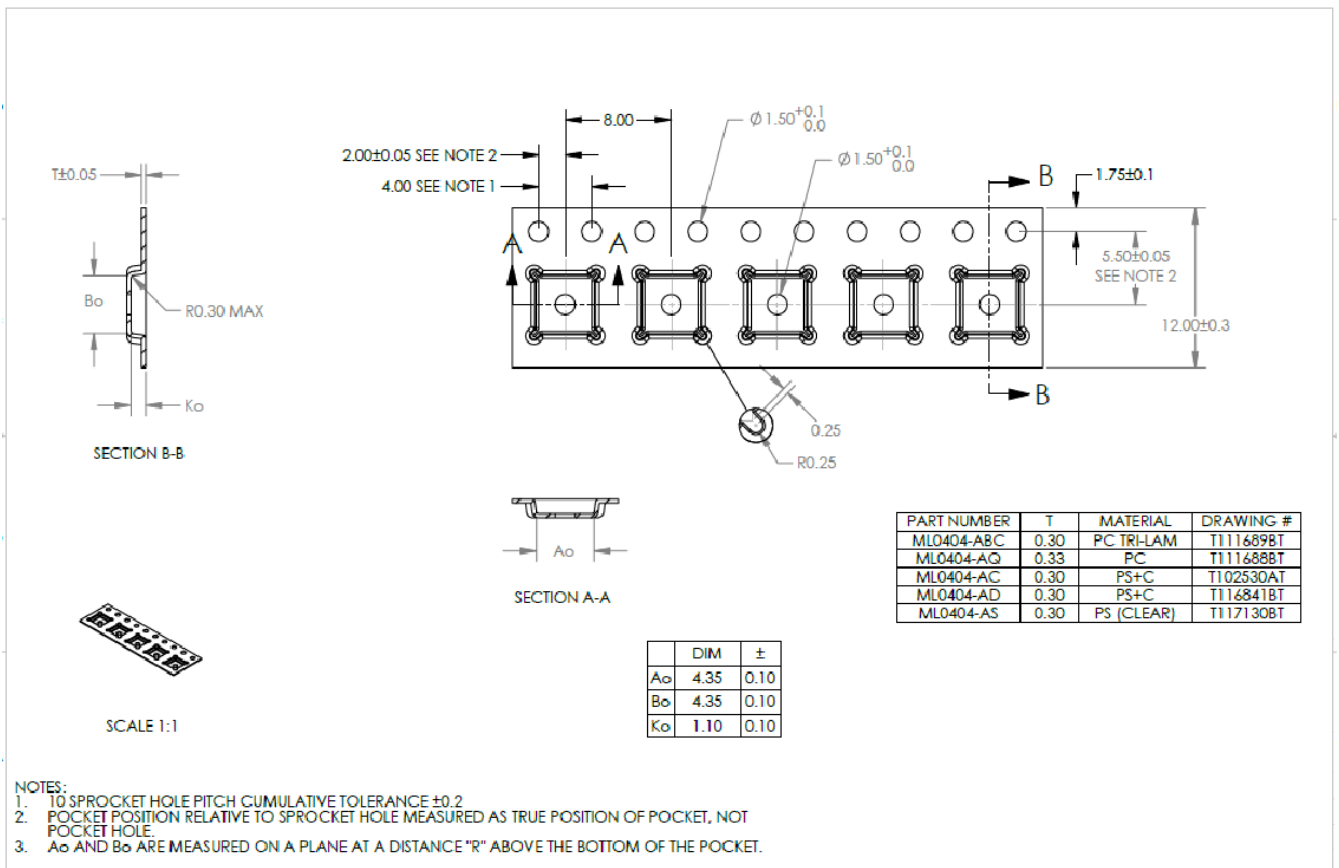

Disclaimer

All the information in this document is subject to change without prior notice. Prolific Technology Inc. does not make any representations or any warranties (implied or otherwise) regarding the accuracy and completeness of this document and shall in no event be liable for any loss of profit or any other commercial damage, including but not limited to special, incidental, consequential, or other damages.

Trademarks

The Prolific logo is a registered trademark of Prolific Technology Inc. All brand names and product names used in this document are trademarks or registered trademarks of their respective holders.

Copyrights

Copyright © 2021 - 2022 Prolific Technology Inc. All rights reserved.

No part of this document may be reproduced or transmitted in any form by any means without the express written permission of Prolific Technology Inc.

X-ON Electronics

Largest Supplier of Electrical and Electronic Components

Click to view similar products for [USB Interface IC](#) category:

Click to view products by [Prolific](#) manufacturer:

Other Similar products are found below :

[CY7C69356-48LTXC](#) [CYUSB2304-68LTXI](#) [USB2227-NU-11](#) [USB2251-NU-06](#) [CYPD2120-24LQXI](#) [CYUSB3014-BZXCT](#)
[CYWB0164BB-BZXI](#) [CYWB0224ABS-BZXI](#) [USB3321C-GL-TR](#) [LIF-UC120-SWG36ITR50](#) [CP2102NP1174GM](#) [DPO2039DABQ-13](#)
[UPD720115K8-611-BAK-A](#) [USB7216C-I/KDX](#) [UPD720115K8-711-BAK-A](#) [UPD720211K8-711-BAL-A](#) [PI2DPX1217XUAEX](#) [CYPD6127-48LQXIT](#) [CH340X](#) [CH343P](#) [SY6307BSCC](#) [SY6974QCC](#) [SY6818PLC](#) [FE1.1S-BQFN24B](#) [ME1502CM5G](#) [XPD920APS25](#)
[SY6288C30AAC](#) [WUSB3801Q-12/TR](#) [FT232RNL-REEL](#) [GL850G-HHY60](#) [FT232BL-JSM](#) [PL2303GC](#) [MA8621](#) [PL2303GT](#) [XPD319BP](#)
[XPD738BP](#) [XPD767DP45](#) [GL852G-HHY12](#) [TUSB213IRGYT](#) [TUSB213RGYT](#) [TUSB214RWBT](#) [TUSB4020BIPHRQ1](#) [USB2517I-JZX-TR](#) [USB3318-CP](#) [USB3343-CP](#) [USB3503T-I/ML](#) [USB4624I-1080HN](#) [CHY100D-TL](#) [STUSB1602AQTR](#) [TUSB214IRWBT](#)