

Power Metal Strip Resistors Surface Mount

PMS45 Series

Features

- Molded high temperature encapsulation.
- Improved thermal management incorporated into design.
- All welded construction of the Power Metal Strip resistors are ideal for all types of current sensing, voltage division and pulse applications.
- Sulfur resistance by construction that is unaffected by high sulfur environments.
- Solid metal nickel-chrome or manganese- copper alloy resistive element with low TCR (< 20 ppm/°C)
- Very low inductance 0.5 nH to 10 nH.
- Low thermal EMF (< 5 $\mu\text{V}/^\circ\text{C}$)
- AEC-Q200 qualified available.

Part number

PMS 45 F 5P0 R120
【1】 【2】 【3】 【4】 【5】

【1】 Series Name: Power Metal Strip Resistors.

【2】 Chip Size: 45: 4527.

【3】 Resistance Precision: F: $\pm 1\%$.

【4】 Power Rating: 5P0: 5W.

【5】 Resistance Code: R080:80m Ω , R120:120m Ω , 8M20:8.2m Ω .

Electrical Characteristics

Size	Power Rating at 70°C (W)	Resistance Range (m Ω)* $\pm 1\%$	Element TCR (ppm/°C)	Operation Temperature Range	Product temperature coefficient (ppm/°C)	Insulation resistance
4527	5	5~120	<20	-55°C~+170°C	± 75 : 10m Ω \leq R \leq 120m Ω ± 110 : 5m Ω \leq R < 10m Ω	> 10 ⁹

“*” : Other values may be available, contact factory

Note:

- 1) $I_r = (P/R)^{1/2}$ R: Resistance Value I_r : Rating Current P: Rating Power;
- 2) Product temperature coefficient: Includes the TCR effects of the resistor element and the copper terminal.

Physical Dimensions

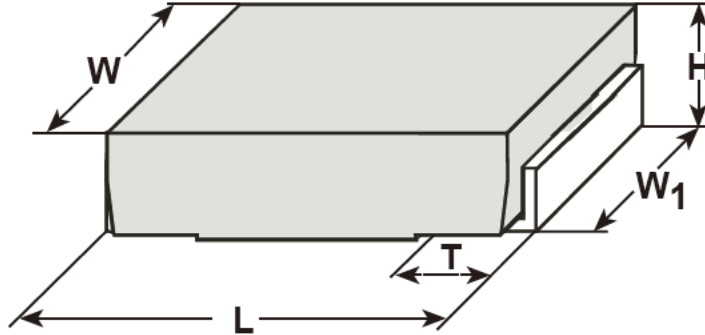

Unit: mm

Type	Resistance (mΩ)	L	H	T	W	W1
PMS45	5~120	11.60±0.60	2.50±0.30	2.80±0.50	7.00±0.3	5.46±0.20

Recommended Solder Pad Layout

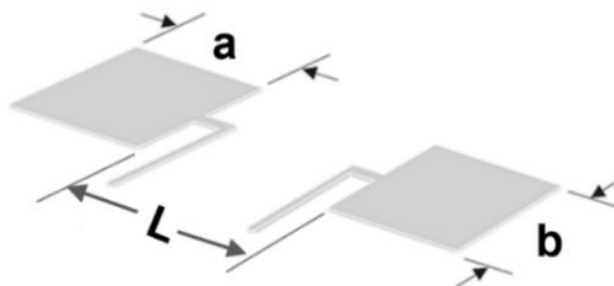

Unit: mm

Type	a	b	L
PMS45	3.94	5.84	5.21

Marking Instructions

PMS45 is marked with four digit, We have two different ways of marking :

a. "R" designates the decimal location in ohms,

e. g. 80mΩ: R080; 120mΩ: R120

b. "m" designates the decimal location in milliohms,

e. g. 8.2mΩ: 8m20

Power Derating Curve

For resistors operated in ambient temperatures 70°C, power rating shall be derated in according with the curve below:

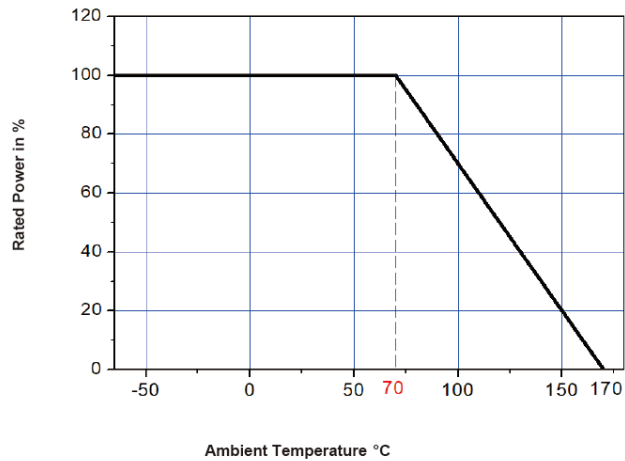

Recommended Solder Curve

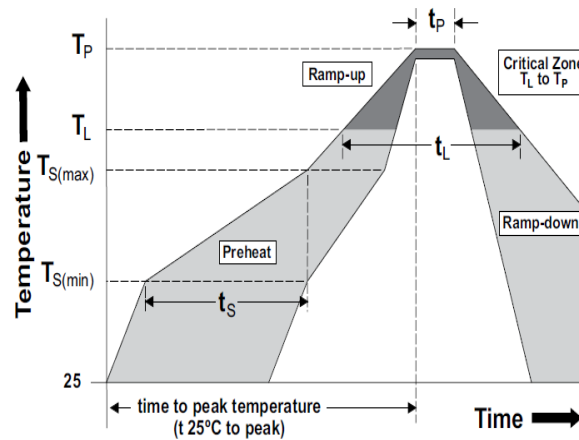

Reflow Condition		Pb – Free assembly
Pre heat	- Temperature Min ($T_{S(min)}$)	150°C
	- Temperature Max ($T_{S(max)}$)	200°C
	- Time (Min to Max) (t_s)	60 – 120 secs
Average ramp up rate (Liquidus Temp (T_L) to peak)		5°C/second max
$T_{S(max)}$ to T_L - Ramp-up Rate		5°C/second max
Reflow	- Temperature (T_L) (Liquidus)	217°C
	- Time (t_L)	60 – 150 seconds
Peak Temperature (T_P)		260°C
Time within 5°C of actual peak Temperature (t_p)		20 – 40 seconds
Ramp-down Rate		5°C/second max
Time 25°C to peak Temperature (T_P)		8 minutes Max.
Wave Soldering		260°C, 10 seconds max.
Hand Soldering		350°C, 5 seconds max.

Product Characteristics

Item	Test condition/ Methods	Limited	Standard
Resistance	Measuring resistance value at room temperature 25°C±5°C	Refer to Spec	IEC60115-1 4.5
External Visual	There is no need for electrical test, check the device structure, identification and process quality, and electrical test is not required.	Refer to Spec	MIL-STD-883 Method 2009
Physical Dimension	Verify physical dimensions according to device specifications.	Refer to Spec	JESD22-B100
Temperature Coefficient of Resistance	TCR (ppm/°C) = (R2-R1/R1*(T2-T1))X10 ⁶ R1: resistance value measured at room temperature (Ω) R2: Resistance measured at 125 °C (Ω) T1: room temperature (°C) T2: 125°C	Refer to Spec	IEC 60115-1 4.8
Short Time Overload	Apply 5 times rated power for 5 seconds, and measure the resistance change after standing for 24 hours.	≤±2%	IEC 60115-1 4.13
High Temperature Storage	170°C for 1000hours, No power.	≤±1%	MIL-STD-202 Method 108
Temperature Cycling	Pre-treatments with 3X reflow, -55°C (15min)/+150°C (15min), 1000 cycles, transition time less than 1 minute	≤±0.5%	JESD22-A104
Bias Humidity	Pre-treatments with 3X reflow, +85°C, 85% RH, 10% of operating power, 1000hours	≤±0.5%	MIL-STD-202 Method103
Operational life	Pre-treatments with 3X reflow, 70°C ± 2°C, 1000 hours, at rated power 1.5 hours "ON", 0.5 hours "OFF".	≤±2%	MIL-STD-202 Method 108
Mechanical shock	Condition C ,100 g's ,6 msec, 3 mutually perpendicular axes, in 6 directions, three impacts each for a total of 18 times 18 shocks.	≤±0.5%	MIL-STD-202 Method 213
Vibration	5g's for 20 minutes 12 cycles each of 3 orientations. Test from 10 Hz - 2000 Hz	≤±0.5%	MIL-STD-202 Method 204
Resistance to Soldering Heat	260±5°C, 10s±1s	≤±0.5%	MIL-STD-202 Method 210
ESD	Direct Contact Discharge 8KV, Air Discharge 25KV	≤±1%	AEC-Q200-002
Solderability	245±5°C time: 5sec+0/-0.5sec.	≥95%	J-STD-002
	260±5°C time: 30sec+5sec	≥95%	J-STD-002
Bending	Bend the board (D) x = 2 mm minimum, the duration of the applied forces shall be 60 (+ 5) Sec.	≤±1%	AEC-Q200-005

Packaging

Tape Dimensions

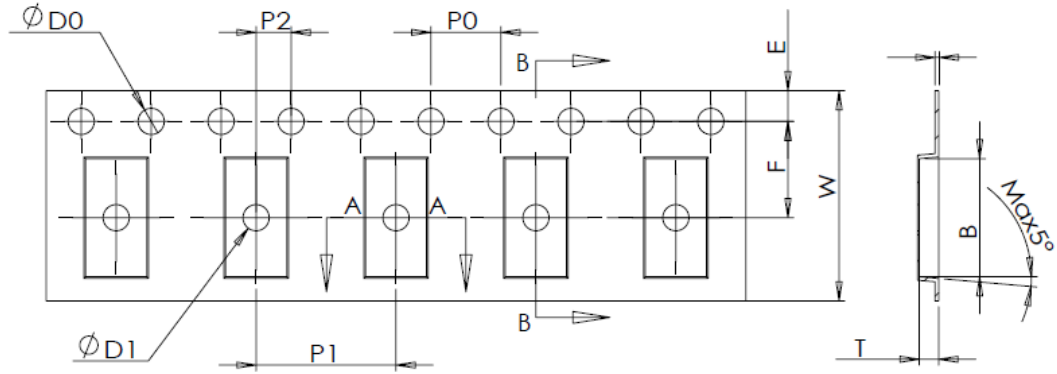

Unit: mm

Series	Type	A	B	D0	E	F	φD1
4527	5-120mΩ	7.28±0.10	11.86±0.10	1.50±0.10	1.75±0.10	11.50±0.10	1.50±0.10
Series	Type	W	P0	P1	P2	T	
4527	5-120mΩ	24.0±0.30	4.00±0.10	12.0±0.10	2.00±0.10	2.71±0.10	

Reel Dimensions

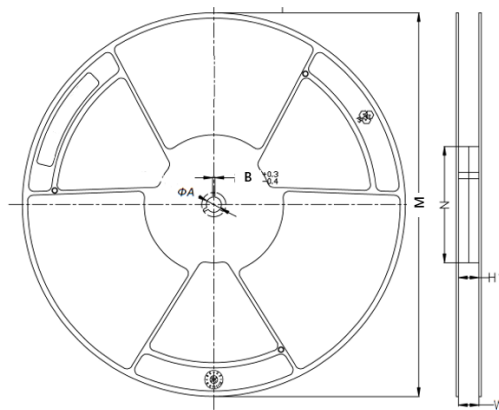

Unit: mm

Series	Type	W (mm)	M (mm)	φA (mm)	N (mm)	H1 (mm)	H2 (mm)
4527	13' reel	24.4±1.0	330.0±2.0	13.4±0.5	100.0±0.2	24.4±1.0	28.6±1.0

Quantity of Package

Type	Quantity (pcs)
4527	1500

Storage

1. The temperature condition must be controlled at $25\pm 5^{\circ}\text{C}$, The R.H. must be controlled at $60\pm 15\%$ Store in accordance with this requirement, and the validity period is two years after the date of manufacture.
2. Please avoid the mentioned harsh environment below when storing to ensure product performance and its' weldability. Places exposed to sea breeze or other corrosive gas, such as Cl_2 , H_2S , NH_3 , SO_2 and NO_2 .
3. When the product is moved and stored, please ensure the correct orientation of the box. Do not drop or squeeze the box. Otherwise, the electrode or the body of the product may be damaged.

X-ON Electronics

Largest Supplier of Electrical and Electronic Components

Click to view similar products for [Current Sense Resistors - SMD category](#):

Click to view products by [PROSEMI manufacturer](#):

Other Similar products are found below :

[CRL0603-FW-R700ELF](#) [PFS35-200RF1](#) [CD2015FC-0.10-1%](#) [PR2512FKF7W0R004L](#) [RC1005F124CS](#) [CSNL2512FT5L00](#)

[RL73K3AR56JTDF](#) [RL7520WT-R001-F](#) [RL7520WT-R020-F](#) [LRC-LR2512LF-01-R820J](#) [65709-330](#) [SP1R12J](#) [RL7520WT-R039-G](#)

[RL7520WT-R002-F](#) [RL7520WT-R005-F](#) [KRL1632E-C-R200-F-T5](#) [KRL1632E-C-R200-F-T1](#) [Y14880R02000B9R](#) [RLP73M2AR075FTDF](#)

[SR731ERTTP5R10F](#) [SR731ERTTP100J](#) [SR731ERTTP6R80F](#) [SR731ERTTP3R9J](#) [SR731ERTTP8R2J](#) [SR731ERTTP2R0J](#)

[SR731ERTTP4R7J](#) [SR731ERTTP9R1J](#) [SR731ERTTP1R0J](#) [SR731ERTTP2R2J](#) [SR731ERTTP5R1J](#) [SR731ERTTP6R8J](#) [SR731ERTTP9R10F](#)

[FCSL64R007JER](#) [73L4R10G](#) [73L4R75G](#) [73L4R33G](#) [73M1R051F](#) [73WL4R020J](#) [73L2R68J](#) [73L2R22J](#) [73L2R33J](#) [CC1512FC-0.015-5%](#)

[ULRG2-2512-R0075-F-LF-SLT](#) [KDV08DR220ET](#) [KDV12DR240ET](#) [SLN3TTED80L6F](#) [JW104X15X4](#) [JW105X19X5](#) [HVR06FTEV2403](#)

[JW104X5X4](#)