

Features

- Ultra low quiescent current: 2μA
- Low voltage drop
- Low temperature coefficient
- Low power consumption
- High input voltage (up to 15V)
- Output voltage accuracy: tolerance ±2%
- Output current:250mA(Typ.)
- TO92, SOT89, SOT23-3andSOT23 package

Applications

- Battery-powered equipment
- Communication equipment
- Audio/Video equipment

General Description

The SR73XXMseries is a set of three-terminal low technology ensures low voltage drop and low power high voltage regulators implemented in quiescent current. Although designed primarily as CMOS technology. They allow input voltages as fixed voltage regulators, these devices can be high as15V. They are available with several fixed used with external components to obtain variable output voltages ranging from 2.5V to 5.0V. CMOS voltages and currents.

Selection Table

Part No.	Output Voltage	Package	Marking
SR7325MXX	2.5V	TO92 SOT89 SOT23-3 SOT23	73XX-A(for TO92) 73XX-A(for SOT89) 3XX(for SOT23-3) 3XX(for SOT23)
SR7328MXX	2.8V		
SR7330MXX	3.0V		
SR7333MXX	3.3V		
SR7336MXX	3.6V		
SR7340MXX	4.0V		
SR7344MXX	4.4V		
SR7350MXX	5.0V		

Note:"XX" stands for output voltages.

TO92 & SOT89 packages will add a “#” mark at the end of the marking.

Order Information

SR73①②③④⑤

Designator	Symbol	Description
①②	Integer	Output Voltage(2.5~5.0V)
③	M	Standard
④	T	Package:TO-92
	P	Package: SOT89-3
	M	Package: SOT23-3
	N	Package: SOT23
⑤	R	RoHS / Pb Free
	G	Halogen Free

Block Diagram

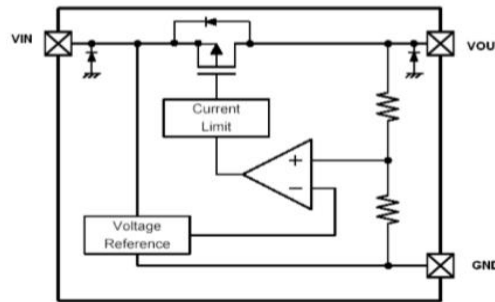

Pin Assignment

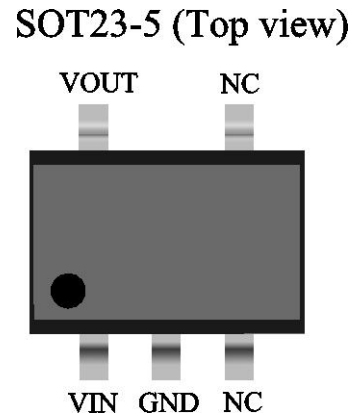
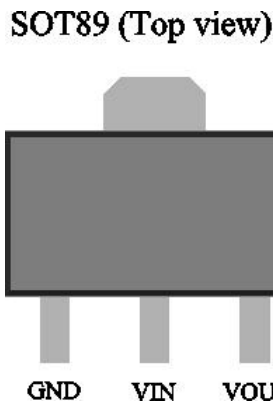
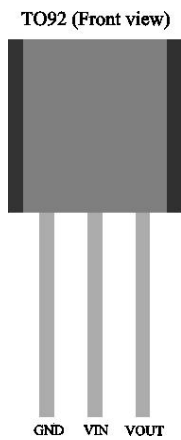

Absolute Maximum Ratings

Supply Voltage-0.3V to 18V Storage Temperature-50°C to 125°C
 Operating Temperature-30°C to 85°C

Note: These are stress ratings only. Stresses exceeding the range specified under “Absolute Maximum Ratings” may cause substantial damage to the device. Functional operation of this device at other conditions beyond those listed in the specification is not implied and prolonged exposure to extreme conditions may affect device reliability.

Thermal Information

Symbol	Parameter	Package	Max.	Unit
θ_{JA}	Thermal Resistance (Junction to Ambient) (Assume no ambient airflow, no heat sink)	SOT23-3	500	°C/W
		SOT89	200	W
		TO-92	200	°C/W
P_D	Power Dissipation	SOT23-3	0.20	W
		SOT89	0.50	°C/W
		TO-92	0.50	W

Note: P_D is measured at $T_a = 25^\circ\text{C}$

Electrical Characteristics
SR7325Mxx, +2.5V Output Type

Symbol	Parameters	V _{IN}	Conditions	Min	Typ.	Max	Unit
V _{OUT}	Output Voltage	4.5V	I _{OUT} =40mA	2.45	2.5	2.55	V
I _{OUT}	Output Current	4.5V	-	-	250	-	mA
ΔV _{OUT}	Load Regulation	4.5V	1mA ≤ I _{OUT} ≤ 60mA	-	45	90	mV
V _{DIF}	Voltage Drop	-	I _{OUT} =40mA, ΔV _{OUT} =2%	-	100	-	mV
I _{SS}	Current Consumption	4.5V	No load	-	2.0	3.0	μA
$\frac{\Delta V_{OUT}}{\Delta V_{IN} \times V_{OUT}}$	Line Regulation	-	3.5V ≤ V _{IN} ≤ 12V I _{OUT} =40mA	-	0.2	-	%/V
V _{IN}	Input Voltage	-	-	-	-	15	V
$\frac{\Delta V_{OUT}}{\Delta T_A}$	Temperature Coefficient	4.5V	I _{OUT} =40mA -40 °C < T _a < 85 °C	-	±0.5	-	mV/°C

SR7328Mxx, +2.8V Output Type

Symbol	Parameters	V _{IN}	Conditions	Min	Typ.	Max	Unit
V _{OUT}	Output Voltage	4.8V	I _{OUT} =10mA	2.744	2.8	2.856	V
I _{OUT}	Output Current	4.8V	-	-	250	-	mA
ΔV _{OUT}	Load Regulation	4.8V	1mA ≤ I _{OUT} ≤ 60mA	-	45	90	mV
V _{DIF}	Voltage Drop	-	I _{OUT} =40mA, ΔV _{OUT} =2%	-	100	-	mV
I _{SS}	Current Consumption	4.8V	No load	-	2.0	3.0	μA
$\frac{\Delta V_{OUT}}{\Delta V_{IN} \times V_{OUT}}$	Line Regulation	-	3.8V ≤ V _{IN} ≤ 12V I _{OUT} =40mA	-	0.2	-	%/V
V _{IN}	Input Voltage	-	-	-	-	15	V
$\frac{\Delta V_{OUT}}{\Delta T_A}$	Temperature Coefficient	4.8V	I _{OUT} =10mA -40 °C < T _a < 85 °C	-	±0.5	-	mV/°C

SR7330Mxx,+3.0V O

Symbol	Parameters	V _{IN}	Conditions	Min	Typ.	Max	Unit
V _{OUT}	Output Voltage	5V	I _{OUT} =40mA	2.94	3.0	3.06	V
I _{OUT}	Output Current	5V	-	-	250	-	mA
ΔV _{OUT}	Load Regulation	5V	1mA≤I _{OUT} ≤80mA	-	45	90	mV
V _{DIF}	Voltage Drop	-	I _{OUT} =40mA,ΔV _{OUT} =2%	-	100	-	mV
I _{SS}	Current Consumption	5V	No load	-	2.0	3.0	μA
$\frac{\Delta V_{OUT}}{\Delta V_{IN} \times V_{OUT}}$	Line Regulation	-	4V≤V _{IN} ≤12V I _{OUT} =40mA	-	0.2	-	%/V
V _{IN}	Input Voltage	-	-	-	-	15	V
$\frac{\Delta V_{OUT}}{\Delta TA}$	Temperature Coefficient	5V	I _{OUT} =40mA -40°C<Ta<85°C	-	±0.5	-	mV/°C

SR7333Mxx,+3.3V O

Symbol	Parameters	V _{IN}	Conditions	Min	Typ.	Max	Unit
V _{OUT}	Output Voltage	5.3V	I _{OUT} =40mA	3.234	3.3	3.366	V
I _{OUT}	Output Current	5.3V	-	-	250	-	mA
ΔV _{OUT}	Load Regulation	5.3V	1mA≤I _{OUT} ≤80mA	-	45	90	mV
V _{DIF}	Voltage Drop	-	I _{OUT} =10mA,ΔV _{OUT} =2%	-	100	-	mV
I _{SS}	Current Consumption	5.3V	No load	-	2.0	3.0	μA
$\frac{\Delta V_{OUT}}{\Delta V_{IN} \times V_{OUT}}$	Line Regulation	-	4.3V≤V _{IN} ≤12V I _{OUT} =40mA	-	0.2	-	%/V
V _{IN}	Input Voltage	-	-	-	-	15	V
$\frac{\Delta V_{OUT}}{\Delta TA}$	Temperature Coefficient	5.3V	I _{OUT} =40mA -40°C<Ta<85°C	-	±0.5	-	mV/°C

SR7336Mxx,+3.6V O

Symbol	Parameters	V _{IN}	Conditions	Min	Typ.	Max	Unit
V _{OUT}	Output Voltage	5.6V	I _{OUT} =40mA	3.528	3.6	3.372	V
I _{OUT}	Output Current	5.6V	-	-	250	-	mA
ΔV _{OUT}	Load Regulation	5.6V	1mA≤I _{OUT} ≤80mA	-	45	90	mV
V _{DIF}	Voltage Drop	-	I _{OUT} =10mA,ΔV _{OUT} =2%	-	80	-	mV
I _{SS}	Current Consumption	5.6V	No load	-	2.0	3.0	μA
$\frac{\Delta V_{OUT}}{\Delta V_{IN} \times V_{OUT}}$	Line Regulation	-	4.6V≤V _{IN} ≤12V I _{OUT} =40mA	-	0.2	-	%/V
V _{IN}	Input Voltage	-	-	-	-	15	V
$\frac{\Delta V_{OUT}}{\Delta T_A}$	Temperature Coefficient	5.6V	I _{OUT} =40mA -40°C<T _a <85°C	-	±0.5	-	mV/°C

SR7340Mxx,+4.0V O

Symbol	Parameters	V _{IN}	Conditions	Min	Typ.	Max	Unit
V _{OUT}	Output Voltage	6.0V	I _{OUT} =40mA	3.920	4.0	4.080	V
I _{OUT}	Output Current	6.0V	-	-	250	-	mA
ΔV _{OUT}	Load Regulation	6.0V	1mA≤I _{OUT} ≤80mA	-	45	90	mV
V _{DIF}	Voltage Drop	-	I _{OUT} =10mA,ΔV _{OUT} =2%	-	80	-	mV
I _{SS}	Current Consumption	6.0V	No load	-	2.0	3.0	μA
$\frac{\Delta V_{OUT}}{\Delta V_{IN} \times V_{OUT}}$	Line Regulation	-	5V≤V _{IN} ≤12V I _{OUT} =40mA	-	0.2	-	%/V
V _{IN}	Input Voltage	-	-	-	-	15	V
$\frac{\Delta V_{OUT}}{\Delta T_A}$	Temperature Coefficient	6.0V	I _{OUT} =40mA -40°C<T _a <85°C	-	±0.5	-	mV/°C

SR7344Mxx,+4.4V O

Symbol	Parameters	V _{IN}	Conditions	Min	Typ.	Max	Unit
V _{OUT}	Output Voltage	6.4V	I _{OUT} =40mA	4.312	4.4	4.488	V
I _{OUT}	Output Current	6.4V	-	-	250	-	mA
ΔV _{OUT}	Load Regulation	6.4V	1mA≤I _{OUT} ≤80mA	-	45	90	mV
V _{DIF}	Voltage Drop	-	I _{OUT} =40mA,ΔV _{OUT} =2%	-	80	-	mV
I _{SS}	Current Consumption	6.4V	No load	-	2.0	3.0	μA
$\frac{\Delta V_{OUT}}{\Delta V_{IN} \times V_{OUT}}$	Line Regulation	-	5.4V≤V _{IN} ≤12V I _{OUT} =40mA	-	0.2	-	%/V
V _{IN}	Input Voltage	-	-	-	-	15	V
$\frac{\Delta V_{OUT}}{\Delta T_A}$	Temperature Coefficient	6.4V	I _{OUT} =40mA -40°C<T _a <85°C	-	±0.5	-	mV/°C

SR7350Mxx,+5.0V O

Symbol	Parameters	V _{IN}	Conditions	Min	Typ.	Max	Unit
V _{OUT}	Output Voltage	6.4V	I _{OUT} =40mA	4.9	5.0	5.1	V
I _{OUT}	Output Current	6.4V	-	-	250	-	mA
ΔV _{OUT}	Load Regulation	6.4V	1mA≤I _{OUT} ≤80mA	-	45	90	mV
V _{DIF}	Voltage Drop	-	I _{OUT} =40mA,ΔV _{OUT} =2%	-	80	-	mV
I _{SS}	Current Consumption	6.4V	No load	-	2.0	3.0	μA
$\frac{\Delta V_{OUT}}{\Delta V_{IN} \times V_{OUT}}$	Line Regulation	-	6.0V≤V _{IN} ≤12V I _{OUT} =40mA	-	0.2	-	%/V
V _{IN}	Input Voltage	-	-	-	-	15	V
$\frac{\Delta V_{OUT}}{\Delta T_A}$	Temperature Coefficient	6.4V	I _{OUT} =40mA -40°C<T _a <85°C	-	±0.5	-	mV/°C

Typical Performance Characteristics

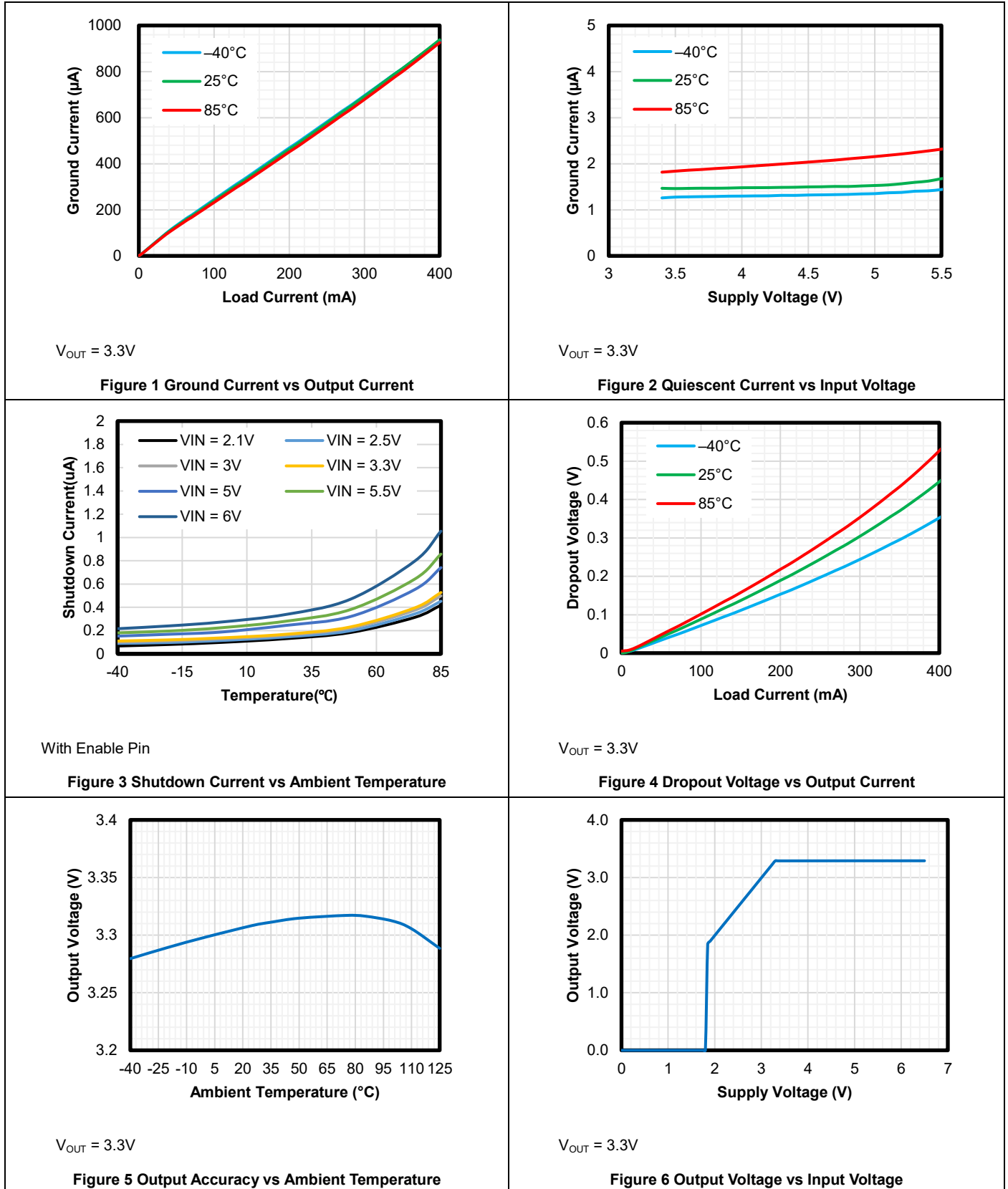

Typical Performance Characteristics

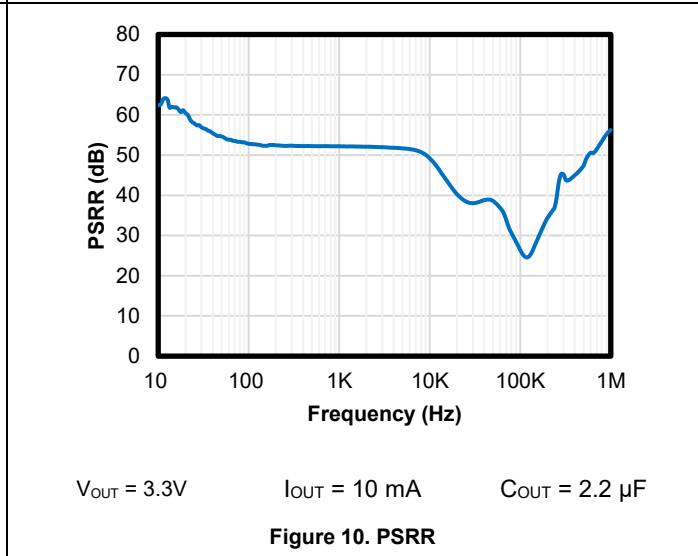
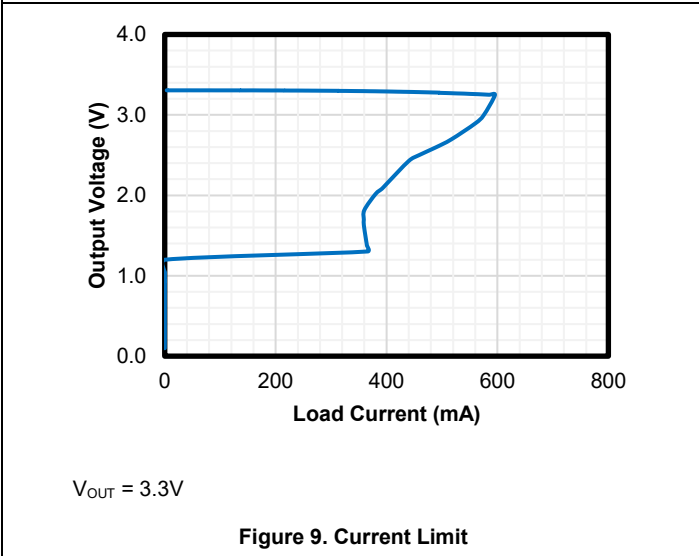
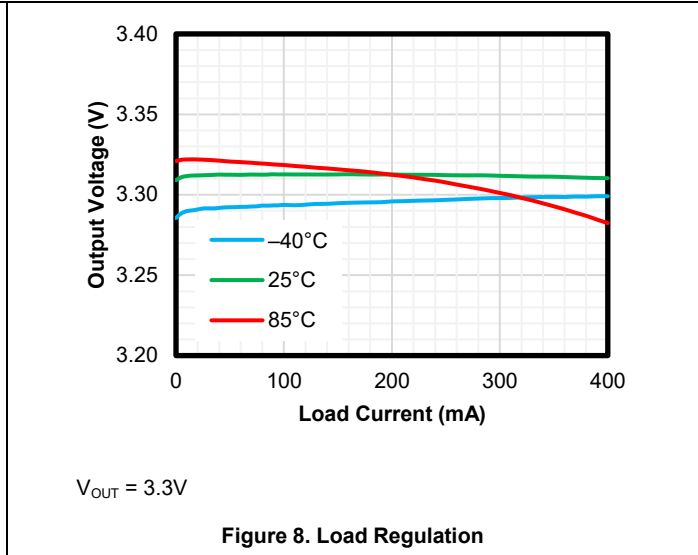
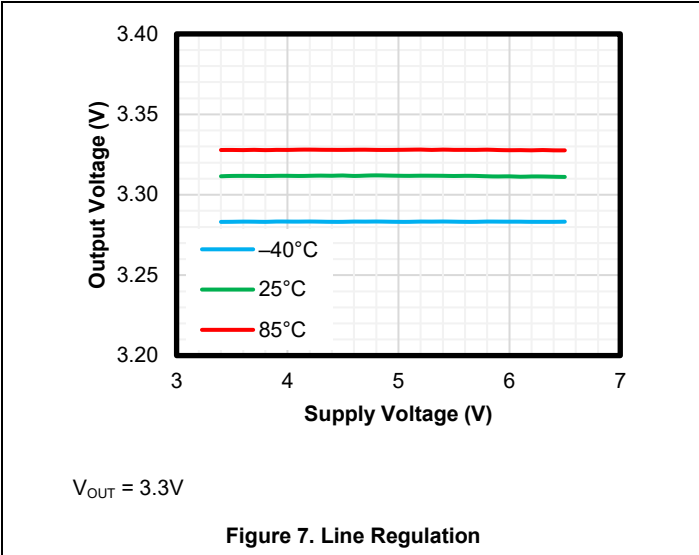

(5) MAX Output Current Vs. Input Voltage

7330MPR

Input Voltage	Max Output Current
5V	250mA
9V	200mA
12V	150mA
15V	100mA

7333MPR

Input Voltage	Max Output Current
5.3V	250mA
9V	200mA
12V	150mA
15V	100mA

7350MPR

Input Voltage	Max Output Current
7V	250mA
9V	200mA
12V	150mA
15V	100mA

Application Circuits

Basic Circuits

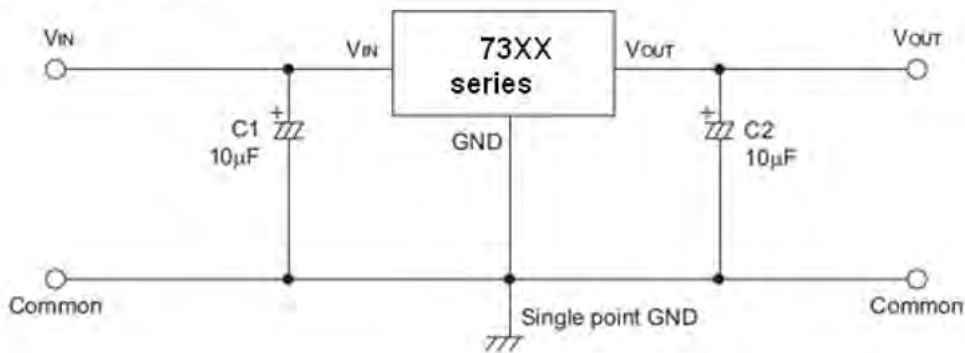

Package Information
3-pin TO-92 Outline Dimensions

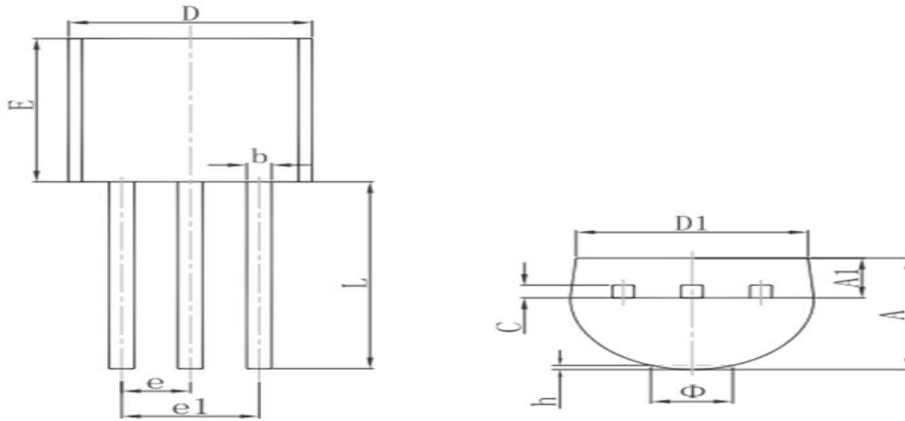

3-pin SOT89 Outline Dimensions

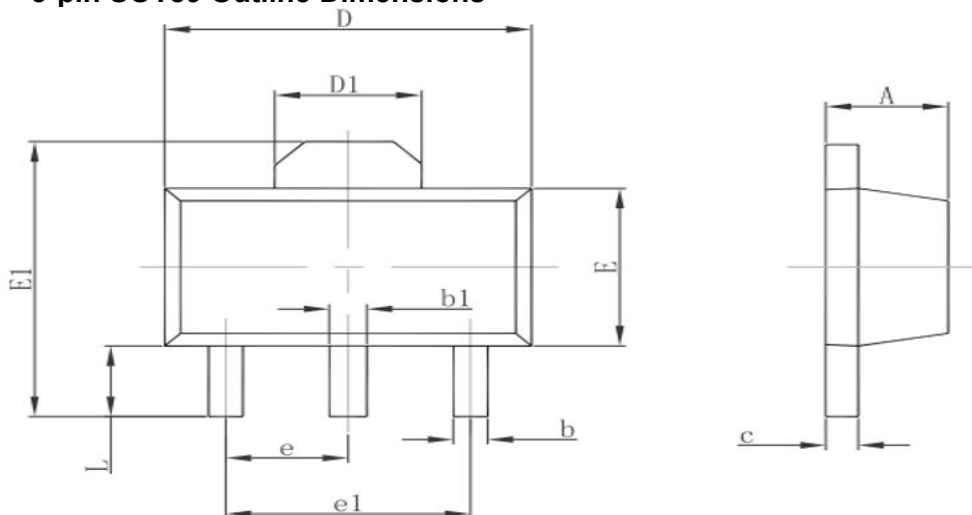

Symbol	Dimensions In Millimeters		Dimensions In Inches	
	Min.	Max.	Min.	Max.
A	1.400	1.600	0.055	0.063
b	0.320	0.520	0.013	0.020
b1	0.400	0.580	0.016	0.023
c	0.350	0.440	0.014	0.017
D	4.400	4.600	0.173	0.181
D1	1.550 REF.		0.061 REF.	
E	2.300	2.600	0.091	0.102
E1	3.940	4.250	0.155	0.167
e	1.500 TYP.		0.060 TYP.	
e1	3.000 TYP.		0.118 TYP.	
L	0.900	1.200	0.035	0.047

3-pin SOT23-3 Outline Dimensions

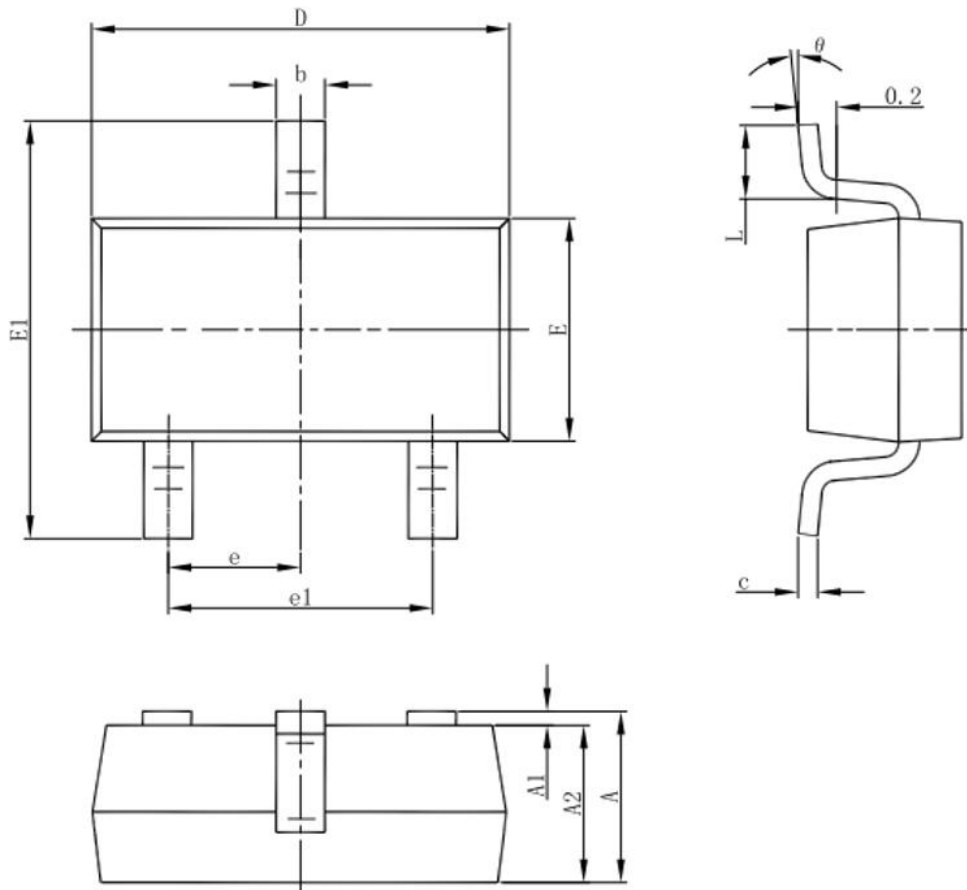

Symbol	Dimensions In Millimeters		Dimensions In Inches	
	Min	Max	Min	Max
A	1.050	1.250	0.041	0.049
A1	0.000	0.100	0.000	0.004
A2	1.050	1.150	0.041	0.045
b	0.300	0.500	0.012	0.020
c	0.100	0.200	0.004	0.008
D	2.820	3.020	0.111	0.119
E	1.500	1.700	0.059	0.067
E1	2.650	2.950	0.104	0.116
e	0.950(BSC)		0.037(BSC)	
e1	1.800	2.000	0.071	0.079
L	0.300	0.600	0.012	0.024
θ	0°	8°	0°	8°

3-pin SOT23 Outline Dimensions

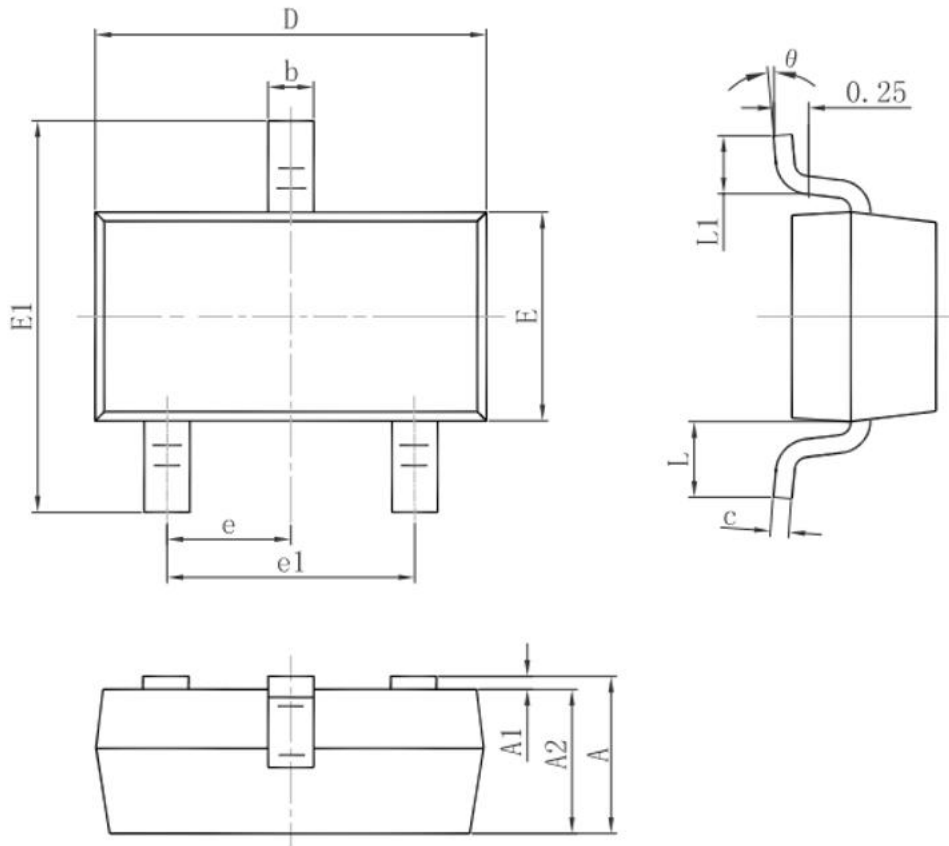

Symbol	Dimensions In Millimeters		Dimensions In Inches	
	Min.	Max.	Min.	Max.
A	0.900	1.150	0.035	0.045
A1	0.000	0.100	0.000	0.004
A2	0.900	1.050	0.035	0.041
b	0.300	0.500	0.012	0.020
c	0.080	0.150	0.003	0.006
D	2.800	3.000	0.110	0.118
E	1.200	1.400	0.047	0.055
E1	2.250	2.550	0.089	0.100
e	0.950 TYP.		0.037 TYP.	
e1	1.800	2.000	0.071	0.079
L	0.550 REF.		0.022 REF.	
L1	0.300	0.500	0.012	0.020
θ	0°	8°	0°	8°

Product Tape and Reel Specifications
3-pin TO92 Reel Dimensions (Unit :mm)

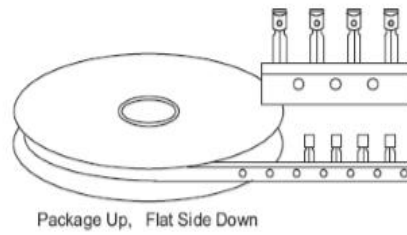
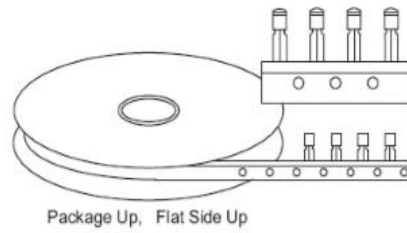
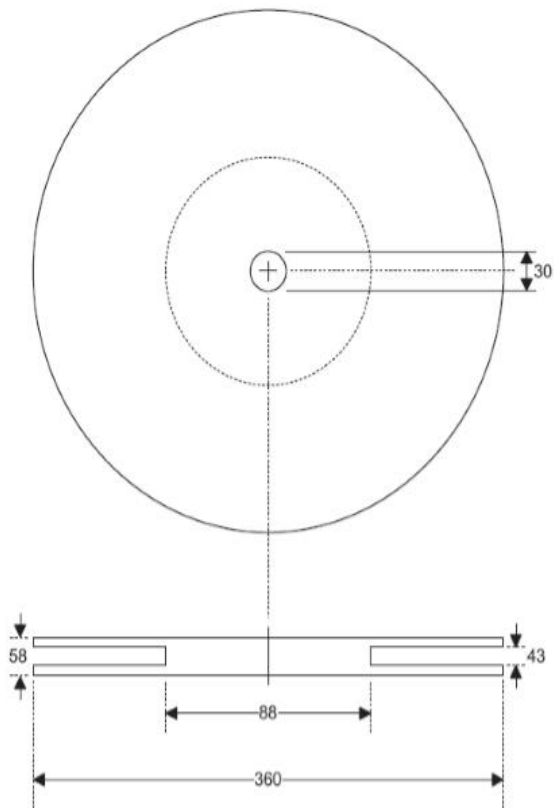

Reel Dimensions

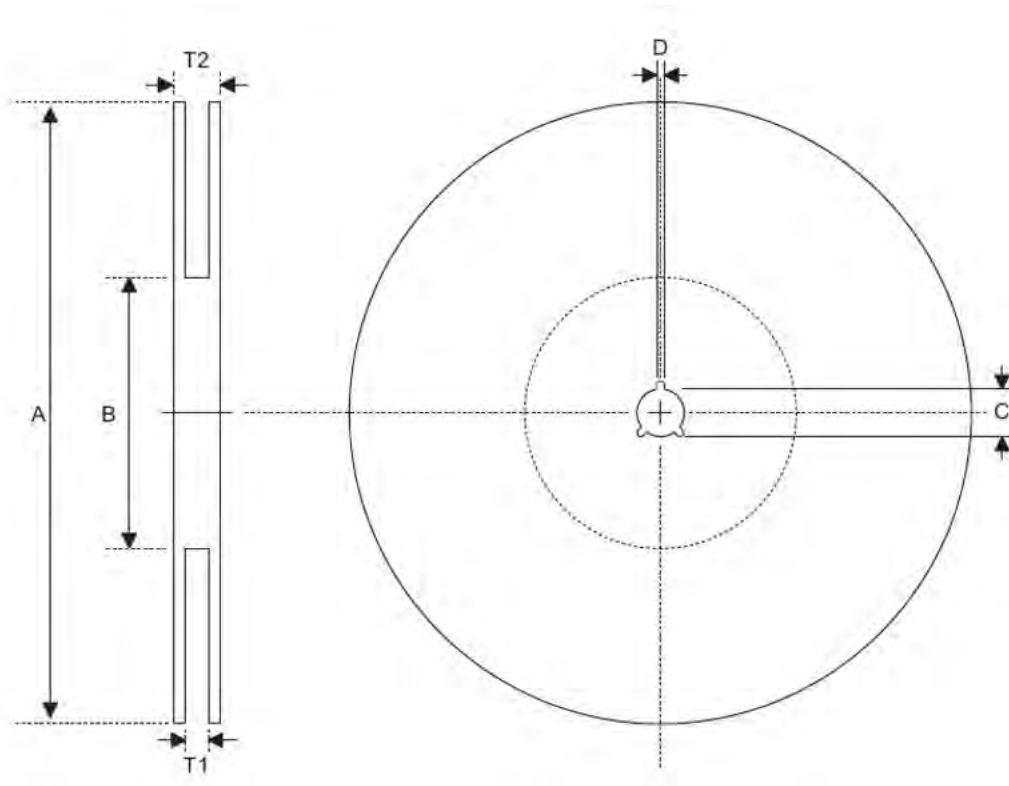

SOT89

Symbol	Description	Dimensions in mm
A	Reel Outer Diameter	180.0±1.0
B	Reel Inner Diameter	62.0±1.5
C	Spindle Hole Diameter	12.75 ^{+0.15/-0.00}
D	Key Slit Width	1.90±0.15
T1	Space Between Flange	12.4 ^{+0.2/-0.00}
T2	Reel Thickness	17.0 ^{+0.0/-0.4}

SOT23-5

Symbol	Description	Dimensions in mm
A	Reel Outer Diameter	178.0±1.0
B	Reel Inner Diameter	62.0±1.0
C	Spindle Hole Diameter	13.0±0.2
D	Key Slit Width	2.50±0.25
T1	Space Between Flange	8.4 ^{+1.5/-0.0}
T2	Reel Thickness	11.4 ^{+1.5/-0.0}

Carrier Tape Dimensions

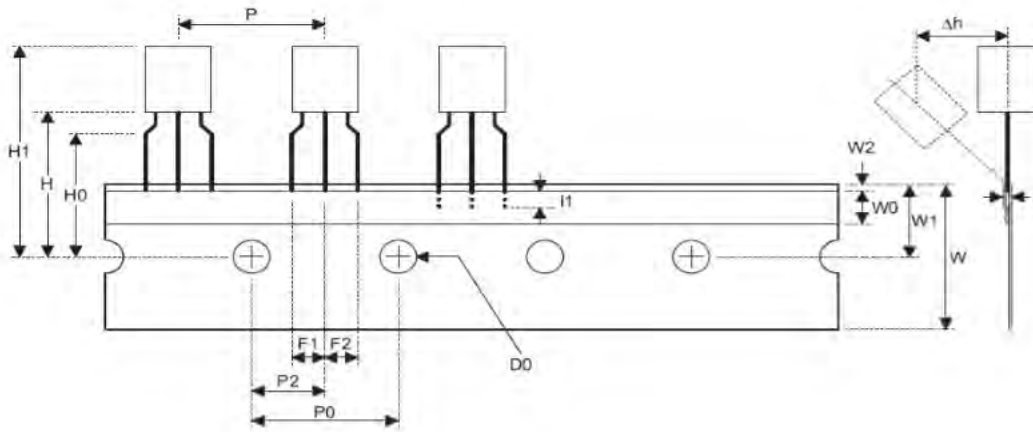

TO92

Symbol	Description	Dimensions in mm
I1	Taped Lead Length	(2.5)
P	Component Pitch	12.7±1.0
P ₀	Perforation Pitch	12.7±0.3
P ₂	Component to Perforation (Length Direction)	6.35±0.40
F ₁	Lead Spread	2.5 ^{+0.4/-0.1}
F ₂	Lead Spread	2.5 ^{+0.4/-0.1}
Δh	Component Alignment	0.0±0.1
W	Carrier Tape Width	18.0 ^{+1.0/-0.5}
W ₀	Hold-down Tape Width	6.0±0.5
W ₁	Perforation Position	9.0±0.5
W ₂	Hold-down Tape Position	(0.5)
H ₀	Lead Clinch Height	16.0±0.5
H ₁	Component Height	Less than 24.7
D ₀	Perforation Diameter	4.0±0.2
t	Taped Lead Thickness	0.7±0.2
H	Component Base Height	19.0±0.5

Note: Thickness less than 0.38_0.05mm~0.5mm

P₀ Accumulated pitch tolerance: _1mm/20pitches.

() Bracketed figures are for consultation only

Carrier Tape Dimensions

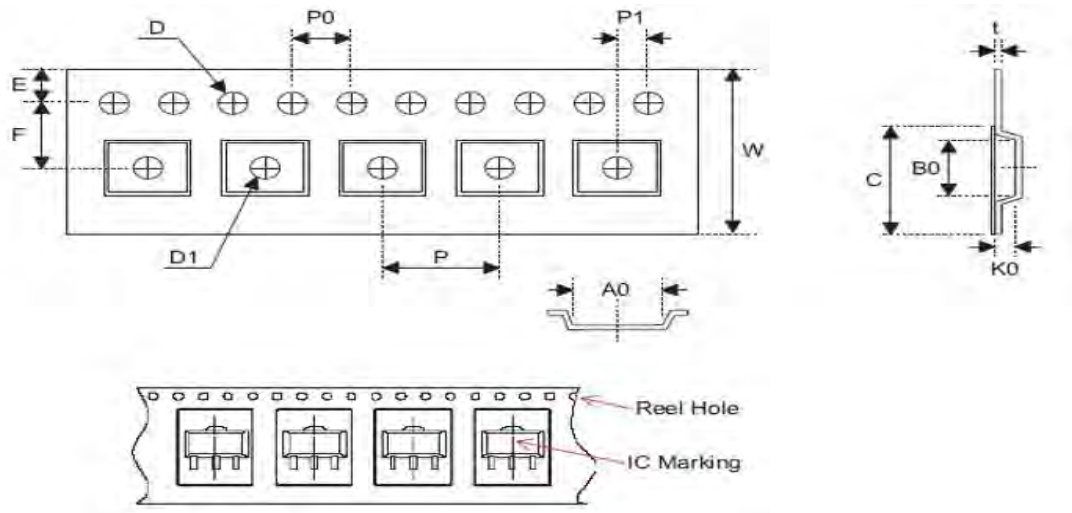

SOT89

Symbol	Description	Dimensions in mm
W	Carrier Tape Width	12.0 ^{+0.3/-0.1}
P	Cavity Pitch	8.0±0.1
E	Perforation Position	1.75±0.10
F	Cavity to Perforation (Width Direction)	5.50±0.05
D	Perforation Diameter	1.5 ^{+0.1/-0.0}
D1	Cavity Hole Diameter	1.5 ^{+0.1/-0.0}
P0	Perforation Pitch	4.0±0.1
P1	Cavity to Perforation (Length Direction)	2.0±0.1
A0	Cavity Length	4.8±0.1
B0	Cavity Width	4.5±0.1
K0	Cavity Depth	1.8±0.1
t	Carrier Tape Thickness	0.300±0.013
C	Cover Tape Width	9.3±0.1

SOT23-5

Symbol	Description	Dimensions in mm
W	Carrier Tape Width	8.0±0.3
P	Cavity Pitch	4.0±0.1
E	Perforation Position	1.75±0.10
F	Cavity to Perforation (Width Direction)	3.50±0.05
D	Perforation Diameter	1.5 ^{+0.1/-0.0}
D1	Cavity Hole Diameter	1.5 ^{+0.1/-0.0}
P0	Perforation Pitch	4.0±0.1
P1	Cavity to Perforation (Length Direction)	2.00±0.05
A0	Cavity Length	3.15±0.10
B0	Cavity Width	3.2±0.1
K0	Cavity Depth	1.4±0.1
t	Carrier Tape Thickness	0.20±0.03
C	Cover Tape Width	5.3±0.1

X-ON Electronics

Largest Supplier of Electrical and Electronic Components

Click to view similar products for [Linear Voltage Regulators](#) category:

Click to view products by [PROSEMI](#) manufacturer:

Other Similar products are found below :

[LV56831P-E](#) [LV5684PVD-XH](#) [MCDTSA6-2R](#) [L7815ACV-DG](#) [PQ3DZ53U](#) [LV56801P-E](#) [TLE42794G](#) [L78L05CZ/1SX](#) [L78LR05DL-MA-E](#) [636416C](#) [714954EB](#) [BA033LBSG2-TR](#) [LV5680P-E](#) [L78M15CV-DG](#) [L79M05T-E](#) [TLS202A1MBVHTSA1](#) [L78LR05D-MA-E](#) [NCV317MBTG](#) [NTE7227](#) [LV5680NPVC-XH](#) [LT1054CN8](#) [MP2018GZD-5-Z](#) [MP2018GZD-33-Z](#) [MIC5281-3.3YMM](#) [MC78L06BP-AP](#) [TA48LS05F\(TE85L,F\)](#) [TA78L12F\(TE12L,F\)](#) [TC47BR5003ECT](#) [TCR2LN12,LF\(S](#) [TCR2LN28,LF\(S](#) [TCR2LN30,LF\(S](#) [TCR3DF295,LM\(CT](#) [TCR3DF40,LM\(CT](#) [BA178M20CP-E2](#) [L78M12ABDT](#) [LM7812SX/NOPB](#) [LR645N3-G-P003](#) [LR645N3-G-P013](#) [ZXTR2005P5-13](#) [SCD7812BTG](#) [TCR3DF335,LM\(CT](#) [ZXTR2012K-13](#) [TLE42994E V33](#) [ZXTR2008K-13](#) [ZXTR2005K-13](#) [L88R05DL-E](#) [ADP3300ARTZ-2.7RL7](#) [LM120K-15/883](#) [IFX54441LDVXUMA1](#) [LM317D2T-TR](#)