

# SPECIFICATION FOR APPROVAL

※ This is a RoHS and REACH compliant product whose related documents are available on request.  
 ※ Graphic is only for dimensionally application.

## 1. PART NUMBER IDENTIFICATION

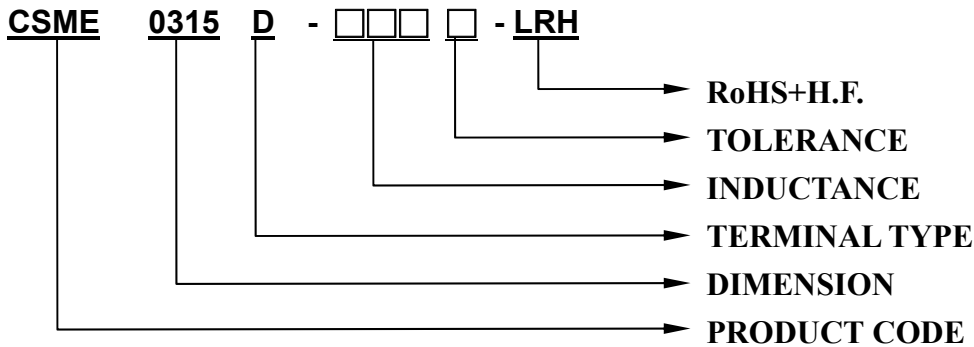

## 2. MECHANICAL DIMENSION

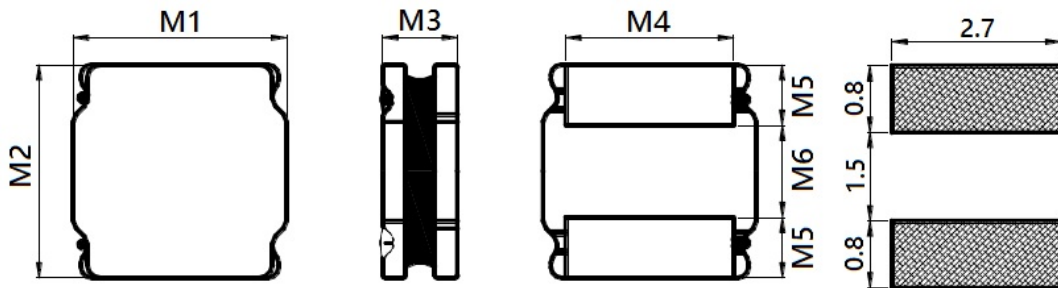

	DIM.	TOL.
M1	3.0	±0.2
M2	3.0	±0.2
M3	1.5	MAX.
M4	2.7	±0.2
M5	0.75	±0.2
M6	1.5	±0.2

## 3. STRUCTURE

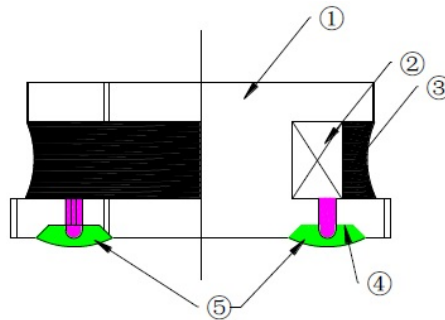

## 4. MATERIAL LIST

NO	PARTS	MATERIAL
1	DRUM CORE	Ni-Zn FERRITE CORE
2	WIRE	POLYURETHANE ENAMELED COPPER WIRE
3	ADHESIVE	EPOXY RESIN MAGNETIC POWDER
4	PLATING ELECTRODES	PLATING: Ag 10-20 um Ni 1-3 um Sn 3-7 um
5	OUTER ELECTRODES	TOP SURFACE SOLDER COATING Sn99%、Ag0.3%、Cu0.7%

## 5. ELECTRICAL CHARACTERISTICS

Part Number.	Inductance ( $\mu$ H)	DCR ( $m\Omega$ ) $\pm 30\%$	Isat (A) MAX.	Irise (A) MAX.
CSME0315D-1R0N-LRH	1.0	30	2.10	2.10
CSME0315D-1R5N-LRH	1.5	38	1.80	1.82
CSME0315D-2R2M-LRH	2.2	58	1.48	1.50
CSME0315D-3R3M-LRH	3.3	78	1.21	1.23
CSME0315D-4R7M-LRH	4.7	120	1.02	1.04
CSME0315D-6R8M-LRH	6.8	160	0.87	0.88
CSME0315D-100M-LRH	10	220	0.70	0.71
CSME0315D-220M-LRH	22	520	0.47	0.47

TOLERANCE : M:  $\pm 20\%$  、 N:  $\pm 30\%$

※ INDUCTANCE : @100KHz, 0.25V

※ TEST MACHINE : HIOKI3532-50 OR EQUIVALENT

※ DC RESISTANCE : HIOKI 3540 OR EQUIVALENT

※ ISAT / IRISE : HP4284+42841A OR EQUIVALENT

※ OPERATING TEMPERATURE : -40°C ~ +125°C.

※ INDUCTANCE DROPS NO MORE THAN 30% OF INITIAL VALUE AT ISAT.

※ TEMPERATURE RISES :  $\Delta t < 40^\circ\text{C}$  AT IRMS.

※ MSL : LEVEL 1.

## 6. RELIABILITY PERFORMANCE

6-1.Storage Temperature range :  $-40^{\circ}\text{C} \sim +105^{\circ}\text{C}$

6-2.Operating temperature range :  $-40^{\circ}\text{C} \sim +125^{\circ}\text{C}$  (Including coil's self temperature rise)

6-3.External appearance : No external defects can be found in the visual inspection.

6-4.Electrode strength : No electrode detachment should be found when the device is pushed in two directions of X and Y with the force of 10.0N for  $60 \pm 2$  seconds after soldering between copper plate and the electrodes. (Refer to figure at right)

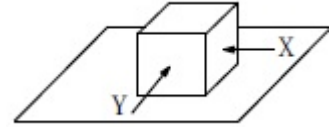

6-5.Vibration test : Inductance deviation is within  $\pm 10.0\%$  after 1 hour sweeping vibration in each three directions, namely, forward and backward, up and down, right and left. The frequency is  $10 \sim 55 \sim 10\text{Hz}$  and the amplitude of 1 minute cycle is 1.5mm PP.

6-6.Humidity test : Inductance deviation is within  $\pm 5.0\%$  after  $96 \pm 4$  hours test under the condition of relative humidity of  $90 \sim 95\%$  and temperature of  $60 \pm 2^{\circ}\text{C}$ , and 1 hour storage under room ambient conditions after the device is wiped with dry cloth.

## 7. TYPICAL RoHS REFLOW PROFILE

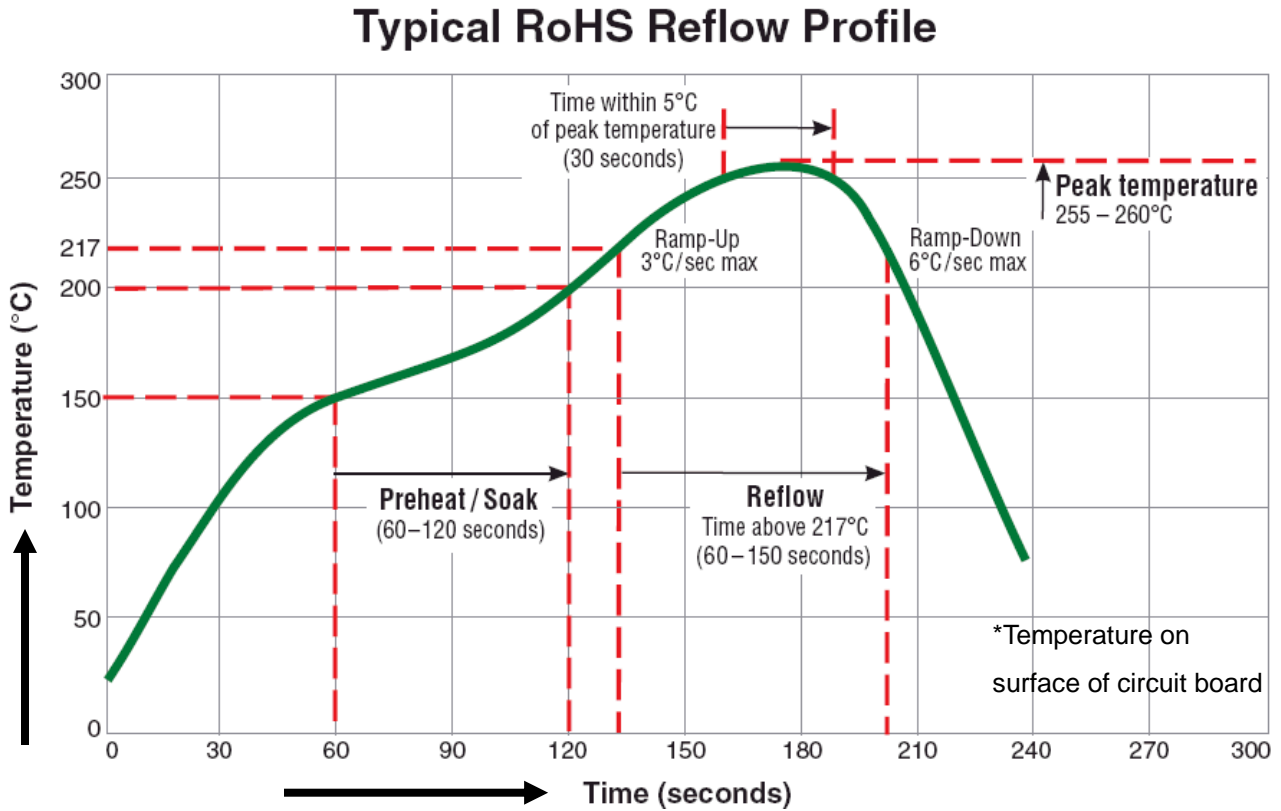

The products may be exposed to reflow soldering process of above profile up to two times.

## 8. PACKAGING

### 8-1 OUTER PACKING

2 KPCS/REEL;20 KPCS/INNER BOX;80 KPCS/OUTER BOX

### 8-2 CARRIER TAPE DIMENSIONS

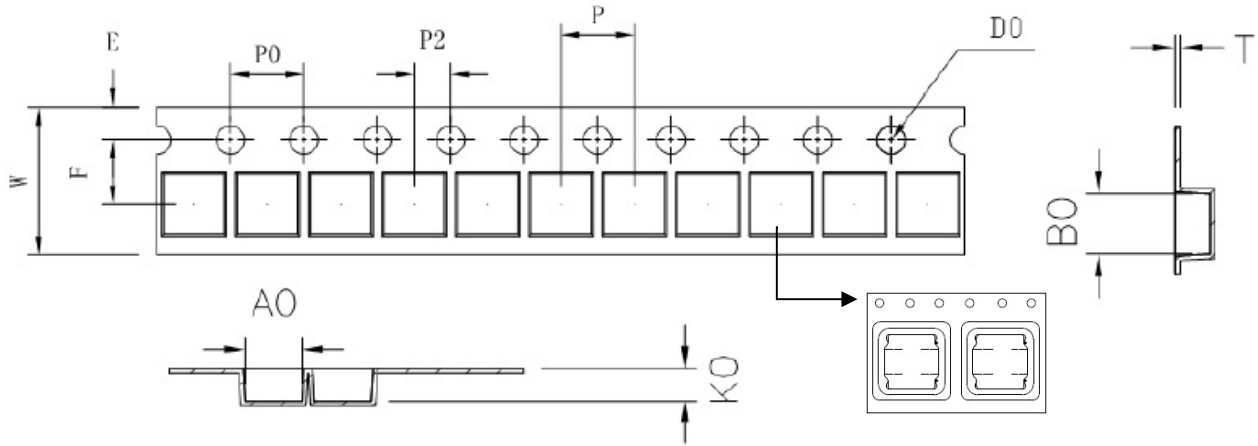

UNIT : mm

ITEM	W	P	F	E	D0	P0	P2	T	A0	B0	K0
DIM	8.00	4.00	3.50	1.75	1.50	4.00	2.00	0.25	3.3	3.3	1.9
TOLE	±0.3	±0.1	±0.05	±0.1	+0.1	±0.1	±0.05	±0.05	±0.05	±0.05	±0.05

### 8-3 CARRIER REEL DIMENSIONS

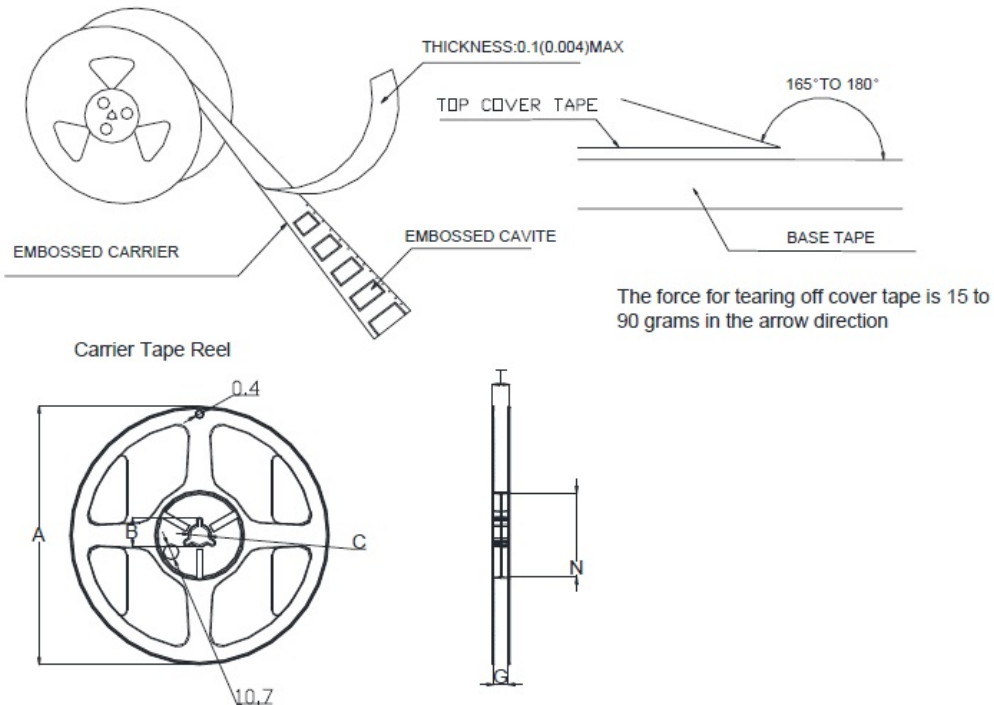

UNIT : mm

Type	A	B	C	G	N	T
8mm	178	20±0.8	13±0.4	9	60	10.8

## X-ON Electronics

Largest Supplier of Electrical and Electronic Components

*Click to view similar products for [Fixed Inductors](#) category:*

*Click to view products by [Prosperity](#) manufacturer:*

Other Similar products are found below :

[CR32NP-100KC](#) [CR54NP-470LC](#) [70F224AI](#) [MGDQ4-00004-P](#) [MHQ1005P10NJ](#) [MHQ1005P1N0S](#) [MHQ1005P2N4S](#) [MHQ1005P3N6S](#)  
[MHQ1005P5N1S](#) [MHQ1005P8N2J](#) [PE-53601NL](#) [PE-53602NL](#) [PG0936.113NLT](#) [9220-20](#) [9310-16](#) [PM06-2N7](#) [PM06-39NJ](#) [A01TK](#)  
[1206CS-471XJ](#) [HC2-R47-R](#) [HC8-1R2-R](#) [HCF1305-3R3-R](#) [1206CS-151XG](#) [RCH664NP-140L](#) [RCH664NP-4R7M](#) [RCP1317NP-391L](#)  
[RCR110DNP-331L](#) [DH2280-4R7M](#) [DS1608C-106](#) [B10TJ](#) [B82498B3101J000](#) [ELJ-RE27NJF2](#) [1812CS-153XJ](#) [1812CS-183XJ](#) [1812CS-](#)  
[223XJ](#) [1812LS-104XJ](#) [1812LS-105XJ](#) [1812LS-124XJ](#) [1812LS-154XJ](#) [1812LS-223XJ](#) [1812LS-224XJ](#) [1812LS-563XJ](#) [1812LS-683XJ](#)  
[1812LS-824XJ](#) [NIN-FB101JTR110F](#) [NIN-FB471JTR62F](#) [NIN-FC1R5JTR220F](#) [NIN-HCR15JTRF](#) [NIN-HCR33JTRF](#) [NIN-HDR22JTRF](#)