

信昌電子陶瓷股份有限公司

Prosperity Dielectrics Co., Ltd.

No.566-1, Gaoshi Rd., Lujhu, Yangmei Dist., Taoyuan City 32668, Taiwan, R.O.C.

Tel. : +886-3-4753355

Fax : +886-3-4854959

SPECIFICATION FOR APPROVAL

DATE :

CUSTOMER :

PART NAME :

Metal Strip Type Halogen Free Current Sensing Resistors

CUSTOMER'S DWG. NO. :

CUSTOMER'S PART NO. :

PDC PART NO. :

FMF SERIES APPROVED

DESCRIPTION. :

ACTION	"V"	CUSTOMER'S SIGNATURE	NOTE
RESULT			
FULL APPROVED			
CONDITIONAL APPROVED			
REJECTED			

OUR ACTION	SIGNATURE
PREPARED By	Jenny Tseng
CHECKED By	Tony Chou
APPROVED By	Byron Tsai

CUSTOMER SIGNATURE FOR ACCEPTANCE
--------------------------------------

1. Features .....	2
2. Applications.....	2
3. Dimension and construction .....	2
4. Power Derating Curve .....	2
5. Rating .....	3
6. Part Number .....	5
7. Resistance Marking .....	5
8. Reliability Performance.....	6
9. Packing .....	9
10. Storage & Handling .....	10



### 1. Features

- High power rating and low TCR.
- Low resistance and high precision (1%).
- Low inductance design, less than 1.0nH available.
- Excellent reliability and suitable cost.
- Suitable for lead free soldering.
- High precision trimming implement.
- RoHS compliant & Halogen Free.

### 2.Applications

- Switching model power supply.
- Battery pack.
- Notebook, Tablet PC
- Test Instrument.
- Power Amplifier.

### 3.Dimension and Construction

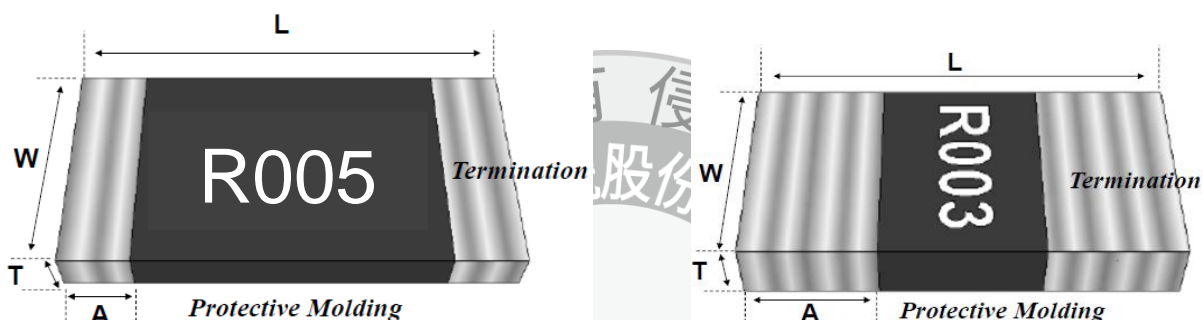

Item	Protective Molding	Resistive Element	Internal Terminal	External Terminal
Material	Resin	Alloy Metal	Copper	Solder

Unit : mm

FMF	L	W	T	a
1206 1~2mΩ	3.20±0.20	1.70±0.20	0.70±0.20	1.10±0.25
1206 3~30mΩ	3.10±0.20	1.65±0.20	0.60±0.20	0.60±0.20
2512 4~100mΩ	6.20±0.20	3.25±0.20	0.60±0.20	0.80±0.20
2512 1,2,3 mΩ	6.40±0.20	3.25±0.20	0.75±0.20	2.00±0.20
2512 3W 4~100mΩ	6.20±0.20	3.25±0.20	0.65±0.20	0.80±0.20
2512 3W 2,3 mΩ	6.40±0.20	3.25±0.20	0.75±0.20	2.00±0.20
2512 3W 1mΩ	6.40±0.20	3.25±0.20	0.80±0.20	2.00±0.20

### 4.Power Derating Curve

Operating Temperature Range: -55 to +170 deg.C

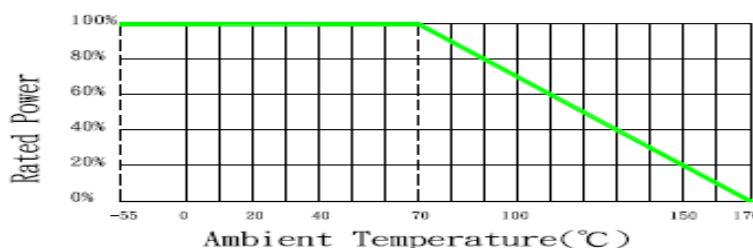

## 5.Rating

Table A.

Rating Type	Tolerance (%)	Rating 70°C (W)	Max. Working Current (Voltage)*	Max. Overload Current (Voltage)*	Alloy Type	Temperature coefficient of Resistance (ppm/°C)**	Resistance (mΩ) ***
<b>FMF06</b> <b>1206</b>	<b>±1%(F)</b> <b>±2%(G)</b> <b>±5%(J)</b>	<b>0.5</b>	22.4A (111mV)	50.0A (250mV)	Low EMF	<b>±75</b>	<b>1,2</b>
						<b>±70</b>	<b>3,4,5,6,7,8,9,</b> <b>10,15,20,25</b>
			Standard	<b>±50</b>	<b>5,10,15,15.5</b> <b>18,20,25,30</b>		
		<b>1</b>	31.6A (158mV)	70.7A (354mV)	Low EMF	<b>±75</b>	<b>1,2</b>
						<b>±70</b>	<b>3,4,5,6,7,8,9,</b> <b>10,15,20,25</b>
			Standard	<b>±50</b>	<b>5,10,15,15.5</b> <b>18,20,25,30</b>		
<b>FMF25</b> <b>2512</b>	<b>±1%(F)</b> <b>±2%(G)</b> <b>±5%(J)</b>	<b>1</b>	31.6A (158mV)	70.7A (354mV)	Low EMF	<b>±70</b>	<b>1,2,3,4,5</b> <b>10,15,20,25</b>
						<b>±50</b>	<b>3,4,5,6,7,8,9,10</b> <b>12,15,20,22,25,30</b> <b>33,35,40,50,60,70</b> <b>75,80,100</b>
			Standard	<b>±50</b>	<b>3,4,5,6,7,8,9,10</b> <b>12,15,20,22,25,30</b> <b>33,35,40,50,60,70</b> <b>75,80,100</b>		
		<b>2</b>	44.7A (224mV)	100A (500mV)	Low EMF	<b>±70</b>	<b>1,2,3,4,5</b> <b>10,15,20,25</b>
						<b>±50</b>	<b>3,4,5,6,7,8,9,10</b> <b>12,15,20,22,25,30</b> <b>33,35,40,50,60,70</b> <b>75,80,100,150</b>
			Standard	<b>±50</b>	<b>3,4,5,6,7,8,9,10</b> <b>12,15,20,22,25,30</b> <b>33,35,40,50,60,70</b> <b>75,80,100,150</b>		

Note:

- (i)  $E = \sqrt{P \cdot R}$  or Max. Working Voltage whichever is lower.
- (ii) E : Working Voltage(V) , P : Rated Power (W) , R : Resistance Value(Ω)
- (iii) Please keep the surface temperature do not exceed 105°C when full rated power applied. Solder-pad and trace size should be >300 mm<sup>2</sup>.
- (iv) \* : Related number are depend on specific items only. \*\* : TCR Hot (+25~+155°C).
- (v) R-value might be variance depend on soldering conditions and please consider this influence before use milli-ohm resistors, and strongly suggest use the recommend solder pad to design your circuits.

Table B.

Rating Type	Rating 70°C (W)	Max. Working Current (Voltage)*	Max. Overload Current (Voltage)*	Resistance Tolerance (%)	Temperature coefficient of Resistance (ppm/°C)**	Resistance (mΩ) ***
<b>FMF25 2512</b> Low EMF	<b>3</b>	54.8A (245mV)	122.5A (548mV)	±1%(F) ±2%(G) ±5%(J)	±70	<b>1,2,3,4,5,6,7,8,9,10</b>
					±50	<b>20</b>
<b>FMF25 2512</b> Standard	<b>3</b>	24.5A (812mV)	54.8A (1817mV)	±1%(F) ±2%(G) ±5%(J)	±70	<b>5,6,8,10</b>
					±50	<b>12,14,15,16,18,20 25,30,33,35,40,50 60,75,80,100</b>

Note:

- (i) E = or Max. Working Voltage whichever is lower.
- (ii) E : Working Voltage(V) · P : Rated Power (W) · R : Resistance Value(Ω)
- (iii) Please keep the surface temperature do not exceed 105°C when full rated power applied. Solder-pad and trace size should be >300 mm<sup>2</sup>.
- (iv) \* : Related number are depend on specific items only. \*\* : TCR Hot (+25~+155°C).
- (v) R-value might be variance depend on soldering conditions and please consider this influence before use milli-ohm resistors, and strongly suggest use the recommend solder pad to design your circuits.

Table C. Metal Jumper

Rating Type	Max. Working Current	Max. Overload Current	Resistance
<b>FMF06 1206</b> <b>FMF06JTH000 -LH</b>	<b>80A</b>	<b>100A</b>	<b>Max. 0.2mΩ</b>
<b>FMF25 2512</b> <b>FMF25JPJ000 -LH</b>	<b>120A</b>	<b>150A</b>	<b>Max. 0.1mΩ</b>

※Temperature Coefficient Resistance not applicable.

### 6.Part Number

Type	Size	Tolerance	Packing	Watt	Value	TCR	Special Code
<b>FMF</b>	<b>06</b> :1206	<b>F</b> :±1%	<b>T</b> :Paper Tape 4Kpcs (For 1206)	<b>F</b> : 1/2W	<b>XXXX</b> 4 digit	<b>∓</b> : As Rating table	General: Standard
	<b>25</b> :2512	<b>G</b> :±2% <b>J</b> :±5%	<b>P</b> :Plastic Tape 4Kpcs (For 2512)	<b>H</b> : 1W <b>J</b> : 2W <b>K</b> : 3W	<b>Jumper</b> : 000_ _: means blank.	<b>X</b> : Code use For 2512 R001.R002 R003 only	<b>LH</b> Low EMF <b>BH</b> AEC-Q200: Standard <b>LHM</b> Low EMF <b>BHM</b>

Example :

#### FMF06FTHR001-BH

→Metal strip, 1206 size, ±1%, paper tape, 1W, 1mΩ , low emf

#### FMF25FPKR010-BHM

→Metal strip, 2512 size, ±1%, plastic tape, 3W, 10mΩ , low emf, AEC-Q200

#### FMF25FPKR003XBH

→Metal strip, 2512 size, ±1%, plastic tape, 3W, 3mΩ , low emf, General

### 7.Marking

#### FMF 1206/2512

TOP : Marking. (4 Digits marking to identify the resistance value.)

“R005”=5mΩ

2512 “R001”=1mΩ

1206 “1”=1mΩ

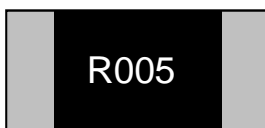

### Recommend Solder Pad Dimensions :

Type	W	D	L
<b>1206</b>	1.80	1.30	4.70
<b>1206</b> <b>R001/R002</b>	1.80	2.30	5.60
<b>2512</b>	3.70	1.60	7.60
<b>2512</b> <b>R001~R003</b>	4.00	3.00	7.30

Unit:mm

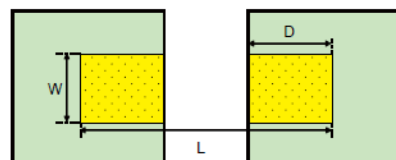

## 8. Reliability Performance (AEC-Q200)

\* Normal test items for general product.

Test Item	Specification	Test Method (AEC-Q200. IEC 60115)
*DC Resistance	J : $\pm 5\%$ G : $\pm 2\%$ F : $\pm 1\%$	<b>AEC-Q200 TABLE 7.1</b> IEC 60115-1 / JIS C 5201-1 , <b>Clause 4.5</b> Measure the resistance Value.
<b>High Temperature Exposure (Storage)</b>	J、G : $\Delta R \leq \pm 3\%$ F : $\Delta R \leq \pm 1\%$	<b>AEC-Q200 TABLE 7.3</b> 1000 hrs. @ T=170°C. Unpowered. Measurement at 24 $\pm$ 2 hours after test conclusion.
*Temperature Cycling	J、G : $\Delta R \leq \pm(1\% + 1m\Omega)$ F : $\Delta R \leq \pm(0.5\% + 1m\Omega)$ No mechanical damage.	<b>AEC-Q200 TABLE 7.4</b> 1000 Cycles (-55°C to +125°C). Measurement at 24 $\pm$ 2 hours after test conclusion. <b>IEC 60115-1 Clause 4.19 for General Type</b> Repeat 5 cycles as follows -55°C (30min.) $\rightarrow$ 25°C (2~3min.) $\rightarrow$ 155°C (30min.) $\rightarrow$ 25°C (2~3min.)
<b>Moisture Resistance</b>	J、G : $\Delta R \leq \pm(1\% + 0.5m\Omega)$ F : $\Delta R \leq \pm(0.5\% + 0.5m\Omega)$	<b>AEC-Q200 TABLE 7.6</b> Test 65°C/80~100%RH/10Cycles. Measurement at 24 $\pm$ 2 hours after test conclusion. (t=24hrs/cycle).
<b>Biased Humidity</b>	J、G : $\Delta R \leq \pm(3\% + 0.5m\Omega)$ F : $\Delta R \leq \pm(1\% + 0.5m\Omega)$	<b>AEC-Q200 TABLE 7.7</b> 1000 hours 85°C/85%RH. 10% of operating power. Measurement at 24 $\pm$ 2 hours after test conclusion.
<b>Operational Life</b>	J、G : $\Delta R \leq \pm(3\% + 0.5m\Omega)$ F : $\Delta R \leq \pm(1\% + 0.5m\Omega)$	<b>AEC-Q200 TABLE 7.8</b> Test 1000hr @ TA=125°C at specified rated power. Measurement at 24 $\pm$ 2 hours after test conclusion.
<b>External Visual</b>	No visual damage and refer PDC marking code.	<b>AEC-Q200 TABLE 7.9</b> Inspect device construction, marking and workmanship.
<b>Physical Dimension</b>	Within the spec.	<b>AEC-Q200 TABLE 7.10</b> Verify physical dimensions to the applicable device detail specification.

<b>Mechanical Shock</b>	Within product specification tolerance and no visible damage.	<b>AEC-Q200 TABLE 7.13</b> Test Peak value:100g's,Wave:Hail-sine, Duration:6ms,Velocity:12.3ft/sec.
<b>Vibration</b>	No mechanical damage.	<b>AEC-Q200 TABLE 7.14</b> 5 g's for 20 min., 12 cycles each of 3 orientations. Test from 10-2000 Hz.
<b>*Resistance to Solder Heat</b>	J、G : $\Delta R \leq \pm(1\% + 0.5m\Omega)$ F : $\Delta R \leq \pm(0.5\% + 0.5m\Omega)$ No mechanical damage.	<b>AEC-Q200 TABLE 7.15</b> Solder dipping @ 270°C±5°C for 10sec.±1sec.
<b>Thermal Shock</b>	J、G : $\Delta R \leq \pm(1\% + 0.5m\Omega)$ F : $\Delta R \leq \pm(0.5\% + 0.5m\Omega)$ No mechanical damage.	<b>AEC-Q200 TABLE 7.16</b> -55 to 155°C/ dwell time 15min/ Max transfer time 20sec/ 300cycles.
<b>ESD</b>	$\Delta R \leq \pm(1\% + 0.5m\Omega)$ No mechanical damage.	<b>AEC-Q200-002</b> Test contact min. 1KV.
<b>*Solder Ability</b>	Over 95% of termination must be covered with solder.	<b>AEC-Q200 TABLE 7.18</b> a)Baking 155°C 4H, dipping 235°C 5s b)Steam 1H, dipping 215°C 5s c)Steam 1H, dipping 260°C 7s <b>IEC 60115-1, Clause 4.17 for General Type</b> After immersing flux, dip in the 235±2°C molten solder bath for 3±0.5 sec.
<b>Flammability</b>	Refer UL-94.	<b>AEC-Q200 TABLE 7.20</b> UL-94 V-0 or V-1 are acceptable
<b>*Board Flex</b>	J、G : $\Delta R \leq \pm(1\% + 1m\Omega)$ F : $\Delta R \leq \pm(0.5\% + 1m\Omega)$ No mechanical damage.	<b>AEC-Q200 TABLE 7.21</b> Bending 2mm 2512.1206
<b>Terminal Strength</b>	No mechanical damage	<b>AEC-Q200 TABLE 7.22</b> Force 1 Kg for 60 seconds.



<b>*Short Time Overload</b>	J · G : $\Delta R \leq \pm(2\% + 0.5m\Omega)$ F : $\Delta R \leq \pm(1\% + 0.5m\Omega)$	<b>IEC 60115-1, Clause 4.13</b> 5 × Rated power for 5 seconds
<b>*Load Life Humidity</b>	J · G : $\Delta R \leq \pm(3\% + 0.5m\Omega)$ F : $\Delta R \leq \pm(1\% + 0.5m\Omega)$	<b>IEC 60115-1, Clause 4.24</b> 40±2°C with relative humidity 90% ~ 95% D.C. rated voltage for 1.5 hours ON 30 minutes OFF. Cycle repeated 1000 hours.
<b>*Temperature Coefficient of Resistance (TCR)</b>	Within the spec.	<b>IEC 60115-1, Clause 4.8</b> $T_1 \quad T_2$ Test temperature : 25°C ~ +155°C $TCR(ppm/^{\circ}C) = (R_2 - R_1) / R_1 \times 1 / (T_2 - T_1) \times 10^6$ (+25~ -55°C, please contact factory.)
<b>*Load Life</b>	J · G : $\Delta R \leq \pm(3\% + 0.5m\Omega)$ F : $\Delta R \leq \pm(1\% + 0.5m\Omega)$	<b>IEC 60115-1, Clause 4.25</b> Rated voltage for 1.5 hours for followed by a pause 0.5 hour at 70±2°C. Cycle repeated 1000 hours.
<b>*Insulation Resistance</b>	Between termination and coating must over 1000MΩ	<b>IEC 60115-1, Clause 4.6</b> Test voltage : 100±15V

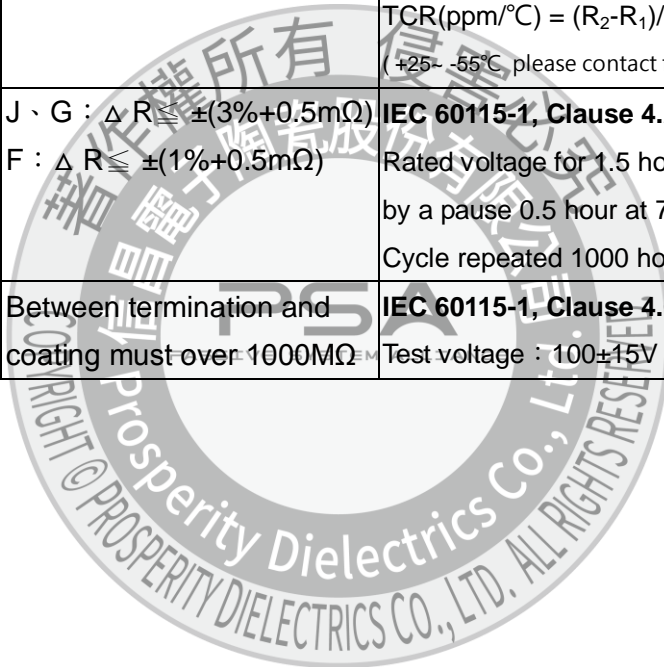

## 9. PACKAGING

### 9.1 Peel Strength of Top Cover Tape

The peel speed shall be about 300 mm/min

The peel force of top cover tape shall be between 0.1 to 0.7N

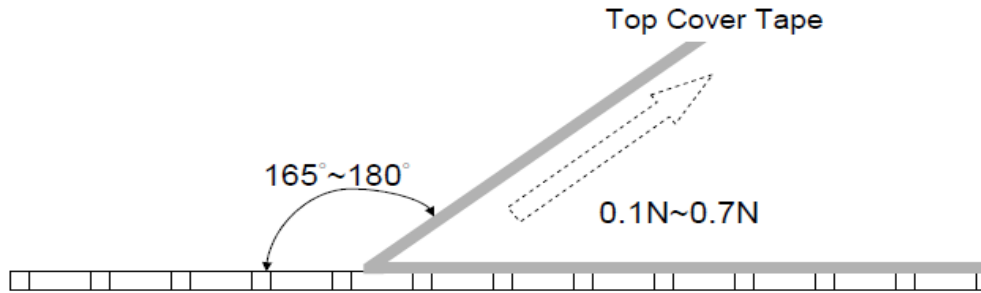

### 9.2 Tape Packaging Dimensions

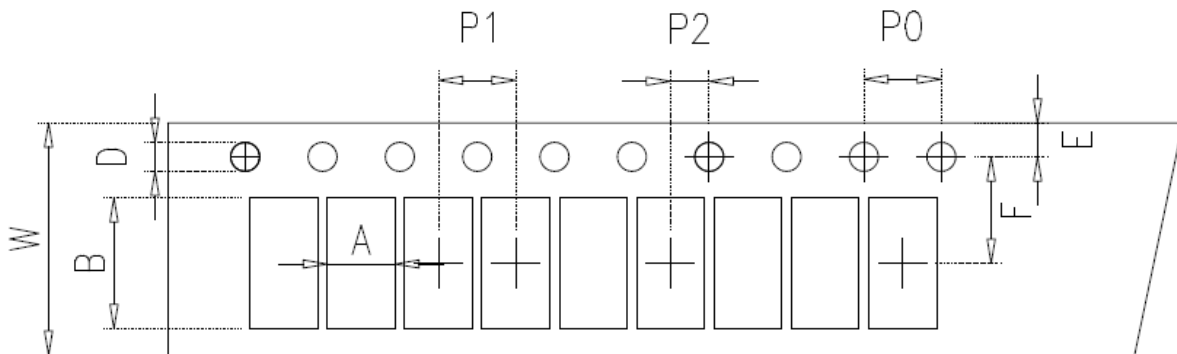

Size	A	B	W	F	E	P1	P2	P0	D
1206	2.00±0.20	3.60±0.20	8.00±0.30	3.50±0.05	1.75±0.10	4.00±0.10	2.00±0.05	4.00±0.10	1.50±0.10
2512	3.50±0.20	6.75±0.20	12.0±0.30	5.50±0.05	1.75±0.10	4.00±0.10	2.00±0.05	4.00±0.10	1.50±0.10

unit : mm

### 9.3 Reel Dimensions

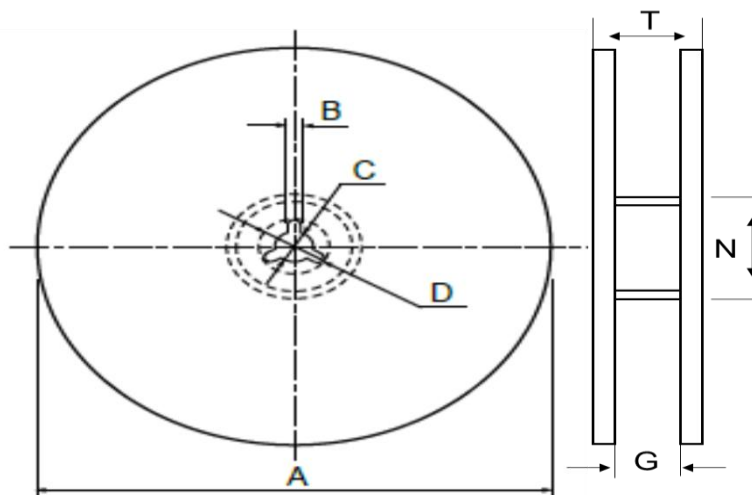

Size	Packaging Q'ty	A	N	C	D	B	G	T
1206	4kpcs/Reel	178.0±2.0	60.0±0.5	13.0±0.5	20(Min.)	2.0±0.5	10.0±1.5	14.9max.
2512	4kpcs/Reel	178.0±2.0	60.0±0.5	13.0±0.5	20(Min.)	2.0±0.5	13.8±1.5	16.7max.

### 10. Storage & Handling

... Products are recommended to be used up within one year as ensured shelf life.

Check solder ability in case shelf life extension is needed.

... To store products with following condition:

Temperature: 5 to 40°C ; Humidity: 20 to 70% relative humidity.

#### Precaution for use :

The AEC-Q200 series resistors is mainly used on general automotive equipment without safety considerations.

Please contact our company in advanced if you intend to use resistor for designing the equipment which may damage itself and the safety of third party. If necessary, please consider to add the protect circuit in devising process and obtaining fully safety evaluation. The contents of the acknowledgment is only used for our parent company, marketing subsidiaries and official marketing agents who purchase our products. Not applicable for the other nonofficial channels.

※ All products specification and data are subject to change without notice.

## X-ON Electronics

Largest Supplier of Electrical and Electronic Components

*Click to view similar products for [Current Sense Resistors - SMD category](#):*

*Click to view products by [Prosperity manufacturer](#):*

Other Similar products are found below :

[CRL0603-FW-R700ELF](#) [PFS35-200RF1](#) [CD2015FC-0.10-1%](#) [PR2512FKF7W0R004L](#) [RC1005F124CS](#) [RL73K3AR56JTDF](#) [RL7520WT-R001-F](#) [RL7520WT-R009-G](#) [RL7520WT-R020-F](#) [LRC-LR2010LF-01-R033J](#) [LRC-LR2512LF-01-R820J](#) [65709-330](#) [SP1R12J](#) [RL7520WT-R039-G](#) [RL7520WT-R002-F](#) [RL7520WT-R005-F](#) [KRL1632E-C-R200-F-T5](#) [KRL1632E-C-R200-F-T1](#) [Y14880R02000B9R](#) [RLP73M2AR075FTDF](#) [SR731ERTTP5R10F](#) [SR731ERTTP100J](#) [SR731ERTTP6R80F](#) [SR731ERTTP3R9J](#) [SR731ERTTP8R2J](#) [SR731ERTTP2R0J](#) [SR731ERTTP4R7J](#) [SR731ERTTP9R1J](#) [SR731ERTTP1R0J](#) [SR731ERTTP2R2J](#) [SR731ERTTP5R1J](#) [SR731ERTTP6R8J](#) [SR731ERTTP9R10F](#) [FCSL64R007JER](#) [73L4R10G](#) [73L4R75G](#) [73L4R33G](#) [73M1R051F](#) [73WL4R020J](#) [73L2R68J](#) [73L2R22J](#) [73L2R33J](#) [CC1512FC-0.015-5%](#) [ULRG2-2512-R0075-F-LF-SLT](#) [ULR3N-R00075FT2](#) [ULR3N-R0009FT2](#) [SLN3TTED80L6F](#) [JW104X15X4](#) [JW105X19X5](#) [HVR06FTEV2403](#)