

SPECIFICATION FOR APPROVAL

CUSTOMER	_____
CUST. PART NO.	_____
CUST. DOC. REV.	_____
DESCRIPTION	<u>HIGH CURRENT POWER CHOKE (ROHS+H.F.)</u>
SAMPLE LOT NO.	_____
PART NO.	MCS1040-XXXMXX
DOC. REV.	ORIG
DATE	_____

Once you approve this part, please sign and return this page to the following marked location.

Customer Signature: _____ **Date:** _____

This part currently development section.

Production line can produce this series of products.

■ Sales Office-Headquarter

No. 566-1, Kao-Shi Rd., Yangmei, Taoyuan 32668,
Taiwan
TEL: +886-3-475-3355
FAX: +886-3-485-4959

Yong Zhou Plant

Tao-Yuan Rd., Fenghuang Park, Lengshuitan
District, Yongzhou, Hunan 425000, P.R.C.
TEL: +86-746-8610-180
FAX: +86-746-8610-181

Sales Office-Dong Guan,China

No.638,Mei Jing West Road Xiniupo Administrative
Zone Dalang Town,Dong Guan City,GuangDong
Province,China.
TEL: +86-769-8555-0979
FAX: +86-769-8555-0972

TESTED BY	CHECKED BY	APPROVED BY

TABLE OF CONTENTS

INDEX	Page
■ Engineering Change Notice – Record	2
■ Product Identification	3
■ Product Dimension	3
■ Marking and Date code	3
■ Electrical Spec.	4
■ Reliability Performance	5
■ Reflow Chart	6
■ Package Form	7
■ Test Report	

SPECIFICATION FOR APPROVAL

CUSTOMER	CUSTOMER P/N	REV. -	SPL. LOT NO.	
PART NAME HIGH CURRENT POWER CHOKE (ROHS+H.F.)	PART NO. MCS1040-XXXMXX	REV. ORIG	DATE OF ISSUE	Q'TY 0 PCS

ENGINEERING CHANGE NOTICE – RECORD

REVISION NO.	REVISION DESCRIPTION	AUTHOR	DATE	REMARK
ORIG		<i>Gary Chang</i>		

SPECIFICATION FOR APPROVAL

※This is a RoHS and REACH compliant product whose related documents are available on request.

※Graphic is only for dimensionally application.

1. PRODUCT IDENTIFICATION

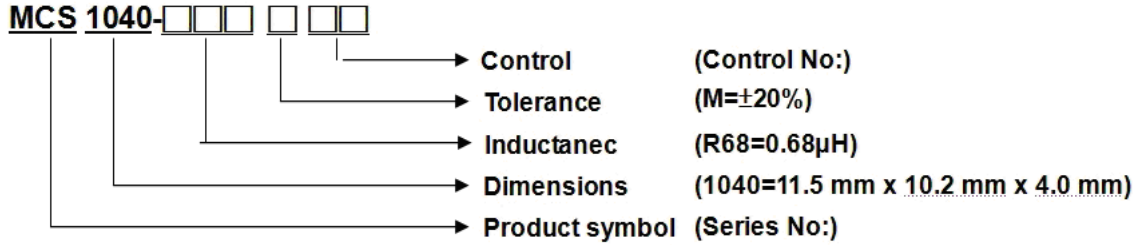

2. PRODUCT DIMENSION

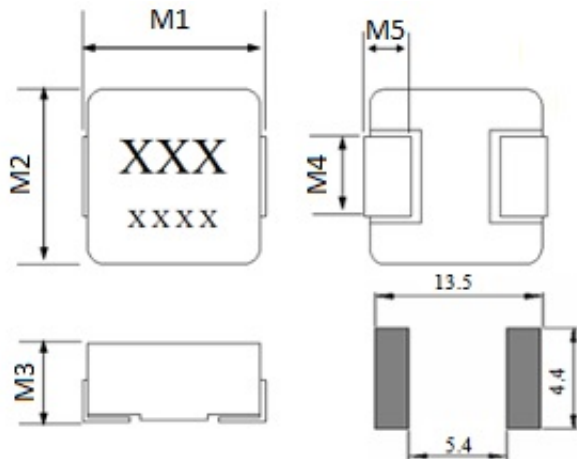

UNIT: mm

	DIM.	TOL.
M1	11.15	±0.35
M2	10.0	±0.3
M3	4.0	MAX.
M4	3.0	±0.5
M5	2.0	±0.5

3. MARKING AND DATE CODE

Marking ex:1.0uH → 1R0

Date code

XX XX → year and weekly ex:1033

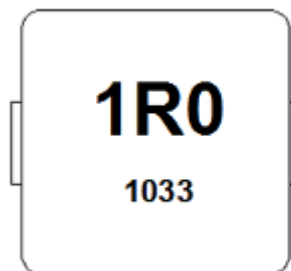
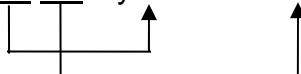

SPECIFICATION FOR APPROVAL

4. ELECTRICAL SPEC.

PART NO.	Inductance (μ H) $\pm 20\%$	DCR (m Ω) Typical 25 $^{\circ}$ C	DCR (m Ω) MAX.25 $^{\circ}$ C	Rated Current (A) Typical	I sat (A) Typical
MCS1040-R22MN1	0.22	0.80	1.0	30.0	50.0
MCS1040-R36MN1	0.36	1.1	1.2	34.0	40.0
MCS1040-R47MN1	0.47	1.3	1.55	25.0	35.0
MCS1040-R56MN1	0.56	1.6	1.8	25.0	32.0
MCS1040-R68MN1	0.68	2.4	2.7	22.0	30.0
MCS1040-1R0MN1	1.0	3.0	3.3	18.0	28.0
MCS1040-1R5MN1	1.5	3.8	4.2	16.0	21.0
MCS1040-2R2MN1	2.2	6.7	7.0	12.0	18.0
MCS1040-3R3MN1	3.3	10.8	11.8	10.0	16.0
MCS1040-4R7MN1	4.7	17.0	20.0	8.5	15.0
MCS1040-6R8MN1	6.8	22.5	25.0	6.5	9.0
MCS1040-8R2MN2	8.2	26.0	29.0	7.0	9.0
MCS1040-100MN1	10	27.0	30.0	7.5	8.5
MCS1040-150MCC	15	40.0	45.0	6.25	7.0
MCS1040-220MCC	22	60.0	66.0	5.0	5.5
MCS1040-330MCC	33	85.0	92.0	4.4	5.0
MCS1040-470MCC	47	130.0	145.0	3.3	3.5

TEST INSTRUMENT: CHROMA 16502 、Zentech1320+Zentech3305

- (1). Test Freq : 100KHz , 1.0V
- (2). All test data is referenced to 25 $^{\circ}$ C ambient.
- (3). Operating Temperature Range -55 $^{\circ}$ C to +125 $^{\circ}$ C.
- (4). Rated Current: DC current(A)that will cause an approximate Δ T of 40 $^{\circ}$ C.
- (5). I sat: DC current(A)that will cause Lo to drop approximately 30%.
- (6). The part temperature(ambient +temp rise)should not exceed 125 $^{\circ}$ C under worst case operating conditions. Circuit design, component placement, PWB trace size and thickness, airflow and other cooling provisions all affect the part temperature Part temperature should be verified

SPECIFICATION FOR APPROVAL

5. RELIABILITY PERFORMANCE

Reliability Experiment For Electrical

Test Item	Test Condition	Standard Source
Humidity Test	+40°C±2°C, humidity of 90%±5% (total 96 hours).	MIL-STD-202G Method 103B Test Condition B
High Temperature Test	1.Temperature: +125°C±2°C. 2.Test time: 48±2hrs.	IEC 68-2 Test Condition B
Low Temperature Test	1.Temperature: -40°C±2°C. 2.Test time: 48±2hrs.	IEC 68-2 Test Condition A
Thermal Shock	+125°C±5°C (30 minutes) ~ -40±5°C (30 minutes), temperature switch time: 5 minutes (total 50 cycles) Wind speeds 10m/sec.	Reference MIL-STD-202G Method 107G Test Condition B-2
Life Test	+70°C±5°C (300Hours).	Reference MIL-STD-202G Method 108A Test Condition B

Reliability Experiment For Physical

Test Item	Test Condition	Standard Source
Vibration Test	10-55-10HZ, amplitude: 1.5mm, direction: X, Y, Z axes, each axis 2 hours (total 6 hours).	MIL-STD-202G Method 201A
Solder Heat Resistance Test	IR/convection reflow: Peak Temp 255°C~260°C for 3~5 Sec. in air, Through 2 Cycle. Temperature Ramp:+1~4°C/sec.;; Above 217°C, must keep 90 s - 120 s.	Reference MIL-STD-202G Method 210F Test Condition K (Reflow)
Solder Ability Test	Soak in 245°C solder pot of 3~5 Sec., PAD must have 95% above coverage.	Reference J-STD-002D

SPECIFICATION FOR APPROVAL

6. TYPICAL RoHS REFLOW PROFILE

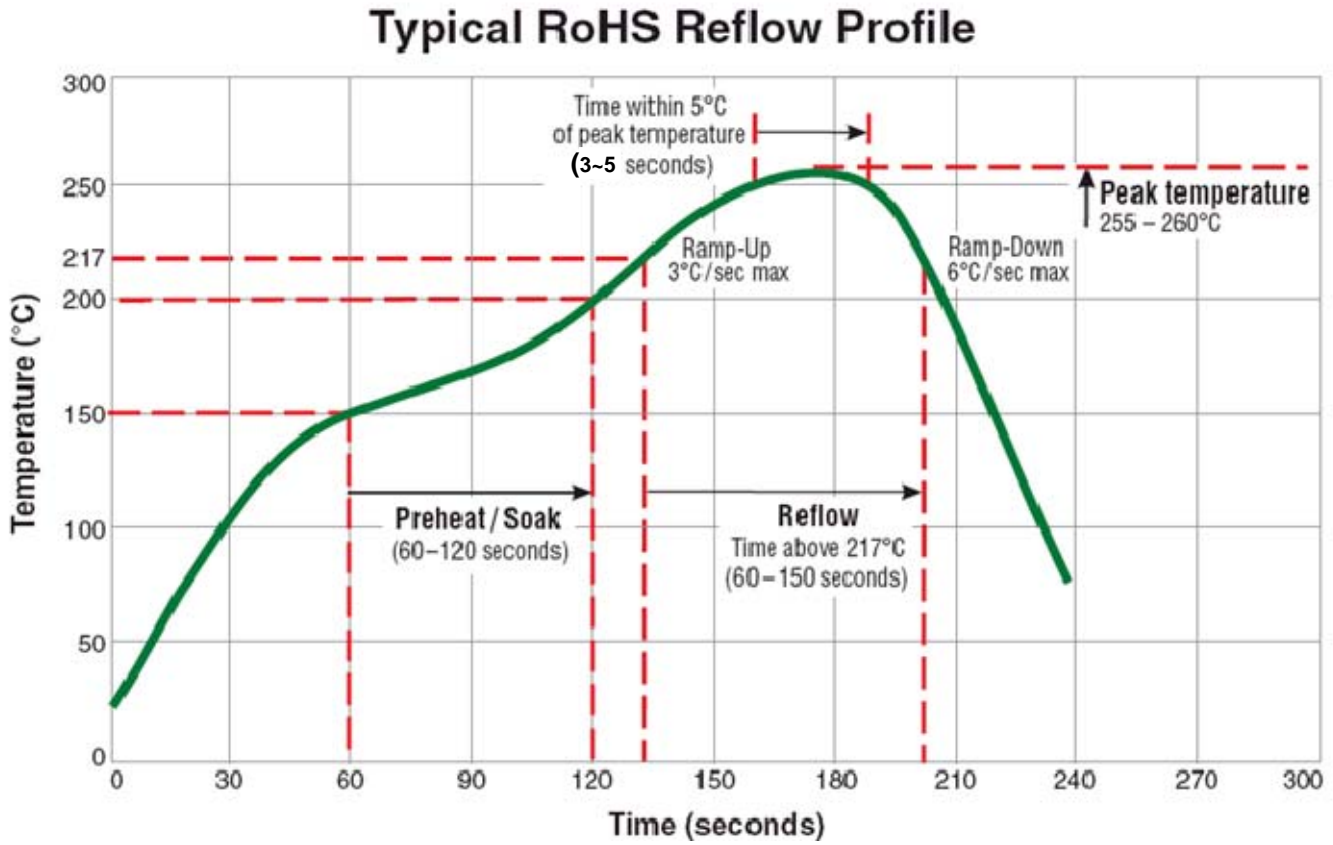

SPECIFICATION FOR APPROVAL

7. PACKAGING

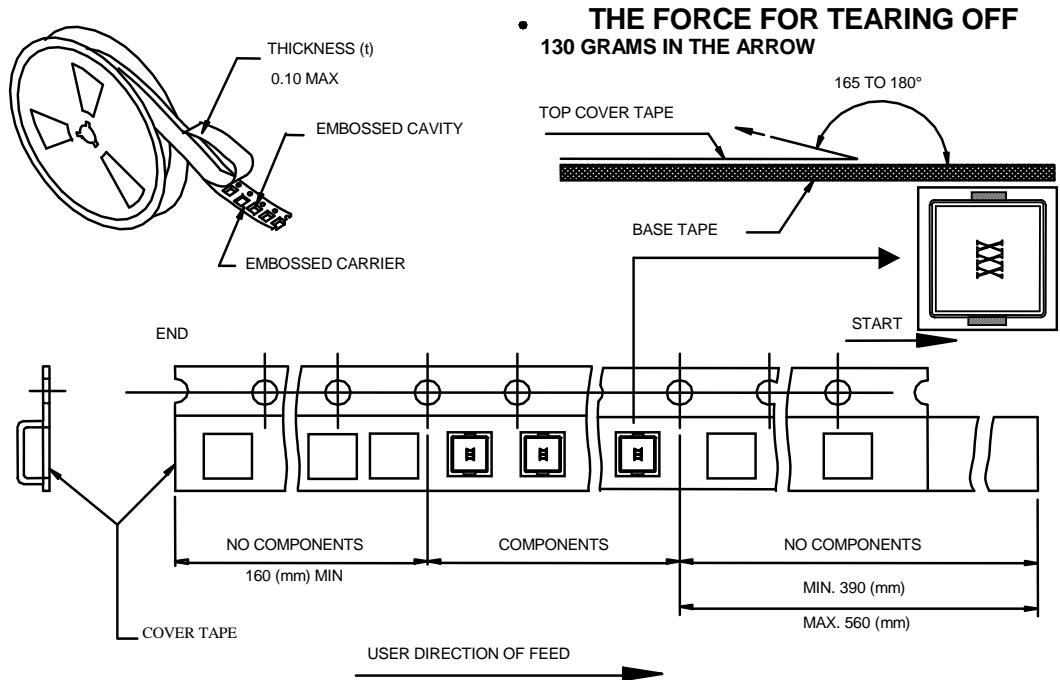

■ CARRIER TAPE REELS (mm)

MATERIAL: PLASTIC

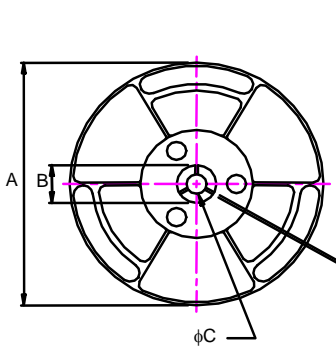

500 Parts per Reel

■ DIMENSIONS OF CARRIER TAPE (mm)

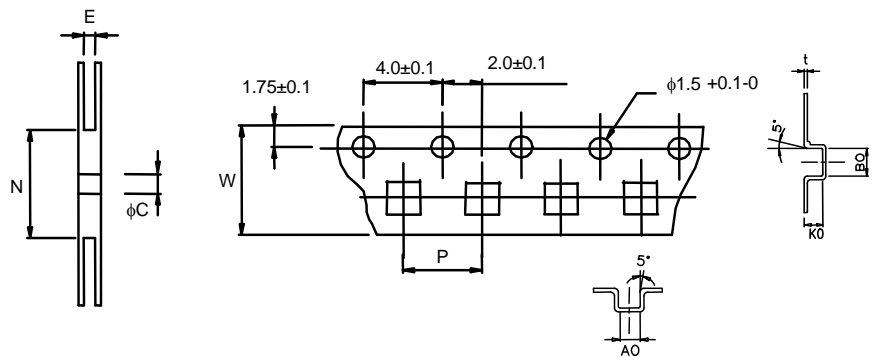

※ 10 sprocket hole pitch cumulative tolerance ±0.20

UNIT: mm

	A	B	C	E	N	P	W	t	A0	B0	K0
DIM.	330	25.0	13.0	24.6	100	16.0	24.0	0.4	10.6	11.7	4.25
TOL.	±0.2	±0.5	±0.5	±0.5	MIN	±0.1	±0.3	±0.05	±0.1	±0.1	±0.1

X-ON Electronics

Largest Supplier of Electrical and Electronic Components

Click to view similar products for [Fixed Inductors](#) category:

Click to view products by [Prosperity](#) manufacturer:

Other Similar products are found below :

[MLZ1608M6R8WTD25](#) [MLZ1608N6R8LT000](#) [MLZ1608N3R3LTD25](#) [MLZ1608N3R3LT000](#) [MLZ1608N150LT000](#)
[MLZ1608M150WTD25](#) [MLZ1608M3R3WTD25](#) [MLZ1608M3R3WT000](#) [MLZ1608M150WT000](#) [MLZ1608A1R5WT000](#)
[MLZ1608N1R5LT000](#) [B82432C1333K000](#) [PCMB053T-1R0MS](#) [PCMB053T-1R5MS](#) [PCMB104T-1R5MS](#) [CR32NP-100KC](#) [CR32NP-151KC](#) [CR32NP-180KC](#) [CR32NP-181KC](#) [CR32NP-1R5MC](#) [CR32NP-390KC](#) [CR32NP-3R9MC](#) [CR32NP-680KC](#) [CR32NP-820KC](#)
[CR32NP-8R2MC](#) [CR43NP-390KC](#) [CR43NP-560KC](#) [CR43NP-680KC](#) [CR54NP-181KC](#) [CR54NP-470LC](#) [CR54NP-820KC](#) [CR54NP-8R5MC](#)
[MGDQ4-00004-P](#) [MGDU1-00016-P](#) [MHL1ECTTP18NJ](#) [MHL1JCTTD12NJ](#) [PE-51506NL](#) [PE-53601NL](#) [PE-53630NL](#) [PE-53824SNLT](#) [PE-62892NL](#) [PE-92100NL](#) [PG0434.801NLT](#) [PG0936.113NLT](#) [PM06-2N7](#) [PM06-39NJ](#) [HC2LP-R47-R](#) [HC2-R47-R](#) [HC3-2R2-R](#) [HC8-1R2-R](#)