

SPECIFICATION FOR APPROVAL

CUSTOMER	_____
CUST. PART NO.	_____
CUST. DOC. REV.	_____
DESCRIPTION	MOLDING POWER CHOKE(RoHS+H.F.)
SAMPLE LOT NO.	S202112-0075
PART NO.	MCS1040-XXXMY1
DOC. REV.	A
DATE	2022/02/09

Once you approve this part, please sign and return this page to the following marked location.

Customer Signature: _____ Date: _____

This part currently development section.

Production line can produce this series of products.

Sales Office-Headquarter

No. 566-1, Kao-Shi Rd., Yangmei, Taoyuan 32668,
Taiwan
TEL: +886-3-475-3355
FAX: +886-3-485-4959

ShenZhen Plant

2nd Floor, No. 16, Daxing 1st Road, Bu Chung
Community, Shajing Street, Bao'an
District, Shenzhen
TEL: +86-755-2720-8041

Sales Office-Dong Guan, China

No.638, Mei Jing West Road Xiniupo Administrative
Zone Dalang Town, Dong Guan City, GuangDong
Province, China.
TEL: +86-769-8555-0979
FAX: +86-769-8555-0972

ISSUE BY	CHECKED BY	APPROVED BY
<i>Jones Weng</i>	<i>Gillian Nan</i>	<i>Albert Tsao</i>

TABLE OF CONTENTS

INDEX	Page
■ Engineering Change Notice – Record	2
■ Part Number Identification	3
■ Mechanical Dimension	3
■ Marking	3
■ Electrical Specification	4
■ Reliability Performance	5
■ Reflow Chart	6
■ Packing	7
■ Test Report	

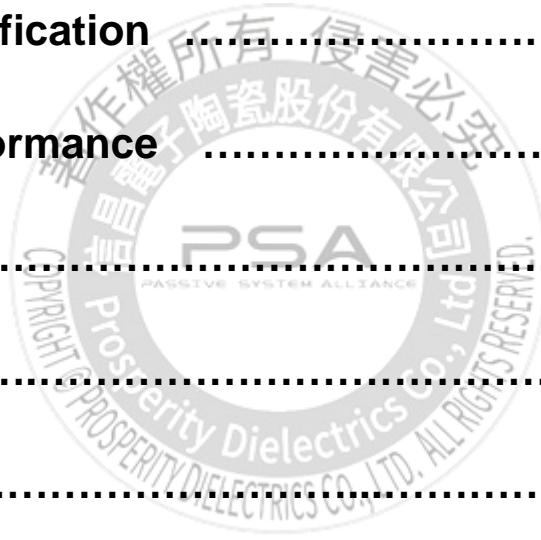

SPECIFICATION FOR APPROVAL

CUSTOMER	CUSTOMER P/N	REV. -	SPL. LOT NO. S202112-0075	
PART NAME MOLDING POWER CHOKE(RoHS+H.F.)	PART NO. MCS1040-XXXMY1	REV. A	DATE OF ISSUE 02/09/'22	Q'TY 0 PCS

ENGINEERING CHANGE NOTICE – RECORD

REVISION NO.	REVISION DESCRIPTION	AUTHOR	DATE	REMARK
A		<i>Jones Weng</i>	2/09/'22	



SPECIFICATION FOR APPROVAL

※This is a RoHS and REACH compliant product whose related documents are available on request.

※Graphic is only for dimensionally application.

1. PART NUMBERING IDENTIFICATION

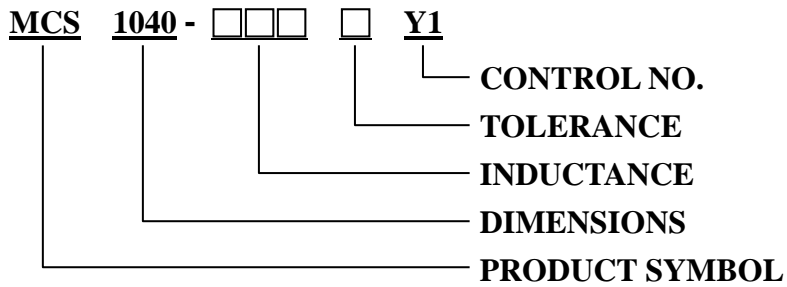

2. MECHANICAL DIMENSION

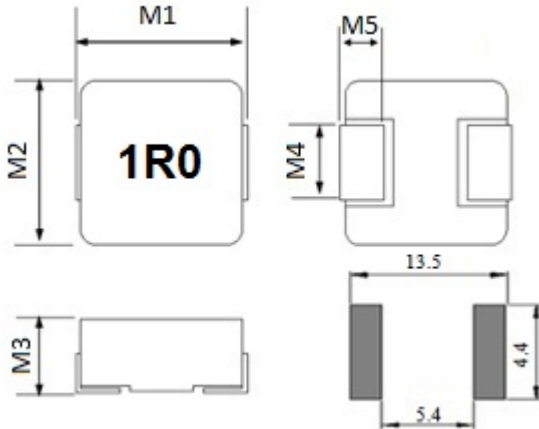

UNIT: mm

	DIM.	TOL.
M1	11.15	±0.35
M2	10.0	±0.3
M3	4.0	MAX.
M4	3.0	±0.5
M5	2.0	±0.5

3. MARKING

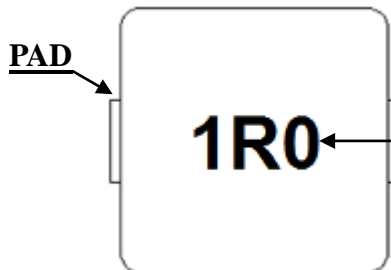

3-1. Marking Direction: On the left and right of PAD, font facing up.

3-2. ex: 1R0 Stands for Marking → 1.0μH

SPECIFICATION FOR APPROVAL

4. ELECTRICAL SPECIFICATION

Part number	Inductance (uH) ±20%	DC Resistance (mΩ) Typical	DC Resistance (mΩ) MAX.	Rated Current (A) Typical	I sat (A) Typical
MCS1040-R68MY1	0.68	2.4	2.7	22.0	30.0
MCS1040-1R0MY1	1.0	3.0	3.3	18.0	28.0
MCS1040-1R5MY1	1.5	3.8	4.2	16.0	21.0
MCS1040-2R2MY1	2.2	6.7	7.0	12.0	18.0
MCS1040-3R3MY1	3.3	10.8	11.8	10.0	16.0
MCS1040-4R7MY1	4.7	17.0	20.0	8.5	15.0
MCS1040-6R8MY1	6.8	22.5	25.0	6.5	9.0
MCS1040-100MY1	10.0	27.0	30.0	7.5	8.5

TEST INSTRUMENT: Zentech3302 / Zentech16502

NOTE:

1. Test Freq.: 100KHz, 1.0V
2. All test Data is referenced to 25°C ambient.
3. Typical Heat Rating DC Current would cause an approximately ΔT of 40°C.
4. Typical Saturation DC Current would cause Lo to drop approximately 30%.
5. Operation Temperature Range: -25°C ~ +125°C.
6. Storage Temperature Range: -20°C ~ +40°C (<60% R.H.).
7. The Part temperature (ambient +ΔT) should not exceed 125°C under worst case operating conditions.
8. Circuit design, component placement, PWB trace size and thickness, airflow and other cooling provisions all effect the part temperature. Part temperature should be verified in the end application.
9. MSL: Level 1

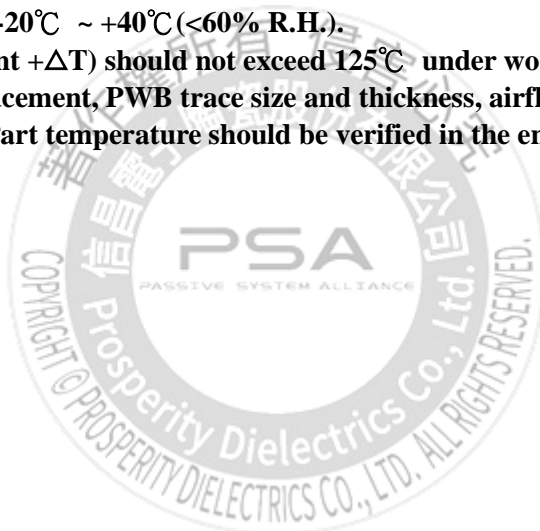

SPECIFICATION FOR APPROVAL

5. RELIABILITY PERFORMANCE

Reliability Experiment For Electrical

Test Item	Accept criteria	Test Condition	Standard Source
Humidity Test	1.Change from an initial value L:within±5% 2.no visible damage.	+40°C± 2°C, humidity of 90% ±5% (total 96 hours).	MIL-STD-202H Method 103 Test Condition B
High Temperature Test	1.Change from an initial value L:within±5% 2.no visible damage.	1.Temperature: +125°C±2°C. 2.Test time: 72±2hrs.	IEC 68-2 Test Condition B
Low Temperature Test	1.Change from an initial value L:within±5% 2.no visible damage.	1.Temperature: -25°C±2°C. 2.Test time: 72±2hrs.	IEC 68-2 Test Condition A
Thermal Shock	1.Change from an initial value L:within±5% 2.no visible damage.	+125°C±5°C (30 minutes) ~ -65±5°C (30 minutes), temperature switch time: 5 minutes (total 50 cycles).	Reference MIL-STD-202H Method 107 Test Condition B-2
Life Test	1.Change from an initial value L:within±5% 2.no visible damage.	+70°C±5°C (250Hours).	Reference MIL-STD-202H Method 108 Test Condition B

Reliability Experiment For Physical

Test Item	Accept criteria	Test Condition	Standard Source
Vibration Test	1.Change from an initial value L:within±5% 2.no visible damage.	10-55-10HZ, amplitude: 1.5mm, direction: X, Y, Z axes, each axis 2 hours (total 6 hours).	MIL-STD-202H Method 201
Solder Heat Resistance Test	1.no visible damage.	IR/convection reflow: Peak Temp 250±5°C for 30±5Sec. in air, Through 3 Cycle. Temperature Ramp:+1~4°C/sec.; Above 183°C, must keep 90 s - 120 s.	Reference MIL-STD-202H Method 210 Test Condition K (Reflow)
Solder Ability Test	1. Lead must have 95% above coverage.	Solder temp: 245±5°C, Immersion time: 5 second. Immersion rate: 25±6mm/sec.	J-STD-002D Test condition B1

SPECIFICATION FOR APPROVAL

6. REFLOW CHART

Typical RoHS Reflow Profile

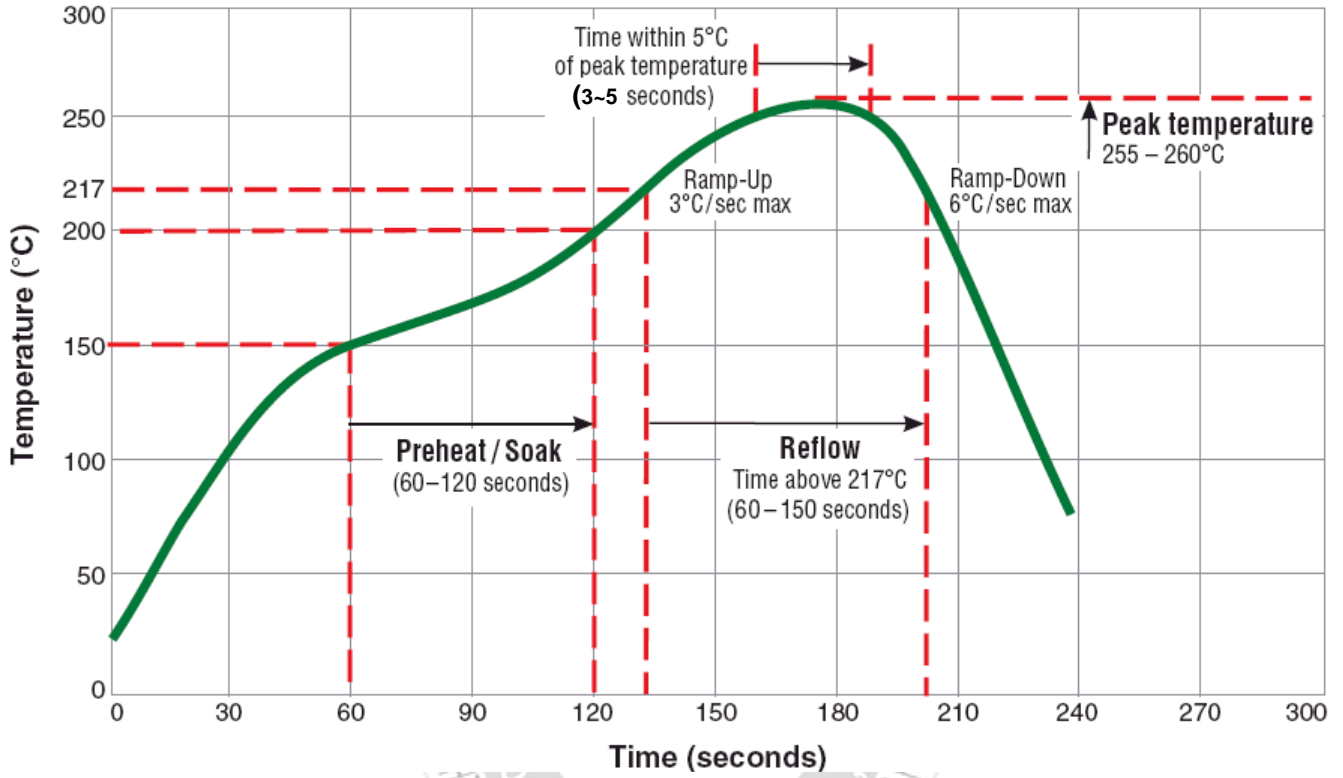

SPECIFICATION FOR APPROVAL

7. PACKING

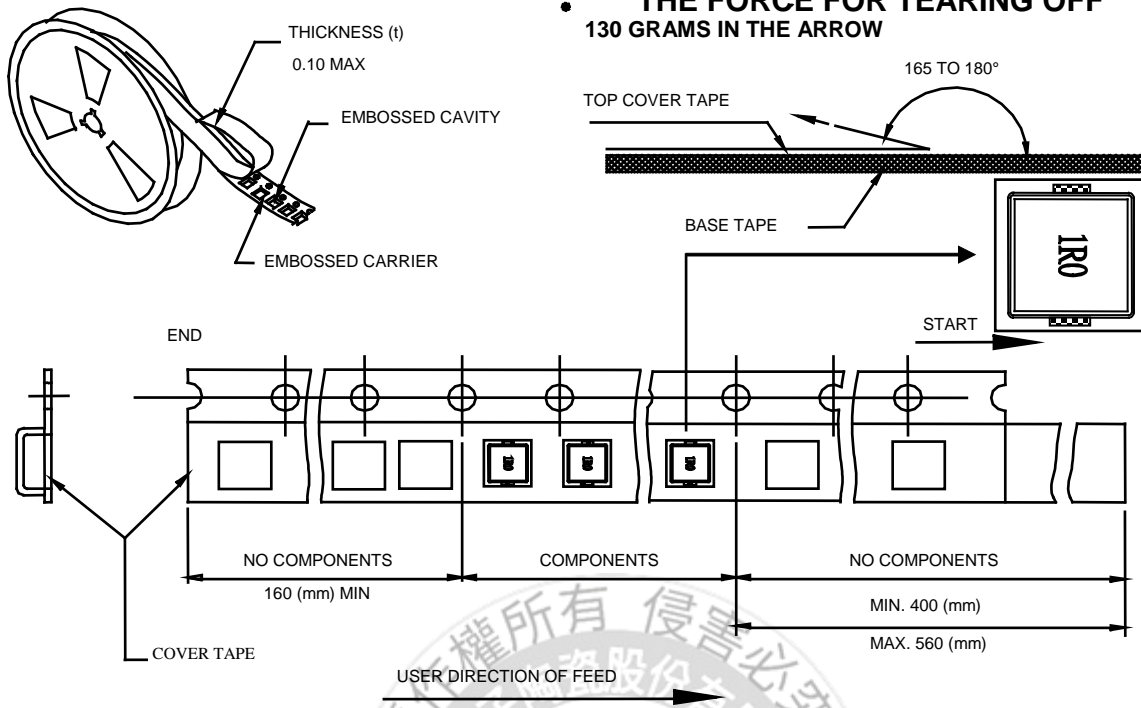

■ CARRIER TAPE REELS (mm)

MATERIAL: PLASTIC

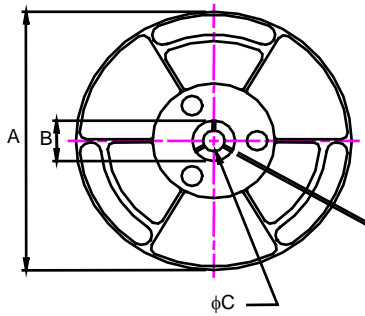

500 Parts per Reel

■ DIMENSIONS OF CARRIER TAPE (mm)

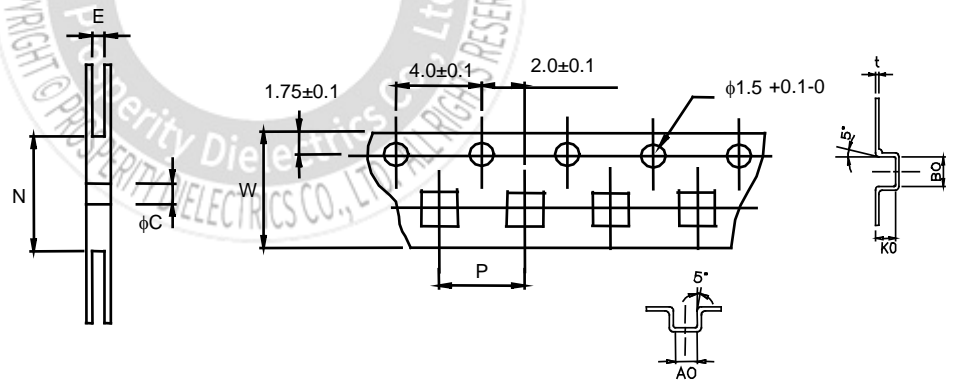

※ 10 sprocket hole pitch cumulative tolerance ± 0.20

UNIT: mm

	A	B	C	E	N	P	W	t	A0	B0	K0
DIM.	330	25.0	13.0	24.6	100	16.0	24.0	0.4	10.6	11.7	4.25
TOL.	± 0.2	± 0.5	± 0.5	± 0.5	MIN	± 0.1	± 0.3	± 0.05	± 0.1	± 0.1	± 0.1

X-ON Electronics

Largest Supplier of Electrical and Electronic Components

Click to view similar products for [Fixed Inductors](#) category:

Click to view products by [Prosperity](#) manufacturer:

Other Similar products are found below :

[CR32NP-100KC](#) [CR54NP-470LC](#) [70F224AI](#) [MGDQ4-00004-P](#) [MHQ1005P10NJ](#) [MHQ1005P1N0S](#) [MHQ1005P2N4S](#) [MHQ1005P3N6S](#)
[MHQ1005P5N1S](#) [MHQ1005P8N2J](#) [PE-53601NL](#) [PE-53602NL](#) [PG0936.113NLT](#) [9220-20](#) [9310-16](#) [PM06-2N7](#) [PM06-39NJ](#) [A01TK](#)
[1206CS-471XJ](#) [HC2-R47-R](#) [HC8-1R2-R](#) [HCF1305-3R3-R](#) [1206CS-151XG](#) [RCH664NP-140L](#) [RCH664NP-4R7M](#) [RCP1317NP-391L](#)
[RCR110DNP-331L](#) [DH2280-4R7M](#) [DS1608C-106](#) [B10TJ](#) [B82498B3101J000](#) [ELJ-RE27NJF2](#) [1812CS-153XJ](#) [1812CS-183XJ](#) [1812CS-](#)
[223XJ](#) [1812LS-104XJ](#) [1812LS-105XJ](#) [1812LS-124XJ](#) [1812LS-154XJ](#) [1812LS-223XJ](#) [1812LS-224XJ](#) [1812LS-563XJ](#) [1812LS-683XJ](#)
[1812LS-824XJ](#) [NIN-FB101JTR110F](#) [NIN-FB471JTR62F](#) [NIN-FC1R5JTR220F](#) [NIN-HCR15JTRF](#) [NIN-HCR33JTRF](#) [NIN-HDR22JTRF](#)