

# PROXXON

**TOOLS WITH CHARACTER!**

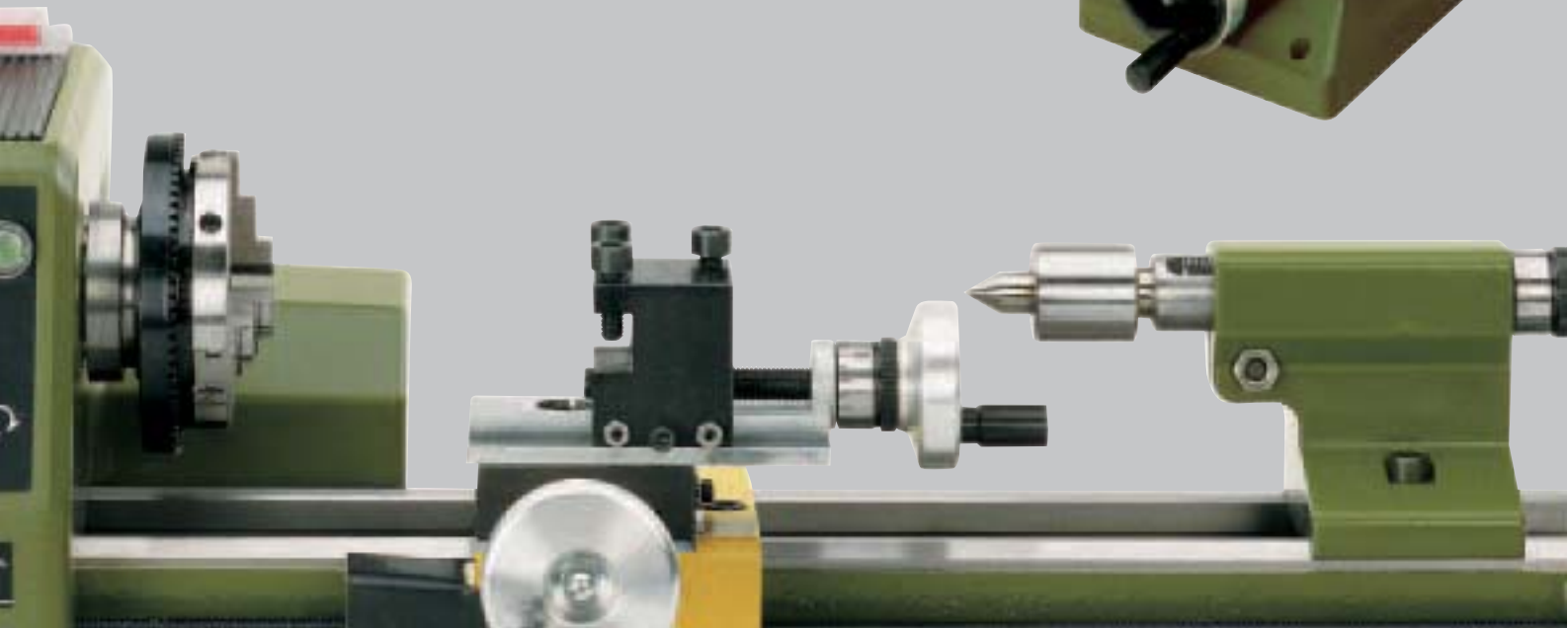

**2006**  
*Updated Edition*  
*With PROXXON System News*



## Welcome

To any professional working with electronic hand and power tool - PROXXON means advanced, competitive, high quality technology. PROXXON individually test each product as it leaves the factory to ensure it arrives with you in immaculate condition.

Further information, log on  
[www.proxxon.com](http://www.proxxon.com)

[The drill/grinder shown here is not included]



## Tile cutting attachment **FEX**

**Complete with tungsten carbide cutter.**  
**Ideal for smaller cuts in wall tiles, wood and plaster of paris.**

The 20mm neck collar allows the rapid connection of the drill/grinder FBS 240/E, MICROMOT 50 and 50/E and the professional drill/grinder IB/E. The clever, stable construction of fibre reinforced POLYAMIDE allows height adjustment, a clear scale as well as a flattened edge allowing one to work close to edges.

No 28 756

Complete with 3.2mm rasp cutter

### **Spare cutter for the FEX**

Rasp cutter of tungsten vanadium with shaft of 3.2mm. Ideal for wall tiles.  
No 28 757



*The versatile mighty mini! Precision Drill/Grinder FBS 240/E:  
The quiet powerhouse with keyless chuck 0.3 – 3.2 mm.*

## **Precision Drill/Grinder FBS 240/E**

1001 uses for every conceivable operation: milling, drilling, grinding, polishing, brushing, cleaning, de-rusting, sawing, carving, engraving, etc. The maximum speed of 20,000rpm is continuously variable down to 5,000rpm. The full wave electronic speed control results in virtually constant torque, even at lower speeds, in turn facilitating micro drilling. The spindle runs in a precision ball bearing and is fitted with a lock button. The 20mm collar fits MICROMOT drill stands and vices. The machine is fitted with a quality, balanced, low noise motor with high life expectancy. Stable housing of POLYAMIDE with soft components in the finger grip area. Complete with 40 quality inserts in a sturdy plastic case.

### **Technical data:**

5,000 - 20,000rpm. Maximum power consumption 100W, 230V, keyless chuck with 0.3 – 3.2mm capacity. Length 185mm and mass 450g. Insulated according to class 2 requirements.

No 28 472



Stable housing of POLYAMIDE with soft components in the finger grip area.

**NOTE:**  
The FBS 240/E may also be fitted with the optional MICROMOT steel collets (see page 20).

Complete with 43 high quality bits and cutters in a durable plastic case.

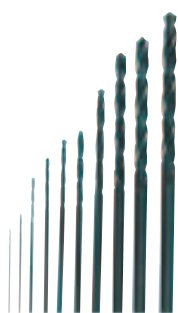



*Miniature precision machines, genuine single handed use.  
Lightweight tools with die-cast aluminium heads:  
quiet, precise and efficient.*



## Professional drill/grinder IB/E

- Usable for prolonged periods when drilling, milling, grinding, polishing, cleaning, cutting and even engraving.
- Ideal for mechanics, model builders, jewellers, opticians, artists and electronic enthusiasts.

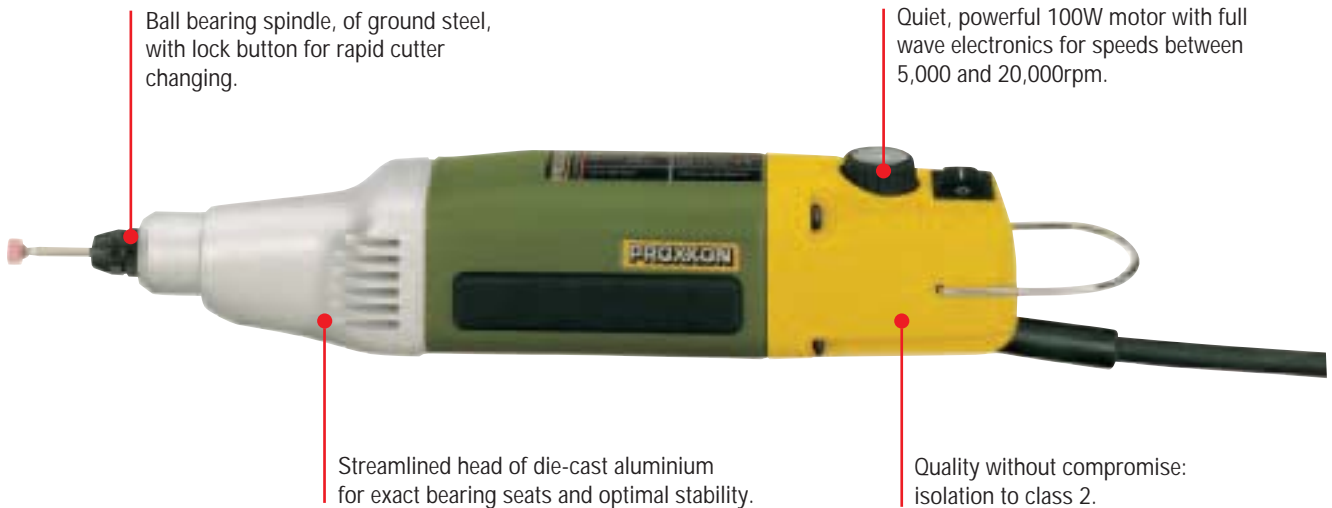

With 34 bits & cutters of industrial quality, all shafts 2.35mm. Complete with six triple slit steel collets covering 1.0 to 3.2 mm (see also page 20).

### High concentric accuracy (maximum runout 3/100mm).

This high-revving, special motor has full-wave electronic speed control for speeds between 5,000 and 20,000rpm and is usable for extended periods at a time. The ground steel spindle runs in a ball bearing, minimising play.

#### Technical data:

Speed 5,000 to 20,000rpm. Power consumption (max) 100W, 220 – 240V. Stable head of die-cast alu and POLYAMIDE main housing. Length 230mm, and weight approx 500g. Insulated to class 2. The 20mm collar allows fitting of optional drill stands, horizontal stands, etc. Supplied with 34 bits and cutters in a stable plastic case.

No 28 481



Six high concentricity collets, (1.0 – 1.5 – 2.0 – 2.4 – 3.0 and 3.2 mm and closure nut).

**NOTE:** MICROMOT steel collets ① They are hardened and thus have a high, consistent flexibility. They also maintain prolonged accuracy, even after regular use (these collets should not be compared with unhardened, four-slit collets of brass and aluminium).

The triple slit collet is ② substantially more difficult to manufacture than the four-slit type, but offers a better load-bearing ③ surface. This is especially important for cutters with small shank diameters.



The IB/E professional drill/grinder, Long neck angle milling/drilling unit WB 220/E and Long neck straight drill/grinder LB/E are supplied in stable plastic cases.



*Weighs in at only 500g and easily drills 5mm mild steel. Ideal for installation, the tool box and work bench.*

## Long neck angle milling/drilling unit MICROMOT WB 220/E

*A slender, low weight right-angled drill for the places you can't always reach.*

220-240  
VOLT



Ideal for milling, drilling, etc. in inaccessible places, e.g. in model ships' hulls, as well as the parting of stock. Special, balanced motor with maximum power input of 100W, full wave electronic speed control.

### Technical Data:

No load speeds of 3,000 – 15,000rpm. Power consumption (max) 100W, 220 – 240V. Stable head of die-cast alu and POLYAMIDE main housing. Length 270mm, and weight approx 550g. Insulated to class 2. Six triple slit, hardened steel collets 1.0 – 1.5 – 2.0 – 2.4 – 3.0 and 3.2mm and closure nut are included. Packed in stable plastic case.  
No 28 492

## MICROMOT quick-change (QC) sanding system

*Sand with different grits of sandpaper. The PROXXON system is far easier to use than the method that uses glued sandpaper.*



Removal is effected by turning the disk CCW while locking the spindle.

### Spare sanding discs for the MICROMOT QC system (ø 25mm)

#### Aluminium Oxide (for steel)

No 28 786	40 grit	5 off
No 28 787	80 grit	5 off
No 28 788	180 grit	5 off

#### Zircon corundum (for stainless and alloy steels)

No 28 789	50 grit	5 off
No 28 790	80 grit	5 off
No 28 791	120 grit	5 off

#### Polishing fleece (for cleaning & finishing)

No 28 792	coarse	5 off
No 28 793	fine	5 off
No 28 794	extra fine	5 off



The quick change adapter fits the long neck angle milling/drilling unit WB 220/E, long neck straight drill/grinder LB/E, professional drill/grinder IB/E, the precision drill/grinders FBS 240/E and FBS 12/E as well as the mill/drill units MM 50 and MM 50/E. Three aluminium oxide discs (grits 40, 80 and 180) for steel, three Zircon-corundum discs (50, 80 and 120 grits) for stainless and alloy steels, as well as three polishing fleeces for cleaning, finishing, and removal of paints (in extra fine, fine and coarse) are all included.

No 28 785 Complete set as above

## Long neck straight drill/grinder LB/E

*Head of die-cast alu with 100mm neck and 20mm MICROMOT collar.*

Ideal for use in inaccessible areas. Mill, drill, grind, drill, polish operations. The design allows use in slots and channels, ideal for internal cuts. Collets 1.0 – 1.5 – 2.0 – 2.4 – 3.0 and 3.2mm and closure nut are included. Well presented in a plastic case.



### Technical data:

Length 300mm and weight 630g. Other details as per IB/E on page 4.

No 28 485





The long, slim head of die-cast aluminium makes the LWS ideal in numerous applications, even parting.

## Long neck Angle Grinder LWS

A corundum grinding disc of grit 60, a fan sander of grit 100 and a reinforced cutting disc are included.



Features include a special, balanced motor. Used on steel, non-ferrous metals, glass, ceramics and wood too.

### Technical data:

Disc diameter 50mm Ø. Mains voltage 220 – 240V, 50/60Hz, 100W max power consumption. 13,000rpm. Stable head of die-cast alu and POLYAMIDE main housing. Length 280mm, and weight approx 550g. Run down time less than 1 second. Insulated to class 2.

No 28 547



### Corundum grinding disc, 50mm diameter, for LWS

Used for de-burring, grinding, sharpening and de-rusting steel and non-ferrous metals.

No 28 585 (60 grit)

No 28 586 (36 grit)



### Silicon Carbide grinding disc, 50mm diameter, for LWS

Used on glass, stone, ceramics and very hard materials.

No 28 587 (60 grit)



### Fan sander, 50mm diameter, for LWS

Standard corundum for superior stock removal on tempered cast iron, cast iron, stainless steel, non-ferrous metals, wood and plastic.

No 28 590 (100 grit)

No 28 591 (150 grit)



### Corundum bound cutting disc for LWS

With woven reinforcing, ideal for cutting steel, non-ferrous metals, plastic and wood. 50mm diameter, 10mm bore and 1mm thick.

No 28 154



### Backing disc for LWS

Self-adhesive type, for use with sanding discs and sanding fleece.

No 28 548

1 off



### Corundum sanding discs

Self-adhesive type, used on flat and convex surfaces.

No 28 549 80 grit 5 off

No 28 550 120 grit 5 off

No 28 551 180 grit 5 off

No 28 552 240 grit 5 off



### Sanding fleece for LWS

Self-adhesive type, used for cleaning, matting and sanding of steel, stainless steel, non-ferrous metals. Also used for paint removal.

No 28 554 medium 5 off

No 28 555 fine 5 off

## Pocket drilling machine Colt 220/E

Weighs in at only 900g and easily drills 5mm mild steel.

Tough and durable permanent magnet motor drives the planetary gear gearbox. The 20 mm collar facilitates use in MICROMOT drill and horizontal stands. Housing of fibreglass reinforced POLYAMIDE. Handy switch with integral electronic speed control and lock. Super-long power cord of 250mm. The RÖHM chuck offers a range of 0.5 to 6mm. The Colt fits into the leather holster supplied as standard equipment.

### Technical Data:

220 – 240V, 50 – 60Hz, maximum power consumption of 100W. Speed approx. 0-3,000rpm. Chuck capacity 0.5 – 6mm. Capacity in mild steel 5mm. Weighs 900g and isolated to class 2.

No 28 490



Long neck angle grinder LWS, COLT 220/E, belt sander BSL 220/E and super jig saw 230/E are all packed in a sturdy plastic carrying case.



*Precision equipment for cutting. Small and comfortable.  
Die-cast aluminium heads.*

### **Belt sander BSL 220/E**



**220-240  
VOLT**

For shape finishing, mortising, fine polishing (flat surfaces). Also for de-burring metal, paint removal and fine finishing. Head of die-cast aluminium, and full wave electronic speed control. Sanding belt can be changed in a matter of seconds. Complete with 2 off 80 and 2 off 180 grit belts.

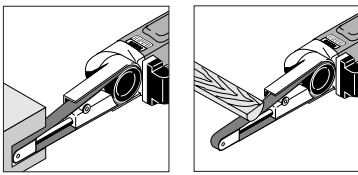

**Technical data:**

Belt size 10 x 330mm and usable sanding area 10 x 110mm. Belt speed electronically controllable from 300 – 700rpm. Mains voltage 220 - 240V. 100W max power consumption. 13,000rpm. Stable head of die-cast alu and POLYAMIDE main housing. Length 350mm, and weight approx 650g. Run down time less than 1 second. Insulated to class 2.  
**No 28 536**

**Replacement corundum sanding belts 10 x 330mm**



on tough, woven backing. Sands metal, non-ferrous metals, wood and plastics efficiently

- No 28 581**      180 grit    set of 5
- No 28 582**      120 grit    set of 5
- No 28 583**      80 grit     set of 5

*The head rotates through 60°.*



### **Super jig saw SS 230/E**



**220-240  
VOLT**

*The alternative 12V jig saw  
STS 12/E is described  
on page 12.*

This unit offers fantastic cutting capacity with footplate adjustable up to 45° for mitre cuts. The housing head is in die-cast aluminium. The stroke speed is variable by means of full wave electronic speed control. Ideal for tight curves in wood (up to 12mm), PC cards and non-ferrous metals to 3mm.

**Technical data:**

Stroke speed of 2,000 – 4,500/min. Mains voltage 220 – 240V, 100W max power consumption. 13,000rpm. Stable head of diecast alu and POLYAMIDE main housing. Length 230mm, and weight approx 700g. Insulated to class 2. Packed in a sturdy plastic case, complete with 4 super cut blades of various pitches for wood, plastic and metal.

**No 28 530**

**Jig saw blades. Special steel.**

Pitch of 1.06mm, teeth ground & set. Usable on hard & soft woods, plywood, fibreglass reinforced sheets as well as various plastics. Ideal for tight curves and clean cuts. Fits SS 230/E and STS 12/E.

- No 28 054**      Pack of 2



**Jig saw blades. HSS**

Tooth pitch of 1.5mm, with teeth set & ground. Usable on metals, aluminium and softer alloys, fibreglass, Plexiglass and insulating materials. Fits SS 230/E and STS 12/E.

- No 28 056**      Pack of 2



*Oscillating motion far better than the conventional orbital motion. Sanding pad oscillates about its centre.*

### Delta sander OZI 220/E

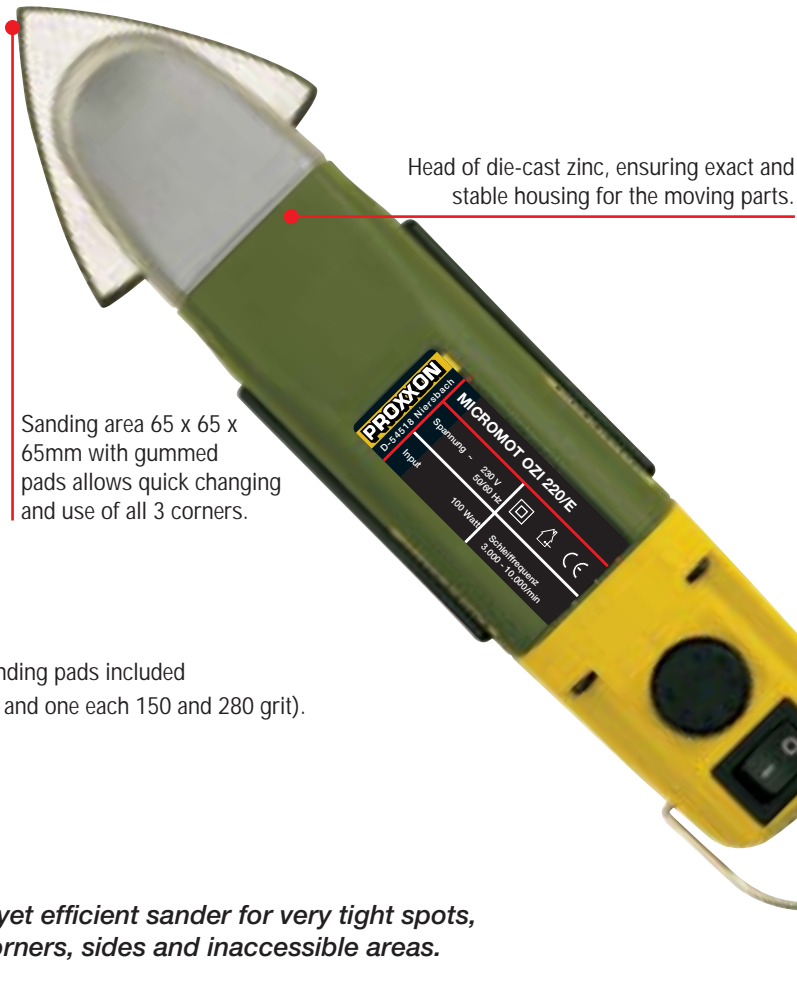

Sanding area 65 x 65 x 65mm with gummed pads allows quick changing and use of all 3 corners.

Head of die-cast zinc, ensuring exact and stable housing for the moving parts.

Four sanding pads included  
(Two 80 and one each 150 and 280 grit).

**Small yet efficient sander for very tight spots, e.g. corners, sides and inaccessible areas.**

The oscillating motion ensures quiet operation and also facilitates cutting. The variable speed between 3,000 and 10,000rpm facility ensures the correct speed for every material.

**IMPORTANT:** The self-adhesive sanding pads ensure quick changing and optimal usage. Simply remove and rotate through 120° for a fresh corner.

### Flexible scraper of spring steel (50 x 70mm)

Utilises the oscillating motion of the OZI, yielding exceptionally high efficiency at 10,000rpm. Ideal for the removal of paint, tile adhesive, silicon removal, and even the removal tar and under-body muck.



No 28 904

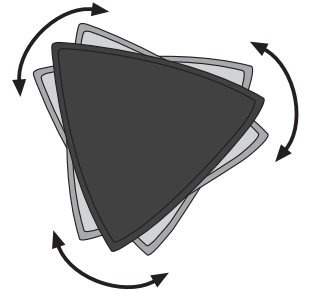

The oscillating motion ensures lack of vibration and kickback and allows the fitting of cutting blades too!



Packed in a sturdy, plastic case, with 4 sanding pads, a sanding fleece and one each hard and soft polishing felt.

No compromise class 2 isolation.

**220-240 VOLT**

#### Technical data:

Sanding shoe size is 65 x 65 x 65mm. Sanding frequency of 3,000 – 10,500rpm. Mains voltage 220 – 240V. 100W max power consumption. Stable head of die-cast alu and POLYAMIDE main housing. Length 230mm, and weight approx 630g. Insulated to class 2.

No 28 520

*Its neat and compact design will have you working where often you will struggle. Here the OZI is using the HSS Blade for precise work.*





**Sanding pads for OZI 220/E**



High durability aluminium oxide pads. Grain filled with special filler to prevent premature clogging and deposited on special backing paper. Self-adhesive.

**Standard packing of 5 sheets per packet:**

- No 28 880 grit 80 5 pieces
- No 28 882 grit 150 5 pieces
- No 28 886 grit 280 5 pieces

**Bulk pack contains 25 each of:**

- No 28 891 grit 80 25 pieces
- No 28 893 grit 150 25 pieces
- No 28 895 grit 280 25 pieces

**HSS cutting blade (65mm diameter)**

Oscillates at up to 10,000 strokes per minute, making it ideal for parting in, e.g., the panel-beating industry, wood (model building and house decor), PC cards, plaster of paris, etc. The segment cut facilitates exact cutting right into corners.



No 28 900

**Diamond cutting blade (65mm diameter)**

Operation as described above for the HSS blade. Cuts marble, bricks, dry walling and many other materials in the sanitary and electrical fields. The segment cut facilitates the cutting right into corners.



No 28 902

**MICRO router MOF**

**220-240 VOLT**

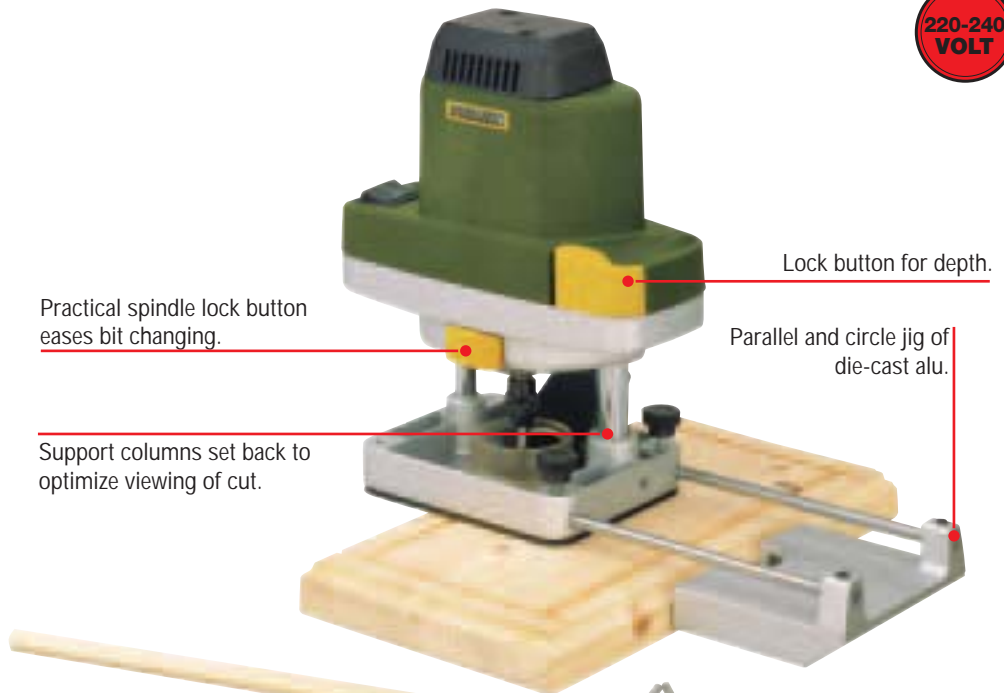

Practical spindle lock button eases bit changing.

Lock button for depth.

Parallel and circle jig of die-cast alu.

Support columns set back to optimize viewing of cut.

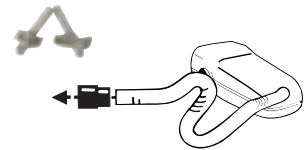

The MICRO router MOF is fitted with a vacuum cleaner or dust extractor adapter, for use in a dust-free environment.

**Base of die-cast alloy and face of smooth gliding POLYCARBONATE.**

Ideal for slotting, rounding over, counter boring, and stock removal in wood, plastic, Perspex, MDF, ceilings and many more.

Supplied with MICROMOT collets 1.0 – 1.5 – 2.0 – 2.4 – 3.0 and 3.2mm and closure nut.

**Technical data:**

Runs at 27,500rpm (no load). Mains voltage 220 – 240V, 130W max. Footprint 70 x 100mm. Milling depth up to 20mm. Insulated to class 2.

No 28 568



**NOTE:**  
Router cutters for wood are detailed on page 34.

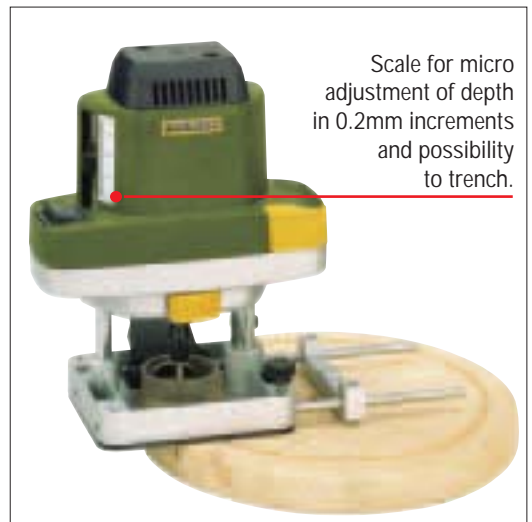

Scale for micro adjustment of depth in 0.2mm increments and possibility to trench.

**NOTE:**  
We recommend our vacuum cleaner controller AS/E on page 31.



## Precision milling/drilling machines MICROMOT 50 and 50/E: Ball bearing spindle and efficient cooling system for extended use.

### MICROMOT 50 and 50/E



- 1001 uses: milling, drilling, routing, de-scaling, polishing, cutting, cleaning, sawing, engraving, etc.
- Useable on any workable material e.g. steel, precious metals, glass, ceramics, plastics, precious stones, etc.
- Ideal for electronic hobbyists, model builders, tool and die makers, jewellers, opticians, artists, chiropractors, dental technicians, etc.
- 12V supply allows the safe use of coolant, e.g. when grinding and cutting semi-precious stones.



**The tens of thousands of these units in use speak for themselves: they are a joy to use. Here is why they are so loved:**

*The diameter of only 35mm makes it easy to handle. The weight of 230g, quietness and effortless drive via the special motor, ground spindle and collar bearing all contribute to the ergonomic design. The high quality steel collets (see page 4) ensure accurate clamping of the cutters. The size of the machine dictates a 12V drive system, use of a transformer is thus required. MICROMOT transformers of at least 1A are recommended.*

### Mill/drill unit MICROMOT 50/E

The thyristor electronic speed control enables the selection of speeds from 5,000 to 20,000rpm. Phase angle control and feedback effect circuits yield high torques, even at low speeds. Six MICROMOT collets for shanks covering 1.0 – 1.5 – 2.0 – 2.4 – 3.0 and 3.2mm are supplied. Power consumption is 40W max. Length 220mm and weight approx. 230g.

No 28 510

### Mill/drill unit MICROMOT 50

As 50/E, except that no speed control is fitted. No load speed is 20,000 rpm.

No 28 500

### Footswitch FS

Frees one's hands for easy operation. For all machines with a Euro plug, class 2 insulation and maximum of 500W. Ideal for both portable and stationary machines. Housing of fibreglass reinforced NYLON. The connecting cord is 250cm in length and the output cord 50cm. The transformer is connected to the FS when using 12V machines.



No 28 700



*Two complete MICROMOT kits: mains adapter, mill/grinder MICROMOT 50/E and 34 cutters.*

### **Model building and engraving set**

With MICROMOT drill/grinder 50/E as described on page 10. Includes 34 industrial quality cutters: 1 diamond grinding bit, 1 fine miller, 0.5 and 1.0mm micro-drills, 1 brass brush, 4 carborundum grinding bits (cylinder, sphere, disc and cone shaped), 1 saw blade, 4 grinding wheels 22 x 3.0mm (2 carborundum, 2 silicon carbide), 20 cutting discs, 1 arbor. The 6 MICROMOT collets described on page 20 are also included. With mains adapter for 220 – 240V operation (12V, 1.0A).

No 28 515

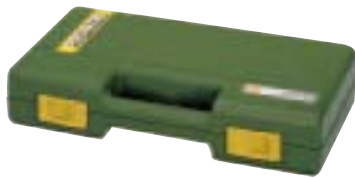

Both sets are packed in an attractive plastic case, with 34 industrial quality cutters.

### **Complete set for detailed work**

The complete set includes drill/mill tool MICROMOT 50/E, drill stand, triple ball bearing flexible shaft 100/P and a suitable mains adapter (220V supply, output 12V at 1.0A). 34 industrial quality bits: 1 diamond grinding bit, 1 fine milling bit, 0.5 and 1.0mm micro-drills, 1 brass brush, 4 carborundum grinding bits (cylinder, ball, wheel, cone), 1 saw blade, 4 grinding wheels (2 silicon carbide, 2 carborundum), 20 cutting discs and arbor. The 6 hardened steel collets fit both the MICROMOT 50/E and flexible shaft. Supplied in a gift case.

No 28 514



### **MICROMOT angle adapter WS 90**



Facilitates working in otherwise difficult areas. May also be used for parting metal profiles such as model railroad tracks. The rubber discs (28 982) convert your machine into an angle grinder. Standard with the 20mm MICROMOT collar and accepts all MICROMOT collets.

**Technical Data:**

Transmission ratio 1:1. Double bearings at input and output ends. Housing of fiberglass reinforced POLYAMIDE.

No 28 405

**NOTE:**

*Quality, triple slit hardened steel collets are ideal for optimum concentricity and tightening force.*

*Furthermore, bits and cutters may be fitted close to the machine.*

*This is especially important when sanding, routing and milling as side play is minimised.*

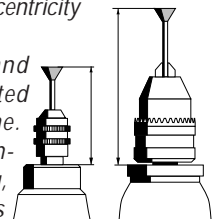



*Pensander PS12 sands linearly where space is at a premium.*

### **Pensander PS 12**



Ideal for working on surfaces in recesses, slots and small corners. Linear stroke of 8,000 per minute, 2.5 mm stroke length. Housing of fiberglass reinforced POLYAMIDE. Four sanding arbours with straight shanks and four angled (all different shapes) as well as three sheets of pre-profiled self-adhesive sanding pads are included. The sheets are of grits 180, 240 and 400 with 5 of each shape per sheet.

No 28 594

#### **Additional Sandpaper for the PS 12**

Three sheets, each with 20 pads (5 each of the four shapes, self-adhesive)

No 28 822                      grit 180

No 28 824                      grit 240

No 28 826                      grit 400

*Note: A mains adapter of at least 1A at 12-18VDC is required. We recommend PROXXON power supplies NG 2/E or NG 5/E. The electronic speed control on these units allows the selection of different speeds for different applications and materials.*

### **Orbital sander SL12/E**

Shaping, rough and fine sanding of flat surfaces and sides. Flat sanding of primers and finish-polishing. Use on 12VDC (safety voltage) and low speeds allow wet sanding. The easy to use paper clamp allows the use of any sand paper. Sanding area 80 x 58mm has no overhanging parts, allowing sanding into corners.

### **Jig saw STS 12/E**

Easy curved and intricate sawing of wood (up to 10mm), printed circuit cards (up to 3mm) and non-ferrous metal (up to 2.5mm). The powerful 5-pole motor operates off 12 – 18VDC with power consumption up to 100W. The stroke is 6 mm and speed is variable between approx. 2,000 and 5,000 per min. Housing of fiberglass reinforced POLYAMIDE. Includes 2 blades (coarse & fine). We recommend the use of MICROMOT mains adapters of at least 2A/24VA.

No 28 534



Housing of fiberglass reinforced POLYAMIDE. The 100W (max) motor operates off 12 – 18VDC. Stroke speed 1,000 – 5,000 per minute. We recommend the use of MICROMOT mains adapters of at least 2A/24VA.

No 28 542



Jig saw blades can be found on page 7.



*Power and precision also when using coolant.  
Includes keyless chuck (capacity 0.3 - 3.2mm).*

## MICROMOT precision drill grinder FBS 12/E

*Ideal precision tools for delicate jobs that aren't possible with a normal drill: e.g. precision drilling, milling, sanding, polishing, brushing, de-rusting, engraving and cutting.*

Includes keyless chuck (capacity 0.3 – 3.2mm). A precision ball bearing minimises spindle side play. Spindle lock button for bit changing obviates the need for spanners. Recessed spindle head for inserting MICROMOT steel collets (see page 4). Efficient forced ventilation cooling of high quality, 5 pole motor. Fibreglass reinforced POLYAMIDE casing.

### Technical data:

12 – 18VDC, maximum power consumption 100W. Electronic speed control of 3,000 - 15,000rpm. Length 185mm and weight approx. 450g.

Recommended for use with MICROMOT transformers of at least 2.0A (see page 15).

No 28 462



### Load balancer FZ 300

Load capacity 300 – 600g, cord length to 180cm. Housed in a sheet steel case with plastic outer cover. Weight approx. 400g and size approx. 220 x 100 x 40mm. Ideal for assembly lines and work benches.

No 28 699

## MICRO screwdriver MIS 1

*Forget about compressed air! Easy, quiet and environmentally-friendly screw driving. With pre-selectable torques of 0.35 – 2.0Nm. Complete with 16 inserts of Chrome Molybdenum steel.*

The gearbox yields the ideal speed of about 200 – 250rpm (depending on mains adapter used). The clutch, adjustable in the range 0.35 to 1.0Nm in 5 steps. Means tightening torques can be selected precisely. The sixth stage bypasses the clutch and yields approx. 2Nm. An ideally positioned rocker switch provides on/off/reverse. A ROEHM chuck

facilitates acceptance of all bit shanks of up to 6.5mm / 1/4". A set, packed in a cardboard box, also includes 16 inserts of Chrome Molybdenum steel. We recommend the use of MICROMOT mains adaptors.

No 28 690

- ⊖ Slot: 0,3 x 1,5 / 0,35 x 2,0 / 0,4 x 2,5 mm
- ⊕ Phillips: Size 0 and 1
- ⊛ Torx: T 6, T 8, T 10
- ⊙ Allen key, internal: 3,0 - 3,5 - 4,0 - 4,5 - 5,0 mm
- ⊙ Allen key, external: 1,5 - 2,0 and 2,5 mm

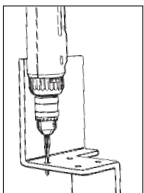

### Recommendation:

*The MICRO screwdriver MIS 1 is eminently suitable to cut threads!*



20mm MICROMOT standard collar.

Efficient forced ventilation cooling for extended periods of use.

High quality, 5 pole motor with high torque.

Speed control with feedback effect for speeds of 3,000 – 15,000rpm.

**NOTE:**  
*The bit holder shown here, usable with bits of 2.35, 3.0 and 3.2 mm is available as NO 28 359 (2 pcs without bits).*



*The complete engraving kit: with trial glass and motifs allowing anyone to start immediately!*

### **Complete engraving kit with „trial glass“**

Complete engraving kit with „trial glass“, supplied with the tried and tested engraving tool GG 12 (12 – 18V, 20,000rpm spindle speed, fitted with ball bearing), TÜV approved mains adapter (12V, 0.5A), motifs and instruction booklet as well as all necessary bits: 1.0 and 1.8mm diamond grinding bits with spherical head for engraving and line work, silicon carbide grinding bits in both conical and bullet shape for frosting glass as well as carborundum grinding bits in ball and cylinder shape for grinding and engraving. Every component is securely packed in an attractive plastic case and bit holder is included for.

No 28 635

### **Engraving tool GG 12, 12 Volt**

Available individually, includes one diamond bit (1.8mm spherical head).

No 28 592



**12 VOLT**

Supplied in durable plastic case.

### **Flexishaft MICROMOT 110/P with triple ball bearings, up to 25,000rpm.**



Two ball bearings in the turned, light aluminium hand piece and one in the drive end prevent tool bit chatter. The highly flexible shroud and core effortlessly transmit power without heating up when bent tightly. Antikink springs at the grip and drive end prevent kinks. Six MICROMOT collets 1.0 – 1.5 – 2.0 – 2.4 – 3.0 and 3.2mm are supplied.

The UHV shown is described on page 17.

No 28 620



**MICROMOT mains adaptors: safe and efficient power sources for hand operated 12 Volt PROXXON machines.**

### **MICROMOT mains adaptor NG 2/E**



**NOTE:**

Power consumption of portable machine tools is measured according to the internationally accepted ICE-745-1 specification. The current drawn is measured, not the power consumption with a hot motor just before stalling. In practice, this condition seldom appears, if ever. All PROXXON mains adaptors are suitably dimensioned for the recommended purposes. Adaptors do not include drill.

Very compact design. NORYL casing (heat resistant -a necessity for transformer enclosures). Capacity 2,0A at 16 Volt open circuit - and 12 Volt under load = 24VA (DC). Primary supply 220 – 240V. Polarised socket for MICROMOT plug. Red LED indicates readiness for use. PTC (Positive temperature coefficient) element prevents overload (and plugged in tool will not automatically restart). After cooling down, the mains plug should be disconnected briefly to reset the adaptor. Modern design with holes for storing bits. Foldable tool rest provides a secure place for keeping the MICROMOT tool at the ready.

Thyristor electronic speed control (with feedback) for adjusting bit speed to suit the job, as well as providing high torque at low speeds.  
No 28 707

### **MICROMOT mains adaptor NG 2/S**

Exactly as above, without electronic speed control. For 220 - 240V.  
No 28 706

### **MICROMOT mains adaptor NG 5/E**

In compact NORYL casing (recommended for transformers). With superior capacity of 5A at 16V no load and 12 Volt under load = 60 VA (DC). Primary supply 220 – 240V. Thyristor electronic control (with feedback) for optimum tool speed and high torque at low speeds.

Three polarised sockets for MICROMOT machines. A pair of sockets for standard banana plugs (4mm diameter) is also supplied. Master switch for turning off the transformer without needing to unplug. Red LED indicates „ready“.

PTC protection against overload (plugged in machine will not restart automatically. After cooling down, the mains plug should briefly be unplugged to reset the adapter).

Practical design with storage holes for tools with 2.35mm and 3mm shafts. Foldable tool rest – keeps the MICROMOT tool being used safely on standby.

No 28 704



## **MICRO compound table KT 70**

Made of solid aluminium with surface treatment and fitted with adjustable dovetail gibs and three T-slots of the MICROMOT standard (12 x 6 x 5mm). Adjustable ruler eases workpiece positioning. Both handwheels have zero-resettable dials with graduations indicating 1 revolution = 1.0mm and 1 division = 0.05mm. The clamps and securing bolts for the MB 140/S and TBM are included.

### **General details:**

Table size 200 x 70mm. X travel 134mm and Y travel 46mm, maximum height 43mm.

No 27 100

### **Step clamps made of steel**

The step clamps set is supplied with the KT 70, but can also be ordered separately. Set consists of 2 ea. stepped blocks and clamps, T-slot nuts of the MICROMOT standard (11.5 x 11 x 4mm), bolts. This set also fits the mill/lathe systems PD 230/E and PD 400.

No 24 256

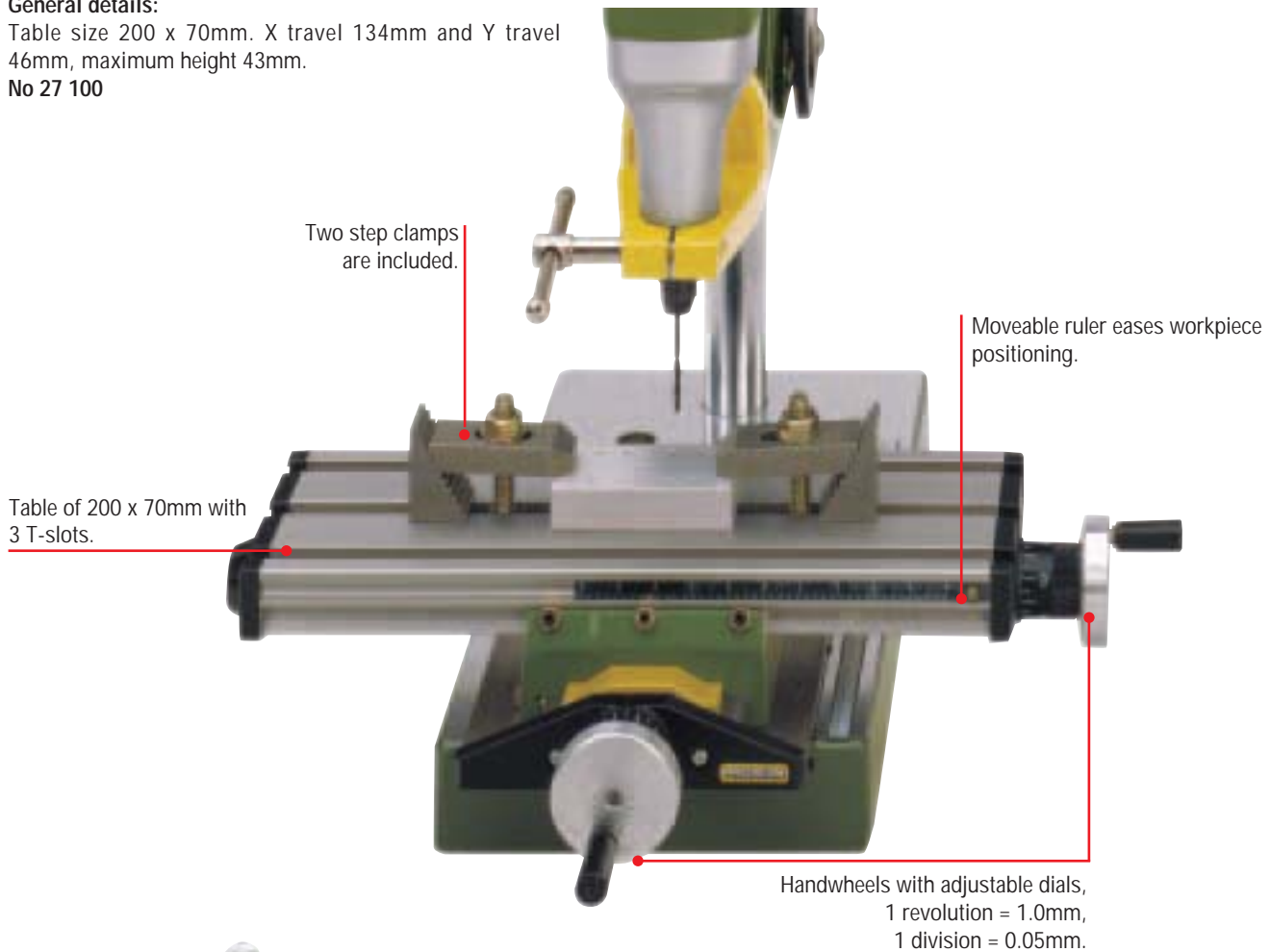

## **Precision vise FMZ With integral clamp.**

Easily clamps to workbenches and tables of up to 60mm. Alternatively, use 2 standard screws to secure to the work surface. Zinc die-casting with ball and socket: rotates in all directions (even downwards). 75mm jaws with protective covers (for delicate workpieces). Jaws also with vertical and horizontal V-slots for clamping round workpieces. Maximum clamping width 70mm and weight 1.6kg.

No 28 608

## **Precision vise FMS 75**

As detailed above, but without clamp. A strong suction cup facilitates instantaneous fixing to any smooth, flat surface.

No 28 602





*The MB 140/S offers fine feed via the drive disc and ball-bearing drive.*

## **MICROMOT drill stand MB 140/S**

The 120 x 220mm table is milled and fitted with a fence and scale. The solid column is chrome plated. The headstock is of die-cast aluminium, offering a throat capacity of 140mm and 30mm travel. A chromed feed lever operates via drive disc and ball bearing system, offering a sensitive feed set-up. T-bars allow simple height adjustment as well as the fixing of the mill drill in the 20mm bore fitting.



The mill drill collar, with scale, tilts through 90° in both directions.

A depth stop as well as drilled, tapped holes for securing the KT 70 compound table and holes to fix the MBS itself are also provided.

No 28 606

### **NOTE**

*Our technicians prefer the use of aluminium as it is clean and stable. All fittings and feeds are machined on our ultra-modern CNC machines, i.e. milling, turning, etc. Pure precision!*

## **Machine Vice MS 4**

Die-cast zinc with three machined sides. The slot fits the adjustable fence of the drill stand MB 140/S and bench drill TBM 220. Horizontal and vertical V-slots in jaw. Jaw width 50mm and height 10mm. Maximum clamping width 34mm.

No 28 132



## **MICROMOT universal holder UHV.**

*The suction food ensures rapid fixing to smooth surfaces.*



The ball joint may be swivelled in all directions. The 20mm bore accepts all MICROMOT machines, e.g. FBS 240/E, 1B/E, MICROMOT 50, 50/E, FBS 12/E.

No 28 603

## **Universal holder UHZ**

Easily clamps to workbenches and tables of up to 60mm. Alternatively, use 2 standard screws to secure to the work surface. Zinc die-casting with ball and socket: rotates in all directions (even downwards). Other details as for the UHV.

No 28 610



# Bits and cutters for MICROMOT drills and mills of industrial quality.

## Drills

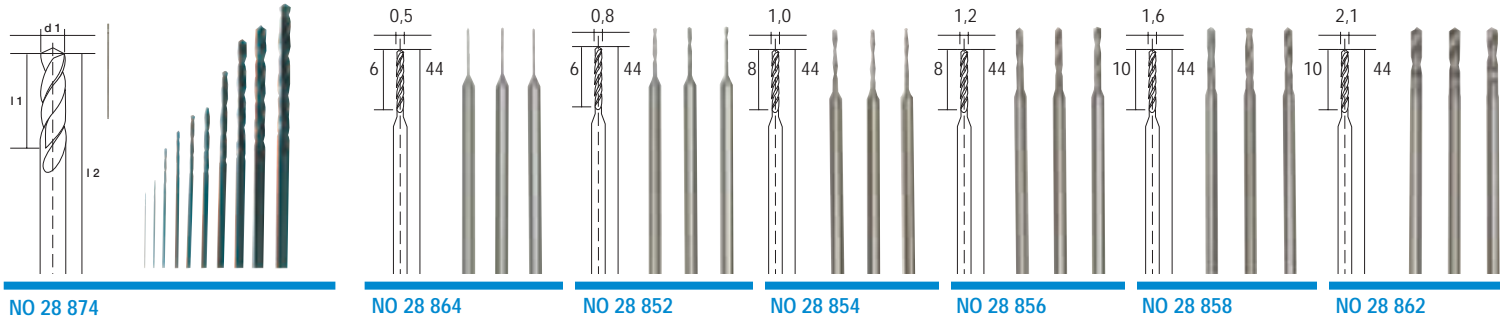

**HSS twist drill set to DIN 338.**  
One each of 0.3 – 0.5 – 0.8 – 1.0 – 1.2 – 1.5 – 2.0 – 2.5 – 3.0 – 3.2mm diameter.

**HSS drill bits**  
Purpose-made, selected, tungsten vanadium steel with high concentricity. Manufactured from a one-piece blank. High hardness for optimum life expectancy. For drilling metal, non-ferrous metals, plastic, PC cards and wood. Work speeds: hard materials approx. 3,000rpm, soft materials approx. 8 000rpm. All shanks 2.35mm.

## Grinding bits

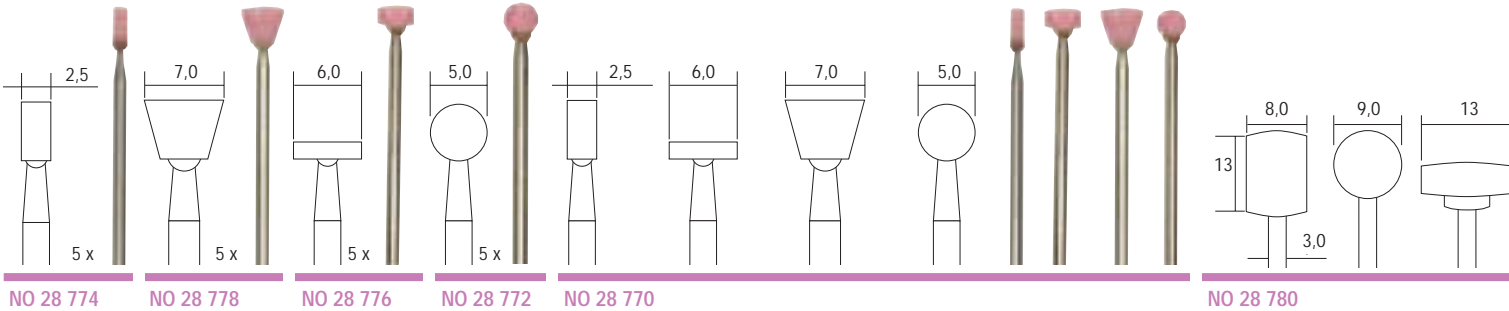

**Carborundum grinding bits**  
High quality bits and sets of quality base materials of consistent hardness. Various shapes for widest possible range of applications. For working especially hard materials such as as well as hard metal alloys. Accurately dimensioned shafts of 2.35 or 3.0mm ensure maximum concentricity.

## Milling bits

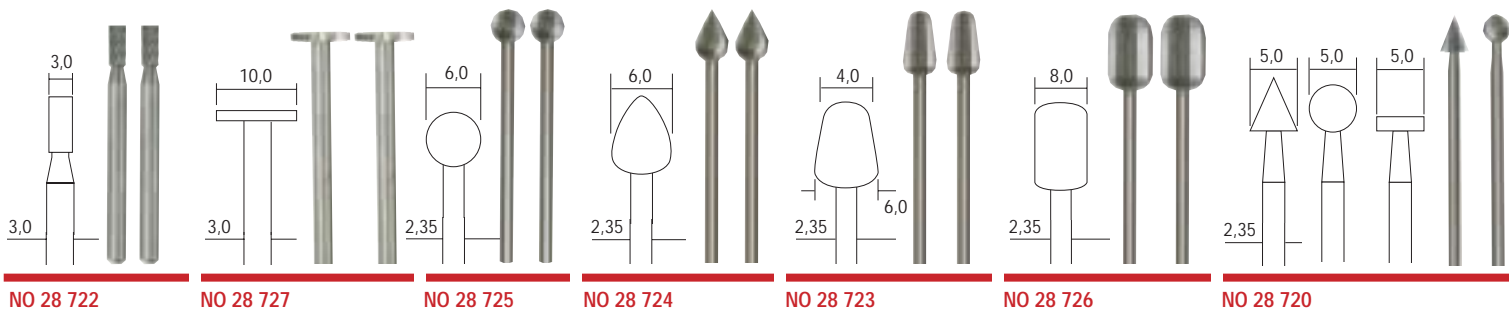

**Tungsten vanadium milling bits**  
Selected tungsten vanadium steel. Purpose made of stable construction with head and shaft out of a single blank. The precise flutes and optimal concentricity ensure best life hard and soft woods, NF and precious metals, as well as plastics and plaster of paris. Ideal for milling, routing, shaping, profiling and slotting.

## Cutting discs

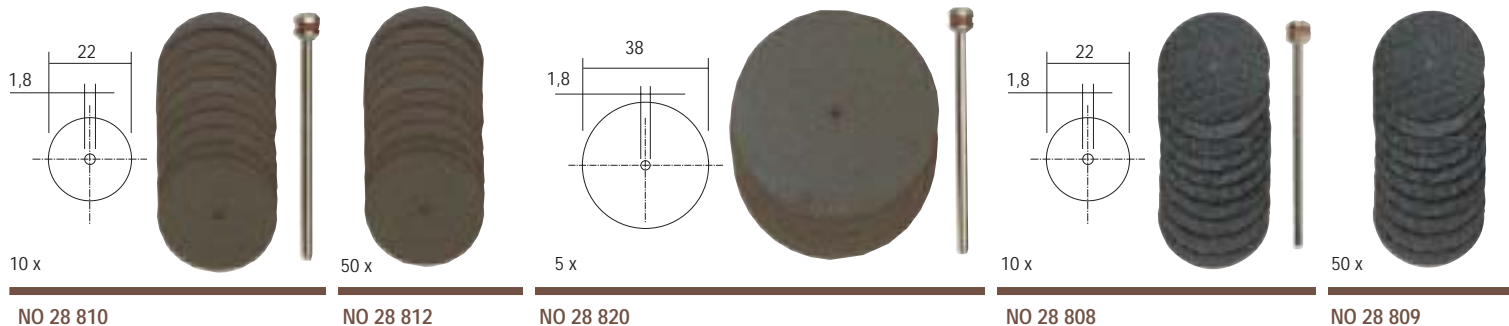

**Corundum discs**  
Discs made of a special compound of diameter 22 or 38 x 0.7mm. Used to part alloys and metals, stainless steels, and NF metals as well as wood and plastics. All arbors 2.35mm.

**Aluminium Oxide with reinforcement**  
The cutting discs are available in 22 x 0.8 and 38 x 1.0mm. Nearly stock. Will cut alloyed, standard and stainless steels, NF metals, Arbor shaft 2.35mm.

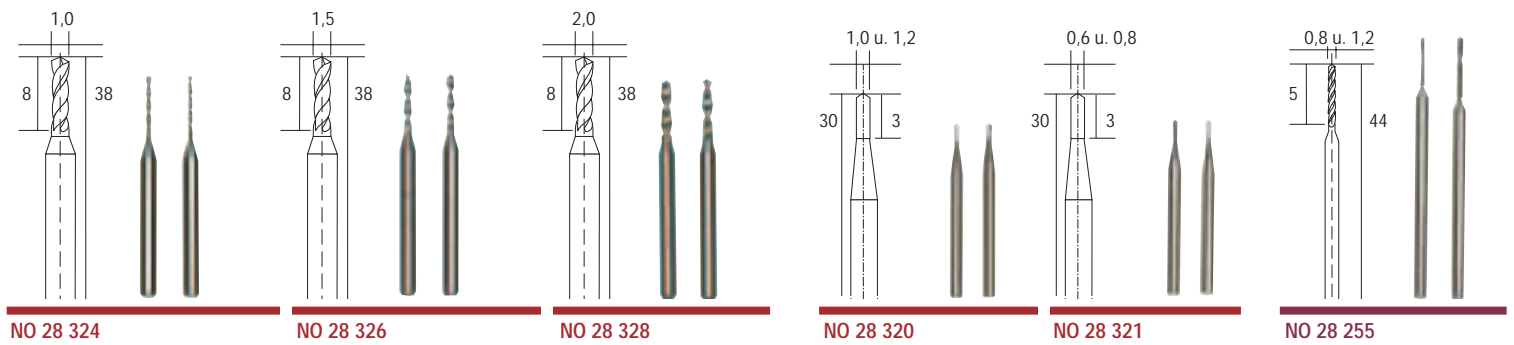

**Hard microdrills**  
 Made of tungsten for optimum lifetime. For drilling glass, semi-precious stones, porcelain, ceramics, marble and other hard stones. With ideal cutting angle of 6°. Shaft of 3mm.

**Tungsten carbide milling drills (Speardrill)**  
 For drilling, milling and cutting fibre glass or PERTINAX circuit boards. Also for drilling pearls and similar. Shaft 2.35mm.

**Diamond twist drills**  
 With natural diamond dust for drilling precious stones (pearls, coral, turquoise). Shafts 2.35mm.

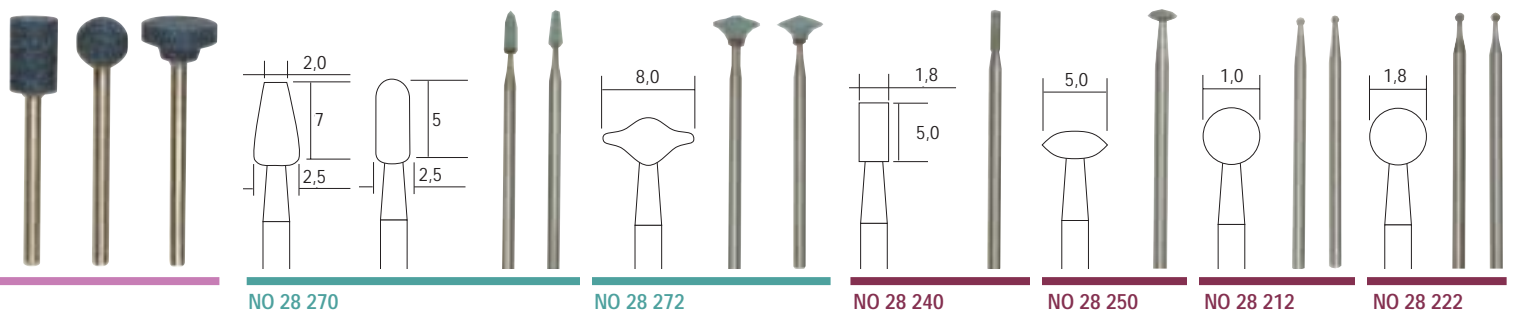

**Silicon carbide grinding bits**  
 cast iron, steel,  
 Fine particles of consistent hardness for engraving and frosting of glass, ceramics and stellites. Also for use on cast steel, cast iron and other hard steels. All shafts 2.35mm.

**Diamond grinding bits**  
 With consistently even coating of diamond dust. Shafts of 2.35mm made from stainless steel. Used for grinding and engraving hard materials: steel (even chrome-cobalt alloy), glass, ceramics, porcelain, plastics.

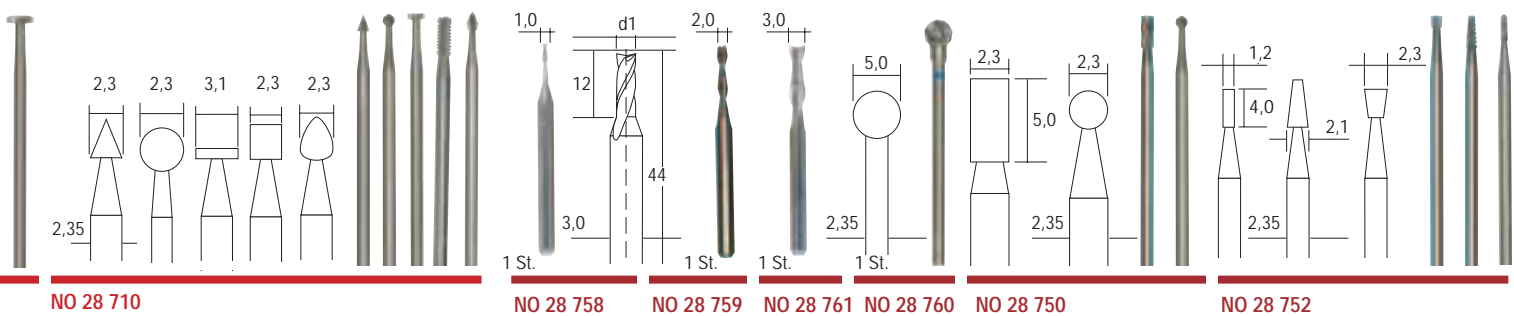

**Tungsten carbide millers**  
 Made of wear-resistant tungsten. Used for vibration-free milling of high accuracy dimensions. It is advisable to secure workpieces well, avoiding accidents. For technical work on extremely hard materials: chrome-cobalt alloy, steel, non-ferrous metals, plastics. May be used for engraving and milling of PC cards.

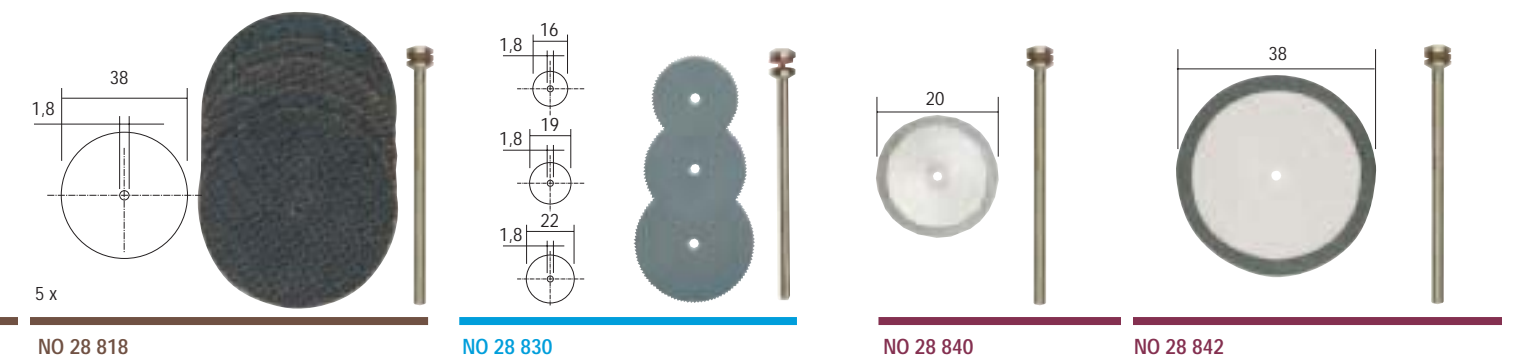

unbreakable, making it usable to remove and even wood and plastics.

**Metal cutting blades**  
 Spring steel, 0.1mm thick. For non-ferrous metals, plastic and wood. Shaft 2.35mm

**Diamond cutting disc**  
 Only 0.6mm thick. For cutting very hard materials such as steel, porcelain, fibreglass, non-ferrous metals. Arbor 2.35mm.

# Selected sanding and polishing bits for all surfaces and longest

## Sanding

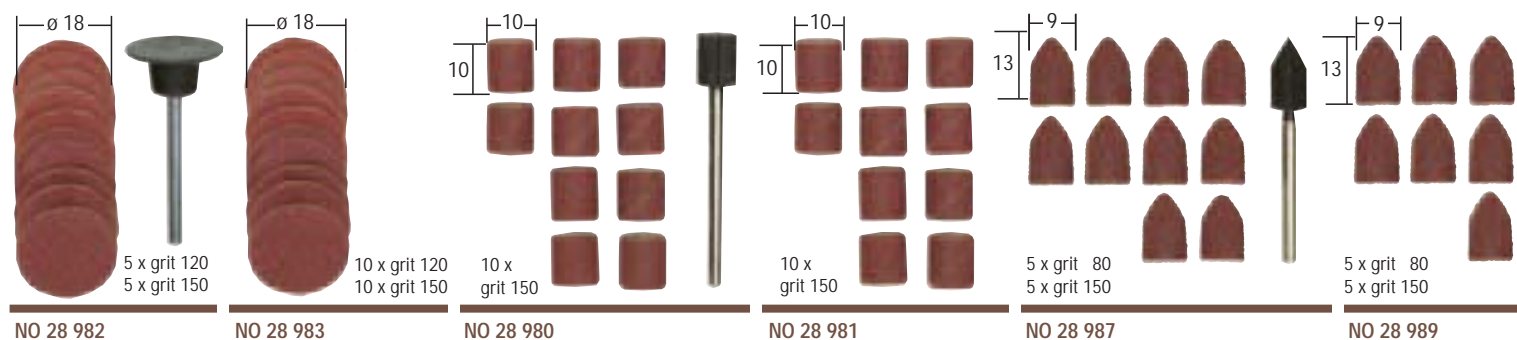

**Sanding discs, drums and wheels** Made of standard compounds of tough consistency and different grits for different sanding stages. With superior lasting characteristics and of various shapes for numerous operations. All shafts 3.0mm. For working steel, non-ferrous metals, plastic, rubber, leather, wood (even edges). Rough grinding of V2A-steel, grinding, welding joints and die-cast aluminium. Ideal for surface and shape sanding.

## Cleaning and polishing

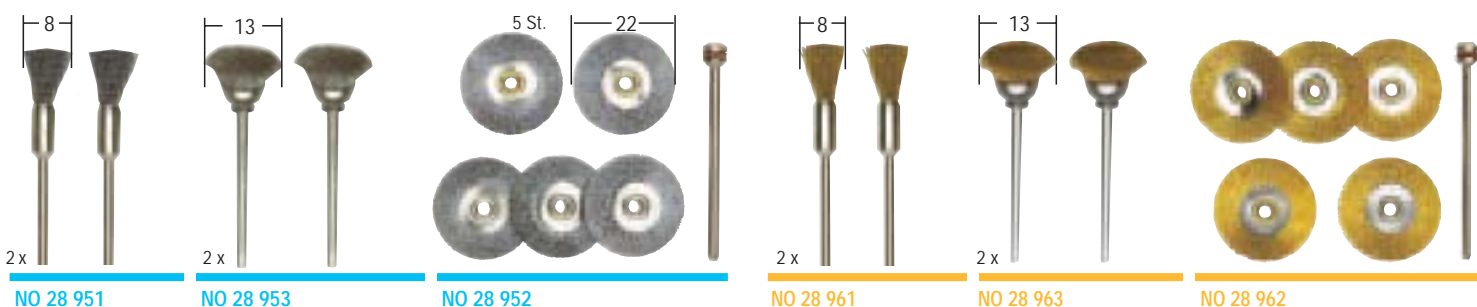

**Steel brushes, cups and wheels** High quality components for best operation. For cleaning, sanding, frosting, rounding-off and fine polishing of metal (incl. non-ferrous), precious metals, plastic, stone and wood. Shafts 2.35mm.

**Brass brushes, cups and wheels** Ideal for working on alloys, copper, precious metals, semi-precious stones, plastic and wood. Acid proof. Electrically neutral, thus suitable for working with electronic components.

## Polishers

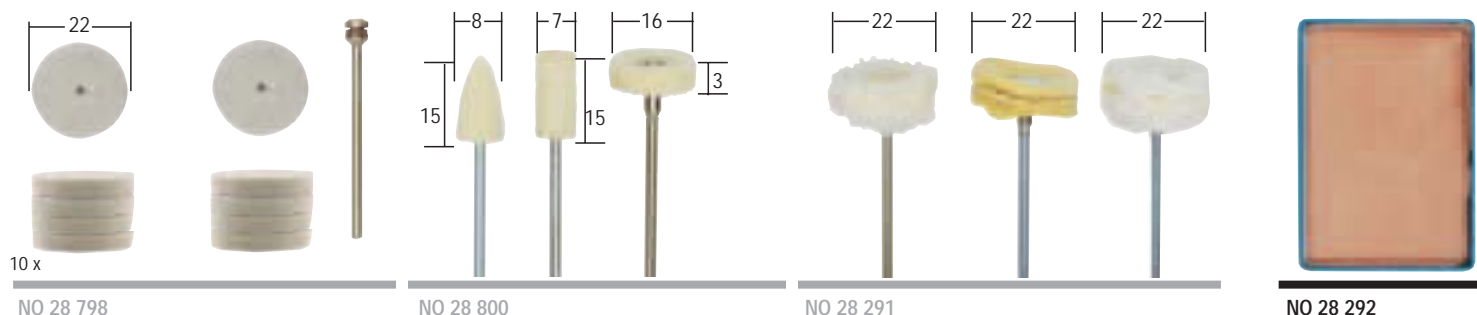

**Felt discs**  
For polishing metal, gold, silver brass and aluminium when using the polishing paste. All shafts 2.35mm.

**Felt Polishers**  
Used on gold and white gold, silver and finishing on tool and die making.

**Cotton, leather and felt polishers**  
For high gloss finishes on metal, gold, silver, non-ferrous metals, aluminium when using polishing paste. 2.35mm shafts.

**Polishing paste**  
Essential for polishing metal and plastic.

## Multiway adapter MF 5 for 12 Volt tools

Fitted with 150cm spiral cable, 4 MICROMOT sockets and one pair of standard 4mm banana sockets. The LED indicates power availability. Mounting holes are provided.

No 28 994



## MICROMOT collets

Fits all MICROMOT machines, excluding the engraver GG 12. One of each 1.0 – 1.5 – 2.0 – 2.4 – 3.0 and 3.2mm, closure nut and holder are included.

No 28 940



## MICROMOT extension cord

The plug and socket are coded to prevent polarity reversal. The 300mm spiral cable may be rolled in a ball for storage purposes and won't tangle.

No 28 992

## Three jaw keyless chuck

Used on all MICROMOT machines, excluding the engraver GG 12, Professional Drill/Grinder IB/E and COLT 220/E. Capacity is 0.5-3.2mm.

No 28 941



# life expectancy!

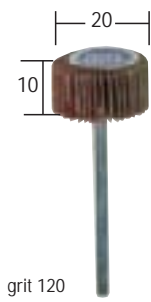

grit 120  
NO 28 984



grit 120  
NO 28 985



NO 28 282



NO 28 302



NO 28 304



NO 28 815

## Flap wheels

These flap wheels are elastic and take on the shape of the workpiece. Ideal for sanding in inaccessible spots. Shaft 3.0mm.

## Nylon fleece brushes

used for cleaning, frosting and sanding steel, precious metal, non-ferrous metals. Shaft 2.35mm.

## Carborundum

Wheels for free-hand and stationary grinding of various metals and materials.

## Silicon carbide

Wheels for free-hand and stationary grinding of various metals and materials.

## Spare arbors

Shaft 2.35 x 44mm.

## Fine polishing

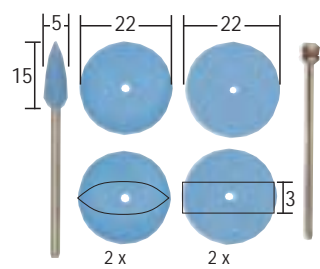

NO 28 290

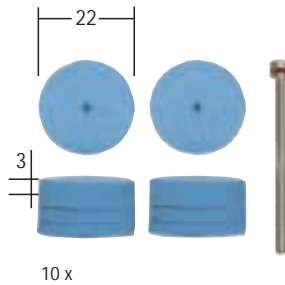

NO 28 294

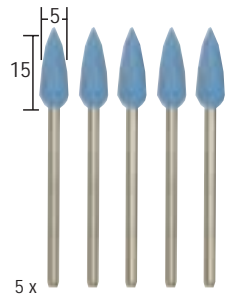

NO 28 288

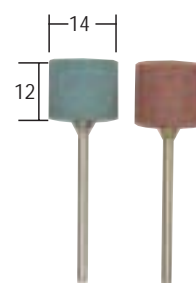

NO 28 295

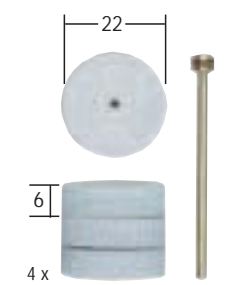

NO 28 296

**Flexible polisher.** Plastic compound, used for surface smoothing and polishing of precious metals, non-ferrous metals, hardened metals as well as glass, porcelain, wood, rubber, plastic. Shaft 2.35mm.

**Flexible polishing pad set of 2.** Silicon carbide in a resilient, flexible compound (no rubber). Especially suitable for working precious metals (gold, platinum, silver) as well as for tool making and castings, and for precision engineering. Shaft 2.35mm.

## Selected sets for many applications!

### Glass working



Four piece set consisting of:  
2 diamond grinding bits and 2 silicon carbide grinding bits. For engraving, grinding and frosting glass. Diamond bit 1: ball  $\phi$  1.0mm, diamond bit 2: ball  $\phi$  1.8mm. Silicon carbide bit cone 3/2 x 5mm and cylinder 2/2.5 x 7mm. All shafts 2.35mm.  
NO 28 920

### Electronic technician set



Nine piece set consisting of:  
1 micro drill each 0.5 – 0.8 – 1.0mm, milling bits ball shape  $\phi$  0.5 and 2.3mm, 3 cutting discs  $\phi$  22mm with arbor.  
For drilling, milling and cutting of PC cards. All shafts 2.35mm.  
NO 28 930

### Jewellery set



Seven piece set for jewellers and goldsmiths.  
Contents: 3 ball milling bits with hole (for milling fittings for pearls etc.) in sizes 3 – 4 and 5mm. 1 double cone miller for milling bases for stones with 1.4mm diameter. 1.0 and 1.4mm millers with concave heads (for rounding off wires etc.). 1.0mm hardened spear drill for pearls and stones included. All shafts 2.35mm.  
NO 28 911

### Modeller's set



13 piece set consisting of:  
1 fine milling bit each ball shape and cylinder 2.3mm, 1 carborundum grinding bit each ball and cone shape 5.0mm. 1 micro drill each 1.0 and 2.3mm. 5 cutting discs  $\phi$  22mm, 1 saw blade  $\phi$  22mm and arbor  $\phi$  2.35mm. For cutting, milling, polishing and drilling. All shafts 2.35mm.  
NO 28 910

### Polishing set



10 piece set consisting of:  
For polishing metal, glass, precious metal, porcelain and plastic. Consists of 3 felt polishing bits (cylinder, cone, wheel). 3 silicon polishing bits (bullet, cylinder and wheel). Cotton wool polishing wheel; chamois buffing wheel and polishing paste (incl. 2.35mm arbor).  
NO 28 285

**Mini compressor MK 230,  
complete with airbrush AB 100**

220-240  
VOLT

**NOTE:**  
The AB 100 is for use  
exclusively with acrylics.



**Mini compressor MK 230**

The set is light, small and quiet. With adapter and 200cm hose to connect to the AB 100, as well as 2 paint containers.

**The single action airbrush AB 100**

is ideal for the beginner. Plastic hand piece with adjustable nozzle.

**Technical data:**

The compressor MK 230 delivers 12 l/minute, maximum pressure of 2 bar. Mains voltage is 220 – 240V, 50/60Hz, 85W. Weight 1.3kg. For airbrush purposes only!

**No 22 600**

**MICROFLAME burner MFB/E**

Used for soldering, de-soldering, brazing, heating of work pieces, tinning. Ideal for model building, electronics, jewellery repairs, dental laboratories, stained glass. Super fine flame shape with temperature attaining 1,300 °C, using butane cartridge, rechargeable with standard lighter fuel.



Fitted with piezo lighter and 50cc cartridge yielding a typical usage of 120min. Independent air and fuel adjustments.

Includes removable foot that ensures stability on the worktop. Weight approx. 250g.

**No 28 146**

**Soldering iron EL 12**

Ideal for working on electronic components. Heating time approx. 10 sec, with ready access to on/off switch, lockable in the „on“ position. PTC technology ensures exact tip temperature of 310 °C, preventing damage to sensitive electronic components such as transistors and ICs, while minimising possibility of generating noxious gases from the solder/flux. Light for illuminating working area. Operates off 12 – 14V DC, including standard power supplies, rated at 1A or more. Complete with spiral cable and standard MICROMOT jack plug.



**Soldering tip**

for EL 12.  
**No 28 141**



*Miniature screwdriver for electronics, cameras, jewellery, mechanics and model builders.*

## MICRO-Screwdrivers

Shafts of high alloy Nickel-Chrome-Molybdenum (SAE 8660) for maximum hardness and toughness. Chromed with brinelled tip. The ergonomically formed plastic handles are oil and impact resistant. The revolving top and finger mould improve ease of use.

- ⊖ Slot: 1,0 x 40, 2,0 x 40, 3,0 x 40
- ⊕ Philips: PH 0 – 3 x 40, PH 0 x 40, PH 1 – 2 x 40
- ⊛ Torx: T 5 x 40, T 6 x 40, T 8 x 40, T 10 x 40, T 15 x 40
- ⊙ Allan key: 1,5 x 40, 2,0 x 40, 2,5 x 40, 3,0 x 40

No 28 148 15 pieces in a stand

Fixed place for each item in the practical holder. May be used as desktop stand or fixed to a wall.



### NOTE:

*It is important to use the MICRO screwdrivers with care and feel. The brute force associated with larger screw-drivers is best left for other tools.*

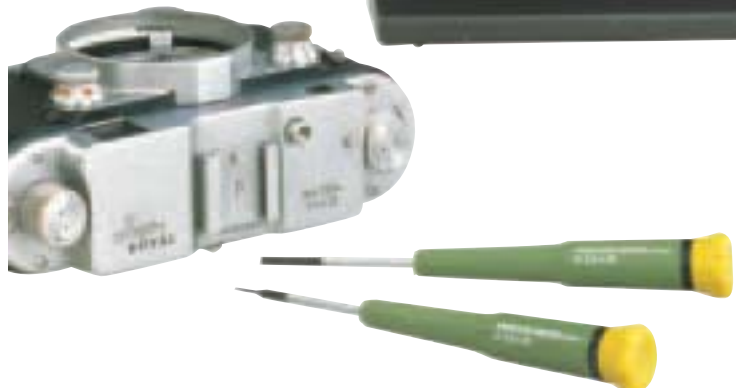

## MICROMOT-glue gun HKP 220

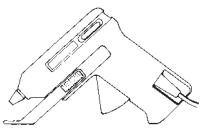

Quick and reliable gluing of metal, wood, plastic (including Plexiglass), glass, ceramics, stoneware, cardboard, leather, polystyrene foams and textiles. The adhesive sets in about 2 min, allowing positional corrections, which is impossible with instant glues.

The 7mm glue sticks are perfect for delicate work such as model building, toy and jewellery making, etc. Sensitive mechanical feed ensures correct glue quantity delivery. Integral stand positions gun on worktop when not in use.

### Technical Data:

220 – 240V. PTC controlled element for exact temperature of 200 °C. Four glue sticks 7x100mm and 3 interchangeable metal nozzles included in the set.

No 28 192



Including 3 interchangeable metal nozzles.

## Replacement glue sticks for HKP 220

12 off transparent 7 x 100mm glue sticks for materials as above.

No 28 194 12 pieces

*A router table for delicate profiles: ideal for model building, picture framing, doll houses and antiques.*



**NOTE:**  
The Drill/Grinder depicted here is not included!



Independently adjustable fence halves means even the profiled or machined section slides securely against the out-feed part of the fence.

### **Router table FT 300**

The table fits all mill/drill units with 20mm collars. The 300 x 180mm table is die-cast in aluminium and supplied with an adjustable, double section fence. The transparent guard prevents accidental contact with the cutter and the mitre gauge slides in a machined slot. The drive unit is fitted under the table in the 20mm collar adapter. Depth of cut is adjustable by means of a knob and the cutter/drive may be tilted through 45°. This facilitates additional profiles without having to purchase numerous cutters. The complete table is secured to the worktop by means of 4 screws. When using the unit occasionally, a plate and 2 clamps should suffice.

**No 28 050**



**NOTE:**  
Router bits for wood, used for picture frames, slots, rounding over radii and others are shown on page 34!

### **MICROMOT router base OFV**

Made from die-cast aluminium, with milled work surfaces. Used to route slots, grooves, edges, and profiles with or without the fence or circle attachment (both supplied). Adjustable depth stop with selectable travel stroke. May also be used as a drill or horizontal stand. Max. width of cut with fence 150mm and circle diameter 100 to 400mm.  
Fits all MICROMOT mill drill units, except GG 12.

**No 28 566**

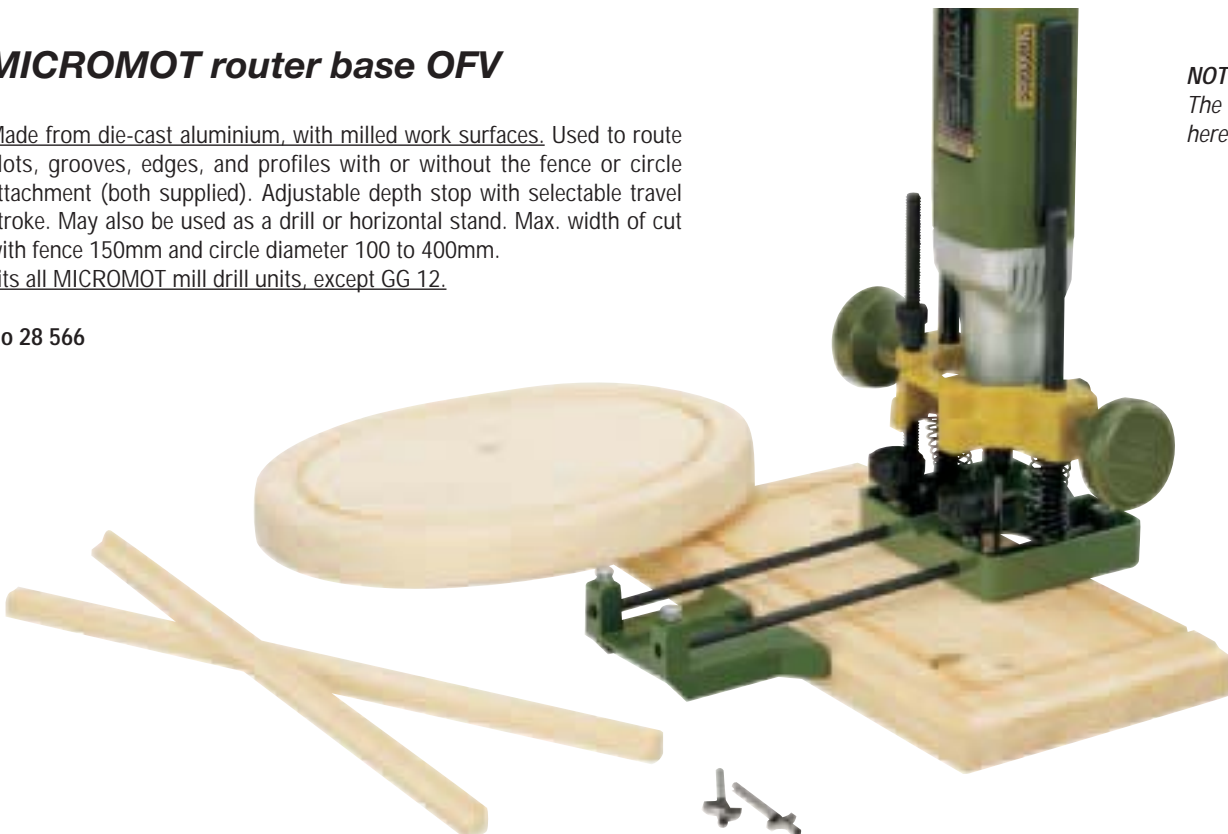

**NOTE:**  
The Drill/Grinder depicted here is not included!



## Motorised carver SGM

220-240  
VOLT

The outline of the workpiece may be sawed with the scroll saw (see pages 29 and 36). Light wood, e.g. jelotong should be used.

Carving with the SGM.

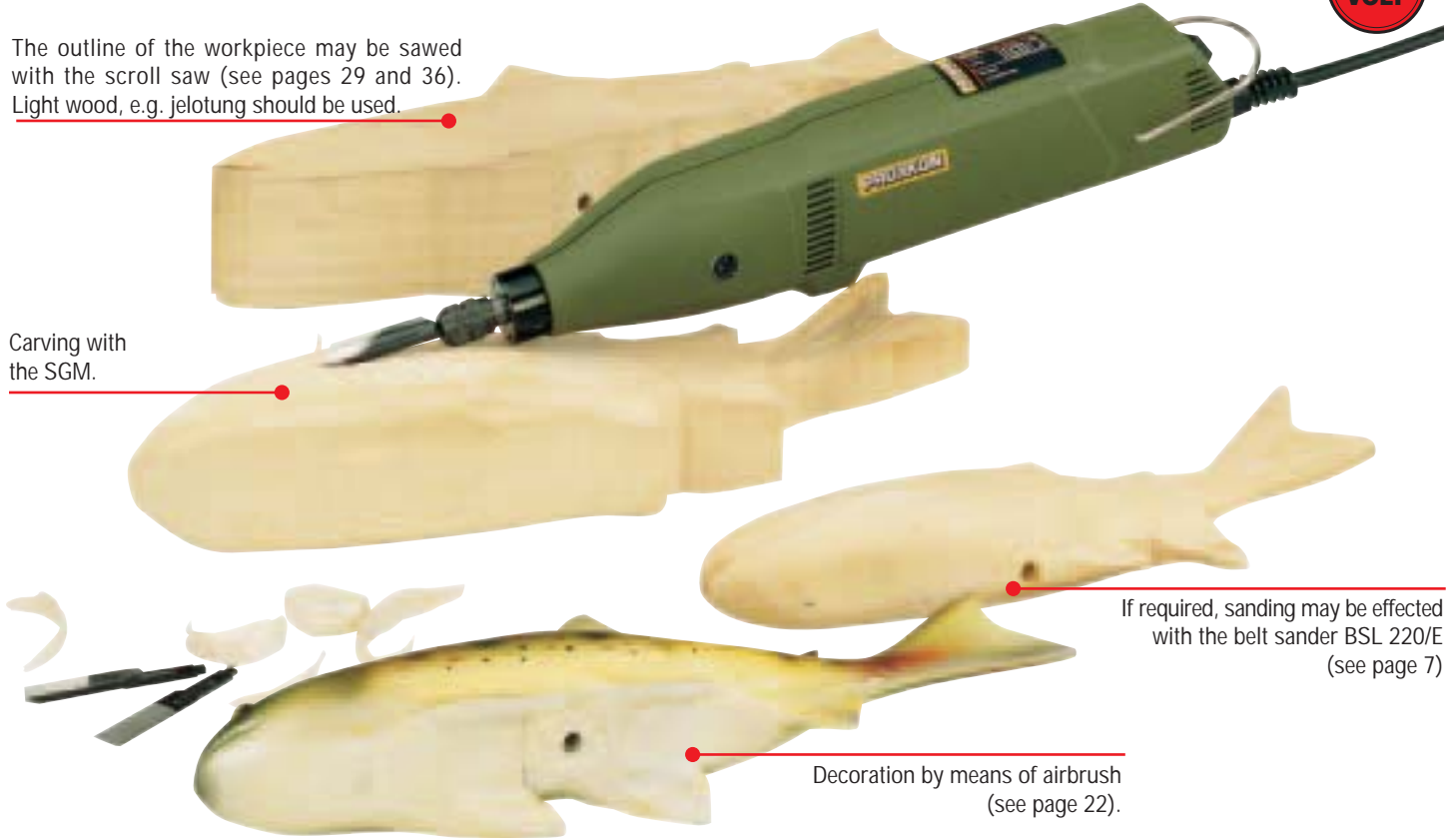

If required, sanding may be effected with the belt sander BSL 220/E (see page 7)

Decoration by means of airbrush (see page 22).

Perfect for carving all wood types, e.g. renovating and working on furniture, reconditioning antiques, lino cutting, delicate paint removal and working plaster of paris. Fibreglass reinforced POLYAMIDE casing. Die-cast aluminium gear housing. Multiple ball bearings and thrust bearing.

### Technical Data:

Powerful motor 220 – 240V (50/60Hz), approx. 65W. 15,000 cuts/min. Includes 3 bi-metallic knives (U, V and flat shapes). Length (without knives) approx. 240mm, weight approx 675g.

No 28 642

## Replacement carving blades

High quality laminated steel (bi-metallic). Knives in V shape, large and small gouge, flat with straight and rounded cutting edge. All 5 to a set.



No 28 572

5 piece set

## Profiled sharpening stone

With pre-profiled surface for sharpening the knives described above. Pure oil stone for a razor sharp cutting edge. Approx. dimensions 100 x 65 x 15mm.



No 28 578

## PROXXON model builder handbook

A5 book of over 270 pages explaining the use of PROXXON tools and bits. Available in German only.

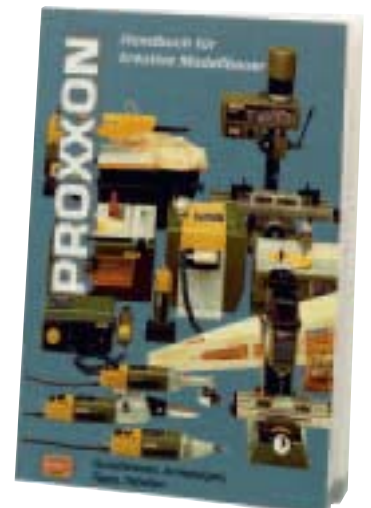

No 28 996



*Centre distance 250mm and 40mm swing.  
Infinitely adjustable speeds covering 1,000 – 5,000rpm.*



## MICRO Woodturning lathe DB 250

*Turning in miniature is a pleasing hobby. One can make glasses, cups, saucers, vases and columns for a doll house. In model trains, one can make lighting*

*masts, windows, tanks. Limbs for marionettes and hundreds of classical miniature turning may be carried out with ease.*



The tool rest is adjustable in all directions, including height. Used here for turning with a face plate (workpiece is fixed with ordinary wooden screws).



Electronic speed control assists in the painting process.

### Technical data:

Centre distance of 250mm, 40mm swing. Motor 220 – 240V, 150W, 50/60Hz. Electronic speed control between 1,000 and 5,000rpm. Tail-stock travel 20mm, total length 400mm.

Includes 6 collets (2 – 3 – 4 – 6 – 8 – 10mm), drive centre, live centre and face plate.

No 27 020



Workpieces are secured by means of collets (1 each of 2 – 3 – 4 – 6 and 8 are included as standard).

Ball bearing spindle is bored through at 10mm.  
For series production of small parts.

Tailstock with quill travel.

Stable tool rest is adjustable in all directions.

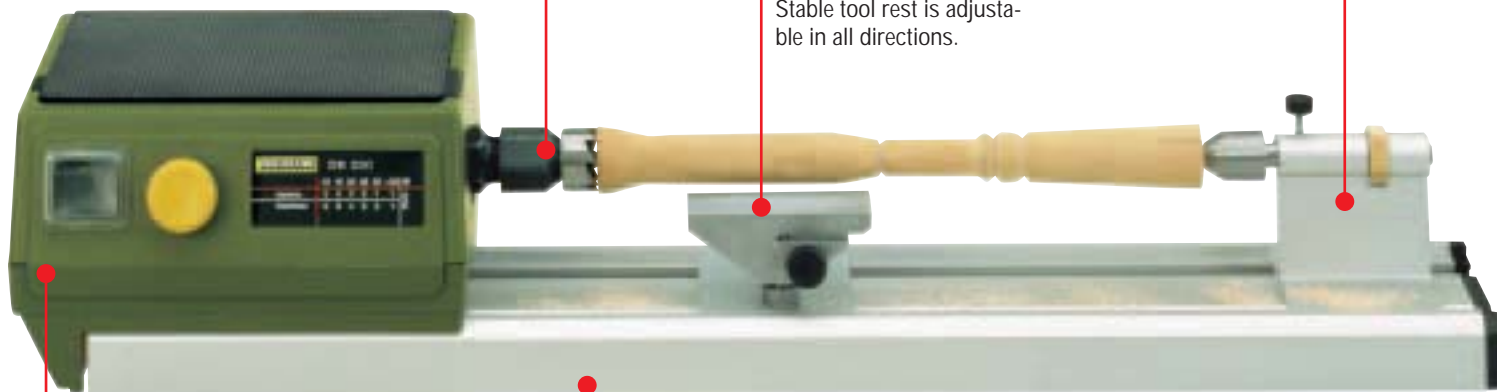

Powerful drive motor with speed control between 1,000 and 5,000rpm.

The bed is made from a stable, thick-walled aluminium profile.

A face plate for turning larger items is included.

### Three piece chisel set

One each of the flat, gouge and parting chisels.  
No 27 022



### Independent four jaw chuck for the DB 250

Used to clamp asymmetrical pieces such as rectangles. The reversible jaws clamp from 0 – 35mm (inside) and 14 – 67mm (outside). The DB 250 headstock spindle of thread M16 x 1 screws directly into the chuck.

No 27 024



### Three jaw chuck for the lathe DB 250 used for concentric clamping.

Made from zinc diecast and offering 1.5 to 32mm and 12 to 65mm when reversing the jaws. The chuck has a M16 x 1 thread for fitting directly to the DB 250 spindle.

No 27 026



**Hot wire cutter THERMOCUT**

**220-240  
VOLT**

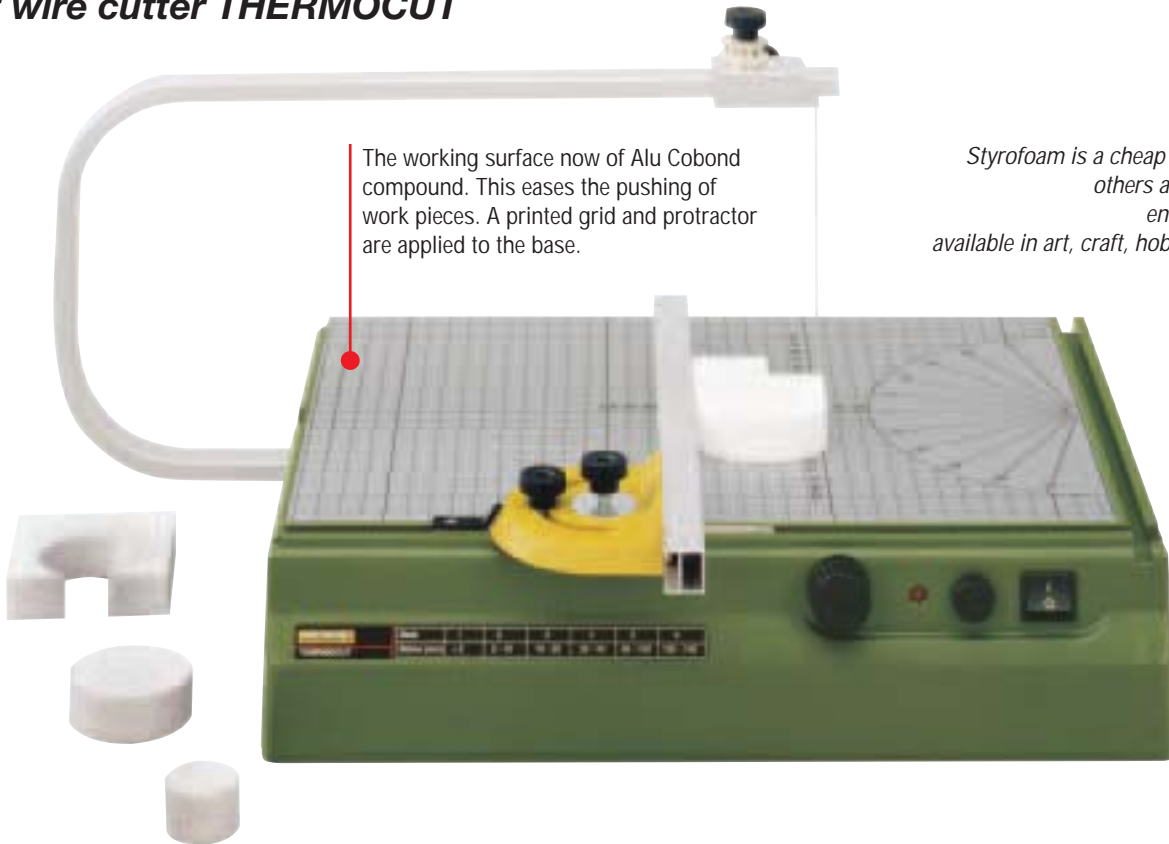

The working surface now of Alu Cobond compound. This eases the pushing of work pieces. A printed grid and protractor are applied to the base.

**NOTE:**  
*Styrofoam is a cheap material compared to others and does not harm the environment. It is easily available in art, craft, hobby and similar shops.*

**Ideal for architectural models, designers, decorators, artists (teaching too), prototypes as well as classical railroad, plane and boat model building.**

**NOTE:** The unit's double wound transformer and insulation to class 2 ensure the cutter is absolutely safe. The cutting wire operates at 10V, 1A. The large base with 390 x 280mm table with surface of Alu cobond compound ensures compound smooth and easy movement of the workpiece. The printed grid and protractor ease division and cutting. Solid aluminium overarm has a 350mm throat and offers 140mm capacity in height. The holder and wire coil (30m, 0.2mm diameter is included) may be shifted along the overarm to enable mitre cutting. A LED indicates operation and prevents burnt fingers (the cutting wire heats to maximum in less than 1 second).

**NOTE:** The correct temperature, being material type and thickness dependent, is learnt from experience. Optimum profiles are cut at lower temperatures and cutting force.

**Technical Data**

220 – 240V, 50/60Hz, insulated to class 2 requirements. Transformer secondary max. 10V, 1A. Cutting wire temperature with 0.2mm diameter is variable between approx. 100 and 200 °C. Weight approx. 3kg.

No 27 080

**Spare cutting wire**

Used on the THERMOCUT and other similar units. Made of NiCr 8020. Spool of 30m x 0.2mm.

No 28 080



Double function fence with lockable feed bar  
(German Patent 100 00 102.5).



Crosscuts are achieved by means of a simple yet efficient solution: Secure drawing-pin to table by means of tape, it serves as a fixed centre.



For perfect straight cuts in wood, non-ferrous metals, plastic and PC cards.

## Bench circular saw KS 230

The 58mm diameter Super Cut blade cuts soft woods up to 8mm, plastics (Pertinax too) to approx. 3mm, non-ferrous metals to approx. 1.5mm. Fibreglass reinforced PC cards could be cut with the tungsten blade.

The 85W, VDE tested motor is quiet, operates off 220 – 240V and has a prolonged life expectancy. The side door allows easy sawdust removal. Overall size approx. 240 x 180 x 80mm. Weight 1.8kg.

No 27 006

### IMPORTANT:

Power transmission by toothed belt via ball bearings, housed in sturdy casing, ensures the right blade speed for the job (approx. 5,000rpm) with a doubling of torque (approx.). Above all, it ensures good cutting depth.

### Diamond blade



50mm diameter (10mm bore). With 0,5mm layer of class „D107“ diamond for cutting ceramics, as well as fibreglass sheets.

No 28 012

**Crosscut blade „super-cut“** 58mm diameter (10mm bore). 80 alternately set teeth. Ideal for hard and soft wood as well as plastic and Pertinax. For fast, clean cuts. Teeth are individually set and sharpened. Superior cutting power!



No 28 014

**Solid carbide saw blade** 50mm diameter (10mm bore) 0.5mm thick. Fine toothed: Ideal for cutting fibreglass sheets, up to 3mm, non-ferrous metals, duro-plastics and other "difficult" materials.



No 28 011

**Spring steel saw blade** 50mm diameter (10 mm bore), fine teeth. Designed for precision cutting.



No 28 020

**Tungsten tipped saw blades** 50mm Ø x 1.1mm (10mm bore). 10 teeth. Used to cut hard and soft woods, PC cards, PERTINAX and Alu.



No 28 016

50mm Ø x 1,1mm (10mm bore). 20 teeth. For extremely clean cuts of balsa, plywood. Can also be used for cutting PC cards and POLYCARBONATE.



No 28 017

### NOTE:

The larger version of the circular saw KS 230 (model FKS/E) is described on page 37.

Super cut blade 58mm dia., 80 teeth, individually set and sharpened, is included.

Adjustable fence with scale.



Graduated mitre stop.

Machined, die-cast aluminium table of 160 x 160mm.

Quiet, high performance 230V motor for prolonged use.

Base of ABS with a sawdust door on the right.

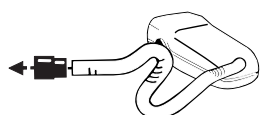

Very important when sawing: use our vacuum cleaner adaptor for a cleaner work environment.

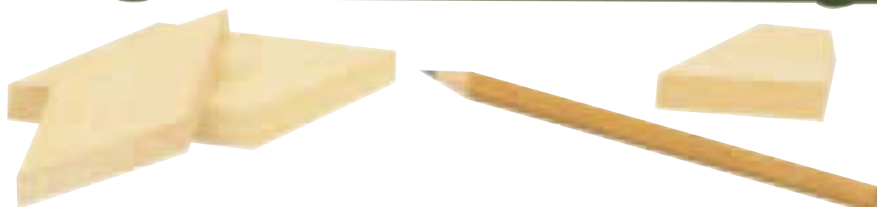
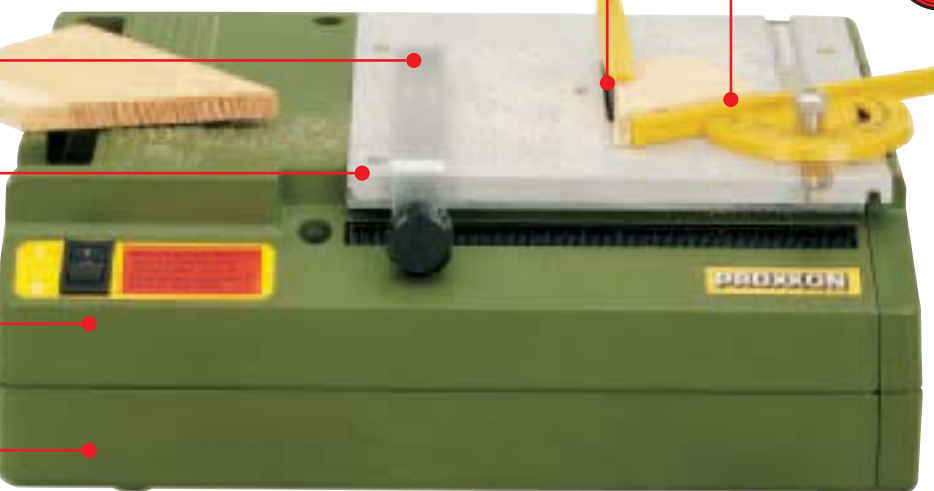



*Cuts aluminium, wood, PC cards and plastics with standard fret saw blades.*

## Scroll saw DS 230/E

Adjustable head (patent EP 09783341) offers numerous advantages (see description below).



**NOTE:**  
Please also see the scroll saw DSH/E (page 36).  
The new blade clamping system enables the use of the saw blades (without pin) described below.

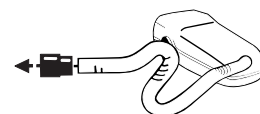
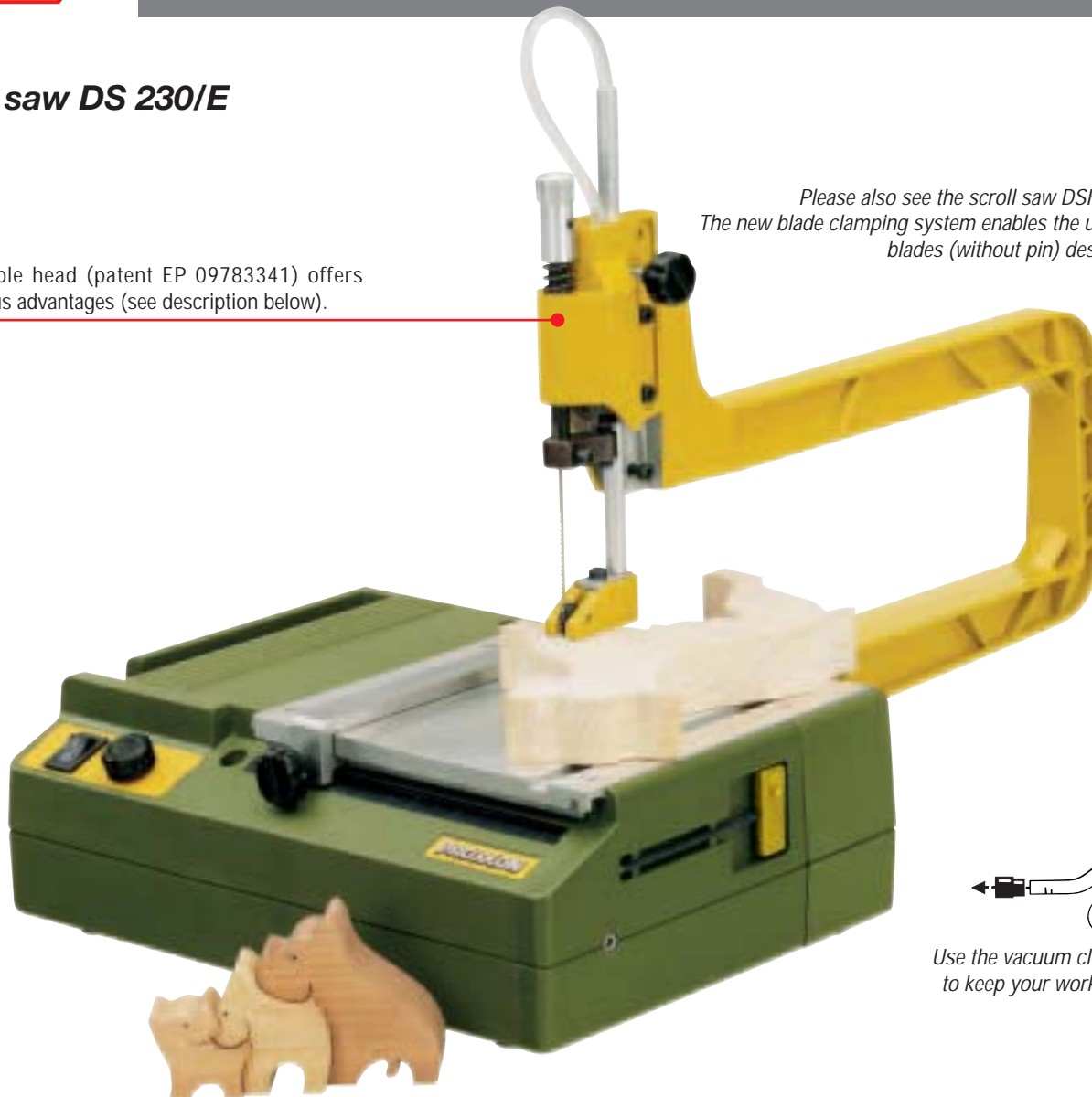

Use the vacuum cleaner adaptor to keep your work area cleaner.

**The ideal machine for that delicate project: model building, toy making and precision work.**

Cuts soft wood (e.g. balsa) up to 40mm, hard wood up to approx. 10mm, plastic (including PC cards) up to approx. 4mm and non-ferrous metals up to 2mm. Very stable ribbed die-cast aluminium saw frame with 300mm throat. Blade guide with integrated blower. Height adjustable head (3 positions).

Blade usage is improved as the head may be lowered in two steps, making new blade teeth available. This effectively triples blade life.

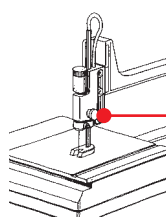

The lowest head position still allows blades, shortened by 60mm, to be used.

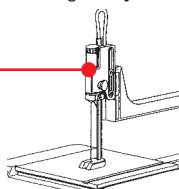

Machined worktable of die-cast aluminium, 160 x 160mm. ABS plastic body with side sliding panel for removal of saw dust. VDE approved 220 – 240V motor (85W) for prolonged, low noise performance. Quiet, wear-resistant toothed belt drive running in a ball bearing. Electronically controllable stroke rate from approx. 150 – 2,500/min. Adjustable fence and mitre stop with scale.

No 27 088

### Super-Cut scroll saw blades

High quality steel for extended use and prolonged cutting capacity in hard and soft woods, plastic, Perspex and soft NF materials. Standard version (without pin).



**Hard and soft woods, plastic, Perspex and soft NF materials.**

#### Set of 6 coarse-toothed blades (14 TPI):

No 28 110 130 x 1.50 x 0.48mm

#### Set of 6 standard-toothed blades (17 TPI):

No 28 108 130 x 1.20 x 0.38mm

#### Set of 6 fine-toothed blades (25 TPI):

No 28 107 130 x 0.77 x 0.30mm

#### Hard materials such as steel and PERTINAX.

#### Set of 6 fine-toothed blades (28 TPI):

No 28 104 130 x 1.10 x 0.50mm

#### Set of 6 very fine-toothed blades (41 TPI):

No 28 106 130 x 0.74 x 0.36mm



For 50mm discs and brushes. With electronic speed control from 8 to 24 m/sec.



## Grinding and Polishing Machine SP/E



Vacuum cleaner adaptor can be used.

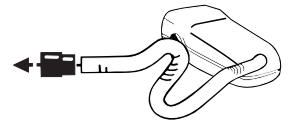

The slim housing facilitates the grinding of long workpieces and includes an adapter to connect a vacuum cleaner to the unit. The tool rests and eye guards are both adjustable. A spindle lock eases the changing of wheels and discs. Supplied with a 50 x 13mm corundum (grade N) and silicon carbide (soft compound) wheel for general grinding/sharpening and hard materials respectively. The right hand spindle accepts the polishing arbor, which is supplied as standard equipment.



### Technical Data:

Variable speed of 3,000 – 9,000rpm, or 8 – 24m/sec with standard wheels. Motor 220 – 240V. Insulated to class 2. Wheels 50 x 13 x 12.7mm. Weight

approx. 1.2kg and size approx. 250 x 130 x 100mm.  
No 28 030

### Polishing set (50mm ø) easily fitted to the arbor.

Steel wire brush for de-rusting and cleaning steel and NF metals. Brass wire brush to polish non-ferrous metals and precious metals. Felt wheel is used on painted surfaces and the chamois and cotton wheels provide a high gloss finish on non-ferrous metals and precious metals.



No 28 312 complete set

### Spare discs for the SP/E and BSG 220 (50 x 13mm)

Corundum (grade N) with 12.7mm bore  
No 28 308

Silicon carbide with 12.7mm bore. Soft compound for very hard materials.  
No 28 310

## Cut off saw KG 50

Accurately cuts small items of metal, wood and plastic.

Table moveable through 45°, allowing mitre cuts. Workpiece is fastened tightly and accurately by means of the integrated clamping device. Clamp jaws 27mm wide and maximum workpiece diameter 20mm. Depth of cut to 13mm. A special slot is provided to clamp HO model tracks. The fence accepts lengths up to 140mm. Five ceramic cutting discs 50 x 1 x 10mm are also included suitable for cutting steel, non-ferrous metals as well as wooden or plastic rods.

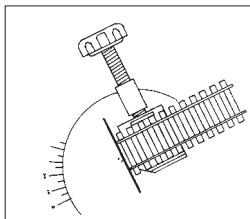

Technical Data: 220 – 240V. 85W. 50/60Hz. Peripheral speed 20m/sec. Weight approx. 1.5kg.

No 27 150

### Replacement cutting discs

Made of ceramic compound: 50% alu oxide and 50% silicon carbide. Suitable for cutting steel, NF metal as well as small wood and ceramic bars.

No 28 152





Easy sharpening of drill bits from 3 to 13mm diameter, standard 118°.

### Drill Sharpener BSG 220



**NOTE:**  
The use of the BSG 220 is quite simple and even allows novices to sharpen drill bits to DIN. However, carefully study the instructions before using the BSG 220 if you wish to sharpen drill bits expertly.

The operation is relatively simple, enabling everybody to sharpen standard 118° HSS, CrV and tungsten bits of 3 - 13mm diameter professionally.

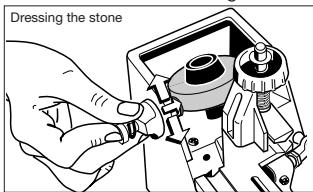

The sharpening operation is controlled exactly by means of the movable carriage. This moves from left to right and also rotates the drill bit on its own axis. This operation yields the correct relief angle. The carriage is fitted with a feed screw for fine feed. A dressing stone, ensuring a sharp cutting surface, is also fitted.

**Technical Data:** Carborundum grinding disc size 50 x 13mm. 220 – 240V, 85W. ABS housing with fixing holes. Weight 1.7kg. An easy to understand operating manual and replacement disc accompany the unit. For further spare discs see page 30.  
No 21 200

### Adapters for sharpening of small drill bits

These adapters extend the BSG 220's range to cover 1.5 – 3mm. One each adapter for sizes 1.5 – 1.6 – 2.0 – 2.4 – 2.5 and 3.0mm. Neatly packed in a wooden box with sliding lid.



No 21 232

### Vacuum cleaner controller AS/E

Switches your dust extractor or vacuum cleaner on and off.

The controller supplies the powertool (either portable or stationary) and vacuum cleaner with power. It switches on the vacuum cleaner while the powertool is operational. Once the powertool is switched off, a 3 second run-down period ensures the workplace is properly vacuumed.

Additional switch positions switch the vacuum cleaner on or off permanently. Usable with powertools of 25 – 500W and vacuum cleaners of up to 1,500W.

No 27 032

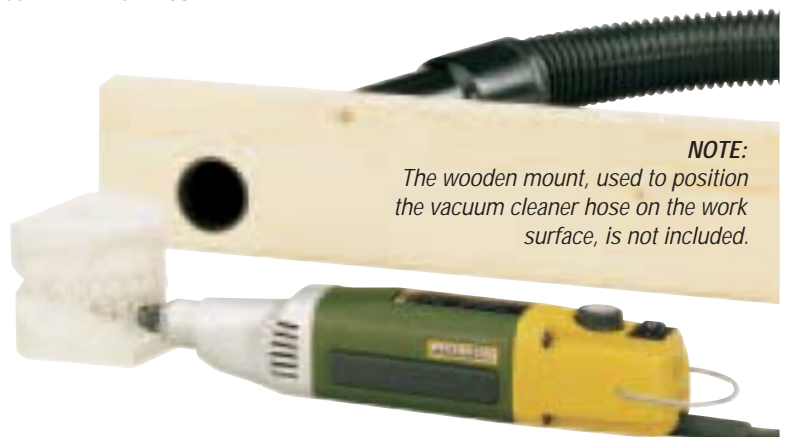

**NOTE:**  
The wooden mount, used to position the vacuum cleaner hose on the work surface, is not included.

## Bench drill machine TBM 220

220-240  
VOLT



The optional MICRO compound table to suit is described on page 16.

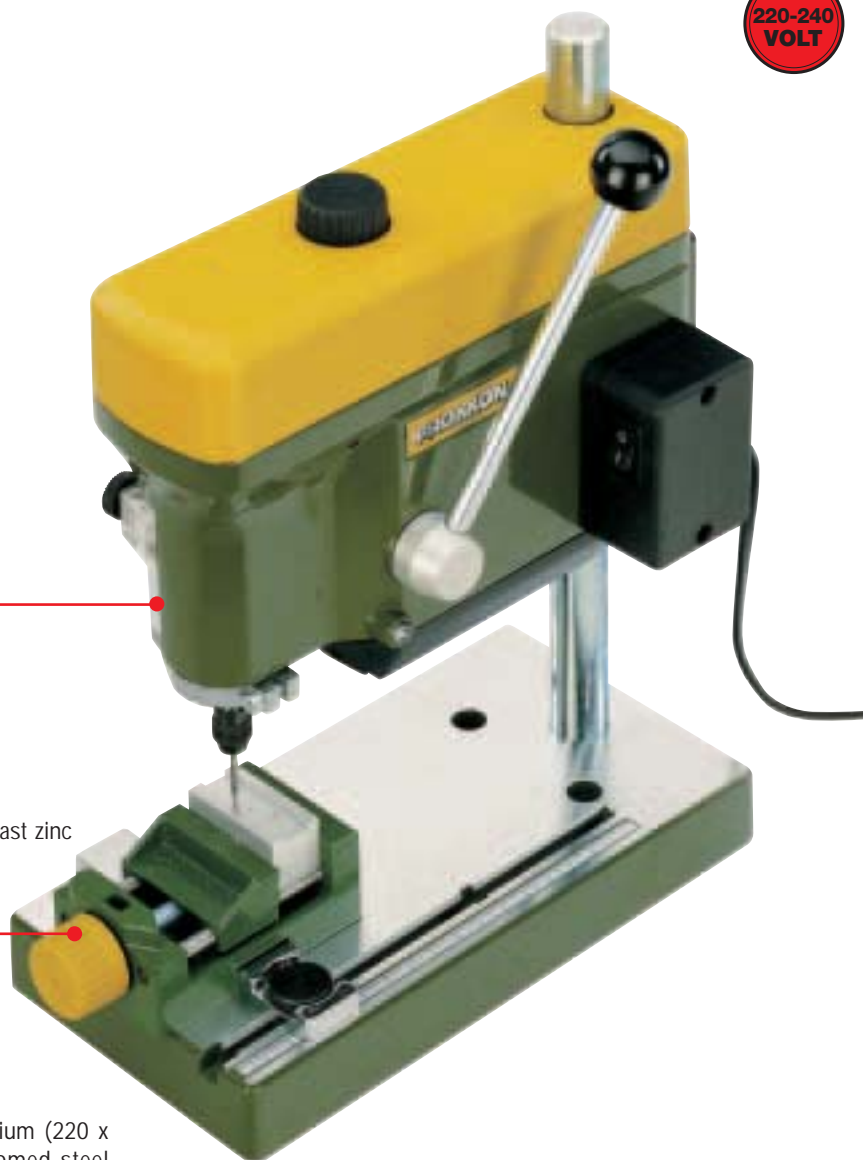

Practical, adjustable depth gauge.

Machine vice MS 4 made of die-cast zinc is an invaluable accessory and is described in detail on page 17.

Machined worktop of high quality, ribbed die-cast aluminium (220 x 120mm). Adjustable fence with scale. Solid, hard-chromed steel column, 280mm high, 20mm diameter. Super stable die-cast head with VDE approved 220 – 240V, 85W motor. Very quiet and of long life expectancy type. Power transmission by aluminium pulleys and flat belt. Three spindle speeds of 1,800, 4,700 and 8,500rpm. (Triple torque at low speeds). Chrome feed lever with adjustable depth scale. The spindle is essentially play-free as a result of the 3 high quality ball bearings. Recessed spindle for insertion of MICROMOT steel collets, but also threaded for drill chucks (3/8" thread).

Extremely high rotational accuracy, 30mm feed. Quill diameter 32mm, with return spring. Throat depth (column to drill spindle) 140mm. Quick coarse height adjustment of headstock with clamp levers. Max. height 140mm. Six triple slit precision collets for shaft sizes 1.0 – 1.5 – 2.0 – 2.4 – 3.0 – 3.2mm are included.

No 28 128

### Chuck

For drill shank sizes 0.5 to 6.0mm. Max. speed 10,000rpm. Industrial quality with extra high speed accuracy. With 3/8" thread for MICROMOT bench drill TBM 220, including chuck key.

No 28 122



### Dividing head for MICRO miller MF 70 and MICRO compound table KT 70

This accessory is used to drill offset holes, holes with equal spacing as well as milling key surfaces in 4 sided, 6 sided, etc materials. Graduated on the base. The chuck jaws may be reversed to yield 1.5 – 32mm (inside) and 12 – 65mm (outside) and bore of 11mm. This through hole allows long items to be clamped vertically in the chuck. Mounting holes to secure the unit vertically or horizontally are provided. T-nuts, complying with the MICROMOT norm, as well as mounting screws are included. Size 72 x 64 x 38mm. Supplied in wooden box with sliding lid.



No 24 264





*Small and beautiful: the accurate miller for lab technician, optician, jeweller, electronic/model builder.*

## MICRO miller MF 70

220-240 VOLT

Handwheels with zero adjustable scales,  
1 revolution = 1.0mm, 1 division = 0.05mm.

### Tungsten milling cutters

These double flute cutters are made from solid tungsten, clockwise cutting. The fishtail profile ensures cutting to the centre, allowing boring. Usable on cast iron, hardened cast iron, steel, cast steel, brass, aluminium, and even glass, plastics and carbon fibre. One each of 1.0-2.0 and 3.0mm. 3.0mm shaft diameter.



No 27 116 3 pieces

Now supplied complete with stepped clamp blocks of steel. These are shown on page 16.

Table of stable aluminium. Both axes are fitted with adjustable dovetail slides.

MICROMOT steel collets, triple slit and hardened, cover 1.0 to 3.2mm.

Continuously variable speed from 5,000-20,000rpm, perfect for even the smallest milling cutter.

Cutter clamping in MICROMOT system collets.

Stable cast iron base.

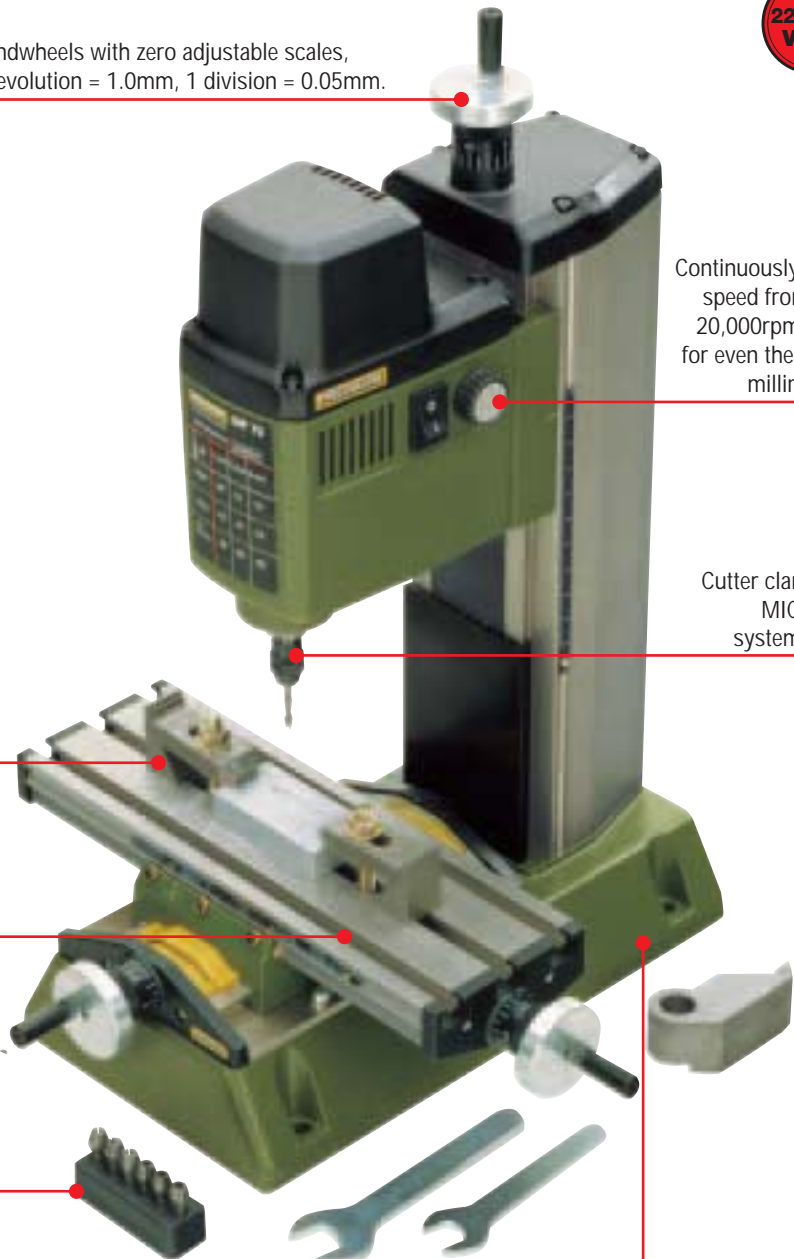

### For work with extremely small cutters.

Base of cast iron. Including both vertical column and compound table of treated, quality aluminium. All axes are play-free and have adjustable gibs. Headstock of die-cast aluminium contains the 24 pole balanced special motor and is super stable even at high operating speeds. This stability facilitates the use of the finest cutters. The triple slit, hardened steel MICROMOT collets cover 1.0 – 1.5 – 2.0 – 2.35 – 3.0 – 3.2mm. The table is fitted with 3 T-slots of the 12 x 6 x 6mm MICROMOT norm. An adjustable ruler scale eases the positioning of the workpiece. All handwheels are zero adjustable with 1 revolution = 1.0mm, 1 division = 0.05mm.

#### Technical Data:

220 – 240V, 100W, 50/60Hz. Spindle speeds 5,000 – 20,000rpm. Table 200 x 70mm with X-Y travel of 134 and 46mm respectively, with vertical travel 80mm. Footprint size 130 x 225mm and overall height 340mm. Weight approx. 7kg. The clamping blocks depicted are included too, but not the workpiece.

No 27 110

### Precision steel vice PM 40 Milled of steel.

Completely angular. Jaw width 46mm, clamping capacity 30mm. Total length 70mm. Especially suited for filigree and accurate working with MICRO miller MF 70 or Compound table KT 70. Sliding blocks and fixing screws included. Comes in a wooden box.



No 24 260

**MICRO shaper MT 300**

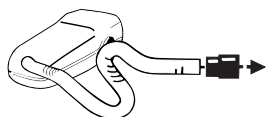

**NOTE:**  
The MT 300 is fitted with a dust collection channel and vacuum adapter. Using a vacuum extractor ensures a cleaner environment.



Used to profile, slot, route, chamfer, trim and cut. Also used for precision details on sides and long sections, e.g. doors, flaps and housing components.

Powerful, dust protected motor with toothed belt drive. Double ball bearing spindle. Cutters fitted in triple slit collets (1 each 2.4 - 3.0 and 3.2mm are supplied).

Cutter height adjusted by means of handwheel, zero adjustable with 1 rev = 1.0mm and 1 division = 0.05mm. Stable aluminium table with mitre gauge and parallel fence, as well as cutter guard and hold-down. Housing of ABS. Adapter for vacuum cleaner, fits standard household appliances.

**Technical data:**  
220 - 240V, 50/60Hz, 30,000rpm no load, maximum input 100W. Table 300 x 150mm. Weight approx. 2.0kg.

No 27 050

**Wood Router Cutter Set, 10 pieces**

A set with one each of the described cutters, neatly arranged in a wooden box.



No 29 020

**Note:**  
These router cutters should only be used in machines or accessories such as the router MT 300, router base OFV or the router table FT 300. Free-hand use of these cutters is extremely dangerous!

**Wood Router Cutters**

Made of molybdenum-chrome vanadium steel. Used in the manufacture of picture frames, for slotting, cutting radii and various profiles. Inverse relief ground for cleaner cuts. All shafts 3.2mm.

**Slot cutter**  $\varnothing$  3.2mm  
No 29 024

**Slot cutter**  $\varnothing$  5.0mm  
No 29 026

**Slot cutter**  $\varnothing$  6.5mm  
No 29 028

**Rounding over cutter**  
 $\varnothing$  6.4mm  
No 29 030

**V-slot cutter**  $\varnothing$  6.5mm  
No 29 032

**Combi cutter**  
6.5/2.5mm  
No 29 034

**Core box bit** R 3.2mm  
No 29 036

**Rebating cutter** 6.4mm  
No 29 038

**Edge cutter with pin**  $\varnothing$  5.0mm  
No 29 040

**Half round cutter**  $\varnothing$  13mm  
No 29 042

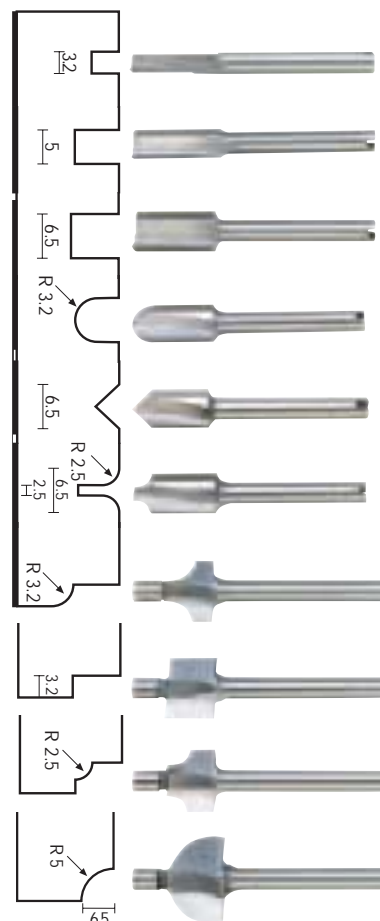



*The smallest and cutest in the world:  
40 x 80mm capacity!*

## Thicknesser DH 40



Load bearing components are all made of die-cast aluminium, with milled seats for bearings and spindles. These characteristics are essential for vibration-free, smooth thicknessing of hard and soft woods.

The triple spindled table is made from die-cast aluminium and milled to close tolerances. The hand wheel, zero adjustable, allows adjustments to 0.1 mm.

Auto feed is fitted as standard, as well as an anti-kickback device. The infeed roller is rifled and spring loaded to assist in feeding uneven materials. The outfeed roller is rubber coated to prevent marking the

newly planed wood.

The cutter block is fitted with two HSS knives. The on/off switch is dust protected and fitted with a no-volt release.

### Technical data:

220 – 240V, 200W, 50/60Hz. Thicknessing to 80mm wide and 40mm thick. Maximum depth of cut 0.8mm. Cutter speed 6,000rpm and feed rate 4.8 m/min. Table length 232mm. Overall machine dimensions 280 x 230 x 235mm. Weight approx. 8kg.

No 27 040

### NOTE:

*Minute splinters can influence the usefulness of planed wood. Precision is even more important when working in miniature.*



### Spare blades

The HSS blades are reversible. 82mm long.

No 27 042 1 pair



**Quiet yet powerful! Speed control from 200 - 1,400 strokes per minute. Smooth cuts without the need to finish.**

**Scroll Saw  
DSH/E**



Practical quick release lever for quick blade changes (important when cutting internally).

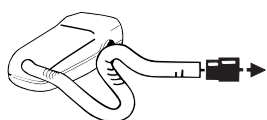

The DSH/E is fitted with a vacuum system adapter, used to keep the working area dust free.



The ideal machine for tool and die making, model building, toy repairs, puzzle sawing, architectural work, antique restoration, etc. Absolutely safe: ideal for schools and training centres.

Super cutting capacity (wood 50mm, plastics 30mm, non-ferrous metals 10mm) and yet runs with only a hum. Perspex, PC cards, foam, leather and cork are easily cut.



fig.1

Free moving blade chucks accept both pin and plain end blades. The slender over arm facilitates a clear view of the workpiece. The photo (fig. 1) shows the superb quick change lever, used especially with internal cuts.

Air blower with adjustable nozzle provides clear visibility of workpiece and cutting line. Machine base of cast iron with rubber feet for vibration-free operation and stability, may also be screwed down. Sturdy aluminium die-cast table 360 x 270mm tilts up to 45° for mitre sawing (fig. 2). Standard commercially available pin blades can be rapidly fitted and stored in the special compartment on the side of the machine. The clamping jaws also clamp plain end blades. Channel for the connection of a vacuum cleaner. Complete with 5 each coarse and fine blades and T allen key.



fig.2

**Technical data:** 220 – 240V, 50/60Hz. The special motor draws 200W and the electronic speed control yields constant speeds under load from 200 to 1,400/min. Stroke 19mm. 400mm throat with 50mm maximum depth of cut or 25mm at 45° table tilt. Length 53cm, height 30cm, width 27cm. Weight approx. 20kg.

No 27 090

**Standard Scroll Saw Blades with pin ends. 127mm.**



**Coarse pin end blades (10 TPI):** Ideal for cutting soft and hard wood, plastics as well as the soft and above all also thicker material.

No 28 740 127 x 2.61 x 0.51mm 6 blades

**Fine pin end blades (18 TPI):** Ideal for cutting soft and hard wood as well as other thinner materials and plastics.

No 28 742 127 x 1.86 x 0.24mm 6 blades

**Very fine pin end blades (25 TPI):** Ideal for cutting non-ferrous metals, plastics, fibreglass, acrylics and wood.

No 28 744 127 x 1.76 x 0.25mm 6 blades

**"Super-Cut" Scroll Saw Blades without pins. 130 mm.**

Ideal for cutting soft and hard woods, fibreglass, Perspex and soft non-ferrous metals .

**Coarse-toothed blades (14 TPI):**  
No 28 110 130 x 1.50 x 0.48mm 6 blades

**Normal-toothed blades, (17 TPI):**  
No 28 108 130 x 1.20 x 0.38 mm 6 blades

**Fine-toothed blades (25 TPI):**  
No 28 107 130 x 0.77 x 0.30mm 6 blades

**For hard metals like iron or PERTINAX.**  
**Fine toothed blades (28 TPI):**  
No 28 104 130 x 1.10 x 0.50mm 6 blades

**Extremely fine-toothed blades (41 TPI):**  
No 28 106 130 x 0.74 x 0.36mm 6 blades

**Spiral blade. 125mm long with plain ends (without pins).**



These blades cut all directions and obviate the turning of the workpiece (advantageous, especially with bigger workpieces). A 1.5 mm hole is required. Ideal for plastic, hard and soft woods.

No 28 746 125 x 1.2mm 6 pieces



Accurate, straight cuts are easy. Standard with height adjustment and tilting blade.

## Table saw FKS/E



**NOTE:**  
The smaller scroll saw, DS 230/E, is described on page 28.

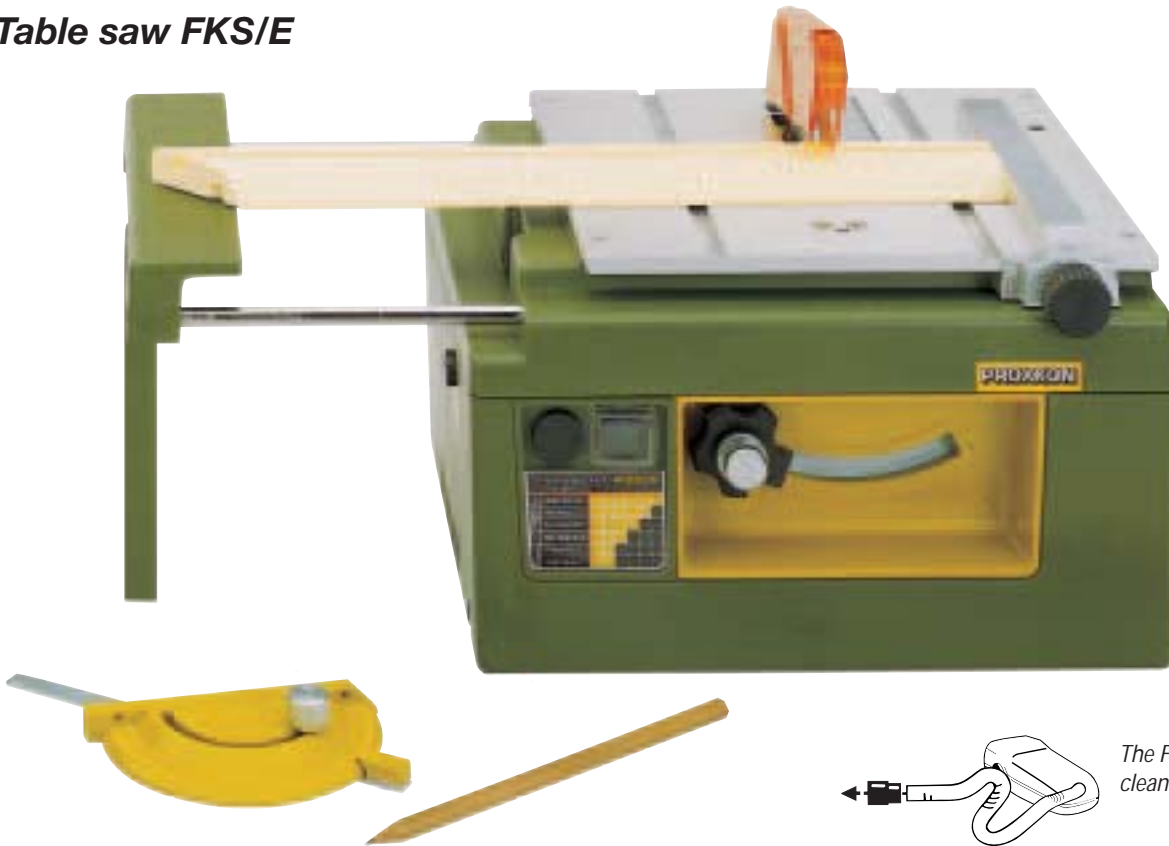

The FKS/E is fitted with a vacuum cleaner or dust extractor adapter, for use in a dust-free environment.

The ideal machine for straight, mitre and compound cuts. Usable on all wood types, non-ferrous metals, plastics (ABS, Pertinax, foam rubber) as well as rubber, cork, etc. Even the smallest items may be cut cleanly, obviating subsequent finishing: a table indicates the recommended speeds for various materials.

Substantial construction with load bearing parts of die-cast aluminium. Machined aluminium top measures 295 x 240mm. A mitre slot and fence are provided. An extension wing is housed integrally and pulled out to increase effective table width to 500mm.

Drive is effected via a special, quiet motor and optibelt toothed belt. The blade arbor is ball bearinged and fitted with a TCT blade (80 x 1.5mm, 24 tooth. No 28 734) as standard. Depth of cut is adjustable from 1 – 22mm and the blade may be tilted through 45°.

### Technical data:

220 – 240V motor, 50/60Hz. Electronic speed control, with feedback effect, for speeds of 4,400 – 6,800rpm. Overall size: 300 x 262 x 170mm (without extension wing). Weight approx. 5.2kg. Table size: 295 x 240mm. Depth of cut: 1 – 22mm, uses all blades 50 – 85mm diameter with 10mm bore.

No 28 070



### Dado head set

The dado set consists of a guard and tungsten blade of 50mm diameter, 2mm width. Used to cut slots (dados) in drawers, picture frames, etc. Slot depth max. 8mm.

No 28 736

**SUPER CUT**  
80 teeth, 85mm Ø x 0.5 x 10mm bore  
Used on hard and soft woods, plastics

No 28 731

**Tungsten carbide tipped**  
80mm Ø x 1.5 x 10mm bore, 36 teeth. Used to cut balsa, plywood, hard and soft woods, polycarbonate, plastic, alu and PC cards.

No 28 732

**Tungsten carbide tipped (TCT)**  
24 teeth, 80mm Ø x 1.5 x 10mm bore  
Used on aluminum, hard wood, laminates, plastics.

No 28 734

**Diamond coated**  
85mm Ø x 0.7 x 10mm bore. Used on glass, stone and tiles

No 28 735

**MICRO-Bandsaw MBS 240/E**



Solid, ribbed die-cast aluminium housing (not a tubular or sheet metal construction). Double ball bearing aluminium pulleys. Sturdy, machined table with slot for mitre gauge as well as coolant trough. Table tilts through 45° for accurate mitre sawing. Low noise 220V motor (high quality, for quiet, prolonged use) with toothed belt. Electronically controlled speed for exceptionally accurate cutting (No subsequent finishing necessary).

A table indicates the recommended speed for practically all materials. The blade size (5 x 0.4mm), is ideal for fine work, allowing cutting of small radii.

**Technical data:**

220 – 240V. Blade speed adjustment from 180 to 330/min. Throat 150mm, max height 85mm. Table 200 x 200, tiltable to 45°. One blade 1,065 x 0.4mm, 14TPI is included. No 27 172

PROXXON MBS 240/E													
Diamantiertes Sägeband							Stahlsägeband						
Stahl	Aluminium	Alu	PP	PE	PMMA	Acryl	Werkstoff	Werkstoff	Werkstoff	Werkstoff	Werkstoff	Werkstoff	Werkstoff
1	1	1	1	1	1	1	1	1	1	1	1	1	1
2	2	2	2	2	2	2	2	2	2	2	2	2	2
3	3	3	3	3	3	3	3	3	3	3	3	3	3
4	4	4	4	4	4	4	4	4	4	4	4	4	4
5	5	5	5	5	5	5	5	5	5	5	5	5	5
6	6	6	6	6	6	6	6	6	6	6	6	6	6

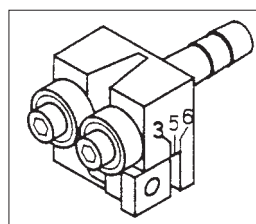

**Blade guides**

(see sketch above)

Triple ball bearing system with feed pipe for coolant when used with the diamond blade. Can also be used in conjunction with normal blades.

No 28 187

**Blades for MBS 240/E**

Swedish steel 1,065 x 5 x 0.4mm. Fine toothed (24TPI). For steel and brass.

No 28 174

As above, but coarse toothed (14TPI). For wood and plastics.

No 28 176

As above, but special tempered steel, with induction-hardened teeth. Extra narrow for tight curves (1,065 x 3.5 x 0.5mm). Coarse toothed (14TPI). For aluminium and plastic.

No 28 180

**Diamond blade for MBS 240/E**

For cutting ceramics, glass and fibreglass. 1,065 x 3 x 0.3mm. Must be used in conjunction with coolant system!

No 28 186



**NOTE:**

The cutting of glass and ceramics should only be attempted in conjunction with the coolant system (see page 39).

**Disc Sander TG 250/E**

**220-240  
VOLT**

Coolant system for wet grinding of glass, stone, tiles and steel.

250mm disc, surface machined and with double ball bearing spindle.

Table size: 275 x 105mm, with slot for mitre gauge. Tilts up to 45°.

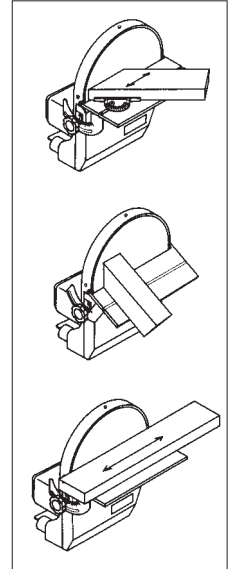

*The band saw and disc sander are equipped with vacuum cleaner adaptors: work in a clean, dust free environment!*

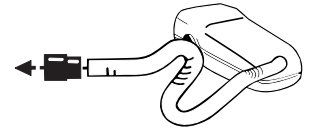

Sands long edges, end sections, radii, mitres, and, by turning work piece over - accurate flat surfaces at right angles. Used on soft and hard woods, non-ferrous metals, steel, plastics (plexiglass and fibreglass), cork and rubber. A simple chart indicates the recommended speeds on different materials.

**Sturdy construction:**

Main body of ribbed die-cast aluminium (not a steel tube or sheet metal construction). Machined backing disc - driven by a twin ball bearing spindle. Standard commercially available sanding discs fix firmly and can be replaced quickly. A dust collection adaptor for attaching a vacuum cleaner or dust extractor is included.

**Technical data:**

220 – 240V with drive via toothed belt (reduction ratio 7.3:1) Electronic speed control approx. 250 – 750/min. Disc diameter 250mm. Max. sanding height 135mm, table 275 x 105mm (tilts 15° in, 45° out). Overall size without table 330 x 280 x 230mm. Complete with mitre gauge and 2 each sanding discs of 80 grit and 240 grit.

No 28 060

**Self adhesive sanding discs for TG 250/E, 250mm Ø.**

Industrial quality. Carborundum with resinoid bond. For sanding soft and hard woods, laminates, non-ferrous metals, steel, plastics, cork, rubber and minerals.

No 28 970	80 grit	5 discs
No 28 972	150 grit	5 discs
No 28 974	240 grit	5 discs

**Self adhesive waterproof replacement discs for TG 250/E, 250 mm Ø.**

Silicon carbide with resinoid bond, usable on NF metals, steel, glass, PC cards, plastic and ceramic. May also be used with the coolant option.

No 28 976	320 grit	5 discs
-----------	----------	---------

**Wet sanding of glass, stone and tiles with the MBS 240/E and TG 250/E.**

**Coolant container**

Made of plastic. With stop cock and regulator. 100cm tubing as well as 2 nipples for the MBS 240/E table and mounting bracket (incl. screws). Holds 1 litre.

No 28 188

**Coolant collection tray**

Size 420 x 310 x 15mm. Includes gasket for sealing the fixing holes of the machine. With 50cm discharge tube and nipple for band saw table. The tray is undrilled and may be used on other machines too.

No 28 189

## Cut off/mitre saw KGS 80

220-240  
VOLT

**NOTE:**  
Optional blades are described on page 37.

Laterally moving saw head to minimize distance between vice holding the work piece and kerf. For cutting without vibration and chattering!

Fence adjustable to 300mm.

Comfortable grip with built-in switch and saw head release button.

The blade guard, made of POLYCARBONATE, is raised automatically.

Tungsten carbide blade for NF metals, wood and plastic. Direct drive via a toothed belt.

Round table made of die-cast alu, rotates 45° left and right. Positive stops in 15° increments.

Integrated clamping system with fixed jaws. V-slot for round workpieces. Front side slot allows thin pieces to be clamped.

**This machine is ideal for mitre cuts: the round worktable with clamped work piece rotate, not the headstock!**

The laterally moving headstock (patent DP 103.18.479.1) eliminates any possibility of the blade and clamping system colliding. The minute spacing between the kerf and clamping system ensures cutting with a minimum of chatter and vibration.

The fence and 45° mitre capability ensure identical lengths for picture frames. Powerful, quiet DC motor. Power transmission takes place via a toothed belt. The tungsten tipped blade (80 x 1.6 x 10mm, 24 teeth cuts NF metals, wood and plastic.

### Technical Data:

220 – 240V. 200W. 50/60 Hz. 4,000/min. Base with round table of highly stable, die-cast alu, with CNC milled fittings and slides. Table size 230 x 230mm. Weight 6kg. Consult the table for cutting capacities.

No 27 160

Cutting capacity at 90° (right angle cut):			Cutting capacity at 45° (mitre cut):		
Material size (in mm)	Max. material width (in mm)	Round material (in mm)	Material size (in mm)	Max. material width (in mm)	Round material (in mm)
10	65		5	36	
18	50		10	30	
21	40		15	25	
25	25	Ø max. 25	20	18	Ø max. 20

### Cutting disc with reinforcement, 80 x 1.0 x 10mm



Corundum compound, used on steel, NF metal, plastic and wood.

No 28 729

### Tungsten tipped blade, 80 x 1.6 x 10mm, 36 teeth



The high tooth count yields clean cuts when cutting a variety of materials, e.g. balsa, plywood, soft wood and PC cards. May also be used on hard wood, POLYCARBONATE, plastic and alu. Fits the table saw FKS/E as well.

No 28 732





*Quiet and accurate. Ideal for the lab, workshop and delicate operations.*

### **Drill press TBH**

*Made of highly stable die-cast parts with CNC milled fittings and slides.*



The height adjustment is easily altered by means of the headstock crank and lock lever. The table features a ribbed base, milled work area with T-slots. The column is bright nickel-plated. Powerful, long life 220 - 240V permanent magnet motor. The quill is driven via a Poly-V belt and three step pulleys. This yields a torque multiplication of as much as 6x at the lowest speed. Gearing quill feed for exact operations runs in ball bearings. Practical depth gauge with adjustable depth stop.



Spindle with 1/2" thread accepts the standard chuck, as well as the optional collets.



Compound table KT 150 is described on page 50.

#### **Technical Data:**

220 - 240V motor with spindle speeds 1,080, 2,400 and 4,500rpm. Quill travel 63mm, headstock travel via the crank 70mm. Throat of 140mm. Maximum drill bit size 10mm, which is also the capability in steel. The optional collets offer a capability to 6mm. Useable table size 200 x 200mm. Column 45 x 500mm.

No 28 124

### **Collet set for drill press TBH**

Triple slit and hardened. One each of 2.35 - 3.0 - 3.2 - 4.0 - 5.0 and 6.0mm. Also includes the collet closure nut (M17). Packed in wooden box with sliding lid.

No 28 200

### **T nut set for vices**

Two T nuts and cap screws with washers. Used on BFB 2000, KT 150 and TBH.

No 20 394



*The simple and easy adjustment is perfect for accurate work.*

### **Precision vices. Exhibit feed, ease of operation and accuracy:**

#### **PRIMUS 75**

Fitted with interchangeable, hardened jaws, slotted vertically and horizontally so round and odd shaped objects may be clamped. Both jaws are slotted at the top, facilitating gripping of flat work pieces. The solid, cast iron base has CNC machined ways. Its relatively high mass may allow use of the vice without fastening it down. The feed screw features a rolled thread which ensures ease of movement even with high axial loads. Jaw width of 75mm, opening to 65mm. Distance between centres of fixing slots is 100mm. Slot size 80 x 11mm. Weight 2.5kg.

No 20 392



#### **PRIMUS 100**

Jaw width of 100mm, opening to 75mm. Distance between centres of fixing slots is 135mm. Slot size 105 x 15mm. Weight 5.0kg. Other details as for the PRIMUS 75.

No 20 402

*Complete with chuck, live centre and top slide  
(for taper turning).*

**Quality you can see and touch.**

The PD 230/E is designed for those who appreciate quality. However, to use the lathe does not mean you need to be a professional turner. The handbook is detailed and easy to understand.

The lathe runs quietly and is small and light enough to be packed away after each usage. This notwithstanding, centre height and distance between centres are sufficient for a multitude of tasks.

**Lathe PD 230/E**

*Usable on materials such as plastic, steel, brass and aluminium. Complete with automatic feed, thread cutting capability, headstock chuck, live centre and top slide for taper turning. Used to part, machine stock and cut tapers. The numerous optional accessories allow one to drill, mill and slot.*

Gear casing with a table showing the appropriate speed for the material and diameter.

Combination of three speeds (attained by swapping drive belt position) and electronic speed control yield speeds of 100 to 3,000rpm.

Headstock spindle with 10.5mm bore and MT1 taper.

Main switch with emergency stop function and restart protection.

Three jaw chuck, 2 - 68mm capacity.

The top slide, used for taper turning, and the tool holder are included as standard!



Enclosed leadscrew for automatic feed of 0.05 or 0.1mm/revolution.

Cast iron bed with ground prism for tool rest and tailstock ensures minimal deflection, even at high loads.

**Technical data:**

Centre distance of 230mm, swing 52mm. Height over cross slide 28mm. Cross slide travel 60mm and top slide 45mm. Tool holder accepts 8 x 8mm cutters. The MT1 (short) spindle has a bore 10.5mm. It runs in precision ball bearings, yielding an accuracy of 0.01mm without chuck. The thread cutting capability covers the most important pitches of 0.5 – 0.625 – 0.7 – 0.75 – 0.8 – 1.0 – 1.25 and 1.5mm. Spindle speeds are changed by means of a belt and offers 300, 900 and 3,000rpm.

The electronic speed control further extends the speed range down to 100rpm, which is important when cutting threads. The automatic feed offers 0.05 and 0.1mm per revolution. The tailstock spindle has a MT1 (short) bore and 30mm travel. The 220 – 240V motor is fitted with a

forward/reverse switch. The three jaw chuck offers 2 – 35mm capacity (internal jaws) and 24 – 68mm (external jaws). The hand wheels are fitted with zero adjustable scales. One revolution equals 1mm feed (40 divisions) and hence 0.025mm/division. Weight approx. 10kg and dimensions approx. 530 x 250 x 150mm.

No 24 004

## Accessories for the lathe PD 230/E (also compatible with its predecessor PD 210).

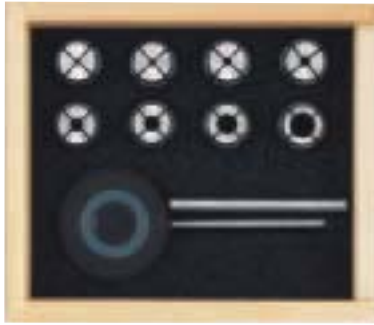

### Collet set for accurate use on round components

One each 2.0 – 2.5 – 3.0 – 4.0 – 5.0 – 6.0 – 8.0 and 10mm are included. Concentric accuracy better than 0.2mm, much better than a chuck. The collets are mounted in the place of the headstock chuck. Supplied in a wooden box and lid.

No 24 042

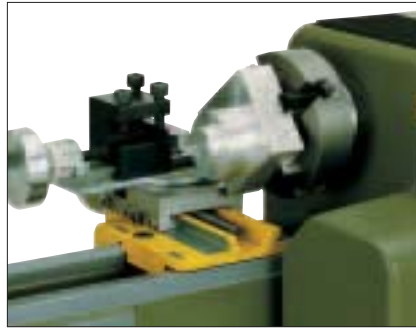

### Four jaw chuck

The 4 jaws are adjusted independently, thus clamping unsymmetrical pieces, ovals, squares and odd-shaped work pieces. The jaws are reversible and hardened, giving a capacity of 80mm. The workpiece must be centred manually.  
No 24 030

### Three jaw chuck, self centering

Self centering with reversible jaws. Capacity 2 – 68mm. Chuck body made of steel. Suitable for PD 230/E and dividing attachment No 24 131 (as depicted on the PD 230/E).  
No 24 028



### Fixed steady

Used when turning long, slender pieces, capacity up to 40mm. Also used when the tailstock cannot be utilised.  
No 24 080

### NOTE:

For radius cutting attachment, also to be used for the lathe PD 230/E, see page 48.

MT 1 live centre included as standard.

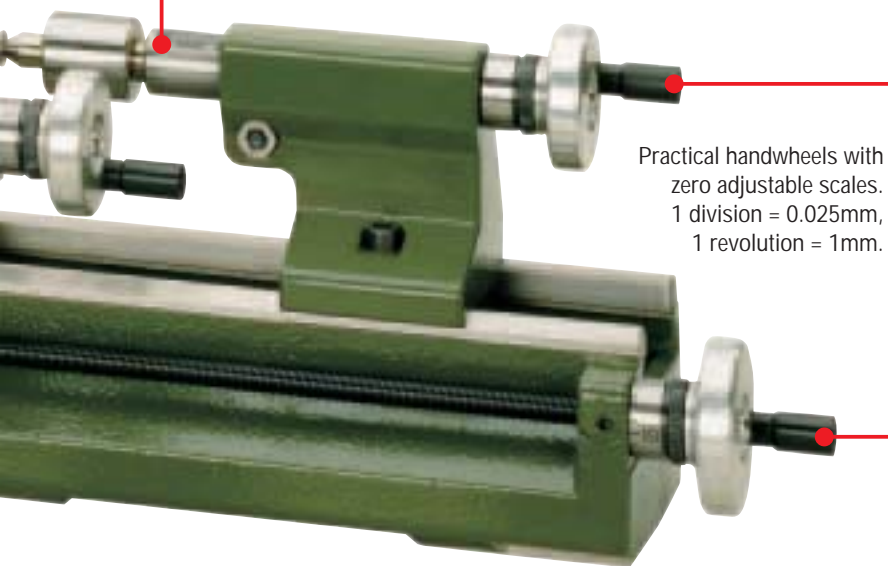

Practical handwheels with zero adjustable scales.  
1 division = 0.025mm,  
1 revolution = 1mm.



### The mill/drill head PF 230 converts the PD 230/E to a machining centre.

Set includes column (35 x 400mm), mounting bracket and bolts. The mounting position on the PD 230/E is already milled. The lathe's top slide is replaced with the table (supplied) of 110 x 70mm, with 3 T-slots 12 x 6 x 6mm. The lathe now functions as a compound table, with X-Y travel being longitudinally and cross-wise respectively. The mill/drill head is identical to the FF 230 (see page 44). Three collets of sizes 6, 8 and 10mm are included.  
No 24 104



### Centre turning attachment

Used for highest accuracy with high rotational precision. One face plate, 2 fixed MT 1 (short) centres, and 1 drive dog are included. Supplied in a wooden box and lid.

No 24 070

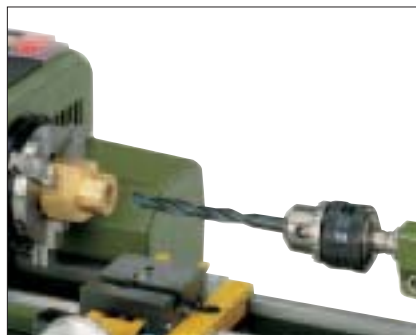

### Gear chuck

Capacity to 10mm, with key and MT1, for tailstock.  
No 24 020

As above, but with 10mm arbor, for mill/drill unit  
No 24 110

**IMPORTANT:**

*Milling is best carried out with the headstock locked in position. The FF 230's lock levers achieve this effortlessly.*

**Dividing attachment PD 230/E**

Facilitates the machining of gear teeth and non-concentric patterns. Supplied with two dividing discs (40 and 48 steps), enabling standard divisions of 2, 3, 4, 5, 6, 8, 10, 12, 16, 20, 24, 40 and 48. The spindle of the attachment is identical to that of the lathe. The 3 and 4 jaw chuck may therefore be fitted to it as well (the chuck is an optional accessory). May be fitted to the lathe's cross slide or to the bed and can also be fitted to the FF 230. Supplied in a wooden box and lid.



No 24 131

Handwheel serves as both height adjustment and mill fine feed.

Poly-V drive system offers 6 speeds between 280 and 2,500rpm.

The fine step feed, clamps and cutter are not included. (Description on page 16)



**MICRO miller FF 230**

The MICRO miller FF 230 is a small, accurate milling system used to mill, drill and countersink steel, cast iron aluminium, brass and plastic.

The headstock swivels through 360°, indicated on a scale. Height is adjusted via a zero adjustable handwheel, also used as fine feed when milling. One revolution equals 1mm travel, 1 division equals 0.05mm. The quill and headstock may be locked in position, essential when milling. The powerful permanent magnet motor effects drive via a poly-v belt, yielding high torques, especially at lower speeds. Collets of 6, 8 and 10mm are included. The solid table is T-slotted to the MICROMOT norm of 12 x 6 x 5mm.

**Technical Data:**

The 140W motor accepts 220 – 240V, 50/60Hz. Spindle speeds of 280, 550, 870, 1,200, 1,500 and 2,200rpm are achieved by pulleys and a belt. Table size 270 x 80mm, column 35mm x 400mm long. X-Y travel is 170mm x 65mm. Maximum height 180mm and depth 130mm. Overall height approx. 500mm. Weight approx. 17kg.

No 24 108

**Fine Feed for Milling machine PF 230 and MICRO miller FF 230**

Easily installed. The feed may be used via either the height feed (vertical) or the fine feed in the tilted position. One revolution is equivalent to 1.5mm spindle travel, with 1 division = 0.05mm. The graduated scale may be zero reset.

No 24 140

**Compound table KT 230**

As described above, but excluding headstock and column. Fits the PF 230 and PF 210. Weight approx. 11kg.

No 24 106

**Five piece collet set for PF 230 and FF 230.**

Includes 1 each of 2.4 – 3.0 – 3.2 – 4.0 and 5.0mm, for round stock. Supplied in a wooden box and lid.

No 24 144

Handwheels with zero adjustable scale, 1 rev = 1mm, 1 division = 0.05mm.

**Nearly all the components are supplied in sturdy wooden boxes.**



**Milling cutter set (2 - 5mm)**

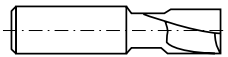

HSS, all with 6 mm shank. Consists of cutters of 2, 3, 4 and 5mm dia. Double fluted, to DIN 327. Supplied in wooden box and lid.  
No 24 610

**Milling cutter set (6 - 10mm)**

HSS, consisting of cutters 6,7,8 and 10mm dia. Four flute to DIN 844. Supplied in wooden box and lid.

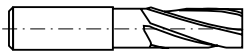

No 24 620

**Three piece centre drill set**

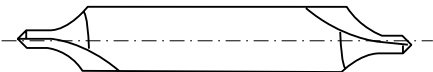

HSS, Din 333 (type A) 60°. Complete set with sizes of 2.0 - 2.5 and 3.15mm  
No 24 630

**Arbor (A)**

Used with gear cutters with 16mm bore, 10mm shaft.

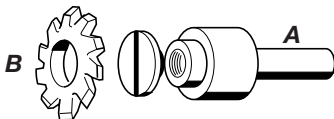

No 24 425

**HSS gear cutters (B)**

Module 0.5 x 40mm, 16mm bore.

- No 24 426 No. 1 12-13 teeth
- No 24 427 No. 2 14-16 teeth
- No 24 428 No. 3 17-20 teeth
- No 24 429 No. 4 21-25 teeth
- No 24 430 No. 5 26-34 teeth
- No 24 431 No. 6 35-54 teeth

**Step clamp set**

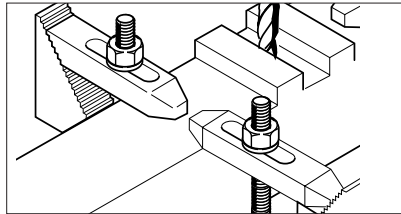

Consists of 2 step blocks and 2 clamps, 2 nuts, 2 T-slot nuts: B = 7, E = 12, D = 4 and C=7.2mm) secures objects to approx. 35 mm high. May be used with PD 230/E, FF 230/250, PD 400, KT 150 and face plate 24 412 and KT 150. Supplied in wooden box and lid.  
No 24 257

**Cutting tools of high quality cobalt HSS steel, ground. Five piece set**

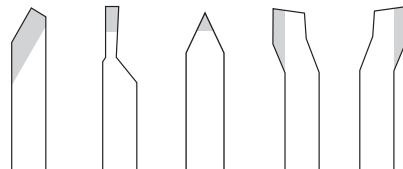

One each roughing out, parting, finishing cut, left and right cutter. Supplied in wooden box and lid.  
8 x 8 x 80mm (for PD 230/E)  
No 24 530  
10 x 10 x 80mm (for PD 400)  
No 24 550

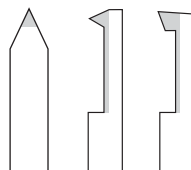

**Three piece thread cutting set**

One cutter for external thread (ground to 60°, metric) one for internal thread, one general cutting. Supplied in box and lid.  
8 x 8 x 80mm (for PD 230/E).  
No 24 540  
10 x 10 x 80mm (for PD 400)  
No 24 552

**Parting tool holder and tool**

Used in the PD 400 quick-change system. Used to part stock and cut slots. The 12 x 3 x 85mm HSS tool contains cobalt.  
No 24 417

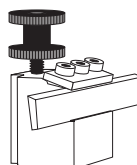

**Spare tool for parting tool holder**

As described above.  
No 24 554

**Cutter set with tungsten inserts for PD 230/E and PD 400**

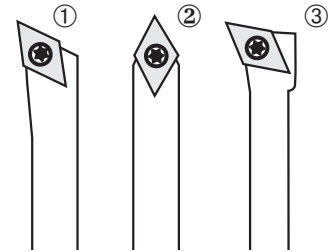

Three holders for roughing out (90mm), longitudinal work (90mm) and 90mm boring bar, holes from 12mm. Standard tungsten inserts, 55°, plated. Three additional inserts securing screw and key TX 8 are included.  
No 24 555 8 x 8mm (for PD 230/E)  
No 24 556 10 x 10mm (for PD 400)

**Tungsten disposable tips**

For the holders as described above. Ten piece set.  
No 24 557

**Precision V-Blocks**



Used to clamp various workpieces. Made from hardened steel, precision ground in pairs. Different depths of V, all at 90°. Size 50 x 30 x 30mm. The solid clamp and knurled knob ensure superb securing of the workpiece. Supplied in wooden box and lid.  
No 24 262 2 pieces

**Lathe techniques for model builders**



This book is available only in German.

No 24 999

*Accuracy, versatility and to DIN 8606. Complete with 3 jaw chuck, live centre and thread cutting capability.*

**220-240  
VOLT**



***The lathe PD 400. You will probably be wasting your time if you are trying to find similar value for your money!***

Ideal for straight and cross cuts, taper turning, internal and external thread cutting, slotting, etc. Useable on materials such as steel, non-ferrous metals, aluminium and alloys. Negligible tolerances even under heavy loads. Ground and hardened, wide bed-ways of ribbed construction for highest precision and stability (substantially better than bar and rod bed types). The wide range of accessories complements the lathe's functions. The bed is already equipped with a milled and tapped surface for securing mill/drill PF 400.

**Technical data**

Distance between centres 400 mm and swing over bed 170mm and over the top slide is 116mm. Solid, ribbed bed is made from quality cast iron with ground and hardened ways. Oversized spindle with 2 adjustable taper bearings, MT3 taper and 20.5mm bore. Run-out, without chuck, 5/1,000mm. Includes the precision 3 jaw chuck, 100mm diameter. Six spindle speeds are provided via belt drive: stage 1: 80, 330, 1,400rpm and stage 2: 160, 660, 2,800rpm.

Powerful, quiet motor with 550W power output. All adjusting wheels fitted with scales that may be zeroed. One division = 0.05mm. The auto feed has speeds of 0.07 or 0.14mm/rev. An integrated gearbox, for LH and RH threads, with change gears provides 19 metric pitches:

0.2 – 0.25 – 0.3 – 0.35 – 0.4 – 0.45 – 0.5 – 0.6 – 0.7 – 0.75 – 0.8 – 0.9 – 1.0 – 1.25 – 1.5 – 1.75 – 2.0 – 2.5 – 3.0mm. Imperial threads of 10 – 48 TPI are also possible.

A rotating centre MT 2 and tailstock chuck of 10mm capacity, B12 taper, are included. Leadscrew with acme thread 12 x 1.5. Cross slide travel 85mm, top slide 55mm and adjustable to turn tapers, with graduations up to 45°.





*Individual tools are on page 45, additional accessories for the PD 400 are depicted on page 48.*

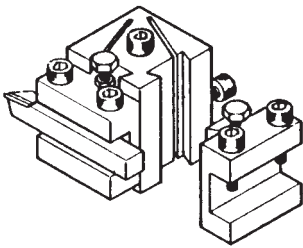

A tool holder with two adjustable inserts is included as standard.

**Tool post**

Including two holders. Provides quick tool changes with easy height adjustment.  
NO 24 415

**Individual quick-change holder**

No 24 416



**4 Jaw chuck with independent jaws**

Used to mount irregularly and asymmetrically shaped objects. Each jaw is adjusted individually and centering is thus achieved manually. Hardened, reversible jaws.

Chuck diameter 100mm.  
No 24 410

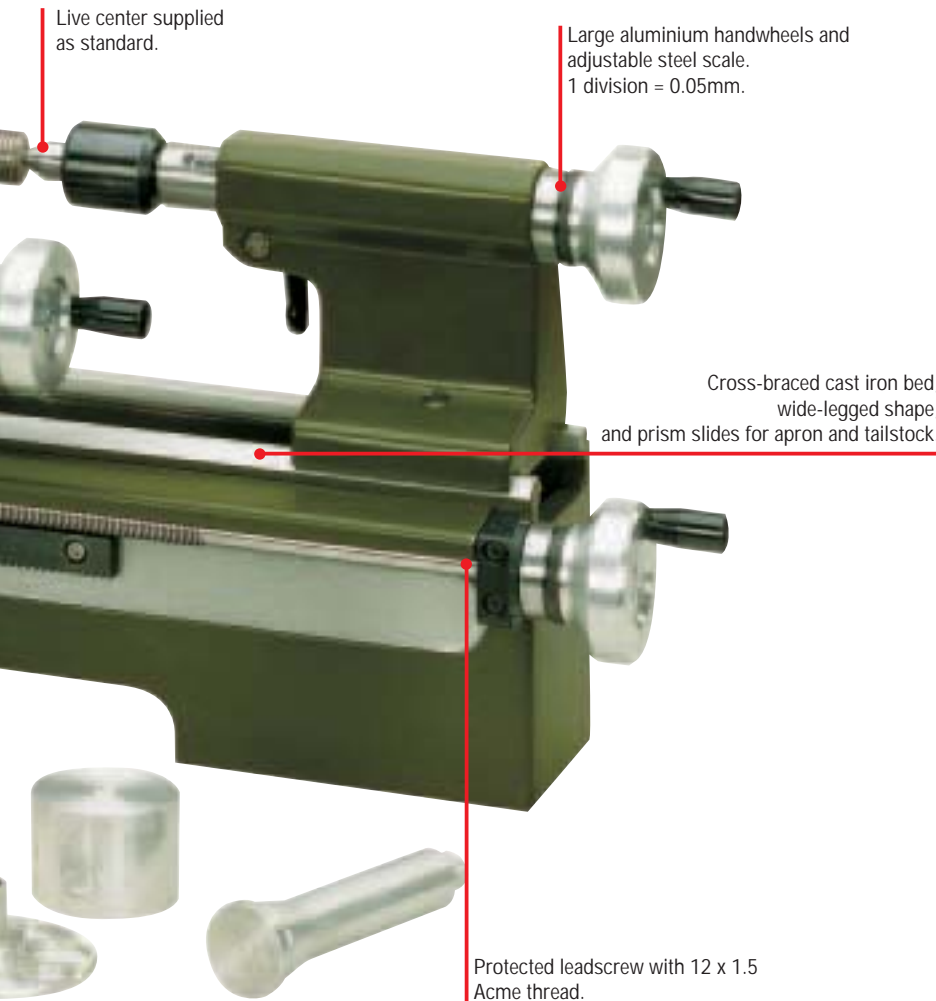

Live center supplied as standard.

Large aluminium handwheels and adjustable steel scale. 1 division = 0.05mm.

Cross-braced cast iron bed, wide-legged shape, and prism slides for apron and tailstock.

Protected leadscrew with 12 x 1.5 Acme thread.

Tailstock with MT 2, 24mm diameter and 40mm travel (with graduations).

Overall size approx. 900 x 400 x 300mm (L x W x H).

Weight approx. 45kg.

Uses cutting tools 10 x 10mm.



No 24 400



**4 Jaw chuck, self-centering**

The jaws are not independently adjustable, i.e. they are self centering.

High accuracy 100mm chuck.  
No 24 408



**Faceplate and clamps**

This accessory is used in the place of the standard chuck and mounts larger and asymmetrical workpieces. Diameter of 150mm, with 2 through T-slots, as well as mounting clamps.

No 24 412



**Radius cutting attachment**

Usable on both the PD 230 and PD 400 and is mounted on the cross slide in place of the tool holder. Cuts concave and convex shapes, to depth of 1.0mm in steel, as well as non-ferrous metals and plastics. Radii or 3/4 spheres of diameter up to 32mm are possible. Supplied in wooden box and lid.  
No 24 061



**Fixed steady**

Used on the PD 400 when turning long, slender work. Fitted directly to the bed ways and is used when the tailstock support is inadequate. Capacity to 50mm  $\varnothing$ .

No 24 404



**Collet set for accurate use on round components**

One each 2.0 – 3.0 – 4.0 – 5.0 – 6.0 – 8.0 – 10 and 12mm are included. Concentric accuracy better than 0,2mm, much better than a chuck. One soft collet for making a custom size yourself. The included collet attachment is mounted in the place of the headstock chuck.

No 24 419 complete



**Travelling steady**

Fitted to the carriage of the lathe. Indispensable when turning long, slender pieces. Maximum 50mm  $\varnothing$ .

No 24 406



**Centre turning accessory for the PD 400**

(Shown on the left)  
Ideal when turning with highest possible accuracy. Supplied with 2 dead centres (MT2 and MT3), drive/face plate with 30mm bore as well as reducing bushes 30/20mm and 30/15mm. A threaded drive pin screws into the headstock flange and the drive plate.

No 24 414



**Universal dividing table UT 400**

Facilitates the manufacture of odd-shaped objects. The table may be fixed horizontally or vertically. Drive takes place via the worm drive and in its 360° travel yields nearly all the divisions below 100. Supplied with 4 index plates: 27/42, 33/40, 34/39 and 36/38. Used to manufacture sprockets, gearboxes and drives, ratchets, cams, etc. The faceplate is not included. Supplied in wooden box and lid.

No 24 421

**Mill/Drill PF 400**

Kit also includes the mounting flange and screws (the mounting surface on the PD 400 is already machined). Identical to the MICRO miller FF 400, except that no compound table is supplied. Instead, a work surface of steel (150 x 110mm), with 3 milled T-slots for the standard T-nuts, is supplied. Two screws secure the work surface to the cross slide.

No 24 304

**Splash guard and chip collecting tray**

Made from 1.25mm steel plate, powder coated. A welded cover protects the motor. Mounting holes and raised base to secure the lathe are pre-drilled. Seeping through of coolant is impossible. Length 800 x 270 width x 290mm height.

No 24 402

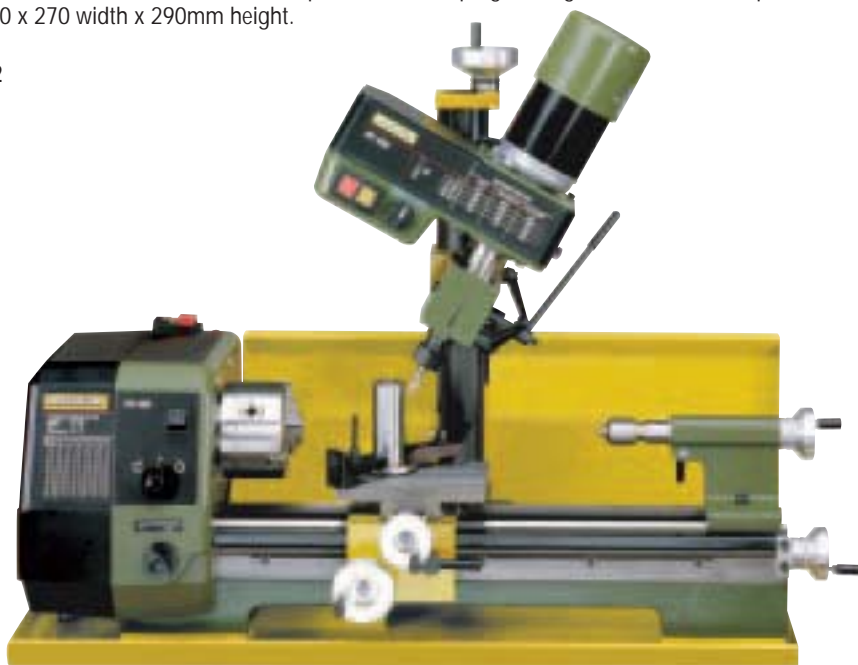



## MICRO Miller FF 400

### IMPORTANT:

*Both the headstock and spindle can be locked in position when milling.*

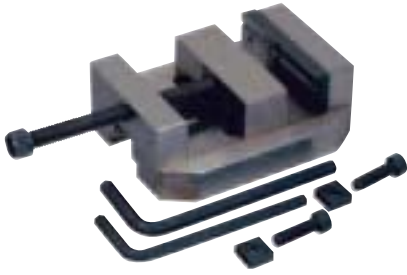

### Precision vice. Milled in steel.

May be used on its side and back. Jaw width of 60 mm, clamping capacity 42mm. Complete with securing bolts and packed in a wooden box.

No 24 255



### Gear tooth chuck (10mm) with adapter

Industrial quality, however not as accurate as the collets. With 10mm adapter which fits into the 10mm collet. Includes the chuck key.

No 24 110



### Fine feed for accurate adjustments

Quick and easy to install. The clutch system enables feed via either the drill handle or the handwheel. The handwheel has 0.025 graduations and may set to zero.

No 24 254

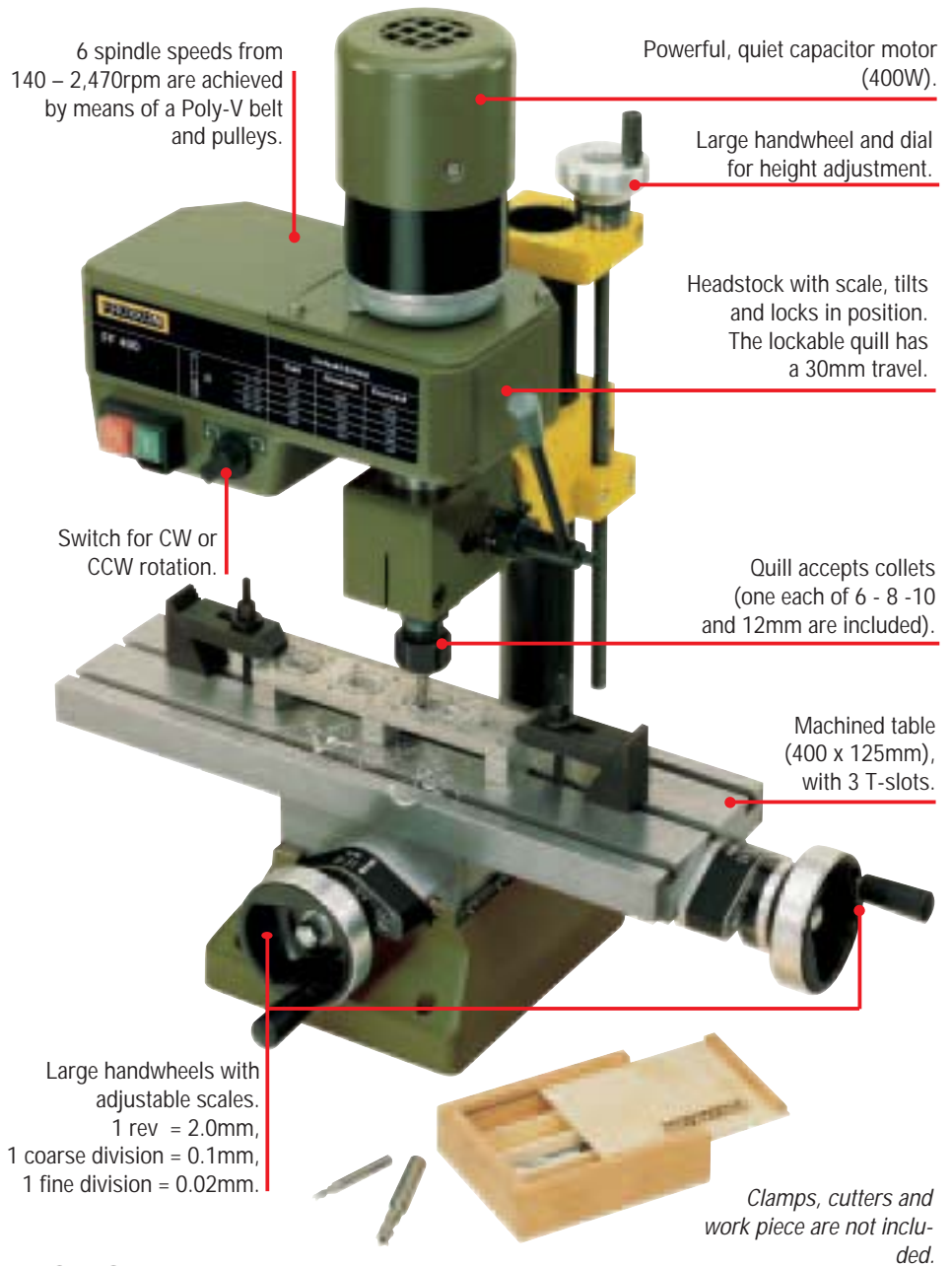

## MICRO miller FF 400

The headstock swivels through 360° indicated on a scale. The lockable quill has a travel of 30mm (via the handle and scale) and the throat distance is 100mm. Six spindle speeds of between 140 and 2,470rpm are achieved by means of pulleys and a belt. Cutting tools are secured in the 6, 8, 10 and 12mm collets provided. The headstock height is adjusted via the handwheel and dial (1 rev = 2.0mm) The solid, milled compound table has 3 T-slots for the standard T-nuts.

**Technical data:** 220 – 240V, 400W, 50/60Hz. Spindle speeds of 140, 310, 480, 730, 1,140 and 2,470rpm. Column 45 x 500mm and table 400 x 125mm. X and Y travel amount to 225 and 80mm respectively. Footprint size 370 x 350mm. Overall height approx. 600mm. Weight approx. 40kg.

No 24 308

### Five piece collet set for PF 400 and FF 400

Includes 1 each of diameter 2.4 – 3.0 – 3.2 – 4.0 und 5.0mm, for round stock. Supplied in wooden box and lid.

No 24 252

### Compound table KT 400

As described above but excluding the column and headstock. The 45mm bore also fits the precision drill stand BFB 2000. Weight approx. 23kg.

No 24 303

**Mill/drill system BFW 40/E, with controller for speeds of 900 - 6,000rpm.**

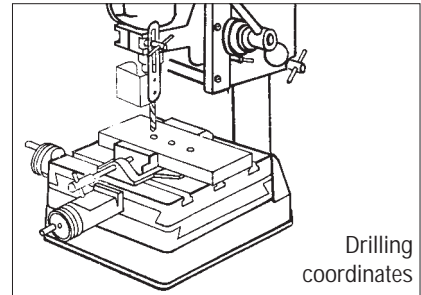
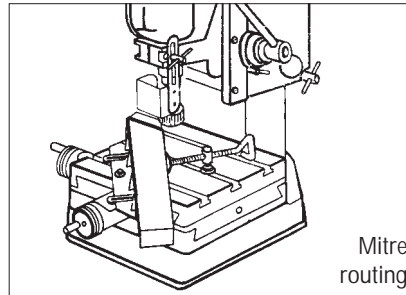
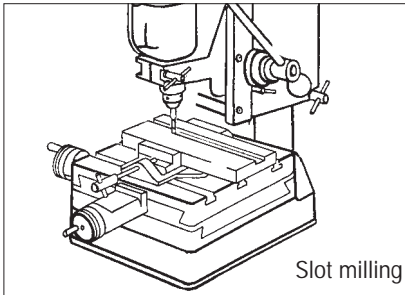

The triple ball bearing armature provides direct drive (no gearing). This yields virtually vibration-free operation and extremely high spindle accuracy. Aluminium die-cast head with spindle neck of 43mm (European standard). Remainder of casing fibreglass reinforced NYLON. Large, easy to use switch with emergency function. Chart indicates optimum speeds for milling and drilling various materials.

**Technical data:**

Control unit with full wave electronics for 220 – 240V, 40VDC secondary voltage. Power consumption up to max. 250 Watt. Spindle speed infinitely variable between 900 and 6,000rpm. Complete with triple slit, hardened collets covering 2.35 – 3.0 – 3.2 – 4.0 – 5.0 and 6.0mm, as well as 2 spanners.

No 20 165

**Aluminium die-cast compound table KT 150.**

With precision milled dovetail slides, thus also suitable for metal work. For routing, milling, slotting of steel, non-ferrous metal, plastic and wood. Each slide provided with locking screws. Dovetail fittings/gib strips adjustable to eliminate play. Feed adjustments by means of 2 hand wheels with adjustable, graduated dials (one revolution = 2 mm, one graduation = 0.05mm). Machined table, 3 T-slots for fastening machine vices and clamping kits. Fence supplied with pre-drilled positioning holes, including 45°, fastenings screws and clamp used for routing. Table 200 x 200mm. Max. travel 150 x 150mm. Overall height 75mm. Weight 4.9kg (clamp shoes in illustration not included).

No 20 150

**NOTE:**  
The motor operates at 40V, supplied from the power pack/controller. At this level, the control characteristics are ideal and yield high torque, even at lower speeds. (The compound table, drill stand and step clamps are not included).



BFB 2000  
see page 51

**The Mill/Drill unit BFB 2000, with tilting headstock and 140mm throat depth.**

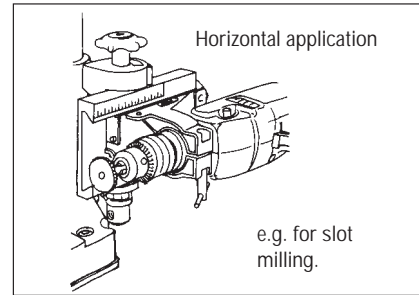
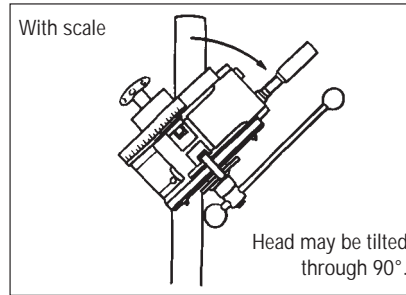
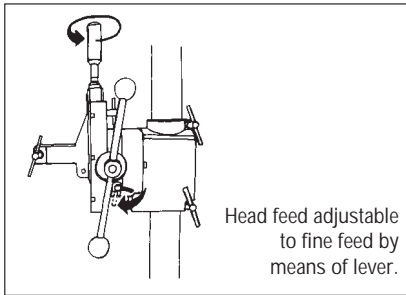

Head with precision milled dovetail slide and may be tilted through 90° to give all-round versatility: diagonal drilling, versatile without need of special milling bits, milling diagonal slots.

Fine feed selectable, allowing fine head feed for milling. With dial and depth scale. Geared rack and pinion feed for effortless drilling with 65mm stroke. 45mm diameter drill column, 500mm long. Approx. 140mm throat. Machined, solid base plate approx. 200 x 200mm. All drills with standard 43mm spindle collars may be utilised directly: BOSCH, AEG, FEIN, METABO, KRESS, BLACK & DECKER, SKIL. Approx. weight 6.5kg. No 20 000

**High speed steel end mills. Suitable for drill and mill system BFW 40/E**

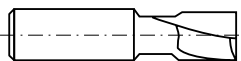

1 each of 2, 3, 4 and 5mm. All with 6mm shaft to fit collet in BFW 40/E. Double flute to German industrial standard DIN 327. Supplied in wooden box.

No 24 610

**Milled multi-step clamp set**

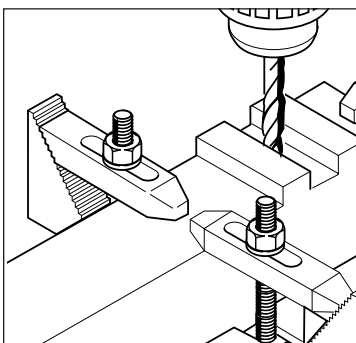

Set includes 2 stepped blocks, 2 clamp blocks, 2 studs, 2 special nuts for use in T-slots and 2 nuts. Fits compound table KT 150 (illustrated), miller FF 400 and milling machine PF 400. Accepts workpieces up to approx. 35mm thick.

No 24 257

*Additional accessories are depicted on page 45!*

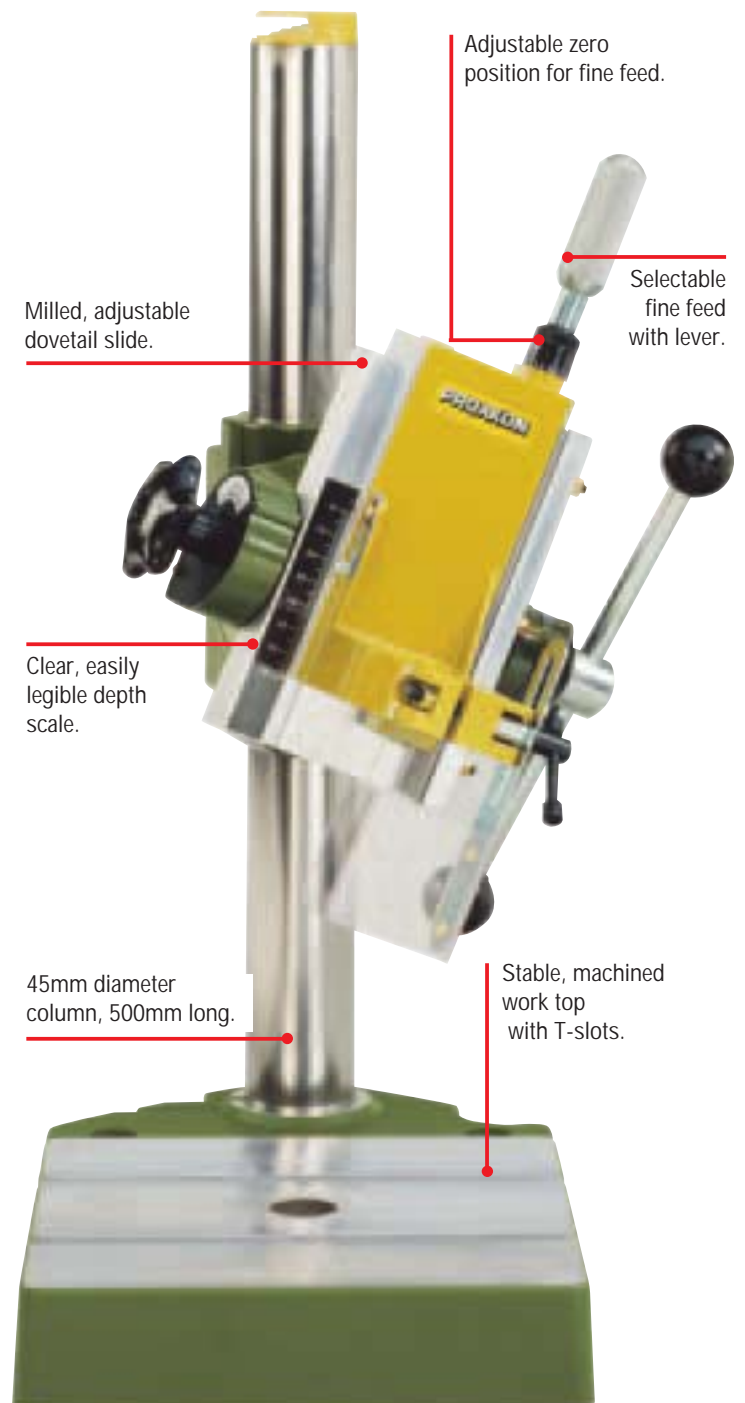



"WE RESERVE THE RIGHT TO MODIFY/IMPROVE ITEMS WITHOUT PRIOR NOTIFICATION. E & O E."

## **X-ON Electronics**

Largest Supplier of Electrical and Electronic Components

*Click to view similar products for [proxxon](#) manufacturer:*

Other Similar products are found below :

[PRN28510](#) [KT 70](#) [24152](#) [28752](#) [28910](#) [PR23100](#) [PR23296](#) [28017](#) [PR23084](#) [PRN28706](#) [PR28731](#) [23286](#) [PRN23604](#) [PRN23000](#)  
[PRN28472](#) [MICROMOT 110/P](#) [MC 10](#) [24154](#) [28856](#) [28858](#) [23821](#) [PRN23090](#) [27100](#) [28600](#) [23820](#) [TBM 220](#) [28874](#) [PRN28515](#) [PR23350](#)  
[28750](#) [28720](#) [PRN20392](#) [28810](#) [PRN23040](#) [28852](#) [28854](#) [28842](#) [MC 2](#) [PR23822](#) [28941](#) [PR23821](#) [PR28610](#) [PR28608](#) [PRN28820](#)  
[PRN23080](#) [PR28602](#) [28582](#) [28148](#) [28759](#) [28761](#)