

**Product Description**

The PE42423 is a HaRP™ technology-enhanced absorptive 50Ω SPDT RF switch designed for use in high power and high performance WLAN 802.11 a/b/g/n/ac applications such as carrier and enterprise Wi-Fi Products, supporting bandwidths up to 6 GHz.

This switch features high linearity which remains invariant across the full supply range. PE42423 also features exceptional isolation, high power handling and is offered in a 16-lead 3x3 mm QFN package. In addition, no external blocking capacitors are required if 0V DC is present on the RF ports.

The PE42423 is manufactured on Psemi's UltraCMOS® process, a patented variation of silicon-on-insulator (SOI) technology on a sapphire substrate.

Psemi's HaRP™ technology enhancements deliver high linearity and excellent harmonics performance. It is an innovative feature of the UltraCMOS® process, offering the performance of GaAs with the economy and integration of conventional CMOS.

**Features**

- 802.11 a/b/g/n/ac support
- Wide supply range of 2.3V to 5.5V
- +1.8V control logic compatible
- Exceptional isolation
  - 47 dB @ 2.4 GHz
  - 43 dB @ 6.0 GHz
- High linearity across supply range
  - IIP3 of 65 dBm
  - IIP2 of 120 dBm
- High power handling
  - 38.5 dBm @ 2.4 GHz
  - 37.0 dBm @ 6.0 GHz
- Fast switching time of 500 ns
- ESD performance
  - 3kV HBM on RF pins to GND
  - 1.5kV HBM on all pins
  - 1kV CDM on all pins

**Figure 1. Functional Diagram**

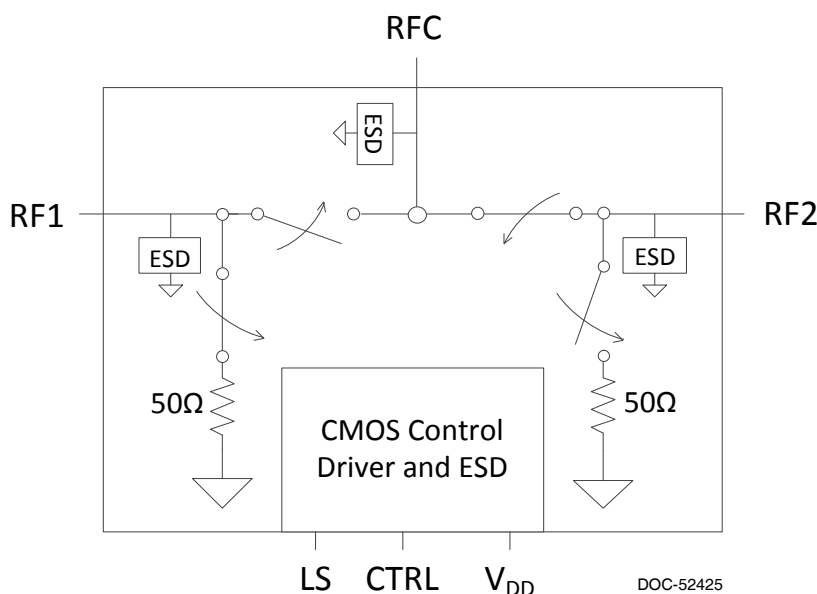

**Figure 2. Package Type**

16-lead 3x3 mm QFN

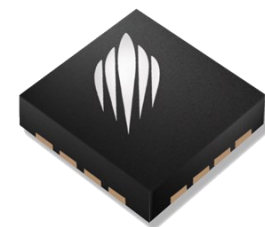
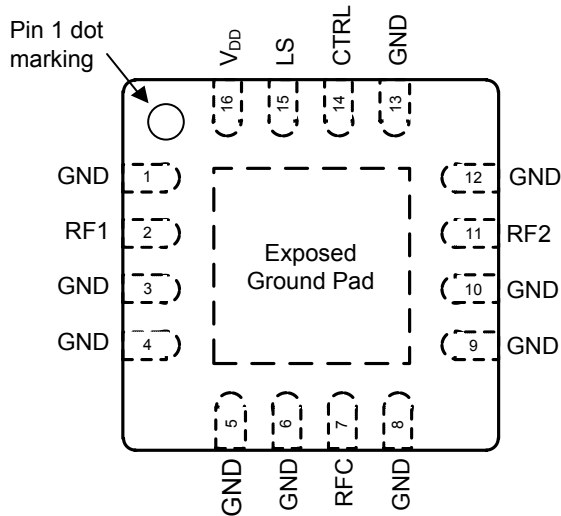

**Table 1. Electrical Specifications Temp = 25°C, V<sub>DD</sub> = 3.3V**

Parameter	Path	Condition	Min	Typ	Max	Unit
Operational frequency			0.1		6	GHz
Insertion loss	RFC–RFX	0.1–2.4 GHz		0.80	1.0	dB
		2.4–5.8 GHz		0.95	1.1	dB
		5.8–6.0 GHz		0.95	1.1	dB
Isolation	RFX–RFX	0.1–2.4 GHz	49	51		dB
		2.4–5.8 GHz	39	41		dB
		5.8–6.0 GHz	39	41		dB
Isolation	RFC–RFX	0.1–2.4 GHz	44	47		dB
		2.4–5.8 GHz	39	41		dB
		5.8–6.0 GHz	40	43		dB
Return loss (common and active port)	RFX	0.1–2.4 GHz		19		dB
		2.4–5.8 GHz		16		dB
		5.8–6.0 GHz		16		dB
Return loss (terminated port)	RFX	0.1–2.4 GHz		23		dB
		2.4–5.8 GHz		23		dB
		5.8–6.0 GHz		24		dB
Input 0.1 dB compression point <sup>1</sup>	RFC–RFX	0.6–4.0 GHz		39.5		dBm
Input IP3 <sup>2</sup>	RFC–RFX	0.8–2.7 GHz		65		dBm
Input IP2 <sup>2</sup>	RFC–RFX	0.8–2.7 GHz		120		dBm
Switching time		50% CTRL to 90% or 10% of final value		500	700	ns

Notes: 1. The input 0.1dB compression point is a linearity figure of merit. Refer to *Table 3* for the operating RF input power (50 $\mu$ W).  
2. The input intercept point remains invariant over the full supply range as defined in *Table 3*.

**Figure 3. Pin Configuration (Top View)**



**Table 2. Pin Descriptions**

Pin #	Pin Name	Description
1, 3, 4, 5, 6, 8, 9, 10, 12, 13	GND	Ground
2	RF1 <sup>1</sup>	RF port 1
7	RFC <sup>1</sup>	RF common
11	RF2 <sup>1</sup>	RF port 2
14	CTRL	Digital control logic input
15	LS	Logic Select - used to determine the definition for the CTRL pin (see Table 5)
16	V <sub>DD</sub>	Supply voltage (nominal 3.3V)
Pad	GND	Exposed pad: ground for proper operation

Note 1: RF pins 2, 7 and 11 must be at 0V DC. The RF pins do not require DC blocking capacitors for proper operation if the 0V DC requirement is met

**Table 3. Operating Ranges**

Parameter	Symbol	Min	Typ	Max	Unit
Supply voltage	V <sub>DD</sub>	2.3		5.5	V
Supply current	I <sub>DD</sub>		120	200	μA
Digital input high (CTRL)	V <sub>IH</sub>	1.17		3.6	V
Digital input low (CTRL)	V <sub>IL</sub>	-0.3		0.6	V
RF input power, CW 0.1–0.6 GHz 0.6–4.0 GHz 4.0–6.0 GHz	P <sub>MAX,CW</sub>			27 Fig. 4 Fig. 4	dBm dBm dBm
RF input power, pulsed <sup>1</sup> 0.1–0.6 GHz 0.6–4.0 GHz 4.0–6.0 GHz	P <sub>MAX,PULSED</sub>			27 Fig. 4 Fig. 4	dBm dBm dBm
RF input power into terminated ports, CW	P <sub>MAX,TERM</sub>			22	dBm
Operating temperature range	T <sub>OP</sub>	-40	+25	+125	°C

Note 1: Pulsed, 5% duty cycle of 4620 μs period, 50μs

**Table 4. Absolute Maximum Ratings**

Parameter/Condition	Symbol	Min	Max	Unit
Supply voltage	V <sub>DD</sub>	-0.3	5.5	V
Digital input voltage (CTRL)	V <sub>CTRL</sub>	-0.3	3.6	V
LS input voltage	V <sub>LS</sub>	-0.3	3.6	V
Maximum input power 0.1–0.6 GHz 0.6–4.0 GHz 4.0–6.0 GHz	P <sub>MAX,ABS</sub>		30 39 37.5	dBm dBm dBm
Storage temperature range	T <sub>ST</sub>	-65	+150	°C
ESD voltage HBM <sup>1</sup> RF pins to GND All pins	V <sub>ESD,HBM</sub>		3000 1500	V V
ESD voltage MM <sup>2</sup> , all pins	V <sub>ESD,MM</sub>		200	V
ESD voltage CDM <sup>3</sup> , all pins	V <sub>ESD,CDM</sub>		1000	V

Notes: 1. Human Body Model (MIL-STD 883 Method 3015)  
2. Machine Model (JEDEC JESD22-A115)  
3. Charged Device Model (JEDEC JESD22-C101)

Exceeding absolute maximum ratings may cause permanent damage. Operation should be restricted to the limits in the Operating Ranges table. Operation between operating range maximum and absolute maximum for extended periods may reduce reliability.

### Electrostatic Discharge (ESD) Precautions

When handling this UltraCMOS<sup>®</sup> device, observe the same precautions that you would use with other ESD-sensitive devices. Although this device contains circuitry to protect it from damage due to ESD, precautions should be taken to avoid exceeding the rating specified.

### Latch-Up Avoidance

Unlike conventional CMOS devices, UltraCMOS<sup>®</sup> devices are immune to latch-up.

### Switching Frequency

The PE42423 has a maximum 25 kHz switching rate. Switching frequency describes the time duration between switching events. Switching time is the time duration between the point the control signal reaches 50% of the final value and the point the output signal reaches within 10% or 90% of its target value.

**Table 5. Control Logic Truth Table**

LS	CTRL	RFC-RF1	RFC-RF2
0	0	off	on
0	1	on	off
1	0	on	off
1	1	off	on

### Moisture Sensitivity Level

The Moisture Sensitivity Level rating for the PE42423 in the 16-lead 3x3 mm QFN package is MSL3.

### Logic Select (LS)

The Logic Select feature is used to determine the definition for the CTRL pin.

**Figure 4. Power De-rating Curve for 600 MHz – 6 GHz**

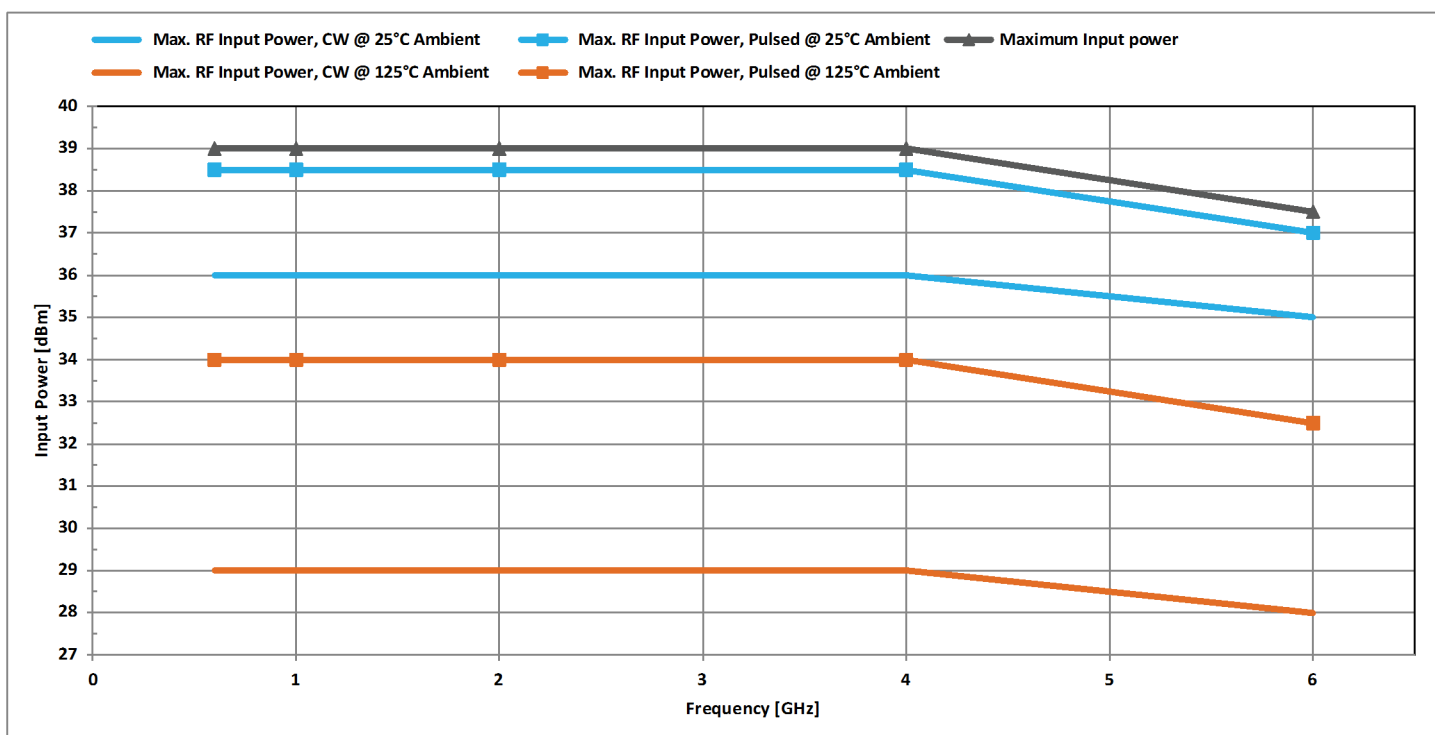

Typical Performance Data @ 25°C and  $V_{DD} = 3.3V$  unless otherwise specified

Figure 5. Insertion Loss vs. Temp (RFC–RFX)

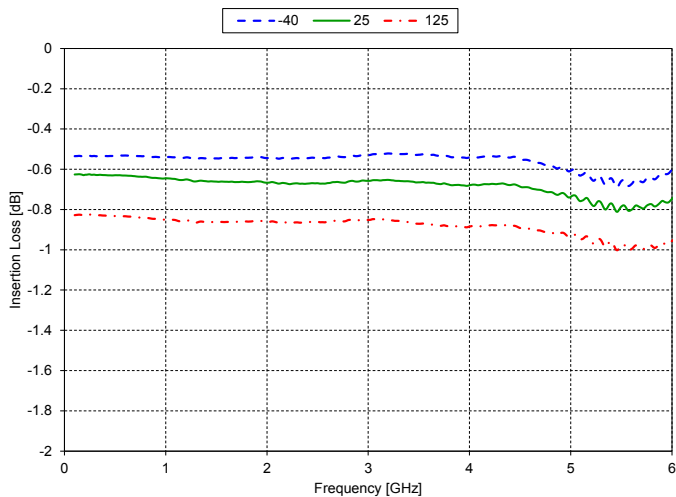

Figure 6. Insertion Loss vs.  $V_{DD}$  (RFC–RFX)

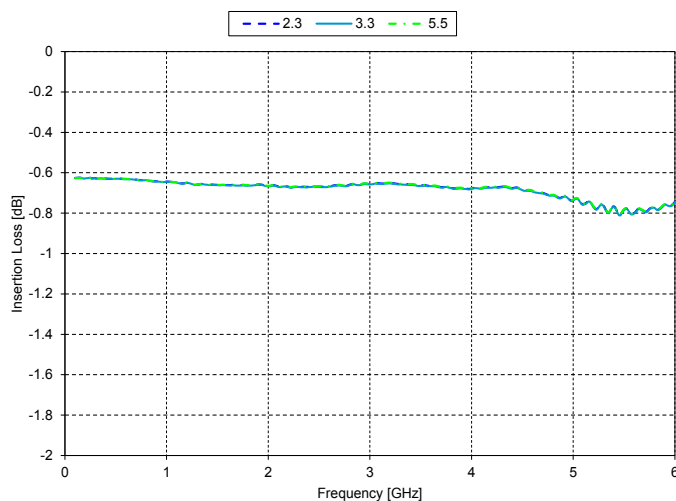

Figure 7. RFX Port Return Loss vs. Temp

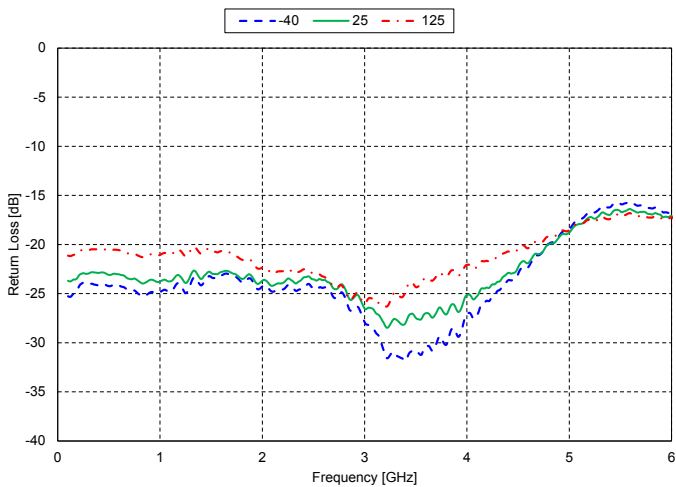
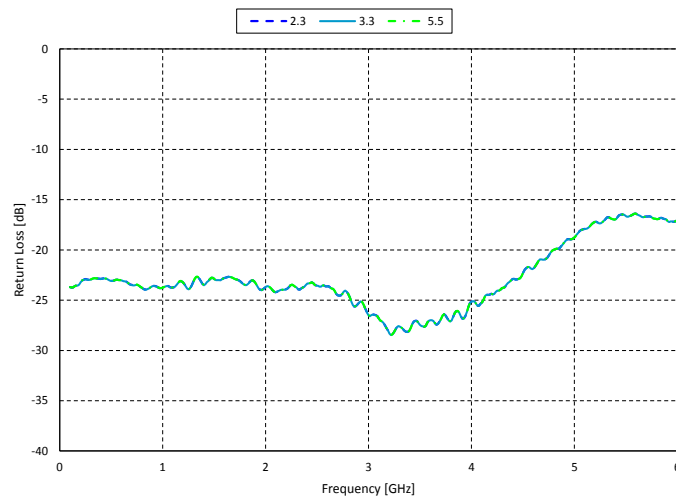
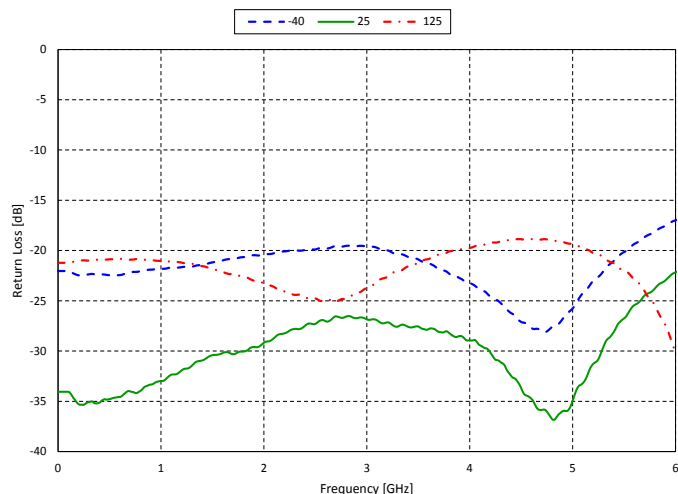

Figure 8. RFX Port Return Loss vs.  $V_{DD}$



Typical Performance Data @ 25°C and  $V_{DD} = 3.3V$  unless otherwise specified

**Figure 9. Terminated Port Return Loss vs. Temp (RFX Active)**



**Figure 10. Terminated Port Return Loss vs.  $V_{DD}$  (RFX Active)**

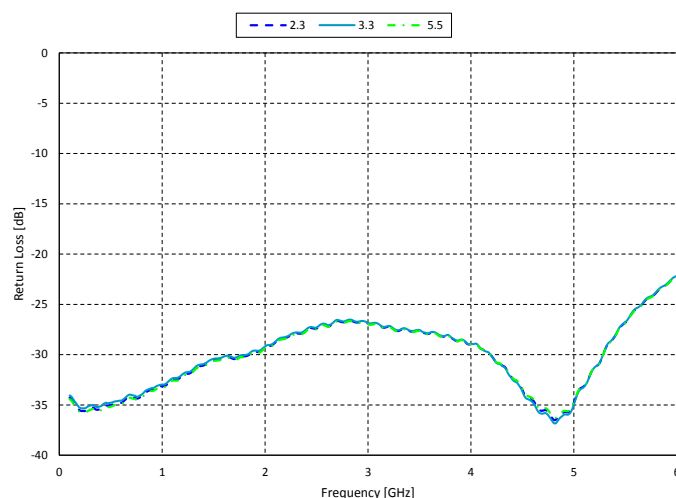

**Figure 11. Isolation vs. Temp (RFX-RFX, RFX Active)**

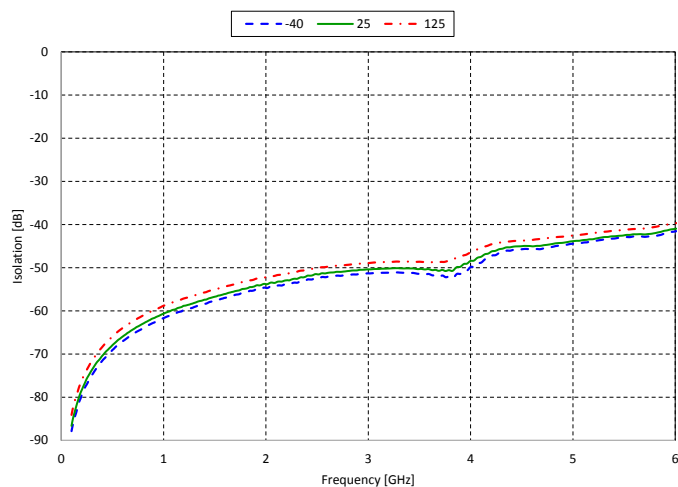

**Figure 12. Isolation vs.  $V_{DD}$  (RFX-RFX, RFX Active)**

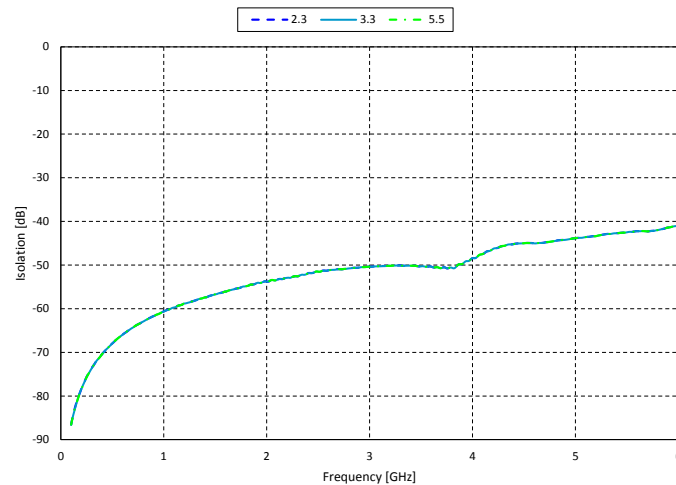

Typical Performance Data @ 25°C and  $V_{DD} = 3.3V$  unless otherwise specified

Figure 13. Isolation vs. Temp  
(RFC–RFX, RFX Active)

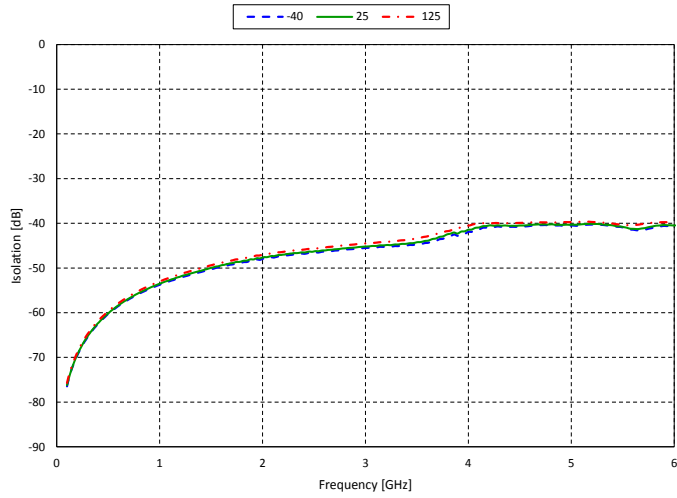
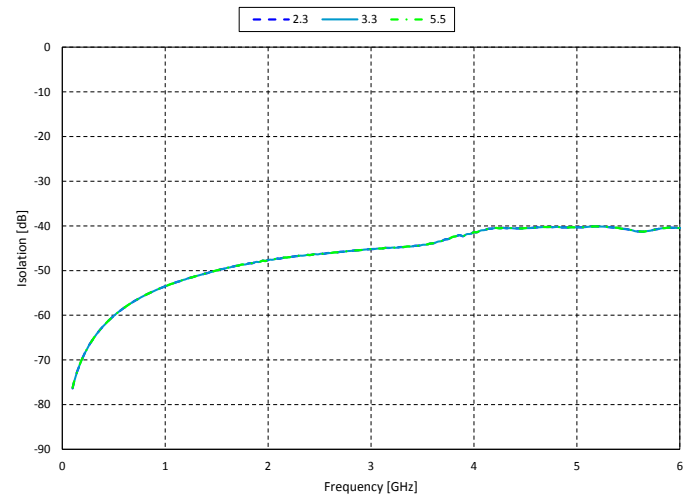

Figure 14. Isolation vs.  $V_{DD}$   
(RFC–RFX, RFX Active)



### Evaluation Kit

The SPDT switch evaluation board was designed to ease customer evaluation of PSEMI's PE42423. The RF common port is connected through a 50Ω transmission line via the SMA connector, J1. RF1 and RF2 ports are connected through 50Ω transmission lines via SMA connectors J2 and J3, respectively. A 50Ω through transmission line is available via SMA connectors J5 and J6, which can be used to de-embed the loss of the PCB. J4 provides DC and digital inputs to the device.

For the true performance of the PE42423 to be realized, the PCB should be designed in such a way that RF transmission lines and sensitive DC I/O traces are heavily isolated from one another.

**Figure 15. Evaluation Kit Layout**

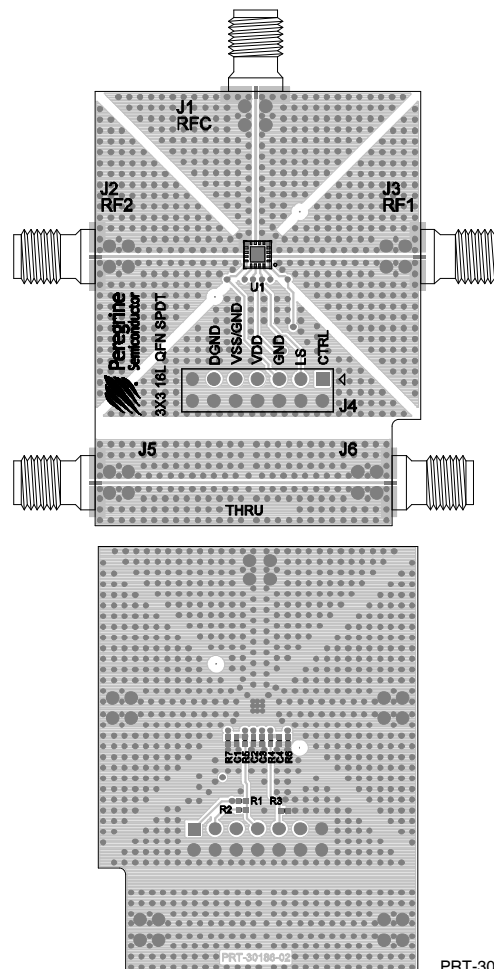

PRT-30186



Figure 16. Evaluation Board Schematic

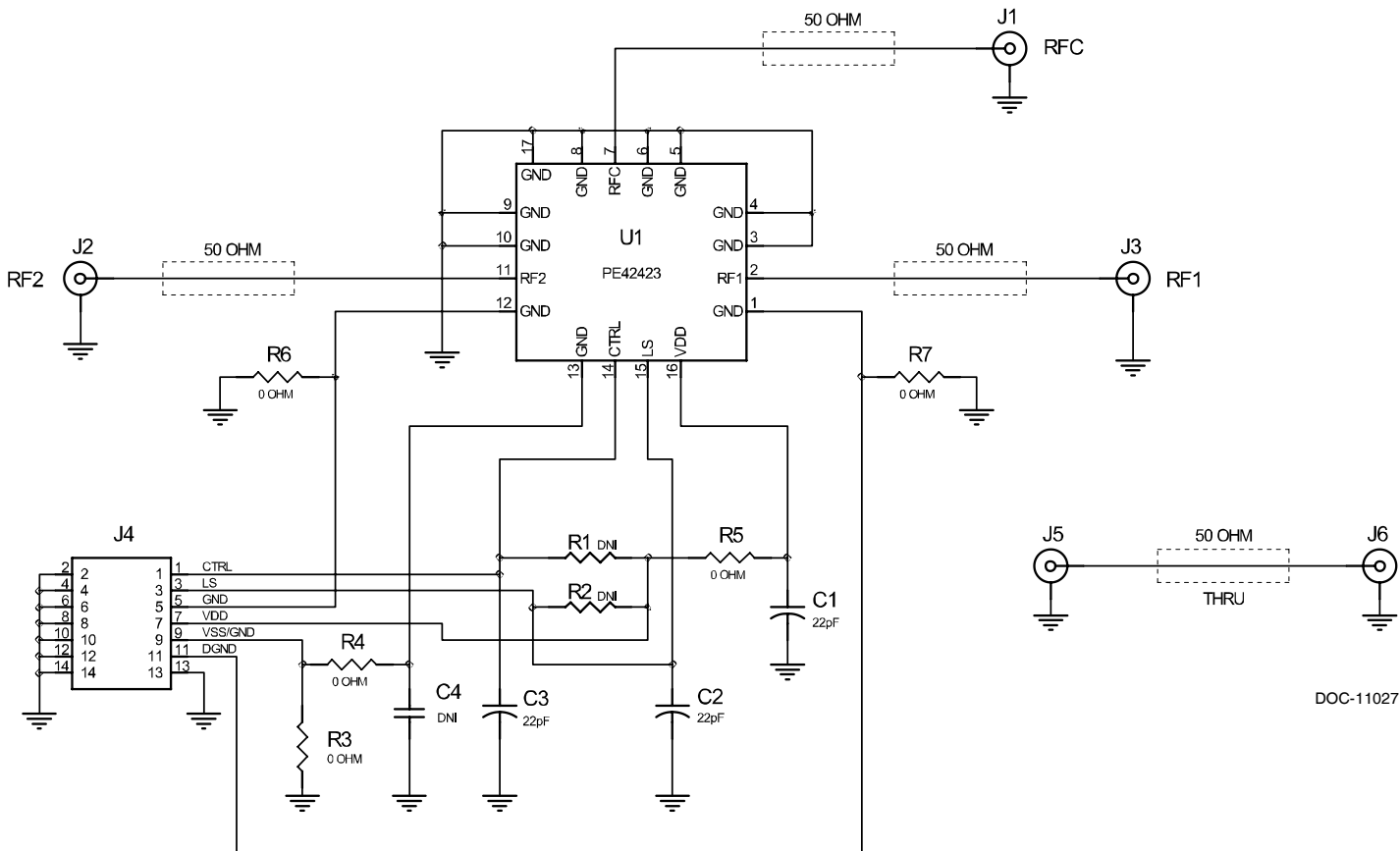

DOC-11027

- Notes:
1. Use PRT-30186-2 PCB
  2. CAUTION: Contains parts and assemblies susceptible to damage by electrostatic discharge (ESD)

**Figure 17. Package Drawing**  
16-lead 3x3 mm QFN

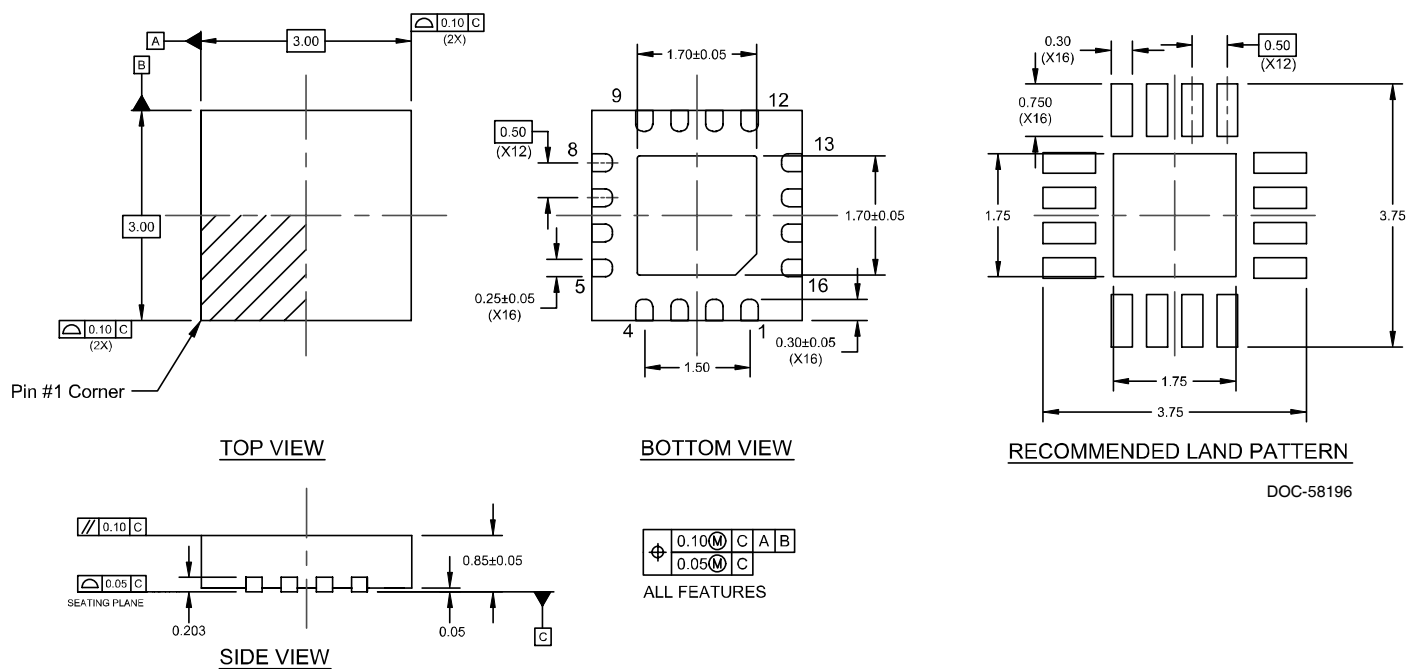

**Figure 18. Top Marking Specifications**

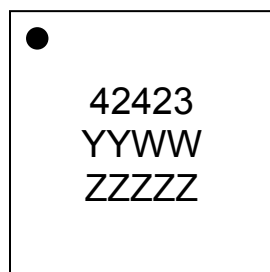

- = Pin 1 designator
- YYWW = Date code
- ZZZZZ = Last five digits of lot number

17-0009

Figure 19. Tape and Reel Specifications

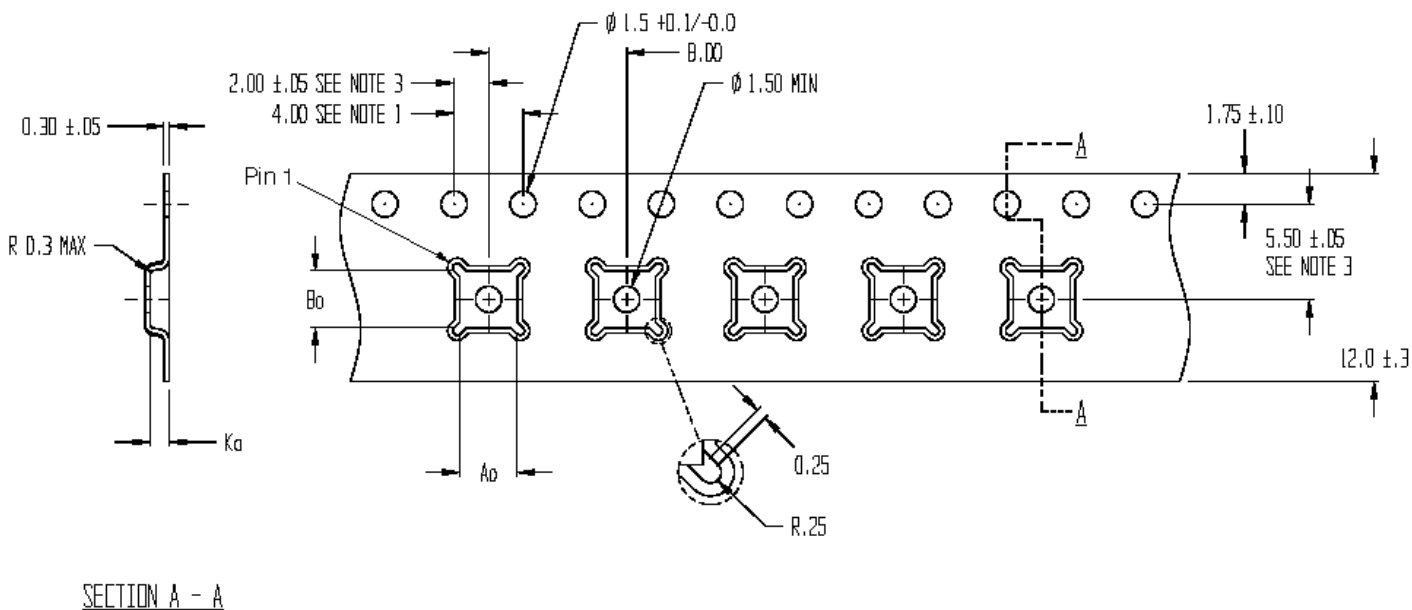

- Notes: 1. 10 sprocket hole pitch cumulative tolerance  $\pm 0.2$   
 2. Camber in compliance with EIA 481  
 3. Pocket position relative to sprocket hole measured as true position of pocket, not pocket hole

$A_o = 3.30$   
 $B_o = 3.30$   
 $K_o = 1.10$

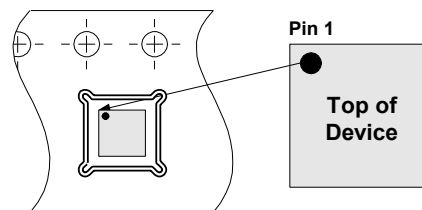

Device Orientation in Tape

Table 6. Ordering Information

Order Code	Description	Package	Shipping Method
PE42423B-Z	PE42423 SPDT RF switch	Green 16-lead 3x3 mm QFN	3000 units/T&R
EK42423-03	PE42423 Evaluation kit	Evaluation kit	1/Box

## Sales Contact and Information

For sales and contact information please visit [www.psemi.com](http://www.psemi.com).

**Advance Information:** The product is in a formative or design stage. The datasheet contains design target specifications for product development. Specifications and features may change in any manner without notice.

**Preliminary Specification:** The datasheet contains preliminary data. Additional data may be added at a later date. pSemi reserves the right to change specifications at any time without notice in order to supply the best possible product. **Product Specification:** The datasheet contains final data. In the event pSemi decides to change the specifications, pSemi will notify customers of the intended changes by issuing a CNF (Customer Notification Form).

The information in this document is believed to be reliable. However, pSemi assumes no liability for the use of this information. Use shall be entirely at the user's own risk.

No patent rights or licenses to any circuits described in this document are implied or granted to any third party. pSemi's products are not designed or intended for use in devices or systems intended for surgical implant, or in other applications intended to support or sustain life, or in any application in which the failure of the pSemi product could create a situation in which personal injury or death might occur. pSemi assumes no liability for damages, including consequential or incidental damages, arising out of the use of its products in such applications.

The Peregrine Semiconductor name, Peregrine Semiconductor logo and UltraCMOS are registered trademarks and the pSemi name, pSemi logo, HaRP and DuNE are trademarks of pSemi Corporation in the U.S. and other countries.

pSemi products are protected under one or more of the following U.S. patents: [patents.psemi.com](http://patents.psemi.com).

## X-ON Electronics

Largest Supplier of Electrical and Electronic Components

*Click to view similar products for [WiFi Development Tools - 802.11 category](#):*

*Click to view products by [pSemi manufacturer](#):*

Other Similar products are found below :

[YSAEWIFI-1](#) [SKY65981-11EK1](#) [QPF7221PCK-01](#) [SIMSA915C-Cloud-DKL](#) [SIMSA433C-Cloud-DKL](#) [ISM43903-R48-EVB-E](#)  
[QPF4206BEVB01](#) [RN-G2SDK](#) [SKY85734-11EK1](#) [SKY85735-11EK1](#) [ENW49D01AZKF](#) [ESP-LAUNCHER](#) [MIKROE-2336](#)  
[EVAL\\_PAN1760EMK](#) [EVAL\\_PAN1026EMK](#) [ATWINC1500-XPRO](#) [2471](#) [DM990001](#) [WRL-13711](#) [2999](#) [ATWILC3000-SHLD](#) [DFR0321](#)  
[TEL0118](#) [3213](#) [DFR0489](#) [SLWSTK-COEXBP](#) [WRL-13804](#) [DEV-13907](#) [UP-3GHAT-A20-0001](#) [3405](#) [TEL0078](#) [2680](#) [2702](#) [2821](#) [3044](#)  
[3606](#) [3653](#) [3654](#) [4000](#) [4172](#) [4178](#) [4201](#) [4264](#) [4285](#) [CS-ANAVI-25](#) [CS-ANAVI-26](#) [CS-ANAVI-23](#) [CS-ANAVI-24](#) [CS-ANAVI-28](#) [CS-ANAVI-29](#)