

PE42545

Document Category: Product Specification

UltraCMOS® SP4T RF Switch, 9 kHz–67 GHz



Features

- Wideband support up to 67 GHz
- Low insertion loss of 2.6 dB @ 45 GHz
- Fast switching time of 75 ns
- High input P1dB of 33.5 dBm
- Low return loss of 20 dB @ 60 GHz
- -40 °C to +105 °C operating temperature support
- Package: Flip-chip die

Applications

- Test and measurement (T&M)
- 5G mmWave
- Microwave backhaul
- Radar
- Satellite communications

Figure 1 ■ PE42545 Functional Diagram

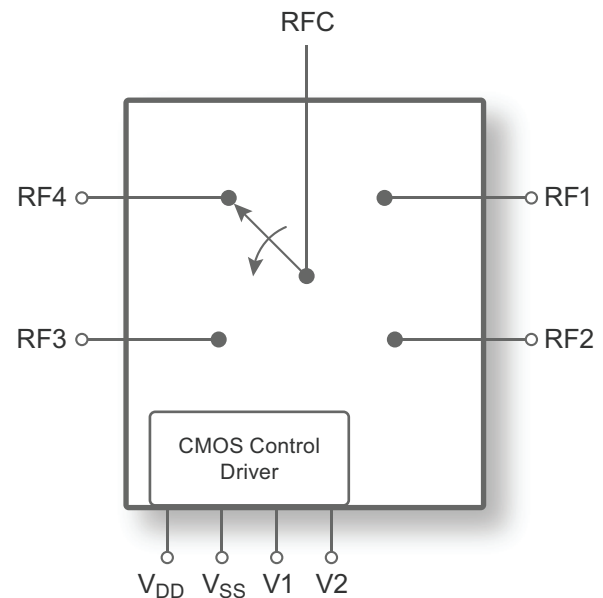

Product Description

The PE42545 is a HaRP™ technology-enhanced reflective SP4T RF switch die that supports a wide frequency range from 9 kHz to 67 GHz. It delivers low insertion loss, fast switching time and high isolation performance, making this device ideal for test and measurement (T&M), 5G mmWave, microwave backhaul, radar and satellite communication applications. No blocking capacitors are required if DC voltage is not present on the RF ports.

The PE42545 is manufactured on pSemi's UltraCMOS® process, a patented variation of silicon-on-insulator (SOI) technology.

Absolute Maximum Ratings

Exceeding absolute maximum ratings listed in **Table 1** may cause permanent damage. Operation should be restricted to the limits in **Table 2**. Operation between operating range maximum and absolute maximum for extended periods may reduce reliability.

ESD Precautions

When handling this UltraCMOS device, observe the same precautions as with any other ESD-sensitive devices. Although this device contains circuitry to protect it from damage due to ESD, precautions should be taken to avoid exceeding the rating specified in **Table 1**.

Latch-up Immunity

Unlike conventional CMOS devices, UltraCMOS devices are immune to latch-up.

Table 1 ■ Absolute Maximum Ratings for PE42545

Parameter/Condition	Min	Max	Unit
V _{DD} Positive Supply Voltage	-0.3	3.6	V
V _{SS} Negative Supply Voltage	-3.6	0.3	V
Digital Input Voltage	-0.3	V _{DD} +0.3	V
Storage Temperature	-65	150	°C
Human-Body Model, All Pins Except RF		2000	V
Human-Body Model, RF Pins		600	V

Recommended Operating Conditions

Table 2 lists the recommending operating conditions for the PE42545. Devices should not be operated outside the operating conditions listed below.

Table 2 ▪ *Recommended Operating Conditions for PE42545*

Parameter	Min	Typ	Max	Unit
VDD Positive Supply Voltage	3.15	3.3	3.45	V
VSS Negative Supply Voltage	-3.45	-3.3	-3.15	V
IDD Positive Supply Current		3		μA
ISS Negative Supply Current		-110		μA
Control Voltage High	1.2		3.3	V
Control Voltage Low	0		0.8	V
Digital Input Leakage Current			35	μA
RF Input Power, CW (RFC-RFX)			Fig. 2	dBm
RF Input Power, Pulsed (RFC-RFX)			Fig. 2	dBm
Temperature Range	-40	25	105	°C

Electrical Specifications

Table 3 provides the PE42545 key electrical specifications @ +25 °C, $V_{DD} = 3.3V$, unless otherwise specified.

Table 3 ■ Electrical Specifications for PE42545

Parameters	Description	Frequency (MHz)	Min	Typ	Max	Unit
Insertion Loss		10		1.0	1.3	dB
		10 to 18000		1.7	2.2	dB
		18000 to 35000		2.1	2.7	dB
		35000 to 40000		2.4	2.9	dB
		40000 to 45000		2.6	3.1	dB
		45000 to 60000		3.2	3.8	dB
		60000 to 64000		3.7	4.9	dB
Isolation	RFC to RFX	10 to 18000	43	46		dB
		18000 to 35000	31	40		dB
		35000 to 40000	34	38		dB
		40000 to 45000	32	36		dB
		45000 to 60000	23	28		dB
		60000 to 67000	22.5	26		dB
	RFX to RFX	10 to 18000	39	41		dB
		18000 to 35000	35	37		dB
		35000 to 40000	30	35		dB
		40000 to 45000	30	33		dB
		45000 to 60000	21	26		dB
		60000 to 67000	20	23		dB
Return Loss (common port)		10 to 8000		15		dB
		8000 to 30000		13		dB
		30000 to 35000		17		dB
		35000 to 45000		22		dB
		45000 to 60000		20		dB
		60000 to 64000		15		dB
		64000 to 67000		10		dB

Table 3 ■ Electrical Specifications for PE42545

Parameters	Description	Frequency (MHz)	Min	Typ	Max	Unit
Return Loss (Active Port)		10 to 35000		18		dB
		35000 to 45000		16		dB
		45000 to 60000		14		dB
		60000 to 64000		15		dB
		64000 to 67000		13		dB
0.1 dB Compression		14 GHz		28		dBm
1 dB Compression		14 GHz		33.5		dBm
Input IP2		100		103		dBm
		746		103		dBm
		1974		110		dBm
		2635		113		dBm
Input IP3		746		52		dBm
		1974		52		dBm
		2635		51		dBm
		24900		50		dBm
		40200		50		dBm
		47900		50		dBm
Switching time	50% VCTL to 10% to 90% of RF output			75		nsec

Power De-rating Curve

Figure 2 shows the power de-rating curve for the PE42545 from 10 kHz–67 GHz @ –40°C to +105 °C ambient, (50Ω).

Figure 2 ▪ Power De-rating Curve for PE42545

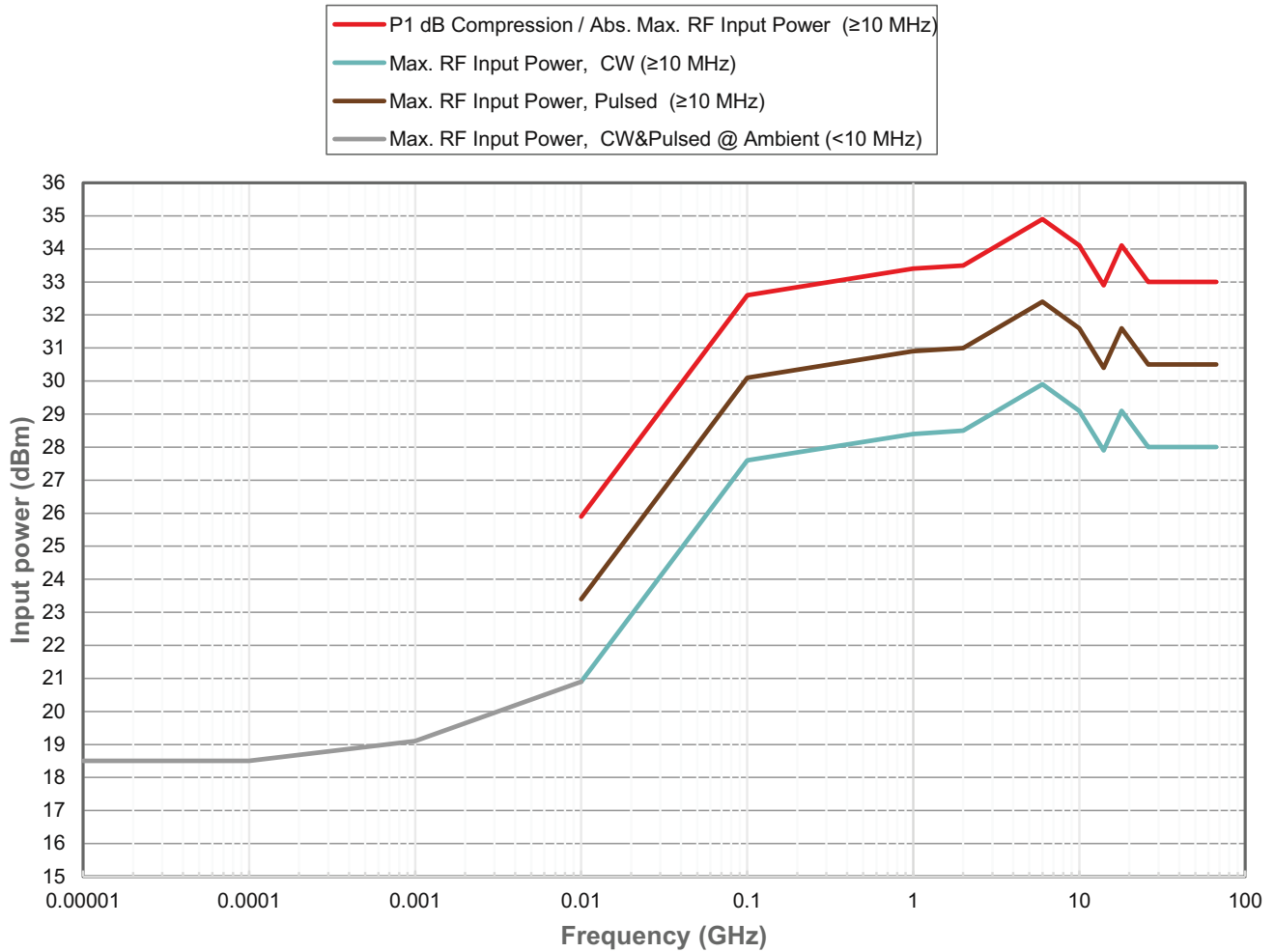

Typical Performance Data Using Probe PCB

Figure 3–Figure 19 show the typical performance data at 25 °C, VDD = +3.3V, VSS = –3.3V (ZS = ZL = 50Ω), unless otherwise specified.

Figure 3 ■ Insertion Loss (RFC-RFX)

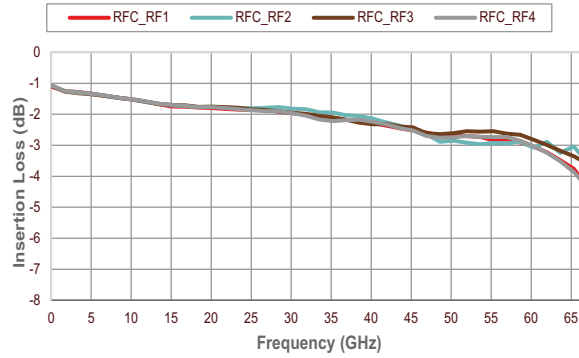

Figure 4 ■ Insertion Loss vs. Temperature (RFC-RF1)

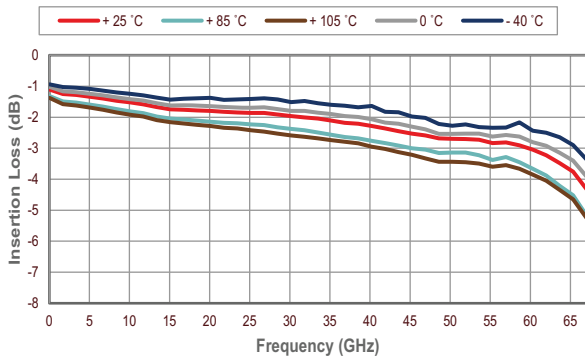

Figure 5 ■ Insertion Loss vs. Temperature (RFC-RF2)

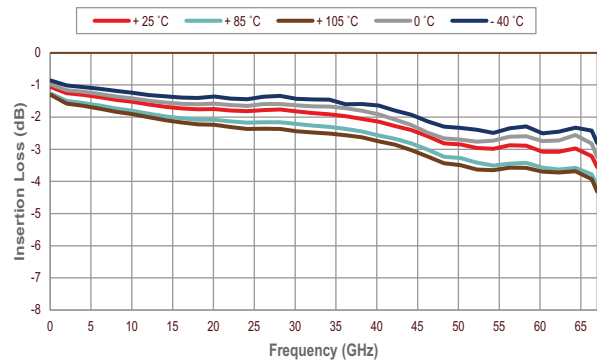

Figure 6 ■ Insertion Loss vs. VDD/VSS (RFC-RF1)

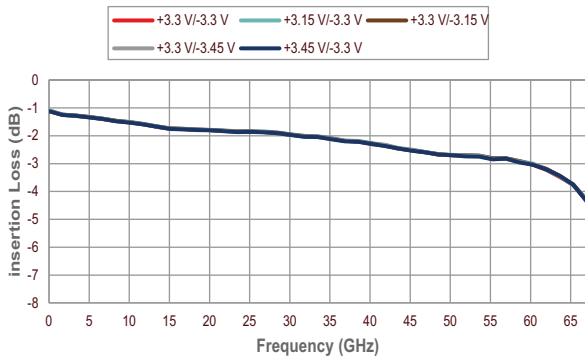

Figure 7 ■ Insertion Loss vs. VDD/VSS (RFC-RF2)

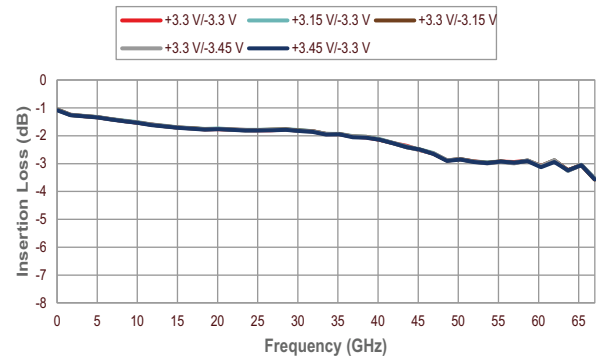

Figure 8 ■ Return Loss Common Port (RFX ON)

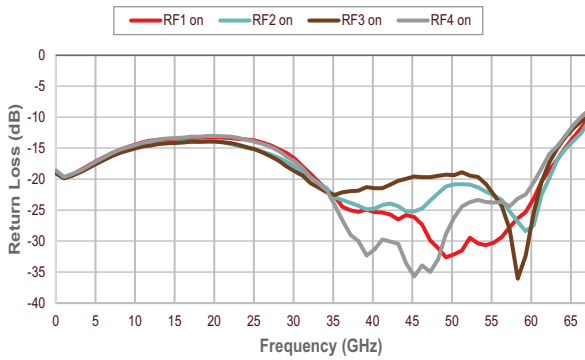

Figure 9 ■ Return Loss Active Port (RFX ON)

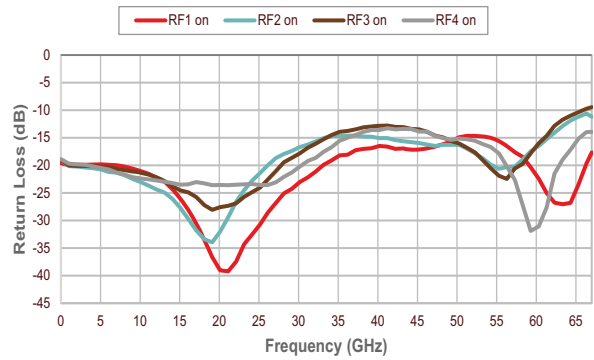

Figure 10 ■ Isolation (RFC-RFX)

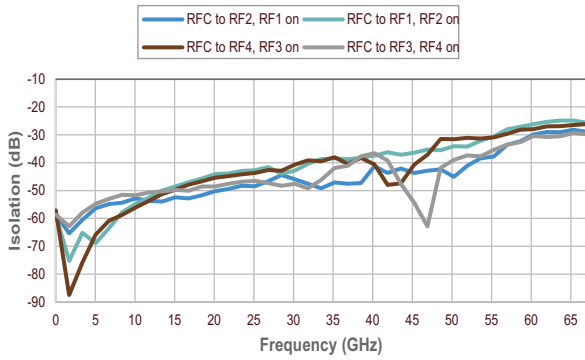

Figure 11 ■ Isolation (RFX-RFX)

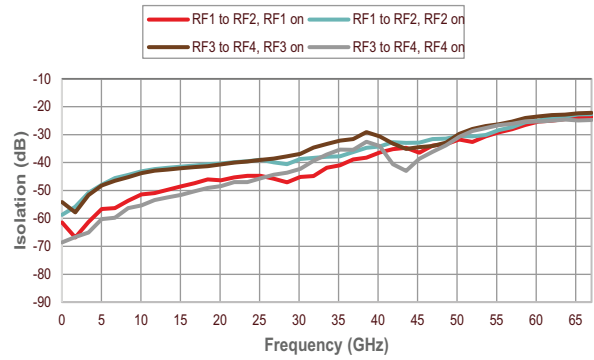

Figure 12 ■ Isolation vs. Temperature (RFC-RF2, Active Port: RF1)

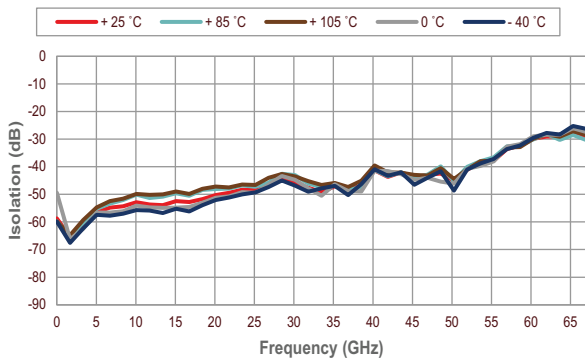

Figure 13 ■ Isolation vs. Temperature (RF1-RF2, Active Port: RF1)

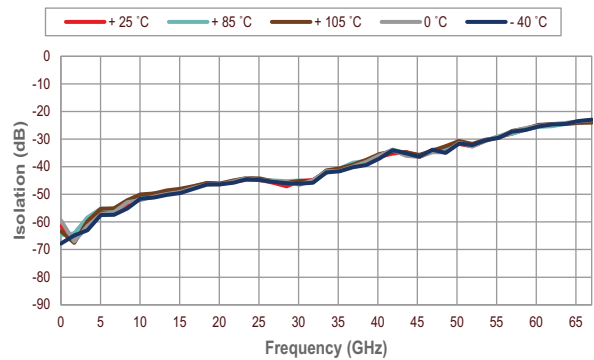

Figure 14 ■ Isolation vs. VDD/VSS (RFC-RF2, Active Port: RF1)

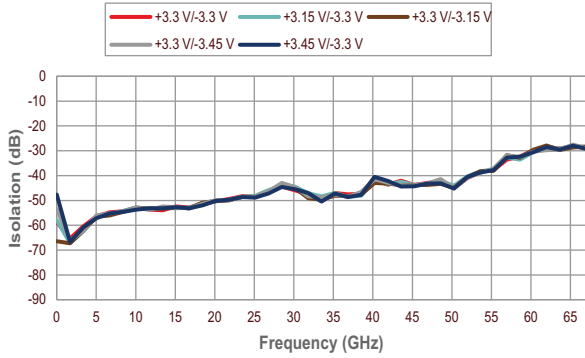

Figure 15 ■ Isolation vs. VDD/VSS (RF1-RF2, Active Port: RF1)

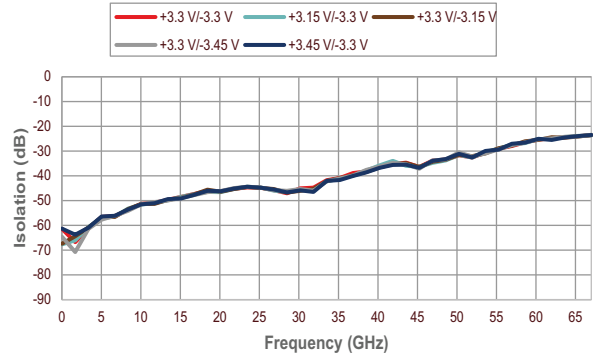

Figure 16 ■ Isolation vs. Temperature (RFC-RF1, Active Port: RF2)

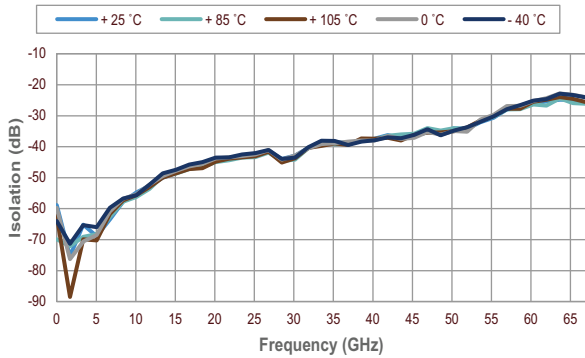

Figure 17 ■ Isolation vs. Temperature (RF1-RF2, Active Port: RF2)

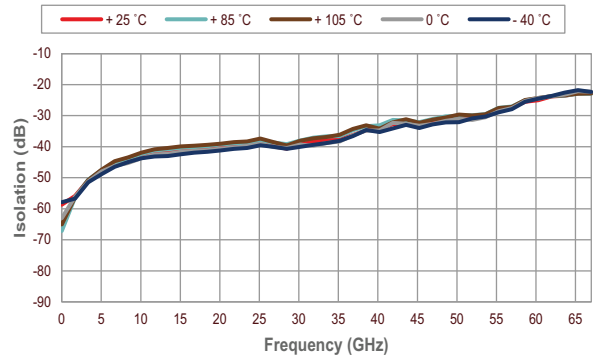

Figure 18 ■ Isolation vs. VDD/VSS (RFC-RF1, Active Port: RF2)

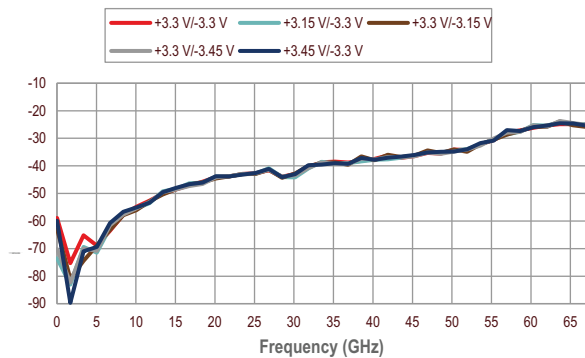
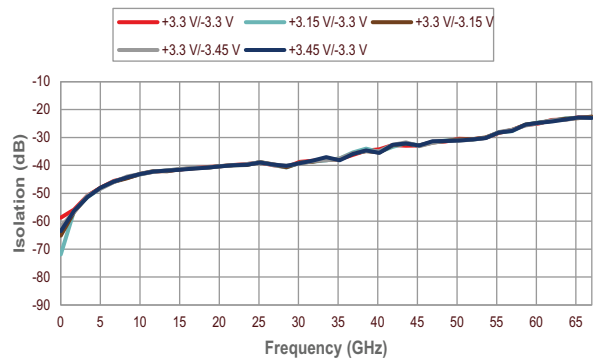

Figure 19 ■ Isolation vs. VDD/VSS (RF1-RF2, Active Port: RF2)



Typical Performance Data Using a Connectorized EVK PCB

Figure 20–Figure 25 show the typical performance data at 25 °C, VDD = +3.3V, VSS = –3.3V (ZS = ZL = 50Ω), unless otherwise specified.

Figure 20 ■ Insertion Loss (RFC-RF1/RFC-RF4)

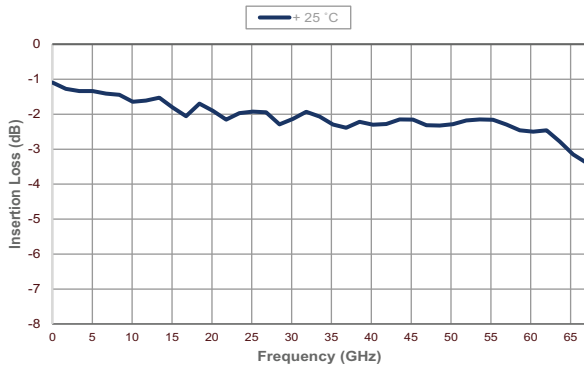

Figure 21 ■ Insertion Loss (RFC-RF2/RFC-RF3)

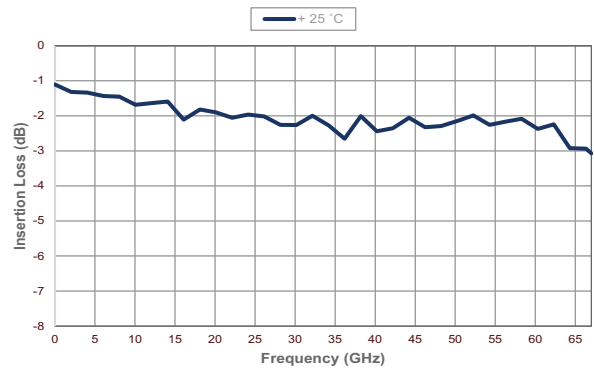

Figure 22 ■ Isolation (RFC-RF2, Active Port: RF1; or RFC to RF3, Active Port: RF4)

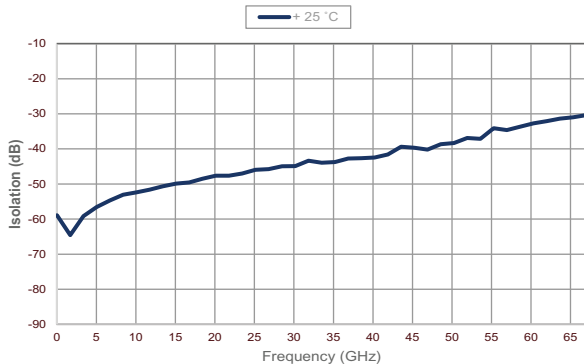

Figure 23 ■ Isolation (RF1-RF2, Active Port: RF1; or RF3 to RF4, Active Port: RF4)

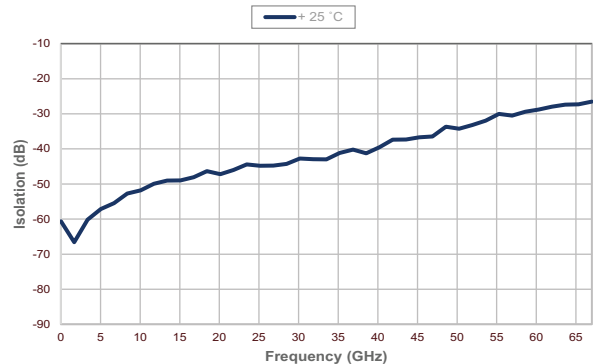

Figure 24 ■ Isolation (RFC-RF1, Active Port: RF2; or RFC RF4, Active Port: RF3)

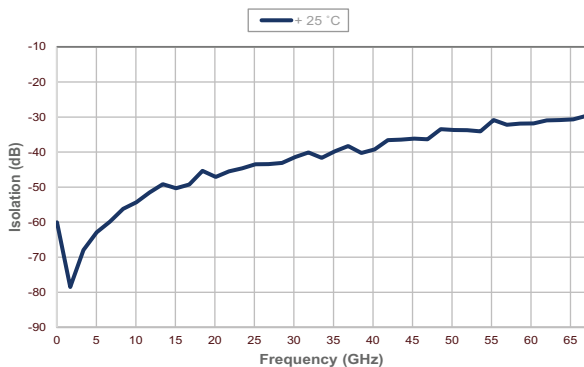
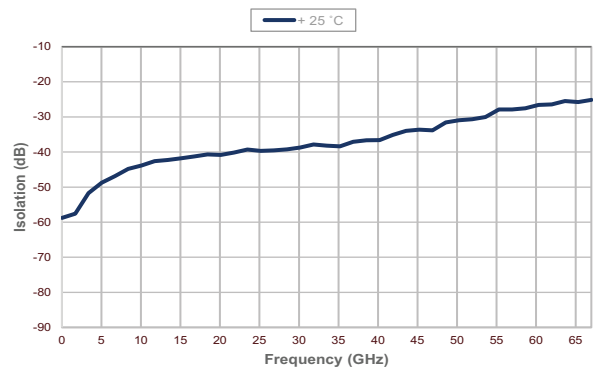

Figure 25 ■ Isolation (RF1-RF2, Active Port: RF2; or RF3 RF4, Active Port: RF3)



Evaluation Setup

Figure 26 shows the evaluation board setup. The PE42545 S-parameter data to 67 GHz (shown in Table 3 and Figure 4 through Figure 19) were taken using grounded co-planar waveguide (GCPW) transmission line structures in a PCB substrate and RF probes as shown in Figure 26.

The PE42545 second harmonic, input 1dB compression point, input IP2/3 measurements and switching time (in Table 3) were taken on a separate PCB using RF connectors.

Bypass capacitors are not required for the evaluation board setup.

Figure 26 ■ Probe Board for PE42545

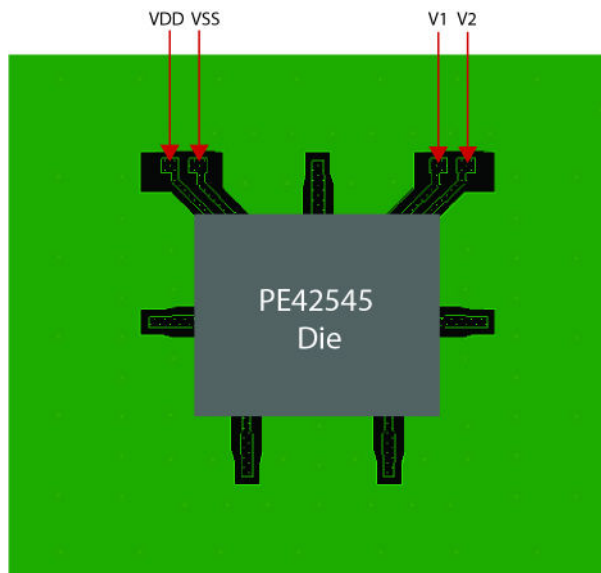

Bump Information

This section provides bump information for the PE42545. **Figure 27** shows the bump map of this device. All unlabeled bumps are GND. **Table 4** provides a description for each bump.

Figure 27 ■ Bump Configuration (Bumps Up)

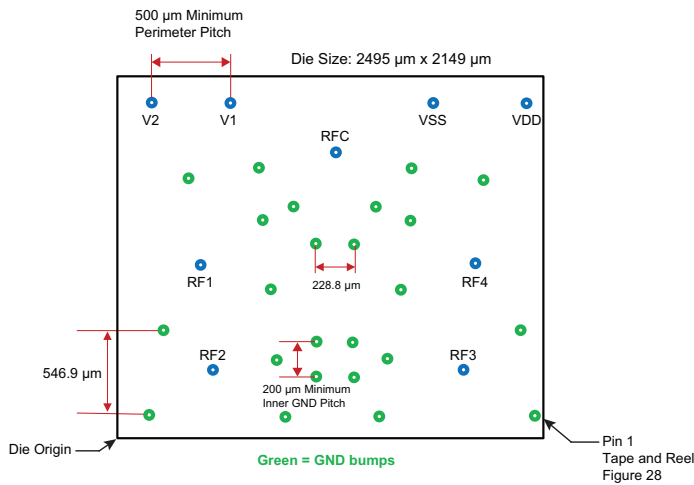

Table 4 ■ Bump Descriptions for PE42545

Bump Name	Description
GND	Ground
RF1	RF throw port 1
RF2	RF throw port 2
RF3	RF throw port 3
RF4	RF throw port 4
RFC	RF common port
V1	Control input 1
V2	Control input 2
VDD	Positive supply voltage
VSS	Negative supply voltage

Table 5 ■ Bump Coordinates for PE42545

Bump No.	Bump Name	Description	From Die Origin (μm) ^(*)	
			X	Y
1	V2	Control input 2	-1091.5	913.5
2	V1	Control input 1	-591.5	913.5
3	VSS	Negative supply voltage	591.5	913.5
4	VDD	Positive supply voltage	1091.5	913.5
5	GND	Ground	1128.5	-958.5
6	GND	Ground	303.5	-940.385
7	GND	Ground	-303.5	-940.385
8	GND	Ground	-1128.5	-958.5
9	GND	Ground	-1091.5	-411.595
10	GND	Ground	-858.615	469.71
11	RF1	RF throw port 1	-785.5	-26.62
12	RF2	RF throw port 2	-731.495	-648.49
13	GND	Ground	-428.5	216.5
14	GND	Ground	-445.87	530.87
15	GND	Ground	-353.5	-585.385
16	GND	Ground	-378.5	-180.65
17	GND	Ground	-239.42	306.17
18	GND	Ground	-114.42	-680.055
19	GND	Ground	-114.42	-480.055
20	GND	Ground	-114.42	91.17
21	RFC	RF common port	0	629
22	GND	Ground	114.42	-680.055
23	GND	Ground	114.42	-480.055
24	GND	Ground	114.42	91.17
25	GND	Ground	239.42	306.17
26	GND	Ground	353.5	-585.385
27	GND	Ground	378.5	-180.65
28	GND	Ground	428.5	216.5
29	GND	Ground	445.87	530.87

Table 5 ■ Bump Coordinates for PE42545 (Cont.)

Bump No.	Bump Name	Description	From Die Origin (μm) ^(*)	
			X	Y
30	RF3	RF throw port 3	731.495	-648.49
31	RF4	RF throw port 4	785.5	-26.62
32	GND	Ground	858.615	469.71
33	GND	Ground	1091.5	-411.595

Note: * All bump locations originate from the die center and refer to the center of the pin.

Control Logic

Table 6 provides the control logic truth table for the PE42545, where 0 = Low (0–0.8V) and 1 = High (1.2–3.3V).

Table 6 ■ Truth Table for PE42545

V1	V2	RF1	RF2	RF3	RF4
0	0	ON	Isolation	Isolation	Isolation
1	0	Isolation	ON	Isolation	Isolation
0	1	Isolation	Isolation	ON	Isolation
1	1	Isolation	Isolation	Isolation	ON

Die Mechanical Specifications

This section provides the die mechanical specifications for the PE42545.

Table 7 ▪ *Mechanical Specifications for PE42545*

Parameter	Min	Typ	Max	Unit	Test Condition
Die size, singulated (x, y)	2485 × 2139	2495 × 2149	2505 × 2159	μm	Including excess silicon, maximum tolerance = ±10 μm
Wafer thickness	180	200	220	μm	
Bump pitch	200			μm	
Bump height	59.5	70	80.5	μm	
Bump diameter		91		μm	
UBM diameter	71	75	79	μm	

Tape and Reel Specification

This section provides the tape and reel specifications for the PE42545.

Figure 28 ▪ Tape and Reel Specifications for PE42545

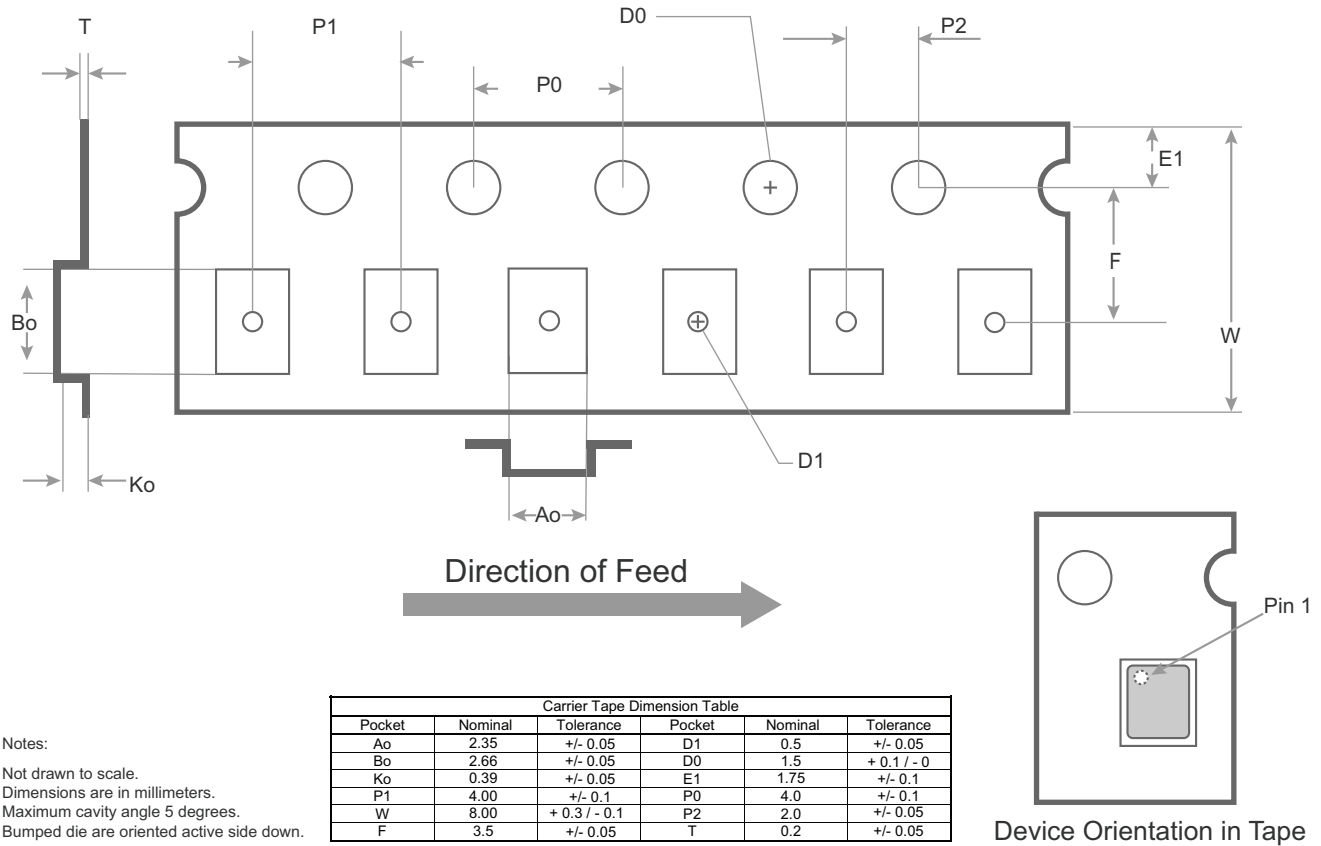

Ordering Information

Table 8 lists the available ordering codes for the PE42545 as well as available shipping methods.

Table 8 ■ Order Codes for PE42545

Order Codes	Description	Packaging	Shipping Method
PE42545A-Z	PE42545 SP4T RF switch	Die on tape and reel	3000 die/T&R
EK42545-01	PE42545 SP4T RF switch probe EVK	Evaluation Kit	1/Box
EK42545-88	PE42545 SP4T RF switch connectorized EVK	Evaluation Kit	1/Box

Document Categories

Advance Information

The product is in a formative or design stage. The datasheet contains design target specifications for product development. Specifications and features may change in any manner without notice.

Preliminary Specification

The datasheet contains preliminary data. Additional data may be added at a later date. pSemi reserves the right to change specifications at any time without notice in order to supply the best possible product.

Product Specification

The datasheet contains final data. In the event pSemi decides to change the specifications, pSemi will notify customers of the intended changes by issuing a CNF (Customer Notification Form).

Product Brief

This document contains a shortened version of the datasheet. For the full datasheet, contact sales@psemi.com.

Sales Contact

For additional information, contact Sales at sales@psemi.com.

Disclaimers

The information in this document is believed to be reliable. However, pSemi assumes no liability for the use of this information. Use shall be entirely at the user's own risk. No patent rights or licenses to any circuits described in this document are implied or granted to any third party. pSemi's products are not designed or intended for use in devices or systems intended for surgical implant, or in other applications intended to support or sustain life, or in any application in which the failure of the pSemi product could create a situation in which personal injury or death might occur. pSemi assumes no liability for damages, including consequential or incidental damages, arising out of the use of its products in such applications.

Patent Statement

pSemi products are protected under one or more of the following U.S. patents: patents.psemi.com

Copyright and Trademark

©2021-2022, pSemi Corporation. All rights reserved. The Peregrine Semiconductor name, Peregrine Semiconductor logo and UltraCMOS are registered trademarks and the pSemi name, pSemi logo, HaRP and DuNE are trademarks of pSemi Corporation in the U.S. and other countries.

X-ON Electronics

Largest Supplier of Electrical and Electronic Components

Click to view similar products for [RF Development Tools](#) category:

Click to view products by [pSemi](#) manufacturer:

Other Similar products are found below :

[F1950EVBI](#) [Si4689-QFN-EVB](#) [F2915EVBI](#) [SKY13414-485LF-EVB](#) [SKY13396-397LF-EVB](#) [SKY12212-478LF-EVB](#) [SKY85712-21EK1](#)
[SKY13698-694EK1](#) [4270-00](#) [4257-00](#) [5GMMWAVELPEVB-KIT](#) [EK42462-02](#) [EK42724-01](#) [EK42512-02](#) [TEL0146](#) [QPF4750EVB01](#)
[KG200ZABTB-KIT](#) [xG22-RB4415A](#) [EVALBAT1502ELTOBO1](#) [RFSWITCHCTRLBOARDTOBO1](#) [SKYR23001-11EK1](#) [xG22-EK2710A](#)
[471-043](#) [EK42722-02](#) [EK42545-01](#) [A5M36TG140-3400](#) [MAAM-011100-001SMB](#) [F1953EVBI](#) [F2976EVBI-50OHM](#) [LBWB1ZZYDZ-](#)
[DTEMP-SNIC-UART-A](#) [1497](#) [1958](#) [AS169-73LF-EVB](#) [AS179-92LF-EVB](#) [AS193-73LF-EVB](#) [EK42553-02](#) [EK42020-02](#) [MTUDK2-ST-](#)
[CELL](#) [SMP1330-085-EVB](#) [DVK-RM024-FCC](#) [SKY67101-396LF-EVB](#) [SKY13351-378LF-EVB](#) [SKY13286-359LF-EVB](#) [SKY13270-92LF-](#)
[EVB](#) [SKY12325-350LF-EVB](#) [SE5007T-EK1](#) [SE2576L-EK1](#) [SKY13322-375LF-EVB](#) [CLA4603-085-EVB](#) [SKY13298-360LF-EVB](#)