

# SPECIFICATIONS

| PARAMETERS  | VALUES       | UNITS |
|---|--------------|-------|
| RATED INPUT POWER                                   | 0.5          | W     |
| MAX INPUT POWER                                     | 1            | W     |
| IMPEDANCE   | 8 ± 15%      | OHM   |
| OUTPUT SPL @ 1W/0.5M<br>(AT 0.6, 0.8, 1.0, 1.2 kHz) | 82 ± 3       | dBA   |
| DISTORTION (MAX.)                                   | 5%           | -     |
| RESONANT FREQUENCY                                  | 900 ± 20%    | Hz    |
| FREQUENCY RANGE                                     | 900 ~ 20,000 | Hz    |
| HOUSING MATERIAL                                    | ABS          | -     |
| CONE MATERIAL                                       | CLOTH        | -     |
| MAGNET MATERIAL                                     | Nd-Fe-B      | -     |
| OPERATING TEMPERATURE                               | -40 ~ +85    | °C    |
| WEIGHT  | 5            | grams |

THIS DOCUMENT CONTAINS DATA PROPRIETARY TO PROJECTS UNLIMITED, INC. ANY USE OR REPRODUCTION, IN ANY FORM, WITHOUT PRIOR WRITTEN PERMISSION OF PROJECTS UNLIMITED, INC. IS PROHIBITED.  
©2003, Projects Unlimited Inc.

# REVISION HISTORY

| LTR | DESCRIPTION                              | DATE      | APPROVED |
|-----|--|-----------|----------|
| -   | RELEASED FROM ENGINEERING                | 6/6/2006  |          |
| A   | REVISED TO INVENTOR 3-D DRAWING TEMPLATE | 11/4/2008 | B.R.     |
| B   | REVISED SPECIFICATIONS AND CONE          | 8/19/2011 | C.W.     |

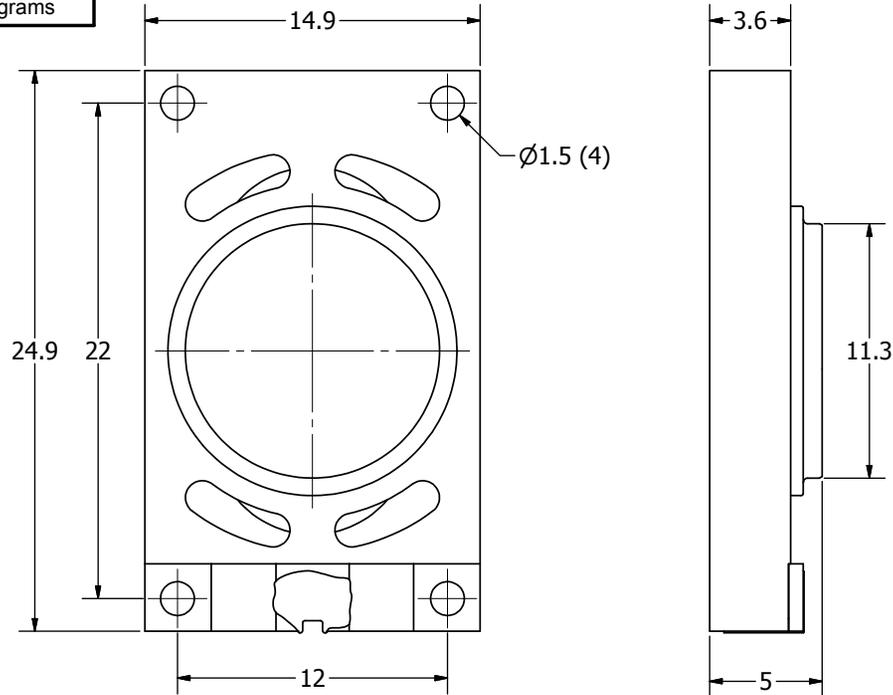

## NOTES:

1. ALL DIMENSIONS ARE IN MILLIMETERS.
2. SPECIFICATIONS SUBJECT TO CHANGE OR WITHDRAWAL WITHOUT NOTICE.
3. THIS PART IS RoHS 2002/95/EC COMPLIANT.

|  |  |             |                                 |            |          |             |          |            |
|--|--|-------------|---------------------------------|------------|----------|-------------|----------|------------|
| UNLESS OTHERWISE SPECIFIED:<br>DIMENSIONS ARE IN MILLIMETERS,<br>TOLERANCES ARE ±0.5 AND ANGLES ARE ±3°. | SIZE   | Designed by | Date                            | Checked by | Date     | Approved by | Date     | Drawn Date |
|  | A3   | J.D.        | 5/31/2006                       | E.P.       | 6/6/2006 | B.R.        | 6/6/2006 | 11/4/2008  |
| AS02508CO-2-R.idw  |  <b>pui audio</b><br>a projects unlimited company |             | <b>AS02508CO-2-R</b><br>Speaker |            |          | Edition     | Sheet    |            |
|  |  |             |                                 |            |          | -           | 1 / 1    |            |

## X-ON Electronics

Largest Supplier of Electrical and Electronic Components

*Click to view similar products for [Speakers & Transducers](#) category:*

*Click to view products by [PUI Audio](#) manufacturer:*

Other Similar products are found below :

[FC-30814-P127](#) [AS02832MR-2-R](#) [PB-1220PE](#) [PB-2015PQ](#) [900-00001](#) [AB2025B-LW50-R](#) [SWFK-31736-000](#) [PT-2065FW](#) [PT-4175W](#) [AT-2830-TW-LW35-R](#) [ED-30761-000](#) [CI-30120-A42](#) [SMT-0440-T-2-R](#) [PB-0927PQ](#) [BF-7083-000](#) [BF-9778-000](#) [SMS2020-08H4.5 LF](#) [BDT1717-08H6.5W56MLF](#) [02094](#) [02097](#) [GSPK1003PN-8R0.2W-L100](#) [GSPK151103TN-8R0.2W](#) [GSPK2014035PN-8R0.5W-L100](#) [FS5353DS0830-H19.3](#) [TE082703-8](#) [XMLP040BD21F](#) [AS03608MR-LW100-R](#) [24520](#) [SMT-0540-S-2-R](#) [1450069](#) [9091653](#) [9091661](#) [IPS-G6000-5](#) [9090231](#) [FS50MS0820-H9.7](#) [FS4014-4-2W](#) [PBM4-13.B31R.A115.0663](#) [PBM4-13.B33R.A115.0663](#) [PBM4-13.B35R.A115.0663](#) [A-10-6-BG360-HD1Z-GA-M4Z-ZW](#) [A-10-6-BG410-HD1Z-AA-AGZ-ZW](#) [A-10-6-BG410-HD1Z-AA-M4Z-ZW](#) [A-10-6-BG410-HD1Z-FC-AGZ-ZW](#) [A-10-6-BG410-HD1Z-GA-M4Z-ZW](#) [A-10-6-BG310-HD1Z-AA-AGZ-ZW](#) [A-10-6-BG310-HD1Z-AA-M4Z-ZW](#) [A-10-6-BG310-HD1Z-GA-M4Z-ZW](#) [A-10-6-BG316-HD1Z-AA-AGZ-ZW](#) [A-10-6-BG316-HD1Z-AA-M4Z-ZW](#) [A-10-6-BG325-HD1Z-AA-AGZ-ZW](#)