

# DATA SHEET

## INDUCTOR

Chip Bead

ABUP Series

RoHS compliant & Halogen Free



**Chip Bead ABUP Series** **Automotive  
AEC-Q200**

RoHS Compliant  
Halogen Free  
REACH Compliant



- Noise  
Suppression
- Shield
- Multilayer
- Ferrite
- High  
Current

**Part Numbering**

A	BUP	00	160808	600	Y	00
Grade	Series Name	Control Code	Dimensions Code (mm)	Impedance (Ω)	Tolerance	Internal Code
			160808 1.6x0.8x0.8	300 30	Y±25%	
			201209 2.0x1.25x0.9	800 80		
			321611 3.2x1.6x1.1	121 120		

This specification applies to Multilayer Chip ferrite Bead for Automotive Electronics based on AEC-Q200 except for Power train and Safety.

## Chip Bead ABUP Series

**Automotive**  
**AEC-Q200**

### ABUP00160808 Type

#### ■ Dimensions

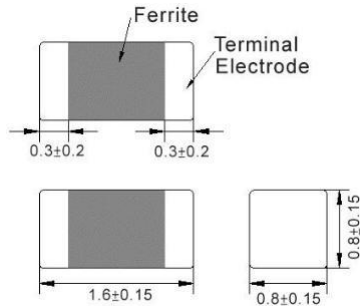

unit:mm

#### ■ Recommended Land Pattern

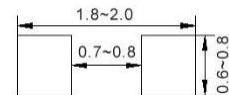

unit:mm

#### ■ Electrical Characteristics

Part No.	Impedance (Ω)	Test Freq.	RDC (Ω)Max.	Rated Current (mA)Max.
ABUP00160808300Y00	30	100 MHz,200 mV	0.015	4500
ABUP00160808101Y00	100	100 MHz,200 mV	0.030	3000
ABUP00160808121Y00	120	100 MHz,200 mV	0.030	3000
ABUP00160808181Y00	180	100 MHz,200 mV	0.050	2000
ABUP00160808221Y00	220	100 MHz,200 mV	0.040	2500

**Note: When ordering, please specify tolerance code. Tolerance: Y=±25%**

- Operating temperature range - 40°C ~ 125°C
- Rate Current : Applied the current to coils, the temperature rise shall not be more than 30°C
- Measure Equipment:  
Z: HP4291A  
RDC: HP4338B or CHEN HWA 502

**Chip Bead ABUP Series** **Automotive AEC-Q200**

**ABUP00160808 Type**

**■ Characteristics Graph**

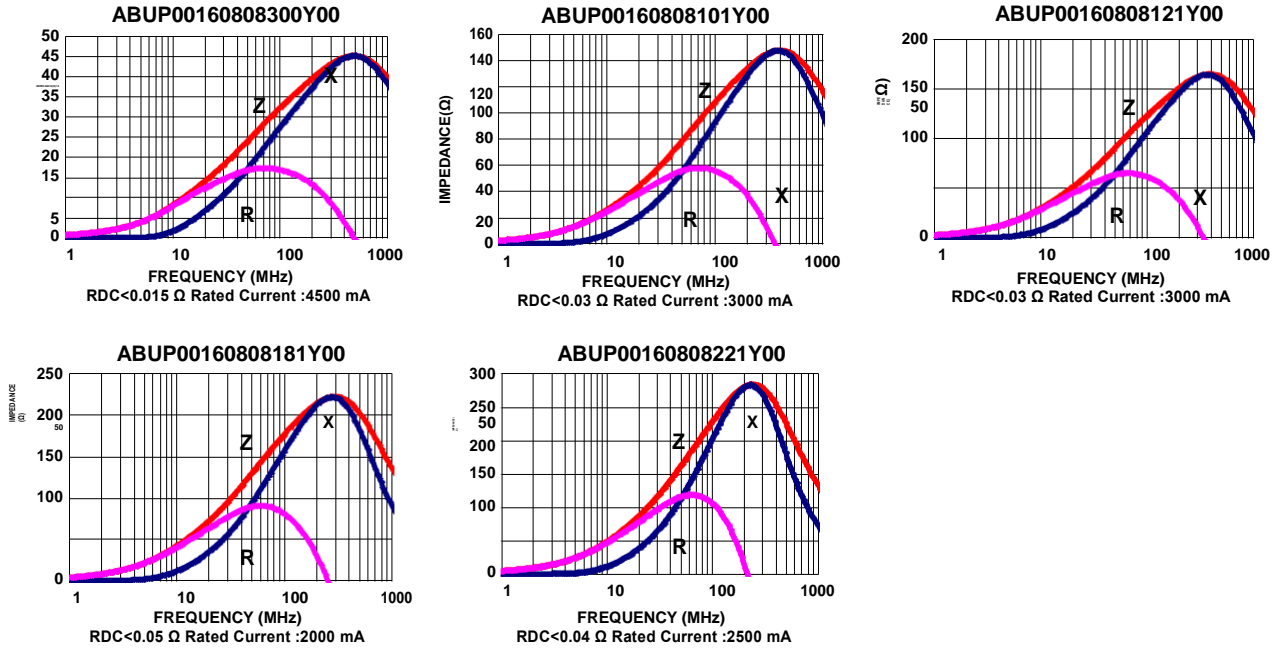

## Chip Bead ABUP Series

**Automotive**  
**AEC-Q200**

### ABUP0020109 Type

#### ■ Dimensions

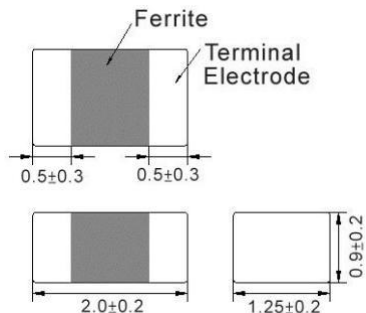

#### ■ Recommended Land Pattern

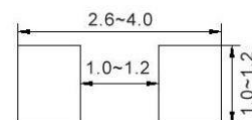

#### ■ Electrical Characteristics

Part No.	Impedance (Ω)	Test Freq.	RDC (Ω)Max.	Rated Current (mA)Max.
ABUP00201209220Y00	22	100 MHz,200 mV	0.012	6000
ABUP00201209300Y00	30	100 MHz,200 mV	0.012	6000
ABUP00201209500Y00	50	100 MHz,200 mV	0.015	6000
ABUP00201209600Y00	60	100 MHz,200 mV	0.018	6000
ABUP00201209800Y00	80	100 MHz,200 mV	0.020	6000
ABUP00201209101Y00	100	100 MHz,200 mV	0.020	5000
ABUP00201209121Y00	120	100 MHz,200 mV	0.020	5000
ABUP00201209201Y00	200	100 MHz,200 mV	0.040	3000
ABUP00201209221Y00	220	100 MHz,200 mV	0.040	3000
ABUP00201209301Y00	300	100 MHz,200 mV	0.050	3000
ABUP00201209331Y00	330	100 MHz,200 mV	0.050	3000

**Note: When ordering, please specify tolerance code. Tolerance: Y=±25%**

- Operating temperature range - 40°C ~ 125°C
- Rate Current : Applied the current to coils, the temperature rise shall not be more than 30°C
- Measure Equipment:  
Z: HP4291A  
RDC: HP4338B or CHEN HWA 502

**Chip Bead ABUP Series** **Automotive AEC-Q200**

**ABUP00201209 Type**

**Characteristics Graph**

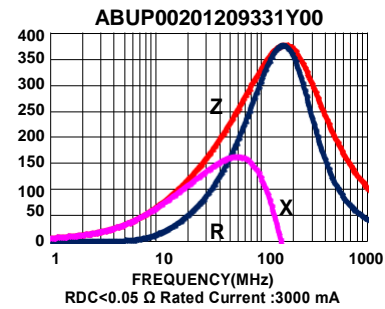
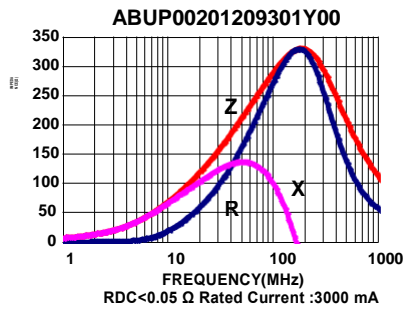
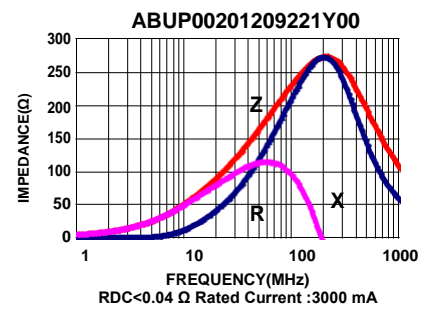
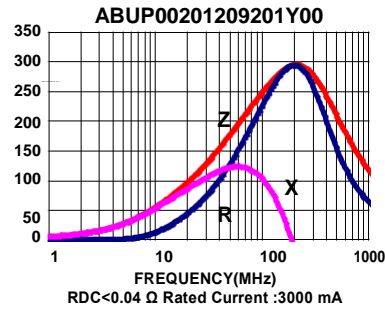
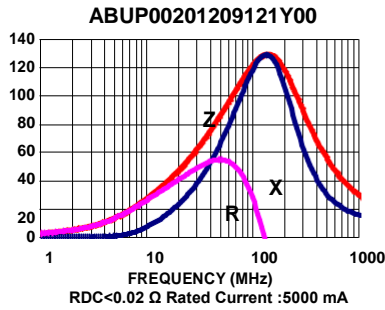
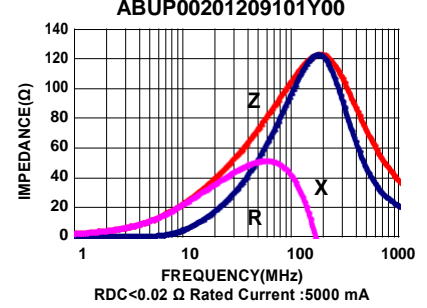
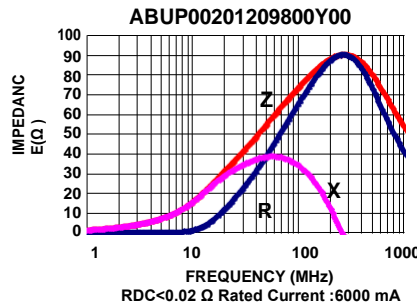
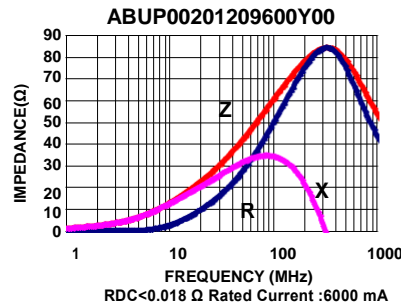
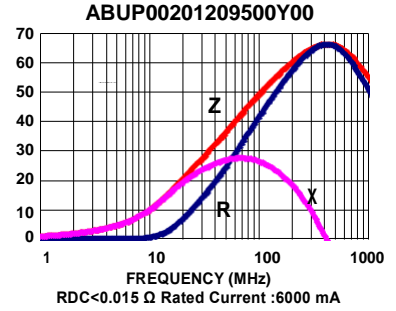
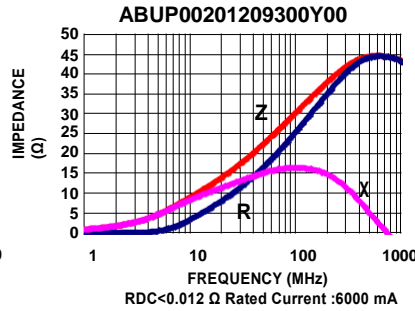
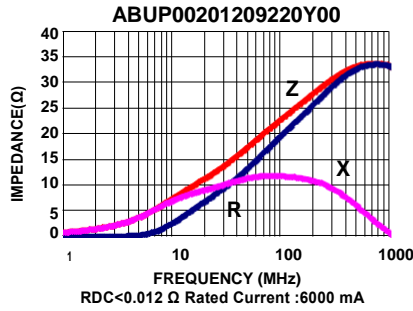

**Chip Bead ABUP Series**

**Automotive  
AEC-Q200**

**ABUP00321611 Type**

**■ Dimensions**

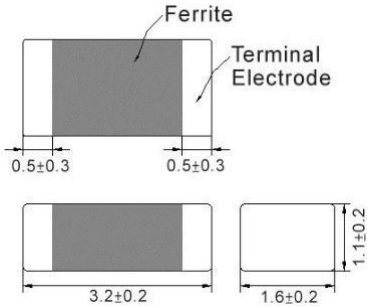

unit:mm

**■ Recommended Land Pattern**

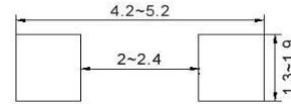

unit:mm

**■ Electrical Characteristics**

Part No.	Impedance (Ω)	Test Freq.	RDC (Ω)Max.	Rated Current (mA)Max.
ABUP00321611300Y00	30	100 MHz,200 mV	0.012	6000
ABUP00321611600Y00	60	100 MHz,200 mV	0.012	6000
ABUP00321611800Y00	80	100 MHz,200 mV	0.012	6000
ABUP00321611101Y00	100	100 MHz,200 mV	0.012	6000
ABUP00321611121Y00	120	100 MHz,200 mV	0.012	6000
ABUP00321611151Y00	150	100 MHz,200 mV	0.020	4500
ABUP00321611181Y00	180	100 MHz,200 mV	0.020	4500
ABUP00321611221Y00	220	100 MHz,200 mV	0.020	4500

**Note: When ordering, please specify tolerance code. Tolerance: Y=±25%**

1. Operating temperature range - 40°C ~ 125°C
2. Rate Current : Applied the current to coils, the temperature rise shall not be more than 30°C
3. Measure Equipment:  
Z: HP4291A  
RDC: HP4338B or CHEN HWA 502

**Chip Bead ABUP Series**

**Automotive  
AEC-Q200**

**ABUP00321611 Type**

**Characteristics Graph**

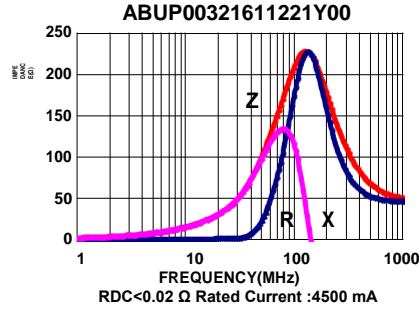
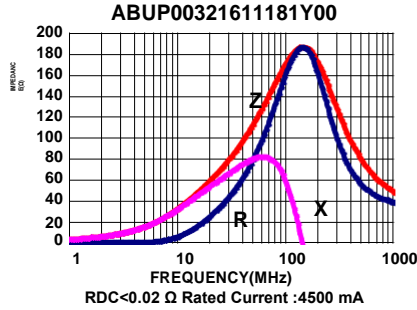
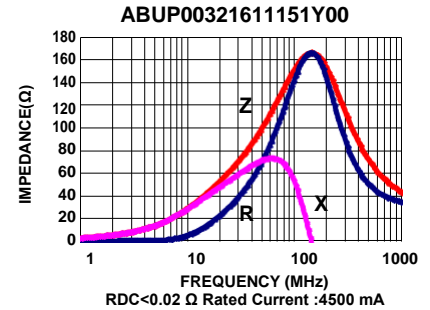
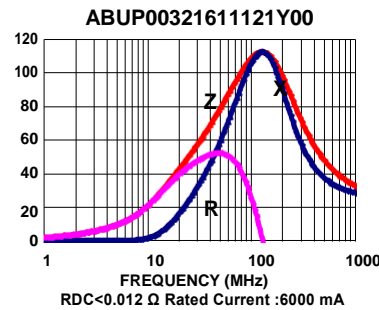
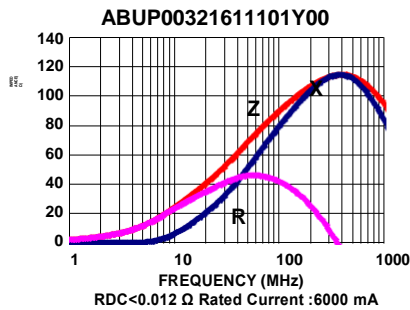
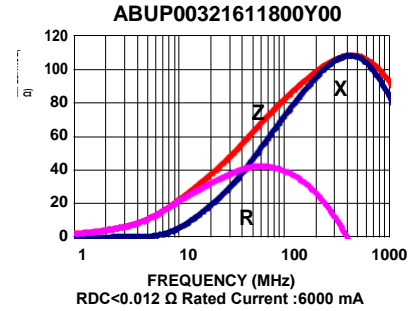
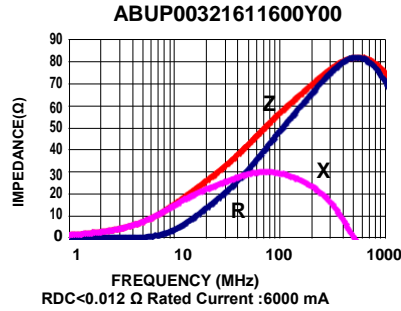
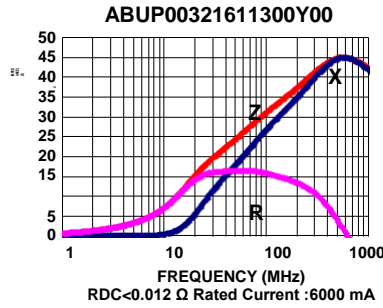



**Chip Bead ABUP Series** **Automotive  
AEC-Q200**

**■ Packaging**

**Tape Dimensions**

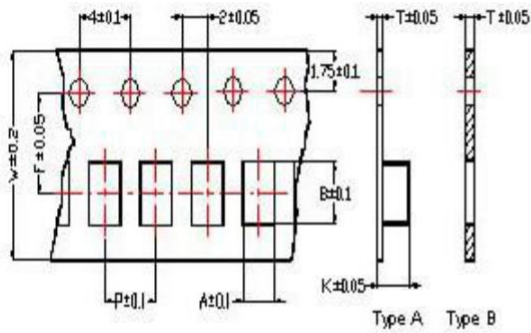

**Tape Material**

Carrier Tape: Polycarbonate (Tape A)  
Carrier Tape: Paper (Tape B)  
Cover Tape: Polystyrene

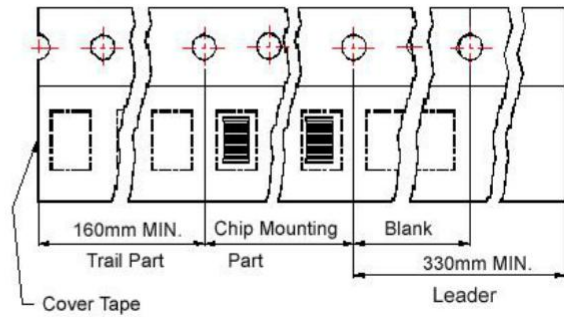

**Reel Dimensions**

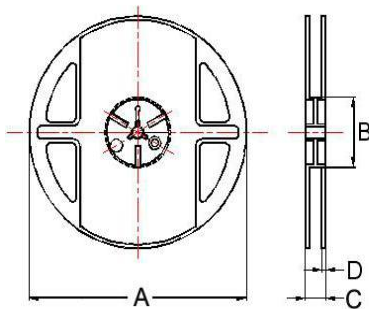

**Dimensions in mm**

TYPE	Tape Dimensions								Reel Dimensions				Quantity
	A	B	T	W	P	F	K	Tape	A	B	C	D	PCS / Reel
ABUP00160808	1.05	1.85	0.95	8	4	3.5	-	B	178	60	12	2	4000
ABUP00201209	1.50	2.30	0.97	8	4	3.5	-	B	178	60	12	2	4000
ABUP00321611	1.88	3.50	0.22	8	4	3.5	1.27	A	178	60	12	2	3000

## X-ON Electronics

Largest Supplier of Electrical and Electronic Components

*Click to view similar products for [Ferrite Beads](#) category:*

*Click to view products by [Pulse manufacturer](#):*

Other Similar products are found below :

[CZB1EGTTP700P](#) [CZB1JGTTD152P](#) [CZB2AFTTD800P](#) [CZB2AGTTD121P](#) [PE-0402FB121ST](#) [AB 3X2X3SM](#) [DER0705-2.2](#)  
[NCB0603R301TR050F](#) [NCB0805A320TR050F](#) [NCB-H1206B680TR300F](#) [CZB1JGTTD221P](#) [CZB1JGTTD600P](#) [CZB2AGTTD301P](#)  
[CZB2BFTTE301P](#) [CZB2BFTTE601P](#) [4221R-1](#) [EMI0805R-600](#) [SBY100505T-100Y-N](#) [NCB-GH0402D121TR060F](#) [NCB0402P301TR005F](#)  
[NCB0603R152TR030F](#) [NCB0805A121TR050F](#) [NCB0805A301TR070F](#) [NCB3312K900TR500F](#) [NCB-H0805A221TR300F](#)  
[NCB0402P221TR030F](#) [NCB0805A102TR040F](#) [NCB1806E151TR020F](#) [NCB-H0402P100TR200F](#) [NCB-H0603R121TR300F](#) [NCB-](#)  
[H0805A220TR600F](#) [NCB-H0805A390TR400F](#) [NCB-H1206B601TR200F](#) [CZB1JGTTD202P](#) [CBH160808W221T](#) [WLBD1005HCU330TL](#)  
[WLBD2012HCU121TH](#) [WLBD2012HCU221TH](#) [WQBD1608HCU121TH](#) [WLBD1608K2U252TB](#) [VLU0810-102KBC12](#)  
[WLBD1608K2U800TP](#) [BMB2A0080AN4](#) [SZ1608F470TF](#) [FBSHC0805-331-302R](#) [HFJ100505T-601Y-N](#) [HFY100505T-221Y-N](#)  
[PBY201209T-110Y-N](#) [SBY060303T-121Y-N](#) [SBY100505T-750Y-N](#)