

NOTES:

1. ROHS COMPLIANT
2. HEADER: PHENOLIC WITH FLAMMABILITY RATING UL 94V-0 OR BETTER.
3. STORAGE TEMPERATURE: -20°C TO +125°C
4. COMPLIANCE TO J-STD:
 - A. J-STD-002: SOLDERABILITY AT 245°C REFLOW PROFILE
 - B. J-STD-020: LEVEL 1, NO MOISTURE SENSITIVE
 - C. J-STD-075: R7, 245°C MAXIMUM THROUGH REFLOW SOLDER
5. TO ORDER TAPE & REEL PACKAGING ADD A "T" SUFFIX TO THE PART NUMBER(i.e E2023FNL BECOMES E2023FNLT).

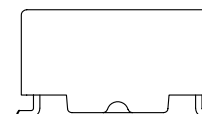
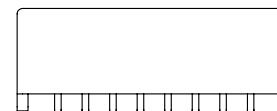

FINAL OUTLINE

© Copyright, 2014. Pulse Electronics Corp. All rights reserved. Pulse confidential & proprietary. (06/11/14)

PRODUCT DESCRIPTION	TLA DRAWING	PS DRAWING	SHEET	PART NO.	DATASHEET REV.
MDL,SIN,10D,1:2.5,SM,TU	E2023FNL-11	PS-2753.001-A	1 OF 3	E2023FNL	A

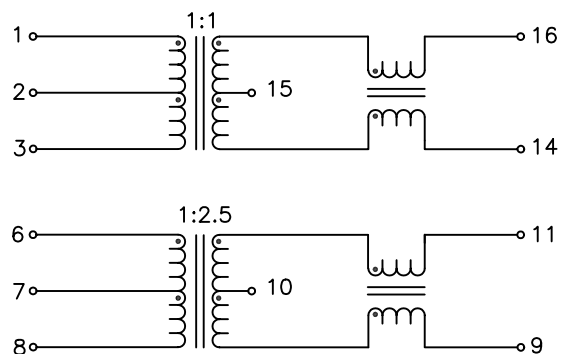

SCHEMATIC – PINS 4, 5, 12 AND 13 NOT CONNECTED

ELECTRICAL CHARACTERISTICS AT +25°C UNLESS OTHER SPECIFIED

PARAMETER	SPECIFICATIONS	
OPERATING TEMPERATURE	0°C – 70°C	
URNS RATIO	(1-3):(16-14) = 1CT : 1CT ±3% (6-8):(11-9) = 1CT : 2.5CT ±3%	
POLARITY	PER SCHEMATIC	
INDUCTANCE (OCL)	1-3 = 200 uH MIN AT 100 KHZ, 20 mVRMS 6-8 = 35 uH MIN AT 100 KHZ, 20 mVRMS	
LEAKAGE INDUCTANCE	(1-2) = 0.4 uH MAX WITH 14-16 SHORTED (6-7) = 0.25 uH MAX WITH 9-11 SHORTED (100 KHz, 20 mV)	
DC RESISTANCE	(1-2) = (2-3) = (6-7) = (7-8) = 0.6 OHM MAX (10-11) = (9-10) = (15-16) = (14-15) = 1.0 OHM MAX	
CWW	15 pF MAX AT 100 KHz, 1 VRMS	
COMMON MODE REJECTION	1-30 MHz	40-100 MHz
	-50 dB MIN	-40 dB MIN
BETWEEN CHANNEL ISOLATION	1500 VAC MIN @ 60 SECONDS	

© Copyright, 2014. Pulse Electronics Corp. All rights reserved. Pulse confidential & proprietary. (06/11/14)

PRODUCT DESCRIPTION	TLA DRAWING	PS DRAWING	SHEET	PART NO.	DATASHEET REV.
MDL,SIN,10D,1:2.5,SM,TU	E2023FNL-11	PS-2753.001-A	2 OF 3	E2023FNL	A

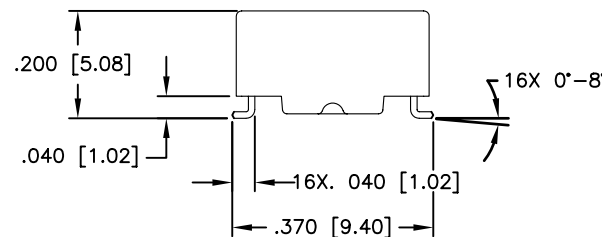
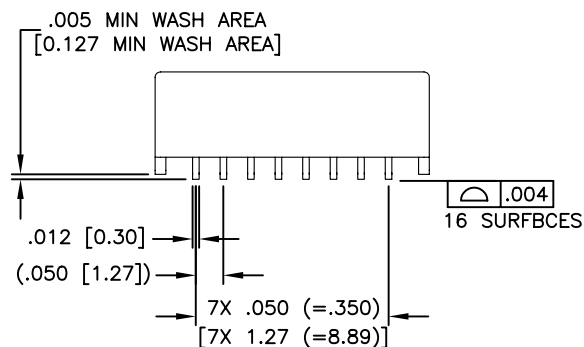
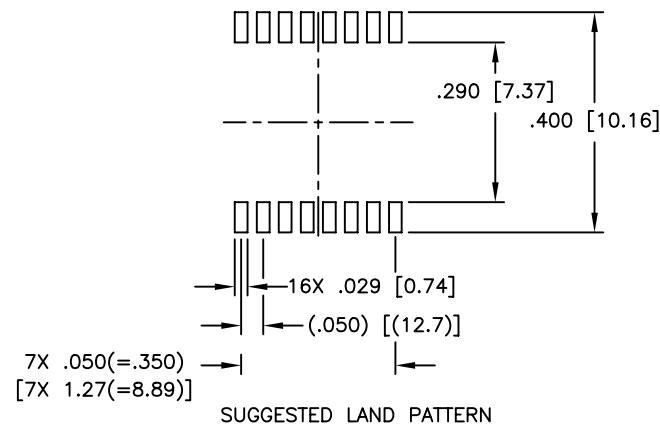
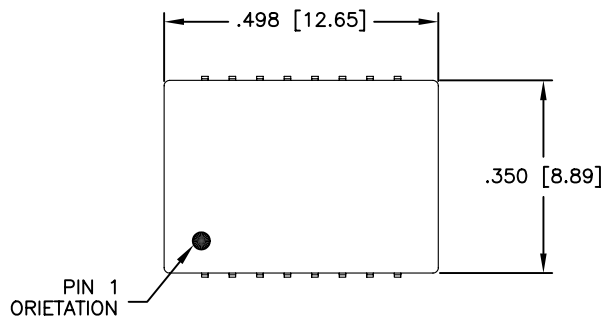

DIMENSIONS ARE IN INCHES [MILLIMETERS] WITH THE FOLLOWING TOLERANCES: [MILLIMETERS] ARE FOR REFERENCE ONLY.
 .XX= ±.01 [±0.25]
 .XXX= ±.005 [±0.13]

© Copyright, 2014. Pulse Electronics Corp. All rights reserved. Pulse confidential & proprietary. (06/11/14)

PRODUCT DESCRIPTION	TLA DRAWING	PS DRAWING	SHEET	PART NO.	DATASHEET REV.
MDL,SIN,10D,1:2.5,SM,TU	E2023FNL-11	PS-2753.001-A	3 OF 3	E2023FNL	A

X-ON Electronics

Largest Supplier of Electrical and Electronic Components

Click to view similar products for [Audio Transformers](#) / [Signal Transformers](#) category:

Click to view products by [Pulse manufacturer](#):

Other Similar products are found below :

[CX2041NLT](#) [MGPWT-00449-P](#) [PE-64961](#) [H1302FNLT](#) [H5008FNL](#) [H5012FNL](#) [H5020FNLT](#) [H5077NLT](#) [H5079NLT](#) [H5084FNLT](#)
[B78476A9558A003](#) [1812WBT2-4](#) [1879479-1](#) [HX2260FNL](#) [HX5014FNL](#) [EX2024FNL](#) [FL1066](#) [T1137NLT](#) [T3012NL](#) [PE-65812FNL](#) [PE-65848FNLT](#) [H1174FNL](#) [H1302FNL](#) [H5015FNL](#) [H5019EFNL](#) [H5062FNLT](#) [CX2047LNL](#) [MGPWT-00059-P](#) [MGPWT-00266-P](#) [MGPWT-00278-P](#) [MGPWT-00431-P](#) [TTC-100](#) [TTC-143-H](#) [TTC-5032-1](#) [BX1194WNLT](#) [HX1234NLT](#) [HX5008FNLT](#) [HX5019FNL](#) [HX5084NL](#) [3-1879385-5](#) [TX1263NLT](#) [4-1879391-0](#) [T1142NL](#) [HX6101FNL](#) [HX5084FNL](#) [HX1148NL](#) [HX5020FNLT](#) [HX5014FNLT](#) [T1124NL](#)
[1879732-1](#)