

PulseJack® 2xN Gigabit PoE





U.S. Patent#7241181

Description:

10/100/1000Base-T RJ45 2xN PoE Integrated Connectors with Magnetics, with the addition of power feeding over signal pairs.



Features and Benefits:

-  RoHS peak wave solder temperature rating 260°C
-  Suitable for CAT 5 & 6 UTP cable or better
-  Power over Ethernet enabled-compatible to IEEE 802.3af standard
-  350µH minimum OCL with 8mA bias current
-  High performance for maximum EMI suppression

Electrical Specifications @ 25°C - Operating Temperature 0°C to +70°C

RoHS Compliant Part Number (Number of Ports)	LEDs (L/R)	Insertion TX/RX (dB TYP)	Return Loss (dB TYP) 100Ω (±15Ω)				Crosstalk (dB TYP)			Common Mode Rejection (dB TYP)		Hipot (Vdc MIN)
			1-125 MHz	1-40 MHz	60 MHz	100 MHz	1-10 MHz	30-60 MHz	60-100 MHz	1-10 MHz	10-150 MHz	
JOB-0364NL (2X4)	G-Y/G-Y	-0.8	-20	-17	-14	-40	-35	-30	-50	-40	2250	
JOB-0366NL (2X6)	G-Y/G-Y	-0.8	-20	-17	-14	-40	-35	-30	-50	-40	2250	
JOB-0368NL (2X8)	G-Y/G-Y	-0.8	-20	-17	-14	-40	-35	-30	-50	-40	2250	

Notes: 1. Bi-color LEDs: G-Y = green/yellow. Contact Pulse for LED options

RJ45 Durability Test Rating

Part Number	Mating Force (MAX)	Unmating Force (MAX)	Durability
JOB Series	5 lbs./2.268 kgs.	5 lbs./2.268 kgs.	750 Insertions

RJ45 Material Specification

Part Number	Shield		Contact			Housing		MSL Rating
	Material	Finish	Material	Plating Area	Solder Area	Material	Specification	
JOB Series	Brass	20-40µ inches thick nickel over brass	5 lbs./2.268 kgs.	50µ inches gold over 30-50µ inches nickel	75-300µ inches tin-lead over 50-100µ inches nickel	Thermoplastic	UL 94 V-0	1

Notes:

1. Connector dimensions comply with FCC dimension requirements.

PulseJack® 2xN Gigabit PoE

U.S. Patent#7241181

2X4 Mechanicals

JOB-0364NL

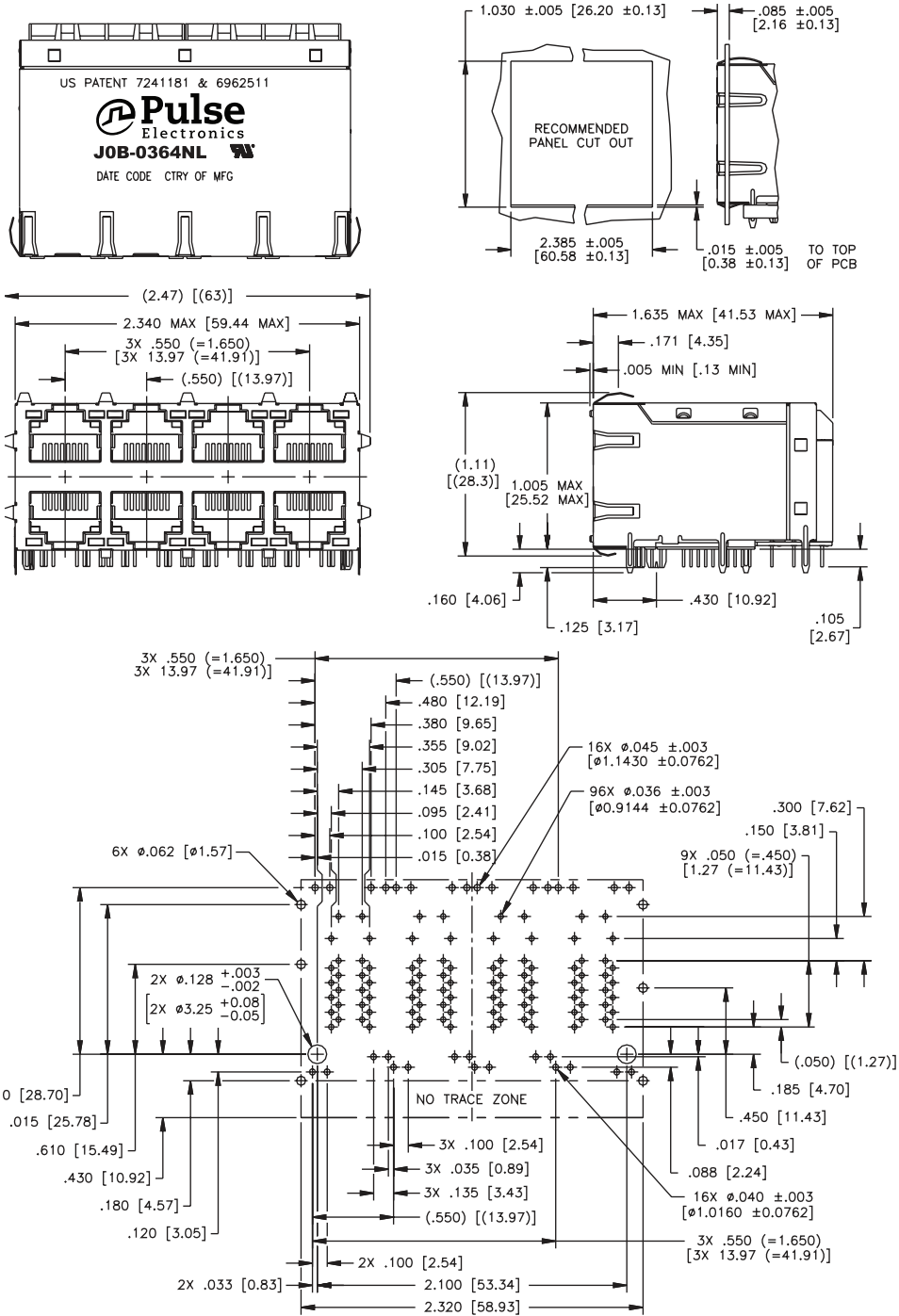

SUGGESTED PC BOARD LAYOUT VIEWED FROM COMPONENT SIDE
UNLESS OTHERWISE SPECIFIED DIMENSIONAL TOLERANCE IS ±.002

PulseJack® 2xN Gigabit PoE

U.S. Patent#7241181

2X6 Mechanicals

JOB-0366NL

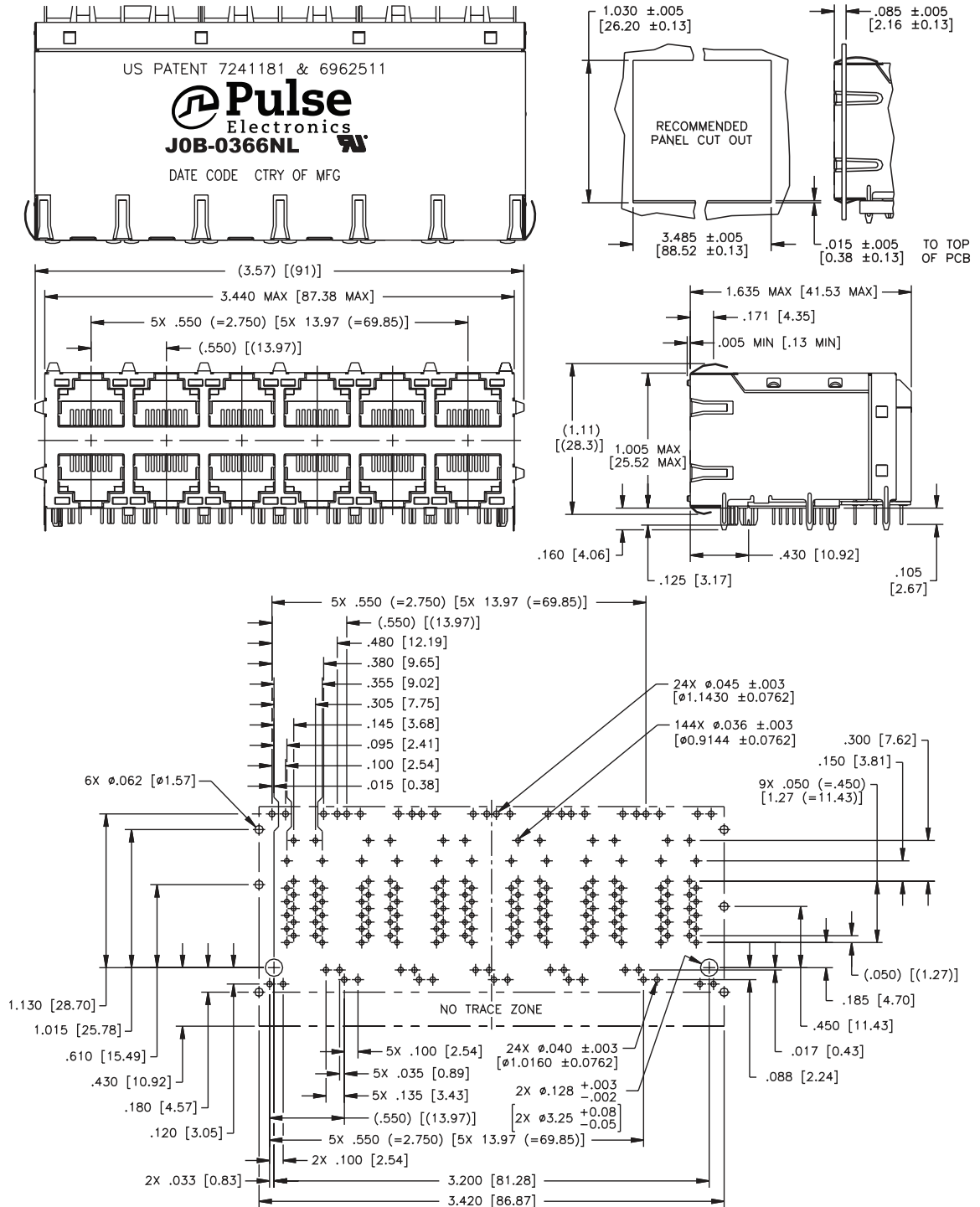

SUGGESTED PC BOARD LAYOUT VIEWED FROM COMPONENT SIDE
UNLESS OTHERWISE SPECIFIED DIMENSIONAL TOLERANCE IS ±.002

PulseJack® 2xN Gigabit PoE

U.S. Patent#7241181

2X8 Mechanicals

JOB-0368NL

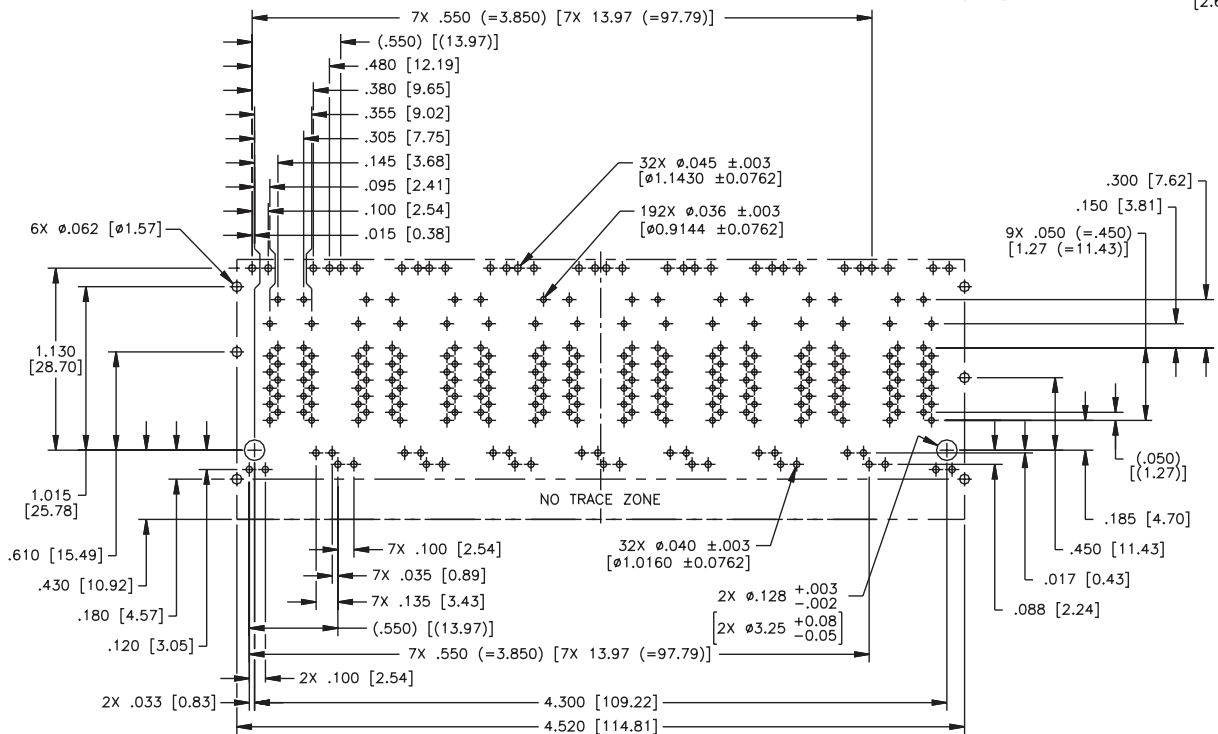
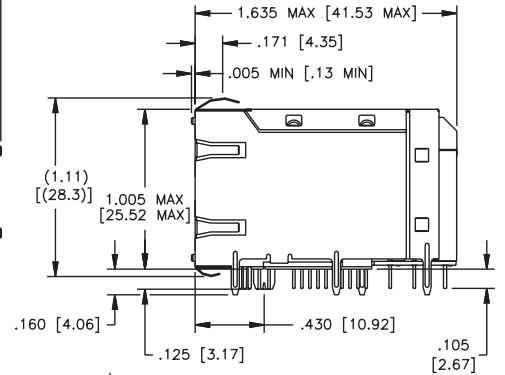
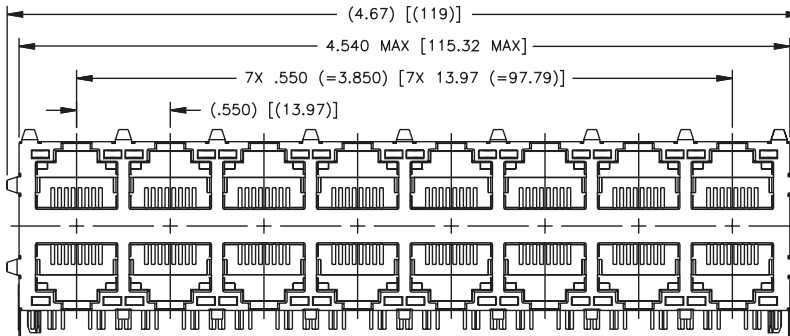
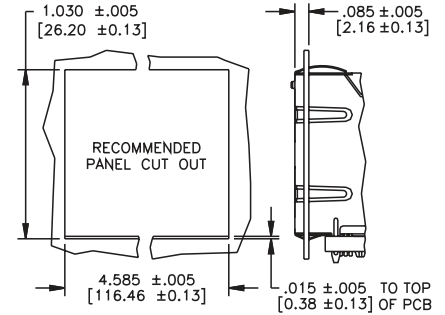
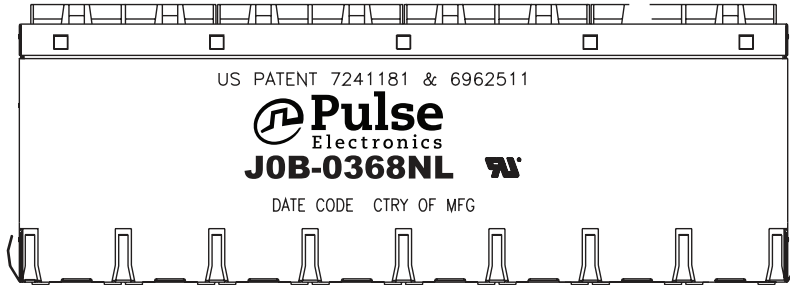

SUGGESTED PC BOARD LAYOUT VIEWED FROM COMPONENT SIDE
UNLESS OTHERWISE SPECIFIED DIMENSIONAL TOLERANCE IS ±.002

PulseJack® 2xN Gigabit PoE

U.S. Patent#7241181

Pin-Out Assignment

J0B-0364NL/66NL/68NL

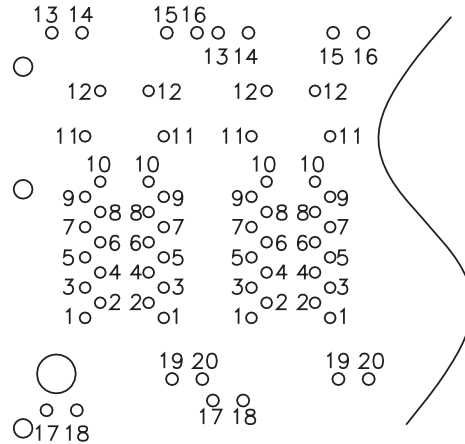

PIN ASSIGNMENT (COMPONENT SIDE VIEW)

NOTE: All parts use the same port identification system. J0B-0368NL (2x8) shown here.

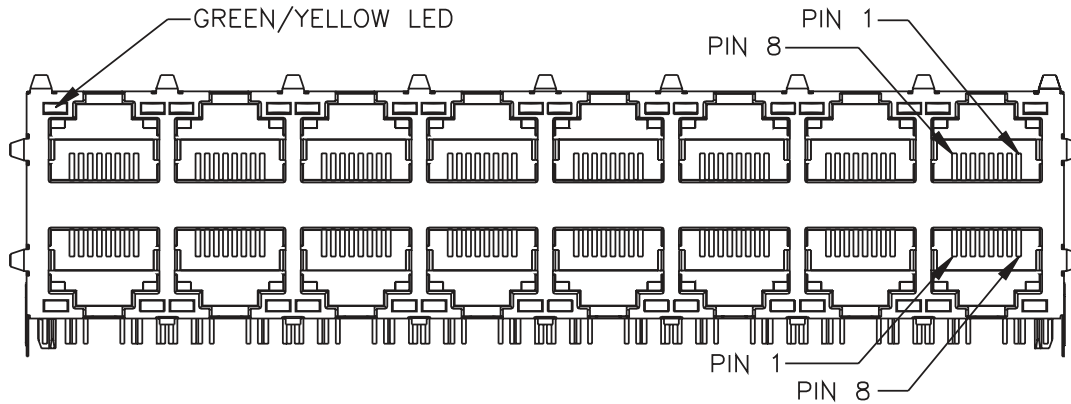
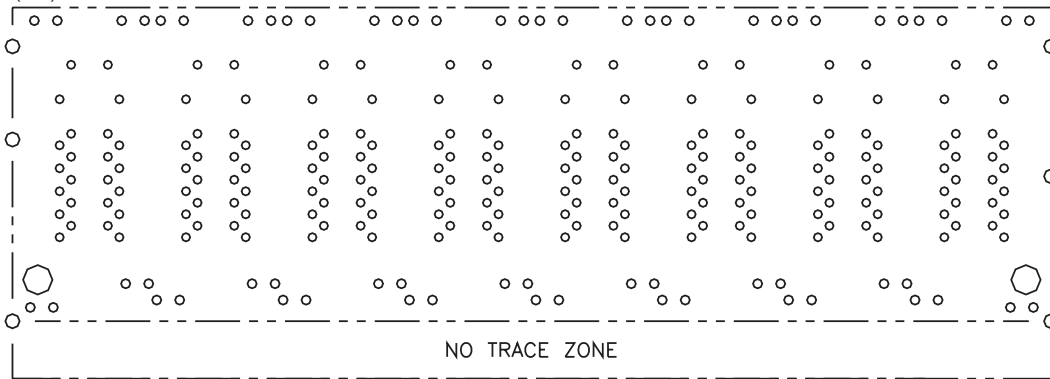

PulseJack® 2xN Gigabit PoE

U.S. Patent#7241181

Schematic

JOB-0364NL/66NL/68NL

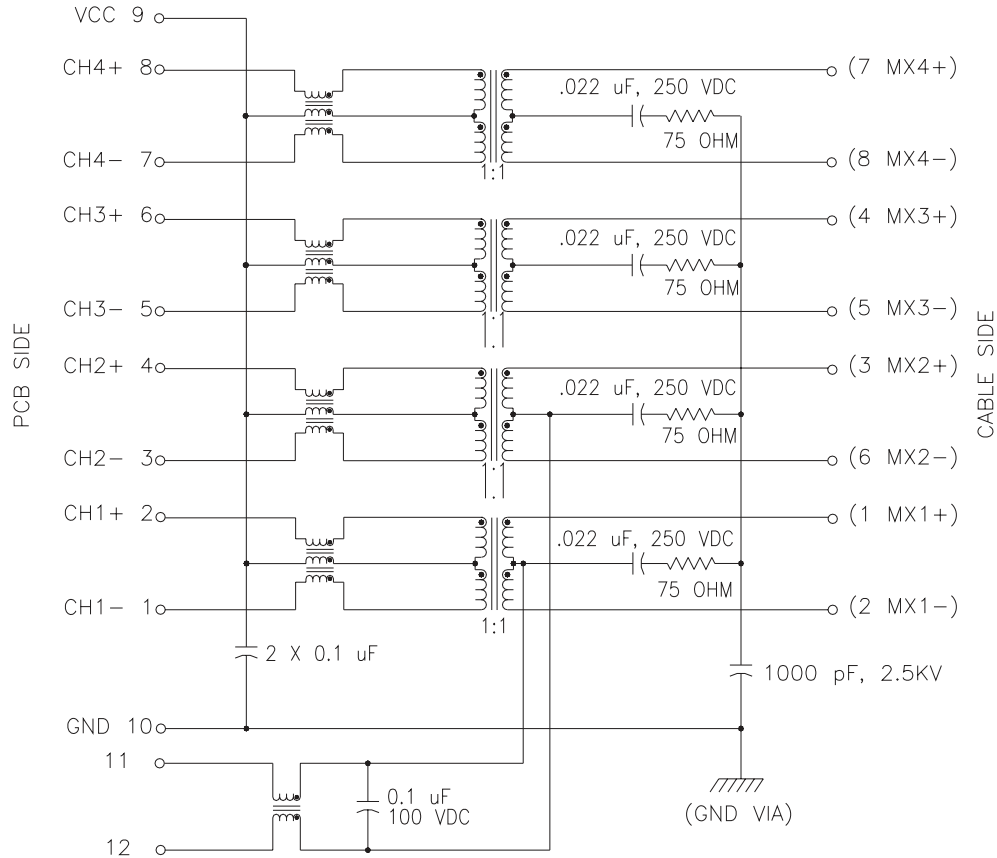

EMMITTED COLOR	GREEN	YELLOW
WAVELENGTH (nm)	570 nm	590 nm
BRIGHTNESS (mCD)	8.5 TYP. @ 20mA	6 TYP. @ 20 mA
VIEWING ANGLE	100°	100°
POWER DISSIPATION (Pd)	85 mW MAX	85 mW MAX
FORWARD VOLTAGE (Vf)	2.2 TO 2.8 V	2.15 TO 2.8 V
REVERSE VOLTAGE (Vr)	5.0 V MAX	5.0 V MAX

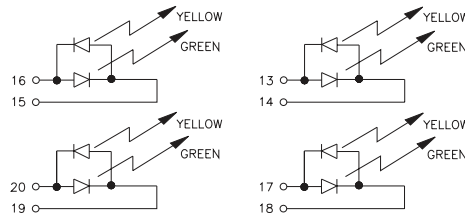

For More Information:

Americas - prodinfonetworkamericas@pulseelectronics.com | Europe - comms-Apps-Europe@pulseelectronics.com | Asia - prodinfonetworkapac@pulseelectronics.com

Performance warranty of products offered on this data sheet is limited to the parameters specified. Data is subject to change without notice. Other brand and product names mentioned herein may be trademarks or registered trademarks of their respective owners. © Copyright, 2019. Pulse Electronics, Inc. All rights reserved.

X-ON Electronics

Largest Supplier of Electrical and Electronic Components

Click to view similar products for [Modular Connectors / Ethernet Connectors](#) category:

Click to view products by [Pulse manufacturer](#):

Other Similar products are found below :

[8949-H88/06BLKA/SN](#) [74441-0010/BKN](#) [MP1010RX-1000](#) [MP44RX-1000](#) [PHJ-4P4C-1-V-4](#) [PHP-6P6C-5](#) [GAX-3-66](#) [GAX-8-62](#) [GDCX-PA-66-50](#) [GDCX-PN-64](#) [GDCX-PN-66](#) [GDCX-PN-66-50](#) [GDLX-A-66](#) [GDLX-N-66](#) [GDLX-S-66](#) [GDLX-S-88K](#) [GDTX-S-88-50](#) [GDX-PA-1010](#) [GLX-N-1010M-BLK](#) [GLX-S-88M-BLK](#) [GMX-N-1010](#) [GMX-S-1010](#) [GMX-S-66](#) [GMX-SMT4-N-88](#) [GPX-2-64](#) [GSGX-N-2-88](#) [GSGX-N-4-88](#) [GSX-NS2-88-3.05](#) [GSX-NS2-88-3.05-50](#) [GSX-NS-88-3.05-50](#) [PT-108A-8C-UL](#) [PT-J951-8C](#) [PTS-J531-8CS-50UL](#) [1-1775629-2](#) [A-2014-0-4](#) [GWLX-S-88-GR](#) [GWLX-S9-88-YG](#) [DC-1021-8-WH-6](#) [1300530003](#) [1324640-4](#) [RJ11FTVC2G](#) [RJ11FTVC2N](#) [RJFTVX2SA1G](#) [132764-001](#) [1413235](#) [MP88X-1000](#) [MPS88RX-5000](#) [E5288-S000K3-L](#) [E5908-15A242-L](#) [155302-001](#)