



NOTES: UNLESS OTHERWISE SPECIFIED

- THIS COMPONENT CONFORMS TO UL60950. UL FILE NO. IS: E216117.

	WARNING: THIS COMPONENT IS RECOGNIZED BY ONE OR MORE SAFETY AGENCIES SUCH AS UL, VDE, CSA AND/OR TUV. ALL ENGINEERING CHANGES MUST HAVE PRIOR APPROVAL BY THE DESIGN CENTER QUALITY DEPARTMENT FOR SAFETY AGENCY COMPLIANCE.	EDN APPROVAL: QA APPROVAL: DATE:

- | | |
|---|---|
|  | NOTICE: THIS IS A RoHS COMPLIANT COMPONENT/PRODUCT. ALL ENGINEERING CHANGES MUST HAVE PRIOR APPROVAL BY THE DESIGN CENTER. |
| | RoHS |

- PLASTIC HOUSING: THERMOPLASTIC MATERIAL WITH FLAMMABILITY RATING UL 94V-0 OR BETTER.
- CONTACT BASE MATERIAL: PHOSPHOR BRONZE.
- CONTACTS UNDERPLATE: 30-50 MICROINCHES DUCTILE NICKEL.
- CONTACTS PLATING: 30 MICROINCHES GOLD PLATING.
- SOLDER TAIL PLATING MATERIAL: 200-500 MICROINCHES 100% TIN, MATTE FINISH.
- METAL SHIELD: NICKEL PLATING ON COPPER ALLOY.

- JACK CAVITY CONFORMS TO FCC RULES AND REGULATIONS PART 68 SUBPART F.

- PCB PLATING: EG.
- SOLDERABILITY: CONFORMS TO ANSI/J-STD-002, IPC/EIA J-STD-003A.
- OPERATING TEMPERATURE: 0°C TO +70°C
- STORAGE TEMPERATURE: -20°C TO +125°C
- JEDEC MOISTURE: LEVEL 1.
- DIMENSIONS ARE IN INCHES [MILLIMETERS] WITH THE FOLLOWING TOLERANCES: [MILLIMETERS] ARE FOR REFERENCE ONLY.
 .XX= ±.02 [±0.5]
 .XXX= ±.010 [±0.25]

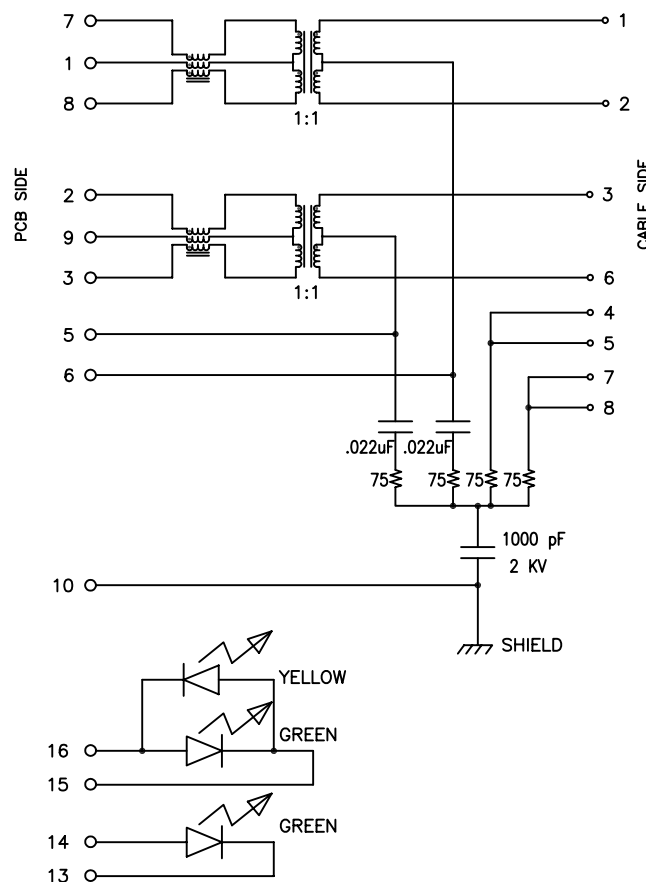

SCHMATIC

ELECTRICAL CHARACTERISTICS AT +25°C UNLESS OTHERWISE SPECIFIED (FOR REFERENCE ONLY. USED FOR CUSTOMER INFORMATION.)

PARAMETER	SPECIFICATION	
OPERATING TEMP	0°C-70°C	
URNS RATIO	1 : 1 ±2%	
POLARITY	PER SCHEMATIC	
INSERTION LOSS	100 KHz	1-125 MHz
	-1.2 dB MAX	-0.2-0.002*f ^{1.4} dB MAX
RETURN LOSS (Z OUT = 100 OHM ±15%)	.1-30 MHz	30-60 MHz
	-16 dB MIN	-10+20*LOG ₁₀ (f/60 MHz) dB MIN
INDUCTANCE (OCL) (MEDIA SIDE, 0°C-70°C)	350 uH MIN (MEASURED AT 100 KHz, 100 mVRMS AND WITH 8 mA DC BIAS)	
	1 MHz	10-100 MHz
CROSSTALK, ADJACENT CHANNELS	-50 dB MIN	-55+22*LOG ₁₀ (f/10) dB MIN
	2 MHz	30-200 MHz
COMMON MODE REJECTION RATIO	-50 dB MIN	-15+20*LOG ₁₀ (f/200) dB MIN
	.65 OHMS MAX	
DC RESISTANCE, 1/2 WINDING	±.065 OHMS MAX (CENTER TAP SYMMETRY)	
DC RESISTANCE IMBALANCE	1500 VRMS MIN @ 60 SECONDS	
INPUT - OUTPUT ISOLATION		

NOTE: f IS FREQUENCY IN MHz.

EMMITTED COLOR	GREEN	GREEN	YELLOW
WAVELENGTH (nm)	568 nM	568 nM	585 nM
BRIGHTNESS (mCD)	12 TYP. @ 20mA	8.5 TYP. @ 20 mA	6.0 TYP. @ 20 mA
VIEWING ANGLE	100°	100°	100°
POWER DISSIPATION (Pd)	68 mW MAX	100 mW MAX	100 mW MAX
DC FORWARD CURRENT	150 mA MAX	150 mA MAX	150 mA MAX
FORWARD VOLTAGE (Vf)	2.2 TO 2.7 VOLTS	2.2 TO 2.6 VOLTS	2.1 TO 2.6 VOLTS
REVERSE VOLTAGE (Vr)	5.0 V MAX	5.0 V MAX	5.0 V MAX

NOTE: PER VENDOR'S SPECIFICATIONS

BI-COLOR

© Copyright, 2010. Pulse Electronics Corp. All rights reserved. Drawing specifications subject to change without notice. (12/07/10)

PULSE CONFIDENTIAL & PROPRIETARY	PRODUCT DESCRIPTION	PS DRAWING	SHEET:	DWG. NO./ PART NO.	REV.
	CONN,RJ45,1X1,100P,1:1,TY	PS-2390.009-B	1	JK0-0125NL	M10

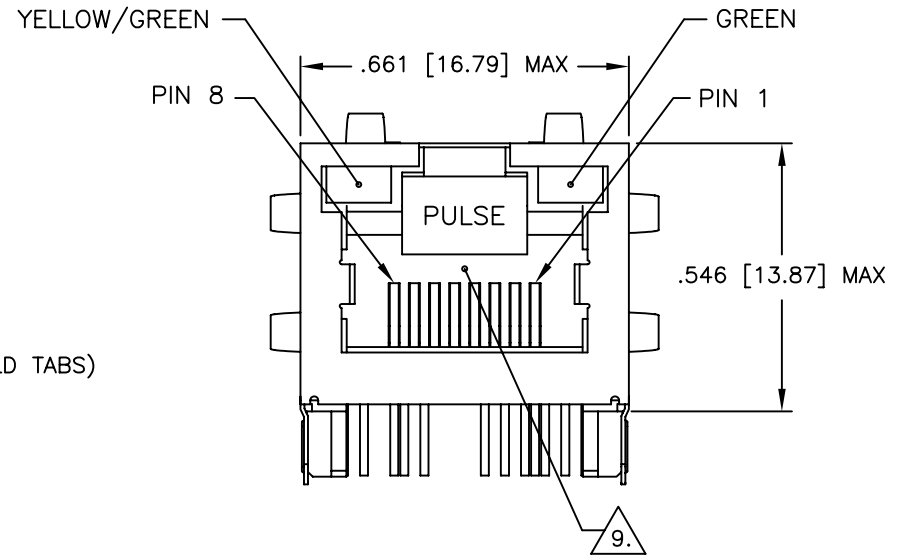
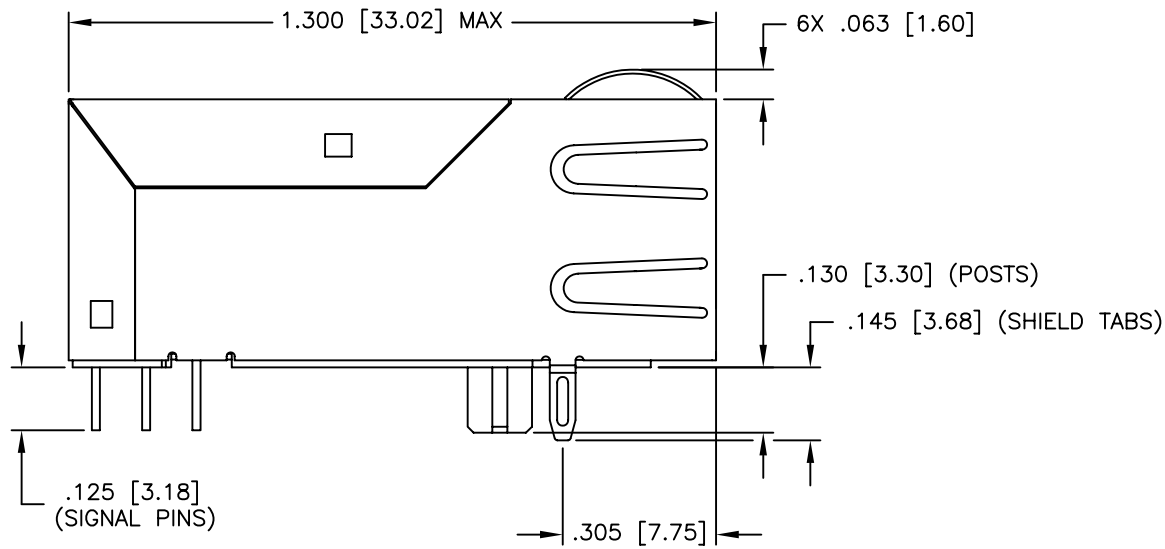
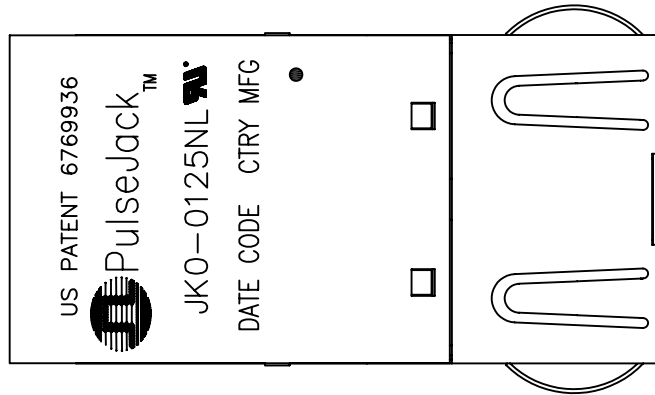

© Copyright, 2010. Pulse Electronics Corp. All rights reserved. Drawing specifications subject to change without notice. (12/07/10)

PULSE CONFIDENTIAL
&
PROPRIETARY

PRODUCT DESCRIPTION
CONN,RJ45,1X1,100P,1:1,TY

PS DRAWING
PS-2390.009-B

SHEET:
2

DWG. NO./ PART NO.
JK0-0125NL

REV.
M10

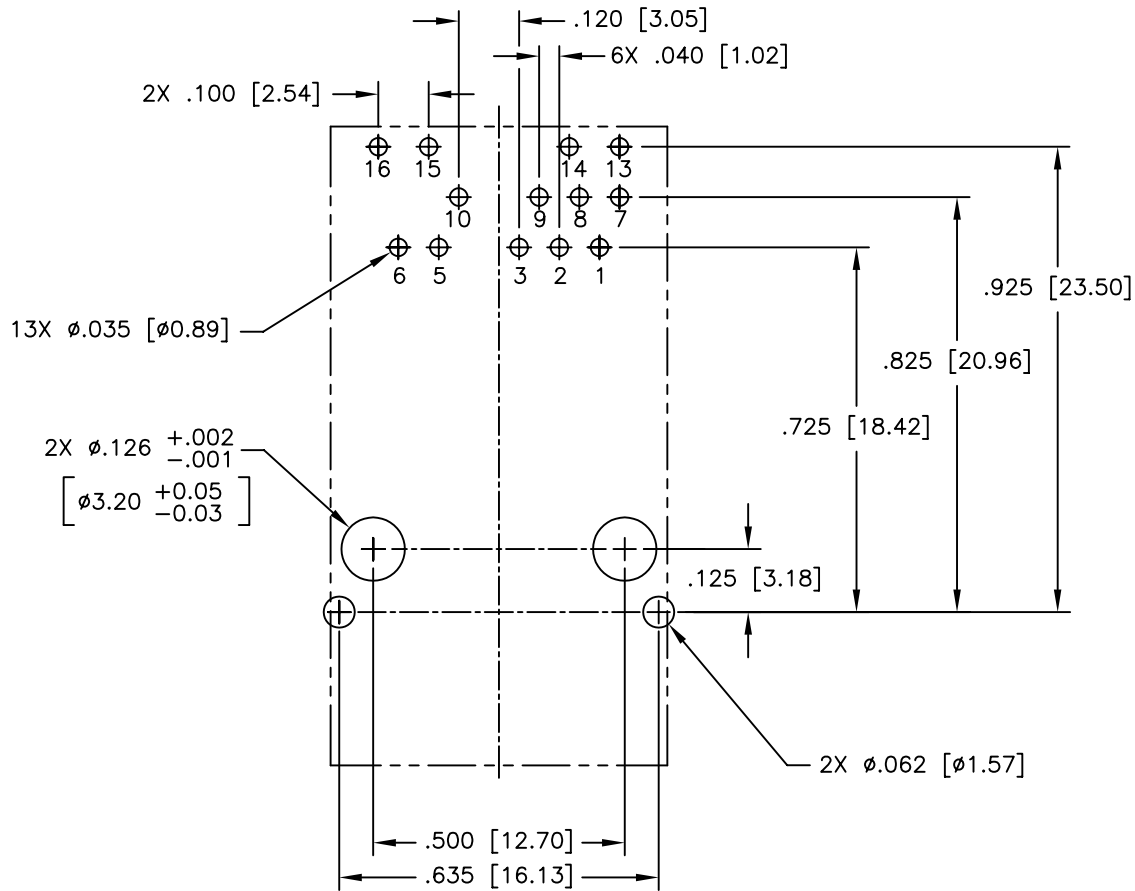

FRONT OF CONNECTOR
 SUGGESTED PCB LAYOUT
 (COMPONENT SIDE SHOWN)
 DIMENSIONAL TOLERANCE:
 .XXX \pm .003 [X.XX \pm 0.08]

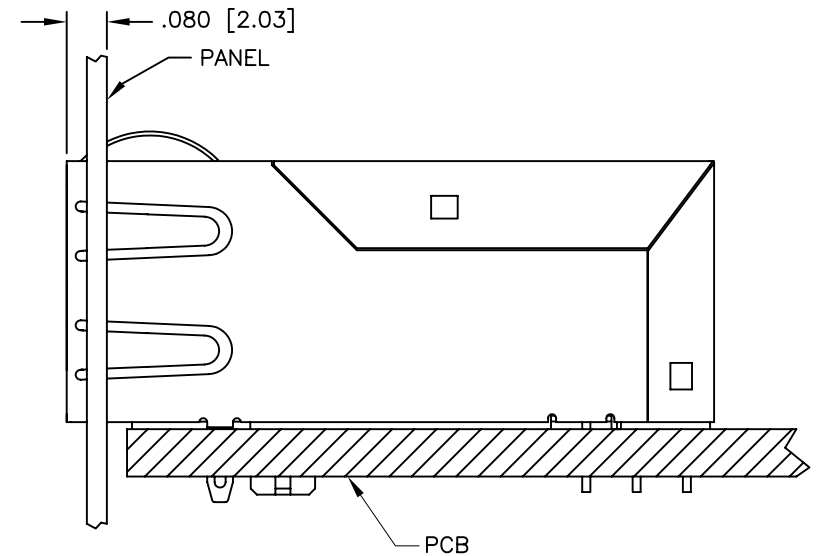
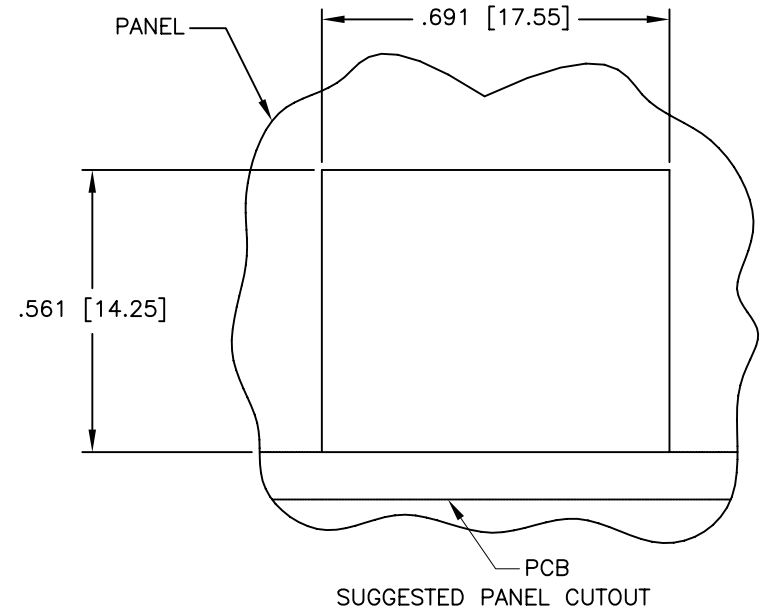

© Copyright, 2010. Pulse Electronics Corp. All rights reserved. Drawing specifications subject to change without notice. (12/07/10)

PULSE CONFIDENTIAL & PROPRIETARY	PRODUCT DESCRIPTION	PS DRAWING	SHEET:	DWG. NO./ PART NO.	REV.
		CONN,RJ45,1X1,100P,1:1,TY	PS-2390.009-B	3	JK0-0125NL

X-ON Electronics

Largest Supplier of Electrical and Electronic Components

Click to view similar products for [Modular Connectors / Ethernet Connectors](#) category:

Click to view products by [Pulse](#) manufacturer:

Other Similar products are found below :

[8949-H88/06BLKA/SN](#) [74441-0010/BKN](#) [MP1010RX-1000](#) [MP44RX-1000](#) [PHJ-4P4C-1-V-4](#) [PHP-6P6C-5](#) [GAX-3-66](#) [GAX-8-62](#) [GDCX-PA-66-50](#) [GDCX-PN-64](#) [GDCX-PN-66](#) [GDCX-PN-66-50](#) [GDLX-A-66](#) [GDLX-N-66](#) [GDLX-S-66](#) [GDLX-S-88K](#) [GDLX-SMT-S-88](#) [GDTX-S-88-50](#) [GDX-PA-1010](#) [GLX-N-1010M-BLK](#) [GLX-S-88M-BLK](#) [GMX-N-1010](#) [GMX-S-1010](#) [GMX-S-66](#) [GMX-SMT4-N-88](#) [GPX-2-64](#) [GSGX-N-2-88](#) [GSGX-N-4-88](#) [GSX-NS2-88-3.05](#) [GSX-NS2-88-3.05-50](#) [GSX-NS-88-3.05-50](#) [PT-108A-8C-UL](#) [PT-J951-8C](#) [PTS-J531-8CS-50UL](#) [1-1775629-2](#) [A-2014-0-4](#) [GWLX-S-88-GR](#) [GWLX-S9-88-YG](#) [DC-1021-8-WH-6](#) [1300530003](#) [1324640-4](#) [RJ11FTVC2G](#) [RJ11FTVC2N](#) [RJFTVX2SA1G](#) [132764-001](#) [1413235](#) [MP88X-1000](#) [MPS88RX-5000](#) [E5288-S000K3-L](#) [E5908-15A242-L](#)