

SMT POWER INDUCTORS

Shielded Drum Core - PL91XX Series

Ruggedized

PulseR
Ruggedized Solutions



- R Height: 0.248 inches (6.3mm) Max
- R Footprint: 0.413 inches x 0.413 inches (10.5mm x 10.5mm) Max
- R Inductance Range: 0.96 μ H to 879 μ H
- R Current Rating: up to 10.5A
- R Moisture Sensitivity Level: 1

Electrical Specifications @25°C — Operating temperature: - 55°C to + 130°C

Part Numbers	Inductance @I _{rated} (μ H TYP)	I _{rated} ² (A)	DCR (m Ω)		Inductance @0A _{DC} (μ H)	Saturation ³ Current (A) @25°C	Heating ⁴ Current (A)
			TYP	MAX			
PL9101	0.96	10.5	3.2	4.5	1.0*	12.7	10.5
PL9102	1.52	9.5	3.9	5.5	1.8*	10.1	9.5
PL9103	2.34	7.8	5.5	7.8	2.7*	8.4	7.8
PL9104	3.27	6.7	7.7	11	3.9*	7.2	6.7
PL9105	4.39	5.6	11	15.6	5.1*	6.3	5.6
PL9106	5.54	5.2	12.6	18	6.8*	5.6	5.2
PL9107	6.73	5.0	14	20	8.2*	5.1	5
PL9108	8.19	4.6	16	22	10	4.6	4.8
PL9109	9.90	4.2	20	27	12	4.2	4.3
PL9110	13.4	3.6	22	30	15	3.6	4
PL9111	15.4	3.4	31	40	18	3.4	3.4
PL9112	17.6	3.2	35	45	22	3.2	3.2
PL9113	22.5	2.8	47	62	27	2.8	2.8
PL9114	28.5	2.5	53	70	33	2.5	2.6
PL9115	31.4	2.4	55	75	39	2.4	2.5
PL9116	38.4	2.2	76	100	47	2.2	2.2
PL9117	48.3	1.9	87	110	56	1.9	2.1
PL9118	55.9	1.8	95	120	68	1.8	2
PL9119	67.6	1.7	133	178	82	1.7	1.7
PL9120	86.1	1.4	175	230	100	1.4	1.5
PL9121	103	1.3	192	253	120	1.3	1.4
PL9122	121	1.2	216	280	150	1.2	1.3
PL9123	149	1.1	242	310	180	1.1	1.2
PL9124	186	1.00	318	400	220	1.0	1.05
PL9125	224	0.91	370	460	270	0.91	0.96
PL9126	279	0.82	520	690	330	0.82	0.84
PL9127	335	0.72	571	760	390	0.72	0.8
PL9128	398	0.68	638	850	470	0.68	0.77
PL9129	464	0.63	844	1060	560	0.63	0.66
PL9130	563	0.57	943	1200	680	0.57	0.63
PL9131	681	0.52	1054	1550	820	0.52	0.6
PL9132	879	0.46	1418	1750	1000	0.46	0.5

*Inductance at 0A_{DC} tolerance on indicated part numbers is \pm 30%; tolerance is \pm 20% on all other parts. Optional Tape & Reel packaging can be ordered by adding a "T" suffix to the part number (i.e. PL9101 becomes PL9101T).

Mechanical

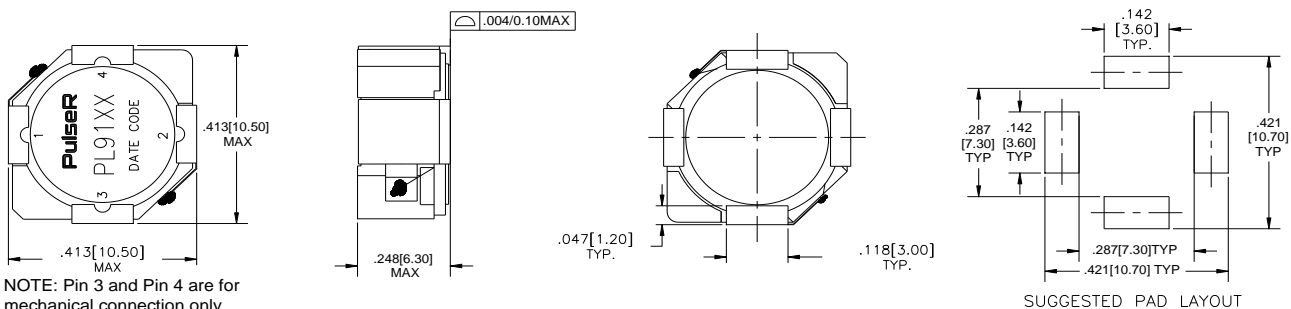

SMT POWER INDUCTORS

Shielded Drum Core - PL91XX Series

Ruggedized



Notes from Tables:

1. Temperature of the component (ambient plus temperature rise) must be within specified operating temperature range.
2. The rated current as listed is either the saturation current or the heating current depending on which value is lower.
3. The saturation current is the current which causes the inductance to drop to 75% of its initial inductance at zero bias. This current is determined by placing the component at room ambient (25°C), and applying a short duration pulse current (to eliminate self-heating effects) to the component.
4. The heating current is the DC current, which causes the temperature of the part to increase by approximately 40°C. This current is determined by extending the terminals of the component with 30mm length 28 gauge buss wires and applying the current to the device for 30 minutes. The temperature is measured by placing the thermocouple between the winding and the shield.
5. In high volt*time applications, additional heating in the component can occur due to core losses in the inductor which may necessitate derating the current in order to limit the temperature rise of the component. In order to determine the approximate total loss (or temperature rise) for a given application, both copper losses and core losses should be taken into account.

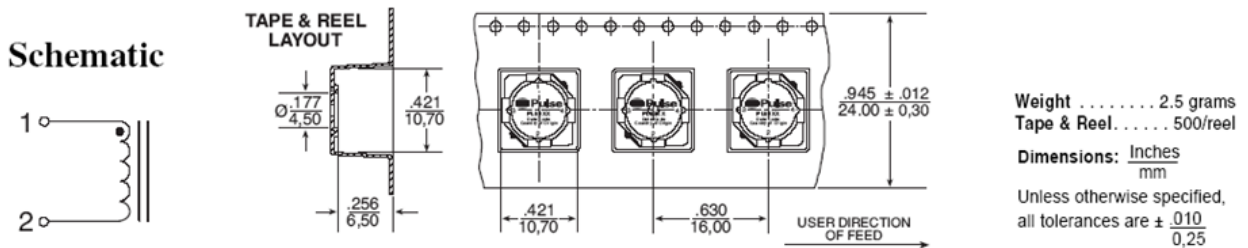

Inductance vs Current Characteristics

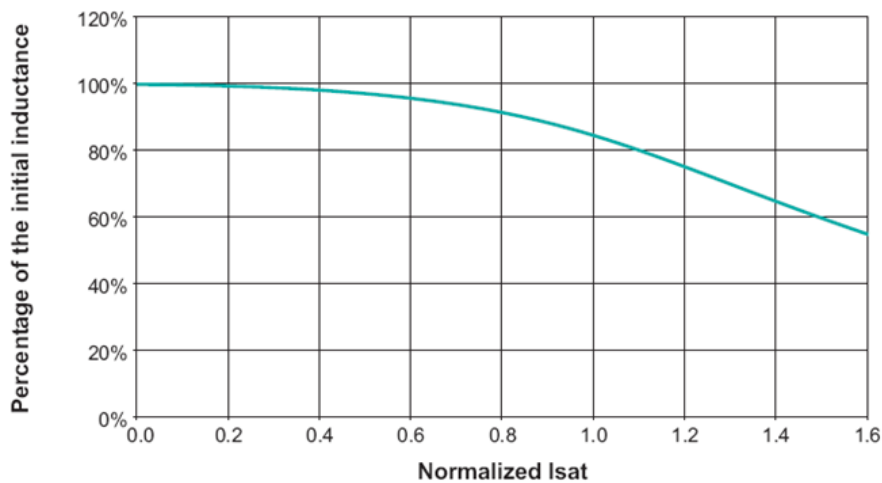

Transceiver Tin/Lead Recommended Reflow Profile (Based on J-STD-020D)

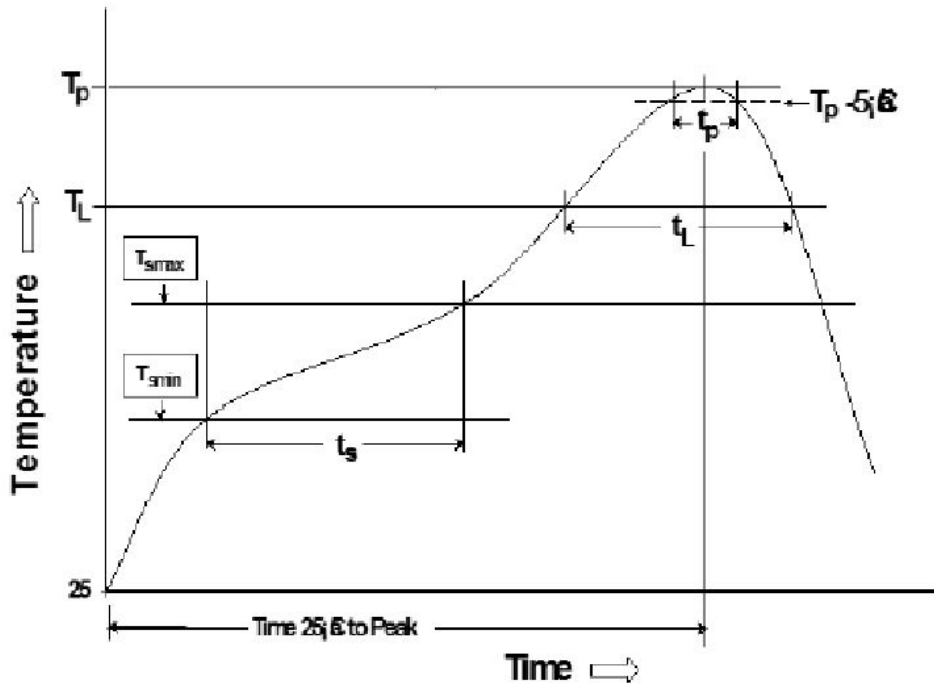

T_{SMIN} (°C)	T_{SMAX} (°C)	T_L (°C)	T_P (°C MAX)	t_s (s)	t_l (s)	t_p (s MAX)	Ramp-up rate (T_L to T_P)	Ramp-down rate (T_P to T_L)	Time 25°C to peak temperature (s MAX)
100	150	183	225	60-120	60-150	20	3°C/s MAX	6°C/s MAX	360

Notes:

1. All temperatures measured on the package leads.
2. Maximum times of reflow cycle: 2.

For More Information

**PulseR North America
 Headquarters**

Two Pearl Buck Court
 Bristol, PA 19007
 U.S.A.

Tel: +1.215.781.6400
 Fax: +1.215.781.6403

For Global Sales Representatives and Locations Visit:
<http://www.pulseruggedized.com>

Performance warranty of products offered on this data sheet is limited to the parameters specified. Data is subject to change without notice. Other brand and product names mentioned herein may be trademarks or registered trademarks of their respective owners. © Copyright, 2018. PulseR, LLC. All rights reserved.

X-ON Electronics

Largest Supplier of Electrical and Electronic Components

Click to view similar products for [Fixed Inductors](#) category:

Click to view products by [Pulse manufacturer](#):

Other Similar products are found below :

[MLZ1608M6R8WTD25](#) [MLZ1608N6R8LT000](#) [MLZ1608N3R3LTD25](#) [MLZ1608N3R3LT000](#) [MLZ1608N150LT000](#)
[MLZ1608M150WTD25](#) [MLZ1608M3R3WTD25](#) [MLZ1608M3R3WT000](#) [MLZ1608M150WT000](#) [MLZ1608A1R5WT000](#)
[MLZ1608N1R5LT000](#) [B82432C1333K000](#) [PCMB053T-1R0MS](#) [PCMB053T-1R5MS](#) [PCMB104T-1R5MS](#) [CR32NP-100KC](#) [CR32NP-151KC](#) [CR32NP-180KC](#) [CR32NP-181KC](#) [CR32NP-1R5MC](#) [CR32NP-390KC](#) [CR32NP-3R9MC](#) [CR32NP-680KC](#) [CR32NP-820KC](#)
[CR32NP-8R2MC](#) [CR43NP-390KC](#) [CR43NP-560KC](#) [CR43NP-680KC](#) [CR54NP-181KC](#) [CR54NP-470LC](#) [CR54NP-820KC](#) [CR54NP-8R5MC](#)
[MGDQ4-00004-P](#) [MGDU1-00016-P](#) [MHL1ECTTP18NJ](#) [MHL1JCTTD12NJ](#) [PE-51506NL](#) [PE-53601NL](#) [PE-53630NL](#) [PE-53824SNLT](#) [PE-62892NL](#) [PE-92100NL](#) [PG0434.801NLT](#) [PG0936.113NLT](#) [PM06-2N7](#) [PM06-39NJ](#) [HC2LP-R47-R](#) [HC2-R47-R](#) [HC3-2R2-R](#) [HC8-1R2-R](#)