

SMT Common Mode Chokes

SLIC/Shasta Series

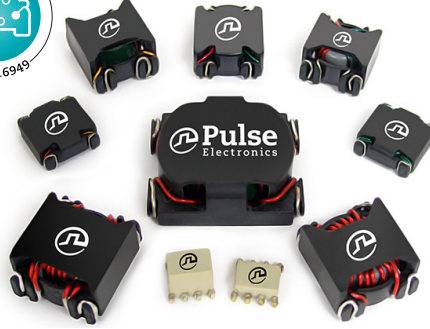

- ⊕ Wide variety of package sizes available
- ⊕ **Current Rating:** 2.8Arms to 20Arms
- ⊕ **Inductances Range:** 94uH to 1.8mH
- ⊕ **Dielectric strength:** 1500Vrms

Electrical Specifications at 25° C Temp Range -40 ° C to 125 ° C

Part Number	Irated ¹ (Arms or Adc)	Inductance ⁴ per Winding (uH +/-35%)	DCR per Winding (mΩ Max)	Leakage Inductance ⁵ (uH Min)	Typical SRF (MHz)	Typical Impedance at SRF (Ω)	Platform Name	Package Size (mm Max)	Weight (grms)	Quantity In Tube ³	Quantity in T&R ³
PM0351NL	2.8	1470	80	11.3*	2	10700	LCCI-50-1	19.6 x 17.0 x 9.9	4.3	30	200
PM0353NL	5.6	590	21	4.5*	4	4900	LCCI-50-1	19.6 x 17.0 x 9.9	5	30	200
PM0420NL	3.3	1320	60	8.5*	2.5	9600	LCCI-50-1	19.6 x 17.0 x 9.9	4.5	30	200
PM2741NL	1.1	94	30	0.3	15	450	Low Shasta	9.1 x 8.9 x 3.8	0.3	60	125
PM0354NL	1.22	1170	200	8.3*	3	8200	Polecat	12.7 x 12.7 x 8.4	1.4	40	500
PM0422NL	4.7	770	40	5.2*	3	6400	LCCI-50-1	19.6 x 17.0 x 9.9	4.7	30	200
PM0429NL	9.7	810	14	9.1*	3	6400	HCCI-80-2	31.0 x 25.4 x 12.7	15.2	20	75
PM0502NL	14	470	8	5.3*	3	3750	HCCI-80-2	31.0 x 25.4 x 12.7	16.2	20	75
PM0527NL	7.2	530	15	5.1*	4	3100	HCCI-68	28.2 x 25.4 x 10.0	7.3	20	100
PM2742NL	1	397	92	0.6	6	1500	High Shasta	9.1 x 8.9 x 7.9	0.6	50	400
PM53912NL⁶	2.5	1800*	80	-	2	5000	LCCI-50-3	19.6 x 17.0 x 9.9	4.9	30	200
PM3927NL ⁶	3	800	27	1.5	20	1300	Polecat	13.0 x 13.0 x 8.6	2.4	40	500
PM2743NL ⁶	3.3	383	18	1	2.5	1400	Polecat	13.0 x 13.0 x 5.6	1.7	40	500
PM2744NL ⁶	4	280	13.2	0.7	2	1000	Polecat	13.0 x 13.0 x 5.6	1.6	40	500
PM2750NL⁶	6	400	9.4	1.25	9	900	LCCI-44	18.2 x 15.0 x 10.0	3.5	30	200
PM2754NL⁶	10	215	3.75	0.5	4	600	Makeni	21.1 x 19.1 x 11.2	6.2	25	150
PM1265NL⁶	20	380	4.1	1.2	1	900	HCCI-80-2	31.0 x 25.4 x 12.7	14.5	20	75

NOTE:

1. The current rating (Irated) is based upon the temperature rise of the component and represents the rms current which will cause a typical temperature rise of 55C with 50LFM forced cooling
2. The temperature of the component (ambient plus temperature rise) must be within the stated operating temperature range.
3. Optional Tape & Reel packaging can be ordered by adding a "T" suffix to the part number (i.e. PM2741NL becomes PM2741NLT). Pulse complies to industry standard tape and reel specification EIA481.
4. Inductance values shown are all nominal +/- 35% except those identified with an asterisk (*) which indicates that the inductance is a minimum value.
5. Leakage inductance values as shown are the minimum value except those identified with an asterisk (*) which indicates the value shown is a typical value.
6. The identified parts with the R10K cores have a 115°C upper operating temperature range limitation due to the core curie temperature
7. The parts in regular font are completely automotive qualified i.e., AEC-Q200 qualified and launched on an IATF certified production line. The parts in bold font are considered AEC-Q200 compliant based on qualification testing of various designs in these platforms. However, the IATF launch per the Advanced Product Quality Planning (APQP) procedure has not been completed.
8. Please contact Pulse Electronics if a part is selected for automotive application design to ensure APQP and PPAP delivery can be completed in accordance with project milestones. Note that Pulse applies standard AEC-Q200 qualification. If a customer has a vibration requirement beyond this, Pulse may not be able to confirm that requirement with this series. The customer should then consider to conduct their own qualification testing and/or glue the component to the PCB.

Impedance Plots

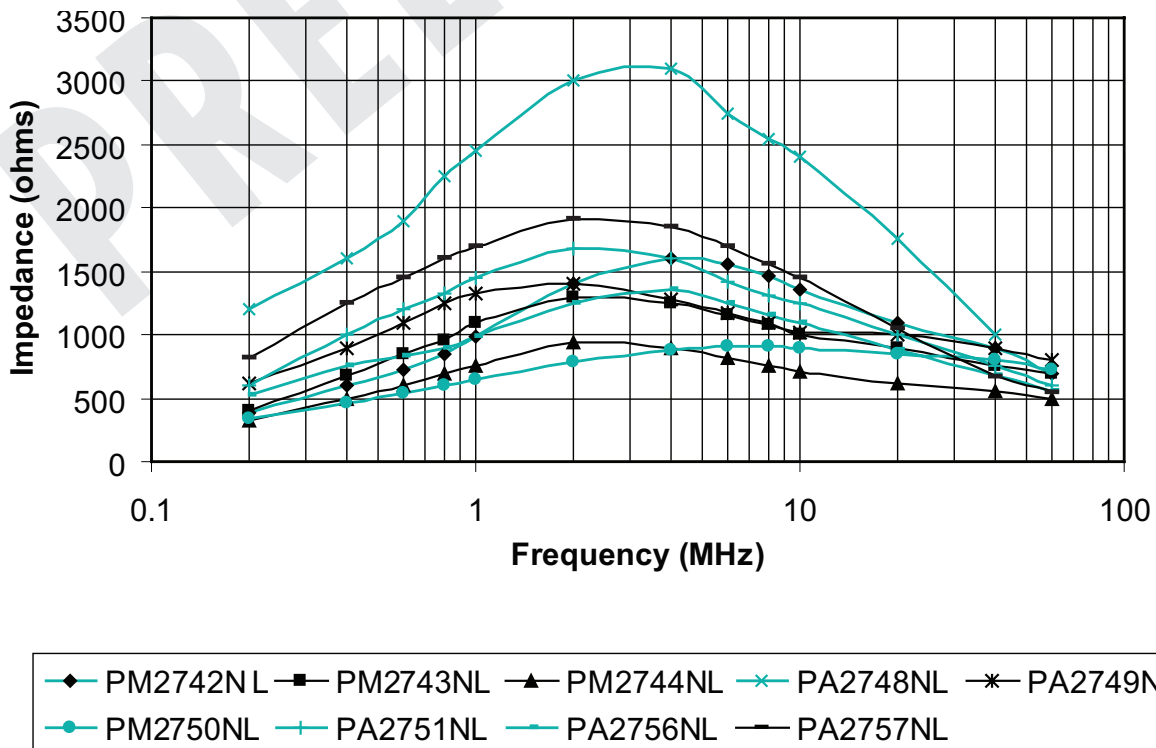
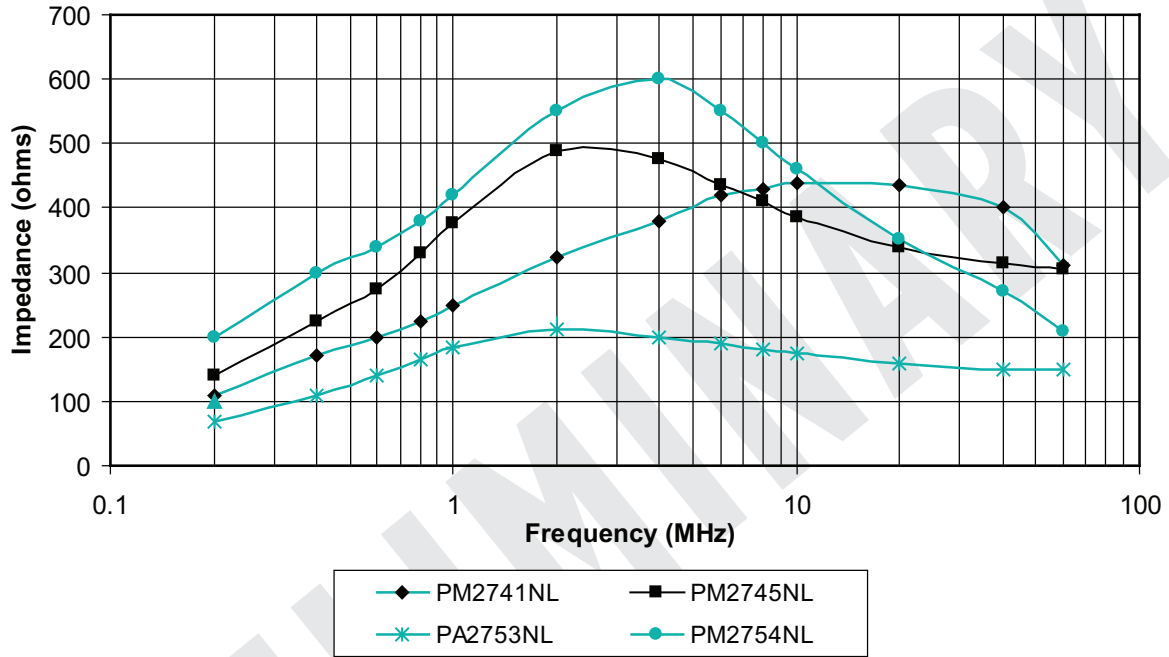

Impedance Plots

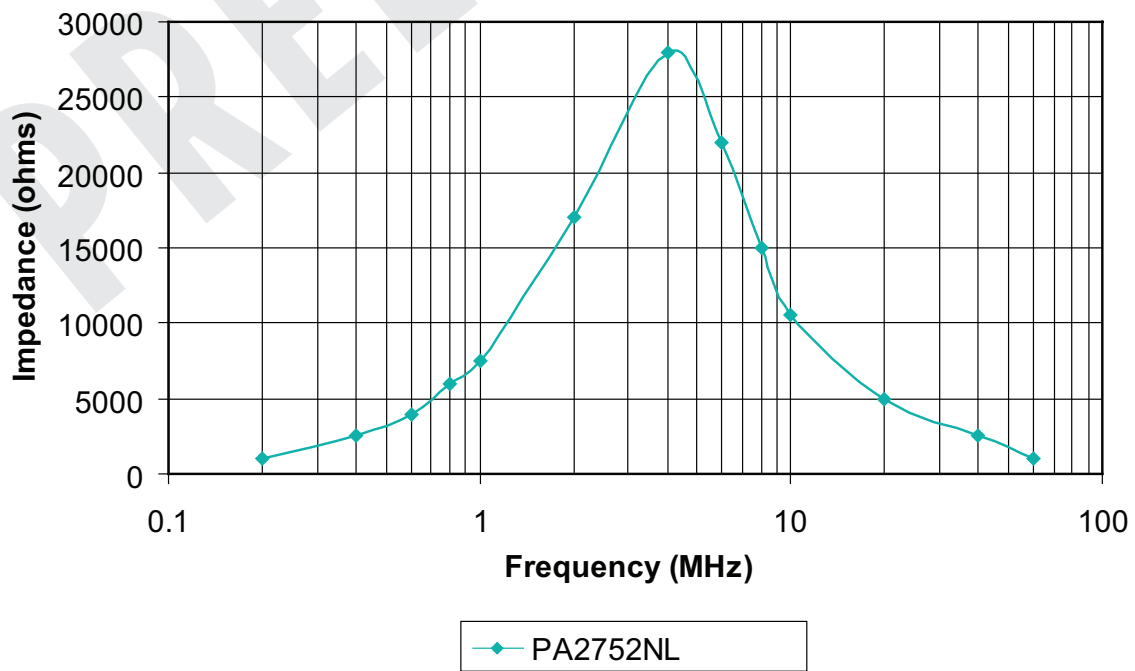
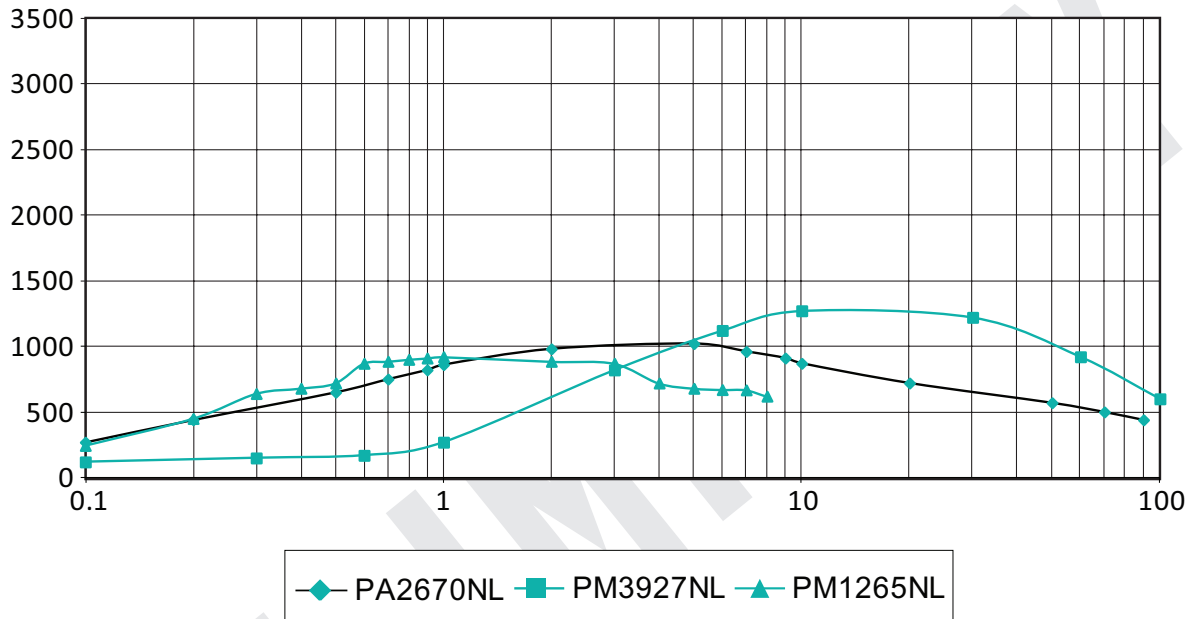

Impedance Plots

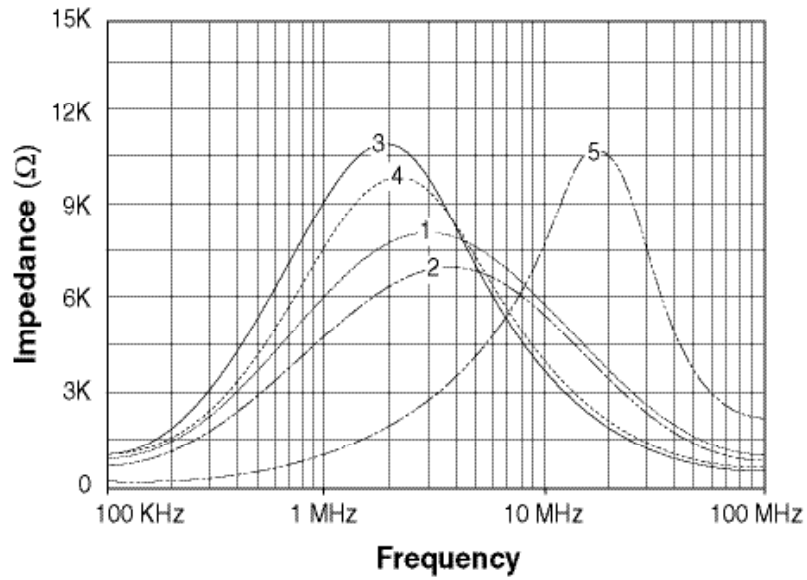

1 - PM0354NL	3 - PM0351NL	5 - PO421NL
2 - PO473NL	4 - PM0420NL	

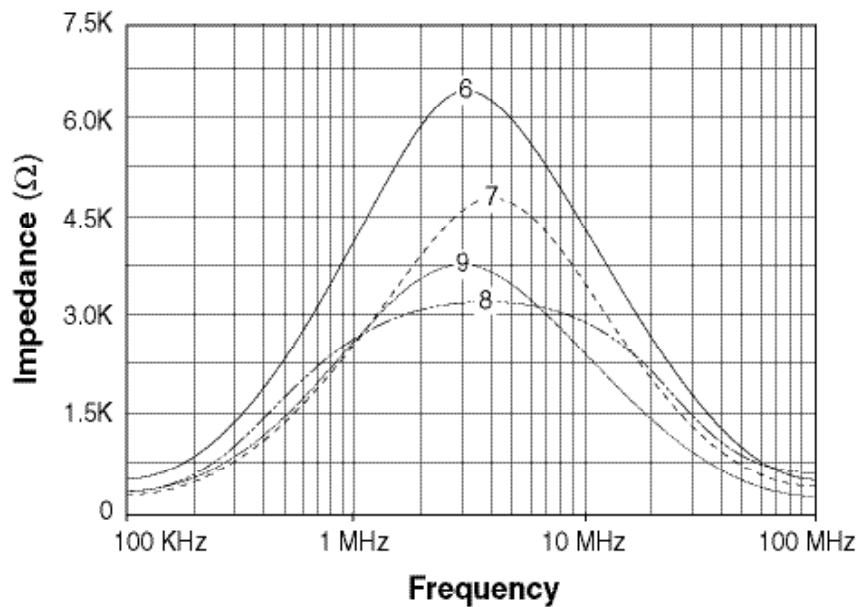

6 - PM0422NL, PM0429NL	8 - PM0527NL
7 - PM0353NL, PO469NL	9 - PM0502NL

Impedance Plots

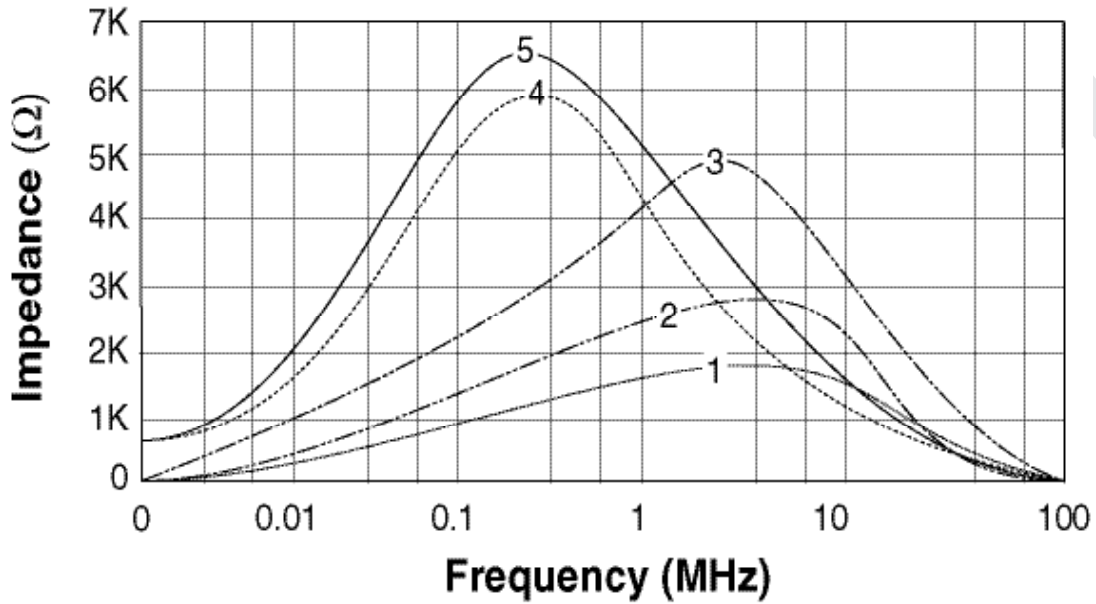

1 - PE-53910NL
2 - PE-53911NL

3 - PM53912NL
4 - PE-53913NL

5 - PE-53914NL

SMT Common Mode Chokes

SLIC/Shasta Series

Mechanicals

Low Shasta - PM2741NL

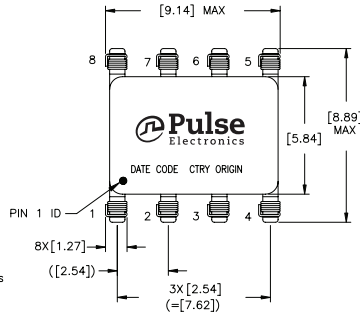
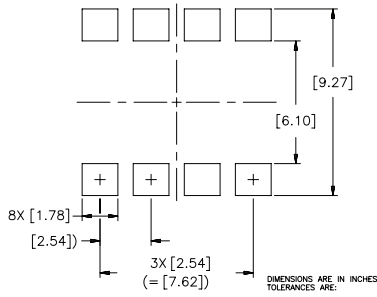

Schematic

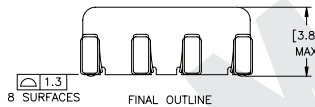
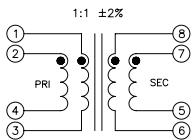

High Shasta - PM2742NL

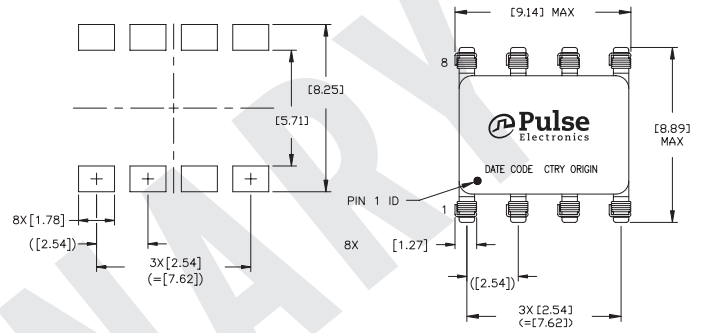

Schematic

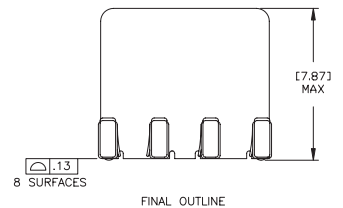
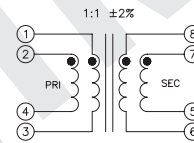

Please note that for PM2741NL and PM2742NL the part should be connected as follows:
Customer to connect pins (1,2) and (4,3) together on board to form a single winding (1,2-4,3).
Customer to connect pins (8,7) and (5,6) together on board to form a single winding (8,7-5,6).
All ratings (leakage and DCR) are with respect to the above winding configuration.

PoleCat - PM2743NL, PM2744NL, PA2745NL, PA2746NL, PA2747NL, PA2748NL, PM3927NL, P0473NL, and PM0354NL

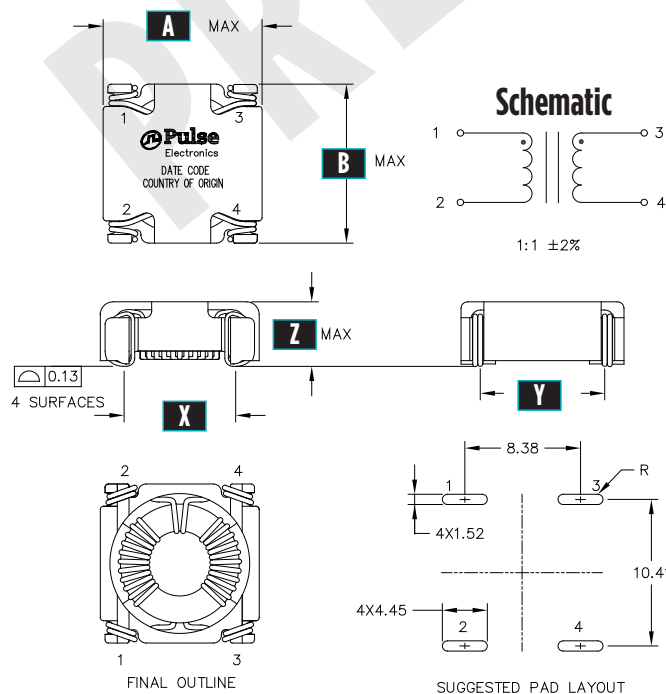

Polecat Dimensions

Part Number	A	B	X	Y	Z
PM2743NL	13.0	13.0	8.4	10.4	5.6
PM2744NL	13.0	13.0	8.4	10.4	5.6
PA2745NL	13.2	13.2	8.6	10.7	5.6
PA2746NL	13.2	13.2	8.6	10.7	5.6
PA2747NL	13.5	13.5	8.6	10.7	5.6
PA2748NL	12.7	13.2	8.4	10.4	5.6
PM3927NL	13.0	13.0	8.4	10.4	8.6
PA473NL	12.7	12.7	8.4	10.4	5.5
PM0354NL	12.7	12.7	8.4	10.4	5.5

SMT Common Mode Chokes

SLIC/Shasta Series

Mechanicals

LCCI-37-1 - PA2749NL

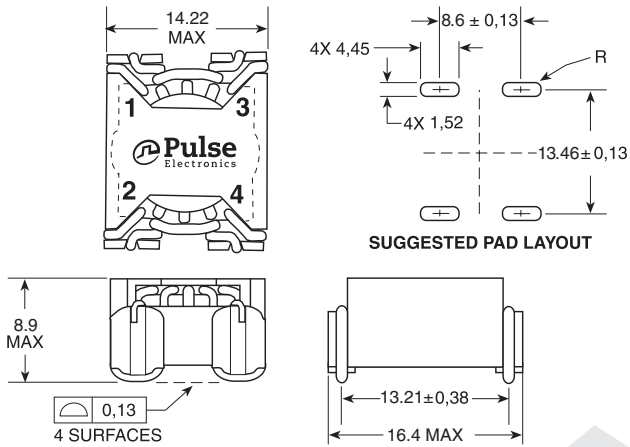

Schematic

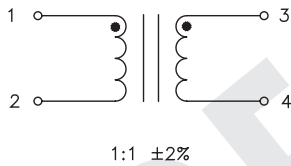

LCCI-44 - PM2750NL

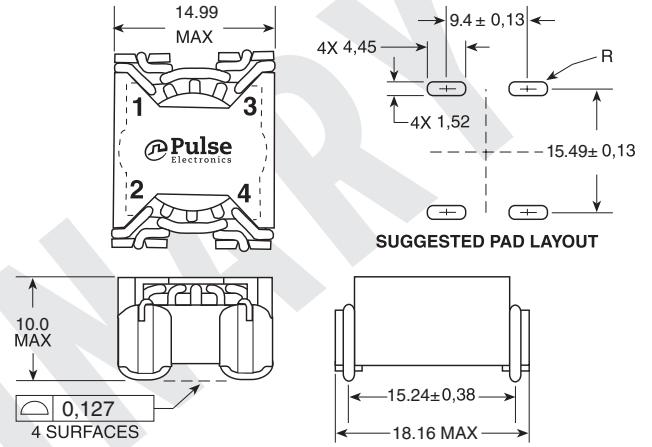

Schematic

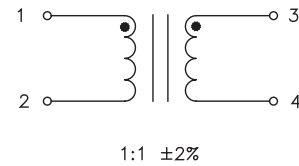

LCCI-44LP - PA2751NL

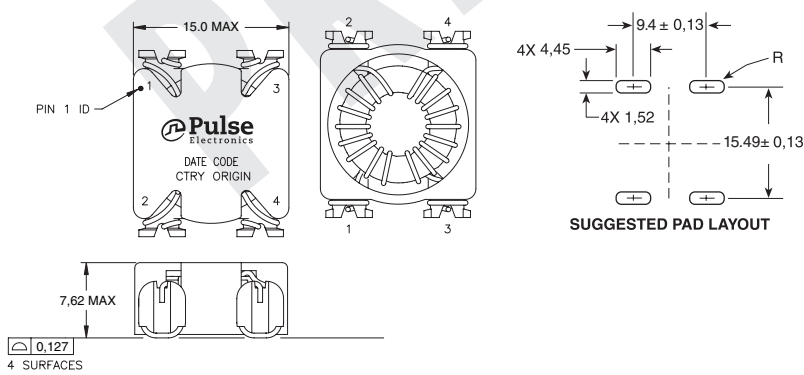

Schematic

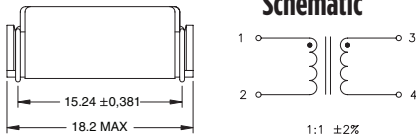

LCCI-50-1 - PA2752NL, PM0353NL, PM0422NL, PO421NL, PM0420NL, PM0351NL

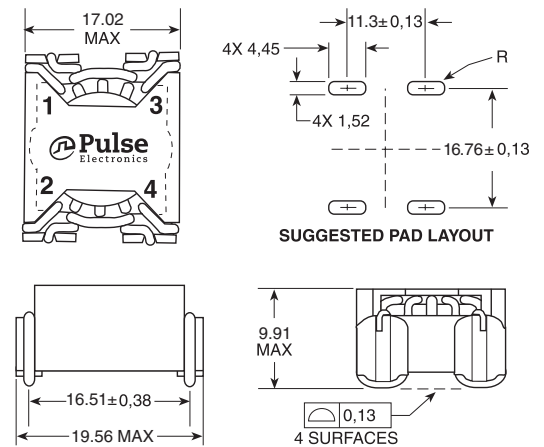

Schematic

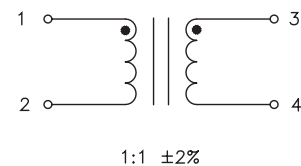

SMT Common Mode Chokes

SLIC/Shasta Series

Mechanicals

Schematics

LCCI-50-2 - PA2753NL and PA2756NL

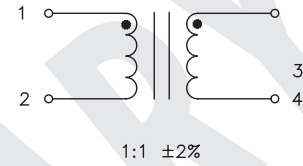
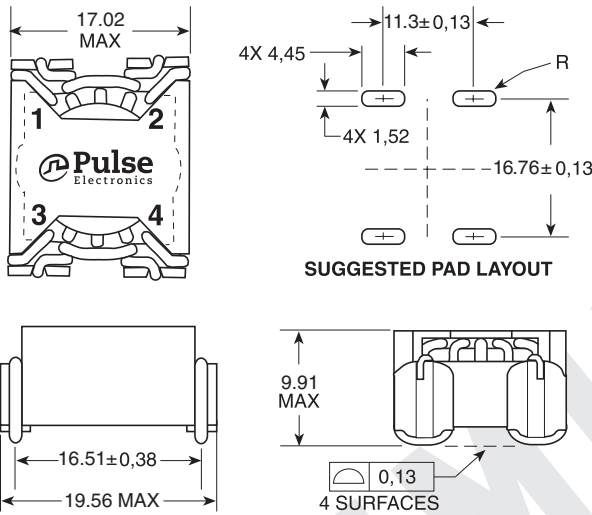

Mechanicals

Schematics

LCCI-37-2 & LCCI-50-3 - PE-5391xNL and PM53912NL

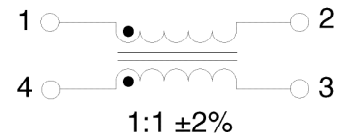
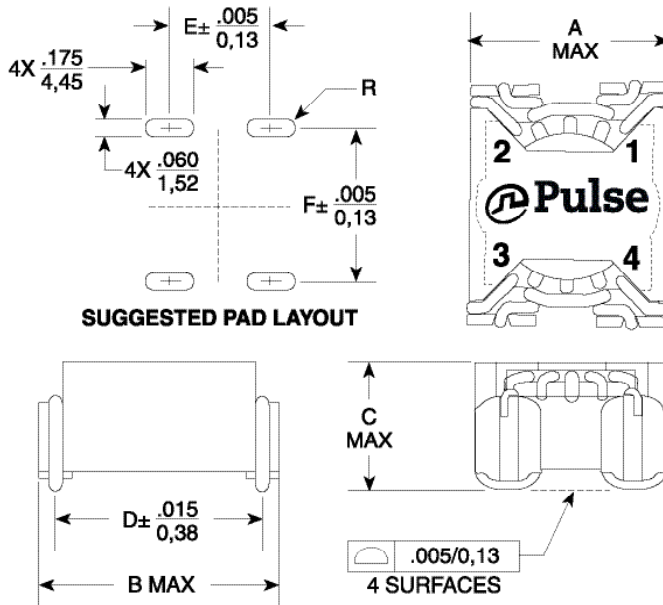

Size	A	B	C	D	E	F
LCCI-37-2	.560/14,22	.645/16,38	.350/8,89	.520/13,21	.340/8,64	.530/13,46
LCCI-50-3	.670/17,02	.770/19,56	.390/9,90	.650/16,51	.445/11,30	.660/16,76

SMT Common Mode Chokes

SLIC/Shasta Series

Mechanicals

Schematics

Makeni - PM2754NL, PA2755NL

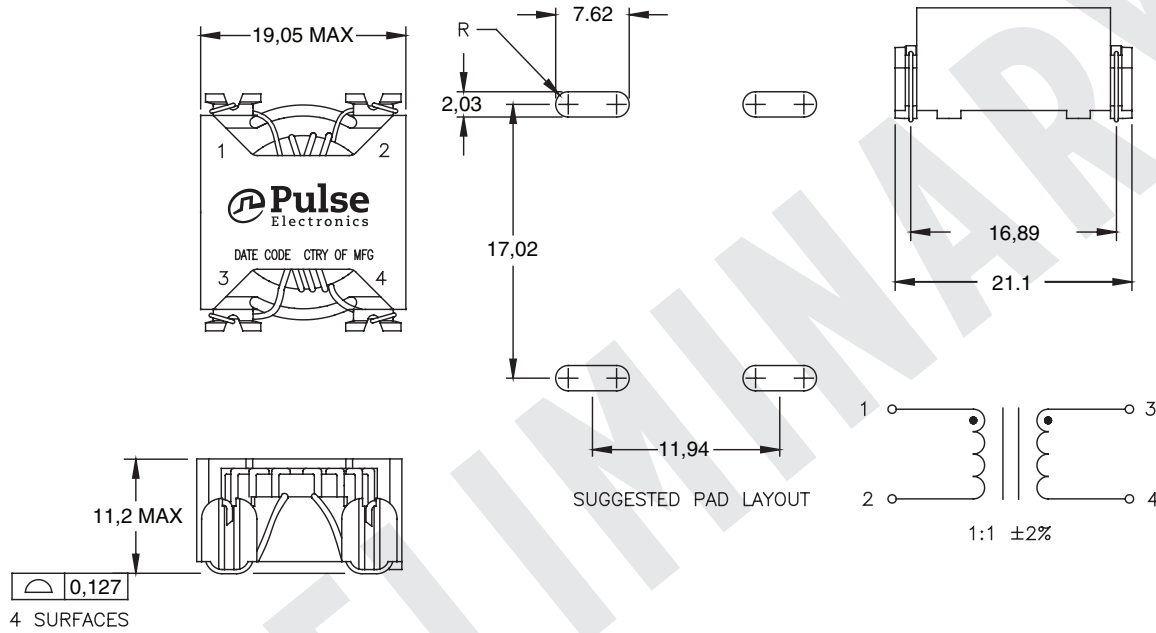

HCCI-68 - PM0527NL

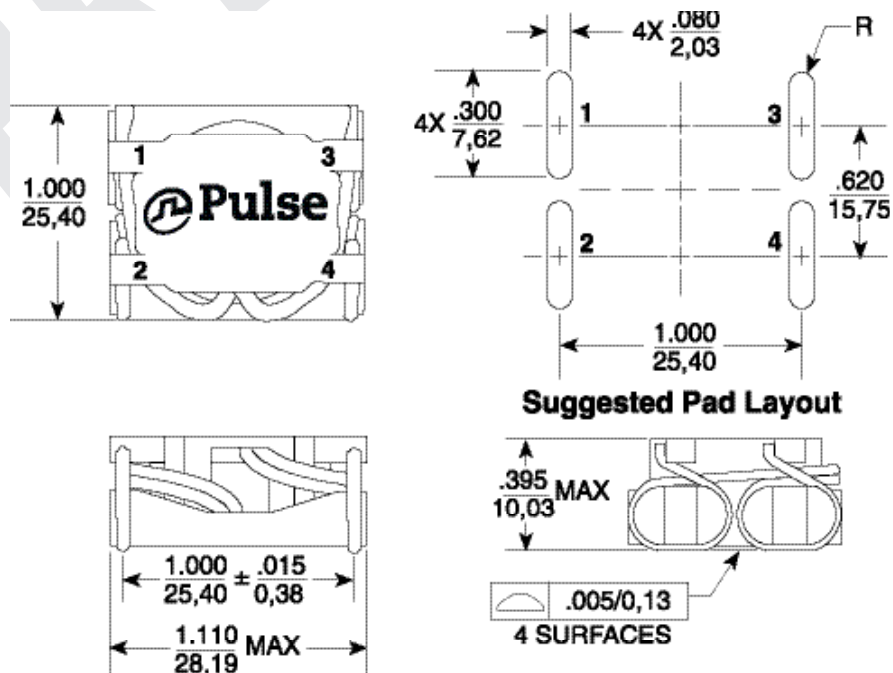

SMT Common Mode Chokes

SLIC/Shasta Series

Mechanical

Schematic

HCCI-80-1 - PA2757NL

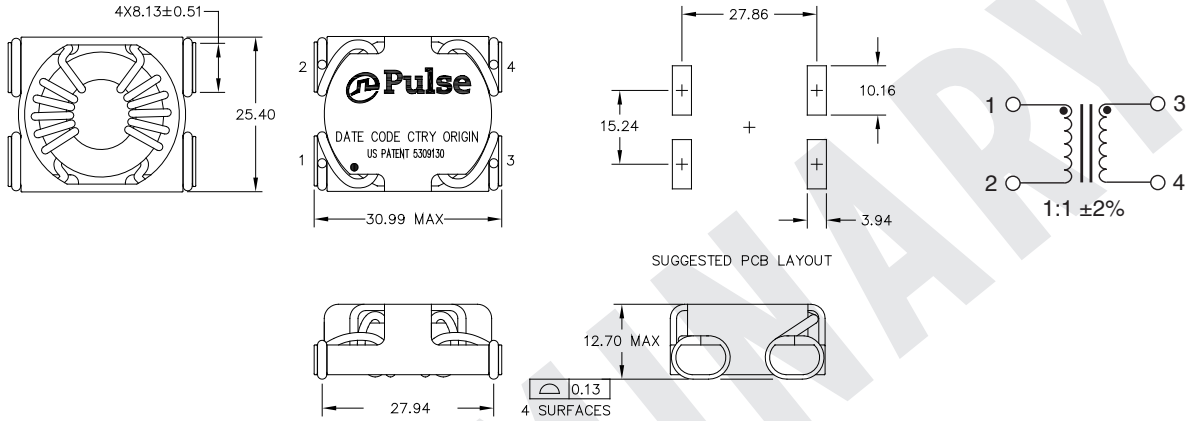

Mechanical

Schematic

HCCI-80-2 - PA2670NL, PM1265NL, PM0502NL, PM0469NL and PM0429NL

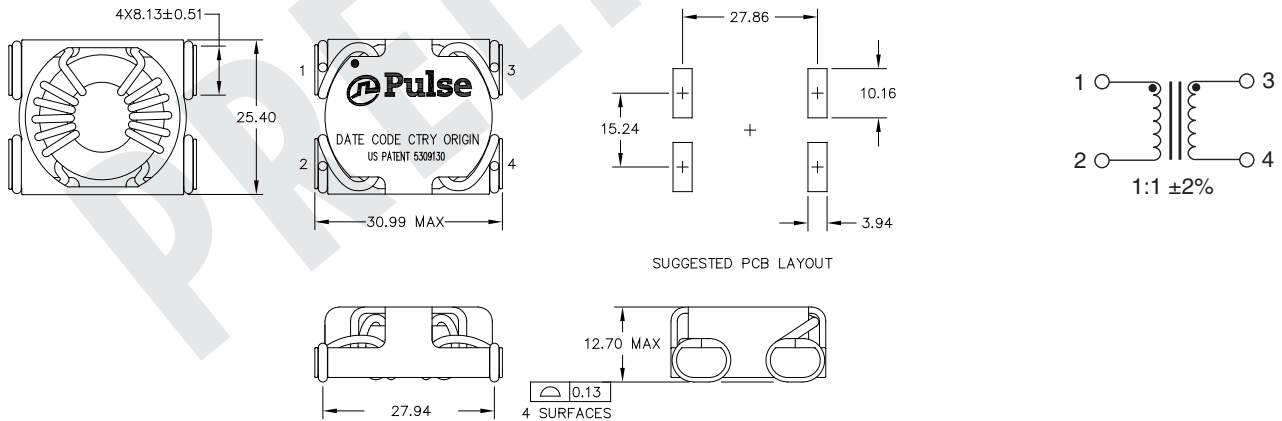

For More Information:

Americas - prodinfo_power_americas@yageo.com | Europe - prodinfo_power_emea@yageo.com | Asia - prodinfo_power_asia@yageo.com

Performance warranty of products offered on this data sheet is limited to the parameters specified. Data is subject to change without notice. Other brand and product names mentioned herein may be trademarks or registered trademarks of their respective owners. © Copyright, 2022. Pulse Electronics, Inc. All rights reserved.

X-ON Electronics

Largest Supplier of Electrical and Electronic Components

Click to view similar products for [Common Mode Chokes / Filters](#) category:

Click to view products by [Pulse manufacturer](#):

Other Similar products are found below :

[PE-64683](#) [RD5122-6-9M6](#) [ST6118T-R](#) [FE3X025-10-7NL](#) [T8114NLT](#) [TCM0806G-350-2P-T](#) [TCM0806G-650-2P-T](#) [IND-0110](#)
[UAL21VR0802000](#) [UALSC023000000](#) [UALSC1020JH000](#) [UALSU10VD20010](#) [UALSU9VD070100](#) [36-00037](#) [CM7060M132R-10](#)
[UALW21HS072450](#) [UALSU9H0208000](#) [UAL24VK06450CH](#) [PE-67531](#) [TLH10UB](#) [113 OR5](#) [2752045447](#) [CM8663Z161B-10](#) [7351V](#)
[CMF16-153131](#) [T8116NLT](#) [CMS2-10-R](#) [FE2X10-4-2NL](#) [T8003NLT](#) [CTX01-13663](#) [CTX66-19521-R](#) [RC212-0.5-10M](#) [RC112-0.4-15M](#)
[RC212-0.6-6M8](#) [RC212-0.4-15M](#) [RC112-0.3-30M](#) [4534-3](#) [WTCF2012Z0M751PB](#) [PH9408.814NLT](#) [B82498B3221J000](#) [PAC6006.364NLT](#)
[PAC6006.444NLT](#) [PAC6006.204NLT](#) [PH9407.204NLT](#) [PAC6006.264NLT](#) [PH9408.105NLT](#) [PH9408.494NLT](#) [PAC6006.104NLT](#)
[CM6350R-683-REEL](#) [CUW43T-513T-AU](#) [CUW43T-104T-AU](#)