



Features:

- Antenna type coil on ferrite core
- Frequency 13.56MHz
- Inductance 4.7uH
- Read Distance 17mm
- Size 7.8 x 7 x 5 mm
- Fully SMD compatible
- RoHS Compliant
- MSL level 3

Applications:

- RFID / NFC systems
- Pairing, Sharing

All dimensions are in mm / inches

Issue: 1851

In the effort to improve our products, we reserve the right to make changes judged to be necessary.

CONFIDENTIAL AND PROPRIETARY INFORMATION

This document contains confidential and proprietary information of Pulse Electronics, Inc. (Pulse) and is protected by copyright, trade secret and other state and federal laws. Its receipt or possession does not convey any rights to reproduce, disclose its contents, or to manufacture, use or sell anything it may describe. Reproduction, disclosure or use without specific written authorization of Pulse is strictly forbidden.

For more information:

Pulse Worldwide Headquarters
15255 Innovation Drive #100
San Diego, CA 92128
USA
Tel: 1-858-674-8100

Pulse/Larsen Antennas
18110 SE 34th St Bldg 2 Suite 250
Vancouver, WA 98683
USA
Tel: 1-360-944-7551

Europe Headquarters
Pulse GmbH & Do, KG
Zeppelinstrasse 15
Herrenberg, Germany
Tel: 49 7032 7806 0

Pulse (Suzhou) Wireless Products Co, Inc.
99 Huo Ju Road(#29 Bldg,4th Phase
Suzhou New District
Jiangsu Province, Suzhou 215009 PR China
Tel: 86 512 6807 9998



Description: 13.56MHz RFID/NFC SMD
Antenna

Series: Embedded NFC

PART NUMBER: W3102

ELECTRICAL SPECIFICATIONS

Antenna Type	coil
Frequency	13.56 MHz
Nominal Impedance	50 Ω /80 Ω
Self inductance	4.7uH
resistance	0.25 Ω
read distance	17mm

MECHANICAL SPECIFICATIONS

Size	7.8 X 7.0 X 5.0 mm
Weight	0.83 g
Antenna Material	Core: 7.8 X 5.0(SH)DR B3.0 DR7.8 X 5.0 B3.0 Wire: 2UEW

ENVIRONMENTAL SPECIFICATIONS

Operating Temperature	-40 ~ +125° C
Storage Temperature	-20 ~ +80° C
RoHS Compliant	Yes

Issue: 1851

In the effort to improve our products, we reserve the right to make changes judged to be necessary.

CONFIDENTIAL AND PROPRIETARY INFORMATION

This document contains confidential and proprietary information of Pulse Electronics, Inc. (Pulse) and is protected by copyright, trade secret and other state and federal laws. Its receipt or possession does not convey any rights to reproduce, disclose its contents, or to manufacture, use or sell anything it may describe. Reproduction, disclosure or use without specific written authorization of Pulse is strictly forbidden.

Description: 13.56MHz RFID/NFC SMD Antenna

Series: Embedded NFC

PART NUMBER: W3102

MECHANICAL DRAWING

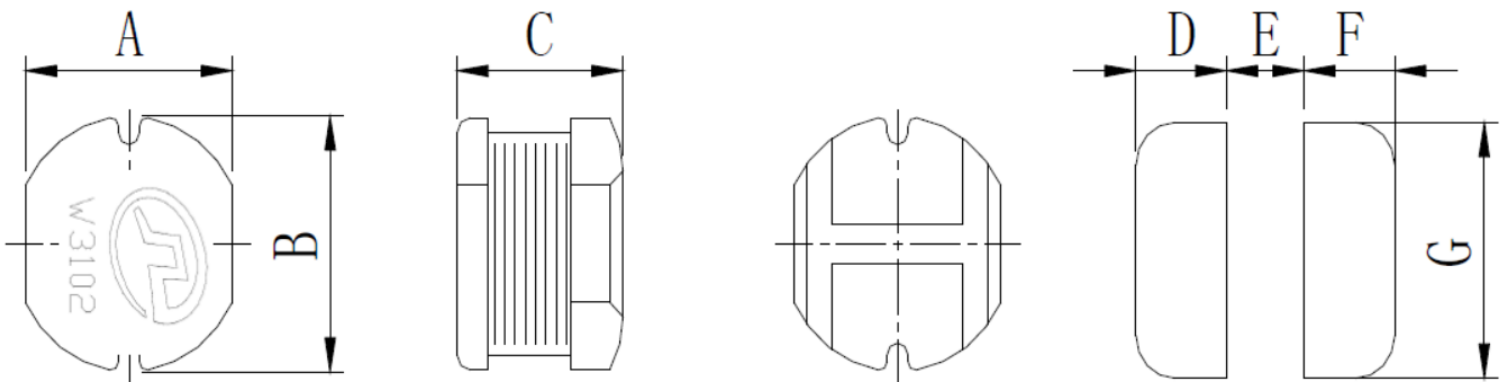

Recommend Solder Dimension

Dimension	A	B	C	D	E	F	G
Unit (mm/in)	7.0±0.3/0.28±0.01	7.8±0.3/0.31±0.01	5.0±0.35/0.20±0.01	2.5/0.10 Ref	2.7/0.11 Ref	2.5/0.10 Ref	7.5/0.30 Ref

Issue: 1851

In the effort to improve our products, we reserve the right to make changes judged to be necessary.

CONFIDENTIAL AND PROPRIETARY INFORMATION

This document contains confidential and proprietary information of Pulse Electronics, Inc. (Pulse) and is protected by copyright, trade secret and other state and federal laws. Its receipt or possession does not convey any rights to reproduce, disclose its contents, or to manufacture, use or sell anything it may describe. Reproduction, disclosure or use without specific written authorization of Pulse is strictly forbidden.

Description: 13.56MHz RFID/NFC SMD Antenna

Series: Embedded NFC

PART NUMBER: W3102

Reflow Soldering Temperature Profile Recommendation

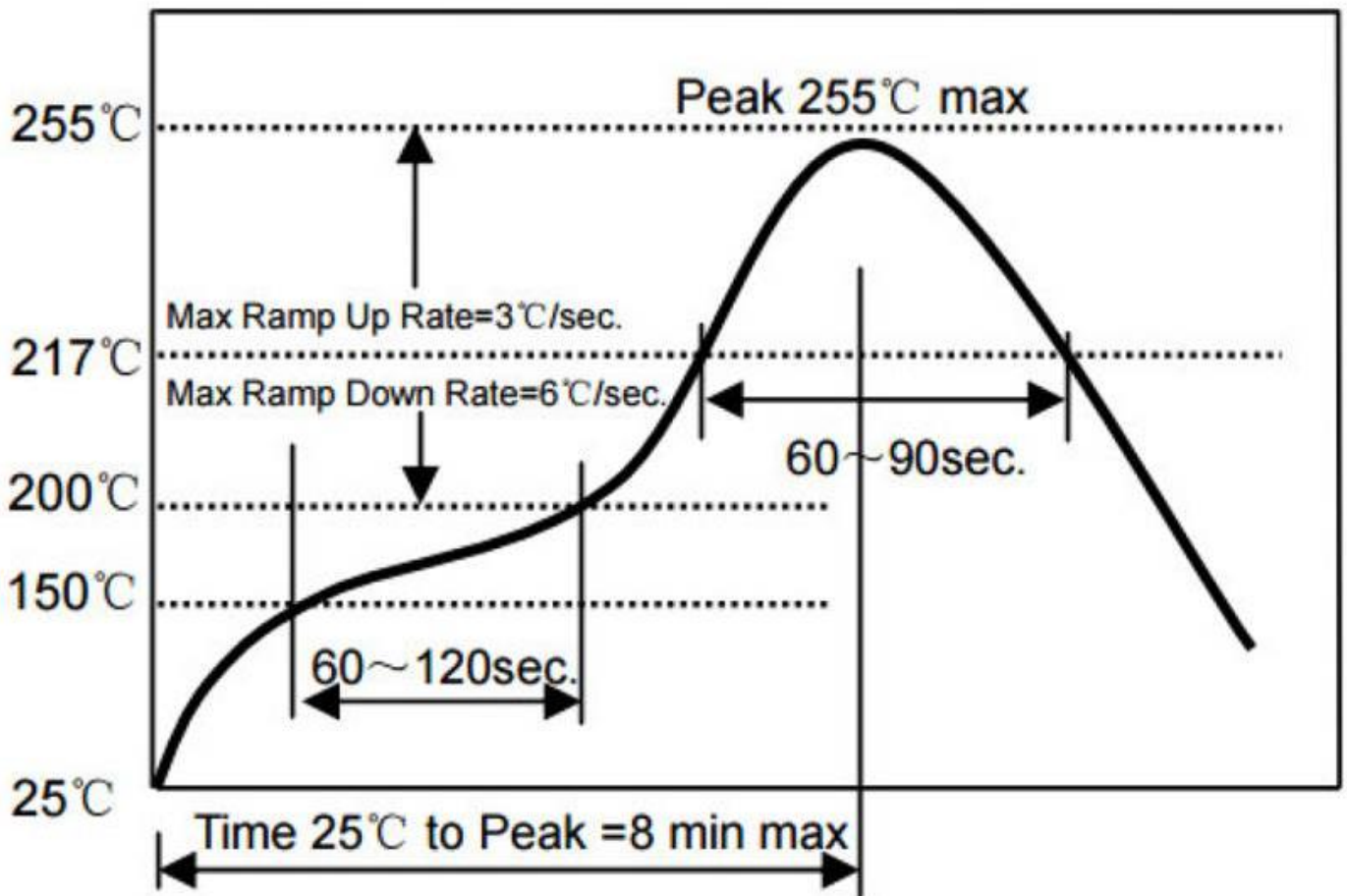

Issue: 1851

In the effort to improve our products, we reserve the right to make changes judged to be necessary.

CONFIDENTIAL AND PROPRIETARY INFORMATION

This document contains confidential and proprietary information of Pulse Electronics, Inc. (Pulse) and is protected by copyright, trade secret and other state and federal laws. Its receipt or possession does not convey any rights to reproduce, disclose its contents, or to manufacture, use or sell anything it may describe. Reproduction, disclosure or use without specific written authorization of Pulse is strictly forbidden.

Series: Embedded NFC

Description: 13.56MHz RFID/NFC SMD Antenna

PART NUMBER: W3102

TEST SETUP



ACR card reader

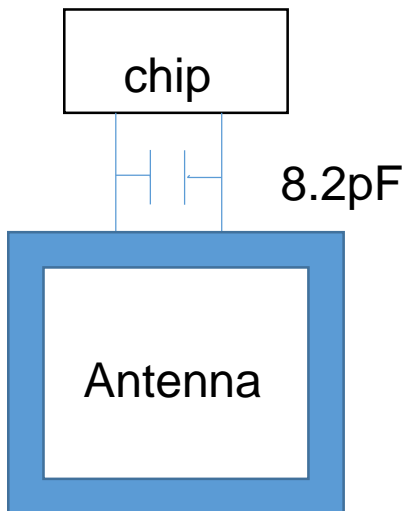

Matching circuit

Issue: 1851

In the effort to improve our products, we reserve the right to make changes judged to be necessary.

CONFIDENTIAL AND PROPRIETARY INFORMATION

This document contains confidential and proprietary information of Pulse Electronics, Inc. (Pulse) and is protected by copyright, trade secret and other state and federal laws. Its receipt or possession does not convey any rights to reproduce, disclose its contents, or to manufacture, use or sell anything it may describe. Reproduction, disclosure or use without specific written authorization of Pulse is strictly forbidden.

Description: 13.56MHz RFID/NFC SMD Antenna

Series: Embedded NFC

PART NUMBER: W3102

PACKAGING

1. Tape and reel packing with plastic vacuum bag.

1000 PCS/ REEL, 3 Reels/ Small BOX, 3 Small Boxes/ Big Box

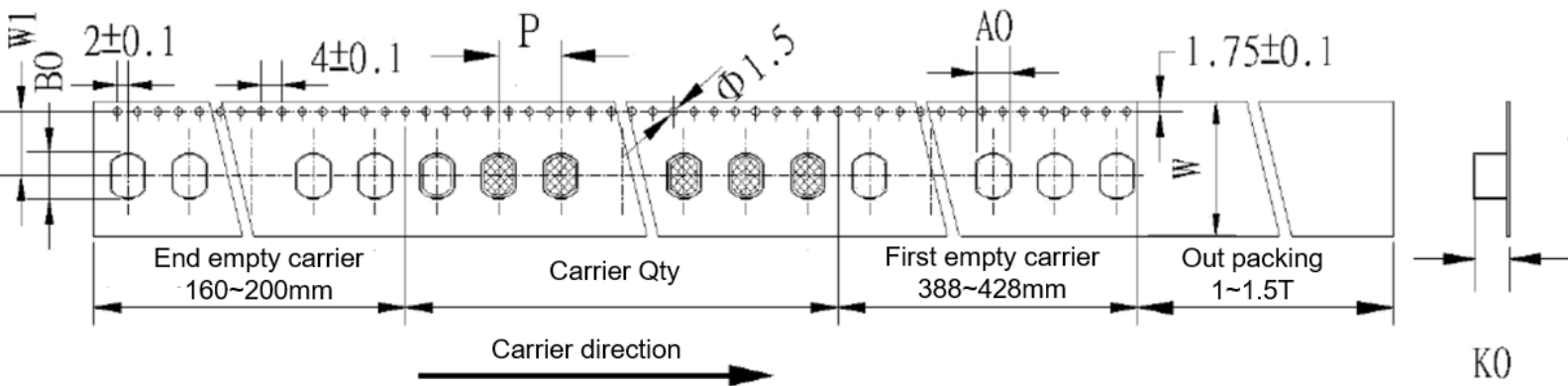

Type	Carrier Size						
	W	W1	T	P	A0	B0	K0
W3102	16	12.5	0.4	12	7.5	6.1	9.5

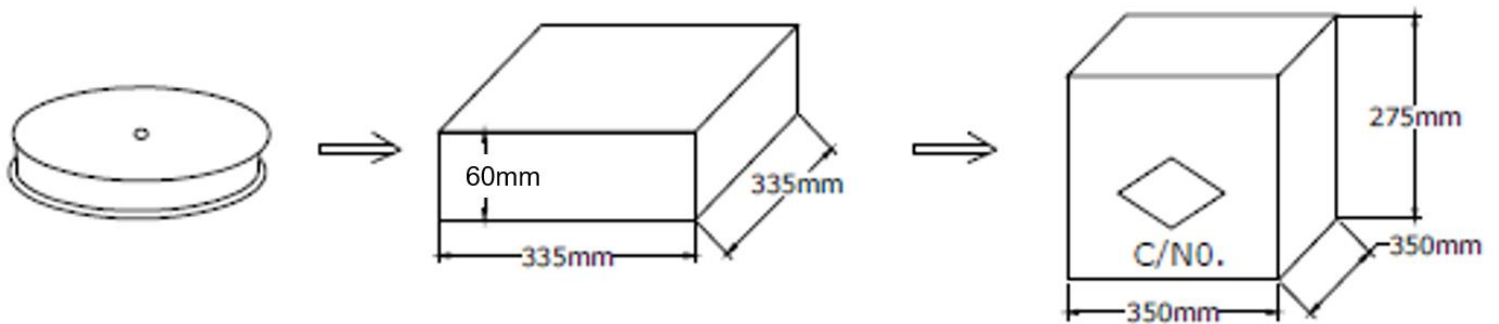

Issue: 1851

In the effort to improve our products, we reserve the right to make changes judged to be necessary.

CONFIDENTIAL AND PROPRIETARY INFORMATION

This document contains confidential and proprietary information of Pulse Electronics, Inc. (Pulse) and is protected by copyright, trade secret and other state and federal laws. Its receipt or possession does not convey any rights to reproduce, disclose its contents, or to manufacture, use or sell anything it may describe. Reproduction, disclosure or use without specific written authorization of Pulse is strictly forbidden.

Description: 13.56MHz RFID/NFC SMD
Antenna

Series: Embedded NFC

PART NUMBER: W3102

2. MSL: Level 3

2.1 Calculated shelf life in sealed bag: 12 months at $< 30^{\circ}\text{C}$ and 60% relative humidity (RH)

2.2 Peak temperature in reflow: 255°C Max

2.3 After bag is opened, devices that will be subjected to reflow solder or other temperature process must:

- a) Mount within: 168 hours of factory conditions $\leq 30^{\circ}\text{C}/60\%$
- b) stored at $< 20\%$ RH

2.4 Devices require bake, before mounting, if:

- a) Humidity Indicator Card is $> 20\%$ when read at $23 \pm 5^{\circ}\text{C}$
- b) 3a or 3b not met

2.5 If baking is required, devices may be baked for 24 hours at $125\sim 130^{\circ}\text{C}$

Issue: 1851

In the effort to improve our products, we reserve the right to make changes judged to be necessary.

CONFIDENTIAL AND PROPRIETARY INFORMATION

This document contains confidential and proprietary information of Pulse Electronics, Inc. (Pulse) and is protected by copyright, trade secret and other state and federal laws. Its receipt or possession does not convey any rights to reproduce, disclose its contents, or to manufacture, use or sell anything it may describe. Reproduction, disclosure or use without specific written authorization of Pulse is strictly forbidden.

X-ON Electronics

Largest Supplier of Electrical and Electronic Components

Click to view similar products for [Antennas](#) category:

Click to view products by [Pulse](#) manufacturer:

Other Similar products are found below :

[CCT FM1](#) [ABFT](#) [AD-NM-SMAF 001-0021](#) [CTC110](#) [MAF94149](#) [EXE902SF](#) [MMCX-SMA-100](#) [PDQ24496-91NF](#) [GAN30084EU](#) [930-033-R](#) [A08-HABUF-P5I](#) [AAF95035](#) [DG-ANT-20DP-BG-B](#) [ANT-DB1-RMT-SMA](#) [APAMPGJ-141](#) [1513563-1](#) [OF86315-FNF](#) [OP24516DS-91NM](#) [A09-HASM-7](#) [EXE902MD](#) [EXE902SM](#) [SPDA17806/2170LAR](#) [APAMPG-117](#) [GPS1575SP26-004](#) [GPS15MGSMA](#) [CMD69273P-30NF](#) [CMQ69273-30NF](#) [RD2458-5-OTDR-NM](#) [RD2458-5-RSMA](#) [TRAB24/49003](#) [TRAB8903NP](#) [TRAB9023NP](#) [TRAB9023P](#) [W4120ER5000](#) [W6102B0100](#) [YE572113-30RSMM](#) [108-00014-50](#) [SPDA17RP918](#) [OP24516SX-91NM](#) [OP24516SX-91RSMM](#) [CMQ69273P-30NF](#) [CMS69273-30NF](#) [CMS69273P-30NF](#) [TRAB24003N](#) [TRAB24003NP](#) [TRAB8213NP](#) [TRAB8903](#) [A09-Y8NF](#)