

Pulse Part Number W7002



The W7002 is a wire loop on plastic carrier product ideal for integration into products such as payment terminal devices or security access and control panels. By design, this antenna can be mounted around LCD or other types of displays, or placed around numeric keypads or control keypads.

The W7002 offers mounting features for machine screws or, with a partnered design approach, snapped into position using snap features. This part can be quickly changed to meet the needs of end-product by changing form-factor, and feeding mechanism.

Features

- Optimized for metal proximity within the device
- LCD module can be placed inside the antenna perimeter
- Ready mounting features to device mechanics
- Well-known antenna concept ready for production
- RoHS compliant product

Applications

- Portable and fixed devices
- Payment, sharing, pairing and connect to tags

Standards

- ISO/IEC 14443 A / B (MIFARE)
- ISO/IEC 18092
- JIS X 6319-4/FeliCa)
- NFCIP-1 / ECMA 3-40

Electrical Specifications

Frequency [MHz]*	13.56
Reading Distance [mm]*	40 EMVCo 35 Grid Scan (avg)
Impedance [Ω]*	50 / 80
Self Resonance Frequency [MHz]**	89
Inductance [μ H]**	0.65
Resistance [Ω]**	0.95
Q-Factor**	57
Matched Q Value***	5-30

Environmental Specifications

Operating Temperature [$^{\circ}$ C]	-40 to +85
---------------------------------------	------------

Mechanical Specifications

Color	Black
Dimensions [in/mm]	3.72 x 2.24 x 0.14 (94.6 x 56.8 x 3.65)

NOTE: Electrical characteristics depend on distance from metal objects and the location of the antenna on the device. Measured in free space

* With matching network

** Bare coil without any matching network

*** With matching network (adjustable). Typical network picture refer to page 2.

NFC Wire Loop Antenna

Pulse Part Number W7002

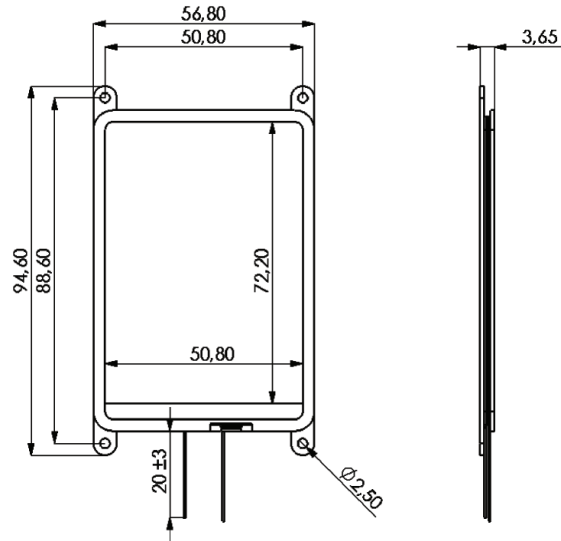

Recommended matching network

Component	Value	Note
L _{mc}	560 nH	Filter resonance at 15.4 MHz
C _{mc}	180 pF	Filter resonance at 15.4 MHz
C1	25 pF	Antenna matching component, value depends on the antenna environment Antenna matching
C2	180 pF	Antenna matching component, value depends on the antenna environment Antenna matching
R _q	0 Ohm	R _q resistors used to lower Q-value

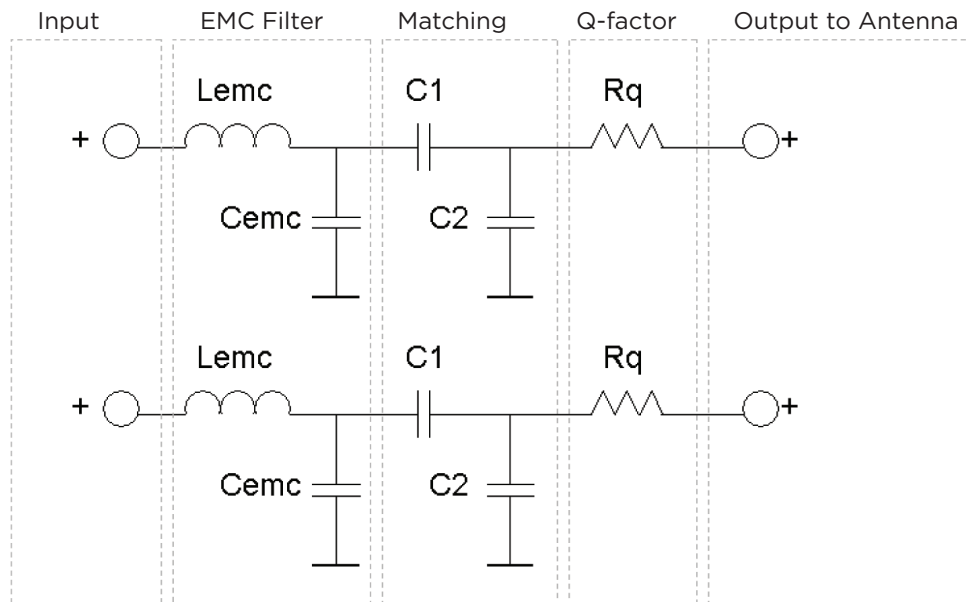

X-ON Electronics

Largest Supplier of Electrical and Electronic Components

Click to view similar products for [Antennas](#) category:

Click to view products by [Pulse](#) manufacturer:

Other Similar products are found below :

[GAN30084EU](#) [930-033-R](#) [GW17.07.0250E](#) [1513563-1](#) [EXE902SM](#) [APAMPG-117](#) [MAF94383](#) [W3908B0100](#) [W6102B0100](#) [YE572113-30RSMM](#) [108-00014-50](#) [66089-2406](#) [SPDA17RP918](#) [A09-F8NF-M](#) [A09-F5NF-M](#) [RGFRA1903041A1T](#) [W3593B0100](#) [W3921B0100](#) [SIMNA-868](#) [SIMNA-915](#) [SIMNA-433](#) [W1044](#) [W1049B090](#) [A75-001](#) [WTL2449CQ1-FRSMM](#) [CPL9C](#) [EXB148BN](#) [0600-00060](#) [TRA9020S3PBN-001](#) [GD5W-28P-NF](#) [MA9-7N](#) [GD53-25](#) [GD5W-21P-NF](#) [C37](#) [MAF94051](#) [MA9-5N](#) [EXD420PL](#) [B1322NR](#) [QWFTB120](#) [MAF94271](#) [MAF94300](#) [GPSMB301](#) [FG4403](#) [AO-AGSM-OM54](#) [5200232](#) [MIKROE-2349](#) [WCM.01.0111](#) [MIKROE-2393](#) [MIKROE-2352](#) [MIKROE-2350](#)