

## 800MA Bipolar Linear Regulator

### General Description

AMS1117 is a series of low dropout three-terminal regulators with a dropout of 1.3V at 800mA load current. AMS1117 features a very low standby current 2mA compared to 5mA of competitor.

Other than a fixed version,  $V_{out} = 1.2V, 1.8V, 2.5V, 2.85V, 3.3V,$  and  $5V,$  AMS1117 has an adjustable version, which can provide an output voltage from 1.25 to 12V with only two external resistors.

AMS1117 offers thermal shut down function, to assure the stability of chip and power system. And it uses trimming technique to guarantee output voltage accuracy within 2%. Other output voltage accuracy can be customized on demand, such as 1%.

AMS1117 is available in SOT-223, TO-252 power package.

### Features

- Maximum output current is 1.2A
- Range of operation input voltage: Max 15V
- Line regulation: 0.03%/V (typ.)
- Standby current: 2mA (typ.)
- Load regulation: 0.2%/A (typ.)
- Environment Temperature:  $-20^{\circ}C \sim 85^{\circ}C$

### Applications

- Power Management for Computer Mother Board, Graphic Card
- LCD Monitor and LCD TV
- DVD Decode Board
- ADSL Modem
- Post Regulators For Switching Supplies

### Typical Application

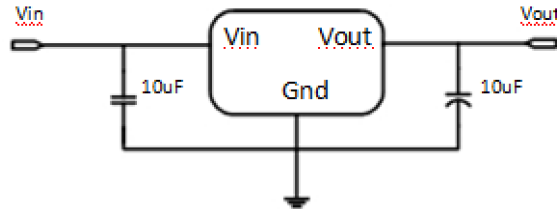

Application circuit of AMS1117 fixed version

### Typical Electrical Characteristic

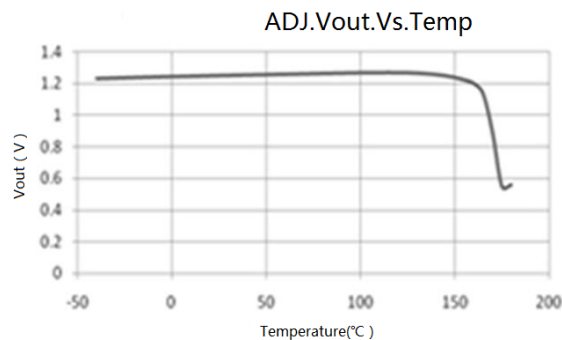

## 800MA Bipolar Linear Regulator

**Selection Table**

Marking	Part No.	Output Voltage	Package
AMS1117 XX YYWW	XX=12	1.2V	SOT-223
	XX=18	1.8V	
	XX=28	2.85V	
	XX=25	2.5V	
	XX=33	3.3V	
	XX=50	5.0V	
	XX=AD	Adj	

Parameters	Description
Temperature & Rohs	C:-40~85°C ,Pb Free Rohs Std.
Package type	L:SOT-223 O:TO-252
Packing type:	TR: Tape & Reel (Standard)
Voltage accuracy	2%(Customized)

**Block Diagram**

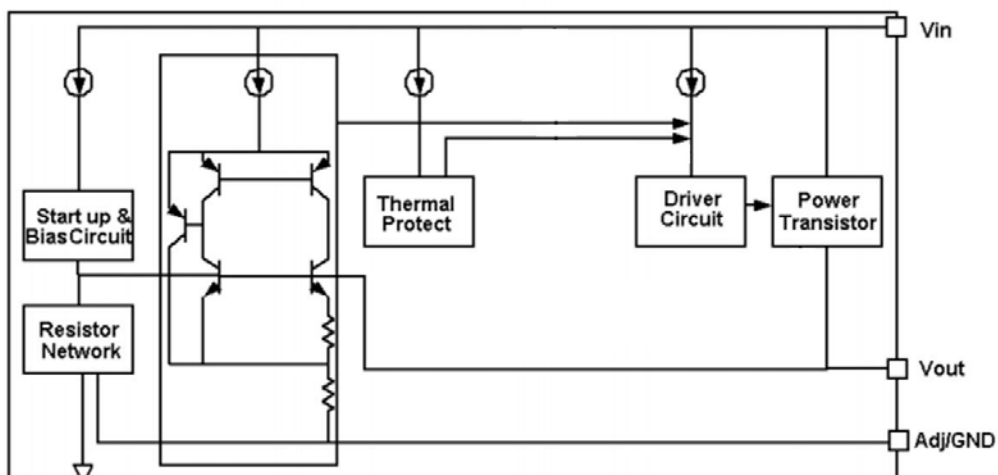

## 800MA Bipolar Linear Regulator

### Pin Configuration

TO-252 Top View      SOT-223 Top View

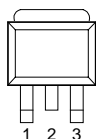

1: GND/ADJ  
2: VOUT  
3: VIN

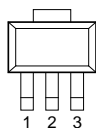

1: GND/ADJ  
2: VOUT  
3: VIN

### Absolute Maximum Ratings

Max Input Voltage .....	..30V
Max Operating Junction Temperature(Tj) .....	..150°C
Ambient Temperature(Ta) .....	..-40°C~ 85°C
Storage Temperature(Ts).....	.. -40°C~150°C
Lead Temperature & Time.....	..260°C 10S

Caution: Exceed these limits to damage to the device. Exposure to absolute maximum rating conditions may affect device reliability.

### Recommended Work Conditions

Recommended maximum input voltage.....	15V
Recommended operating junction temperature(Tj) .....	-20~125°C

### Thermal Information

Parameter	Package	Rating	Unit
Package thermal resistance	SOT-223	20	°C/W
	TO-252	12.5	°C/W

## 800mA Bipolar Linear Regulator

## Electrical Characteristics

T<sub>A</sub>=25°C, unless otherwise noted.

Symbol	Parameter	Condition	Min.	Typ.	Max.	Unit
V <sub>ref</sub>	Reference voltage	I <sub>out</sub> =10mA, V <sub>in</sub> -V <sub>out</sub> =2V 10mA ≤ I <sub>out</sub> ≤ 1A, 1.5V ≤ V <sub>in</sub> -V <sub>out</sub> ≤ 12V	1.238 1.225	1.25 1.25	1.262 1.275	V
V <sub>out</sub>	Output voltage	AMS1117-1.8V I <sub>out</sub> =10mA, V <sub>in</sub> =3.8V, T <sub>j</sub> =25°C 0 ≤ I <sub>out</sub> ≤ 800mA, 3.2V ≤ V <sub>in</sub> ≤ 12V	1.782 1.764	1.80 1.80	1.818 1.836	V
		AMS1117-2.5V I <sub>out</sub> =10mA, V <sub>in</sub> =4.5V, T <sub>j</sub> =25°C 0 ≤ I <sub>out</sub> ≤ 800mA, 3.9V ≤ V <sub>in</sub> ≤ 12V	2.475 2.45	2.5 2.5	2.525 2.55	V
		AMS1117-2.85V I <sub>out</sub> =10mA, V <sub>in</sub> =4.85V, T <sub>j</sub> =25°C 0 ≤ I <sub>out</sub> ≤ 800mA, 4.25V ≤ V <sub>in</sub> ≤ 12V	2.822 2.793	2.85 2.85	2.878 2.907	V
		AMS1117-3.3V I <sub>out</sub> =10mA, V <sub>in</sub> =5V, T <sub>j</sub> =25°C 0 ≤ I <sub>out</sub> ≤ 800mA, 4.75V ≤ V <sub>in</sub> ≤ 12V	3.267 3.234	3.3 3.3	3.333 3.366	V
		AMS1117-5.0V I <sub>out</sub> =10mA, V <sub>in</sub> =7V, T <sub>j</sub> =25°C 0 ≤ I <sub>out</sub> ≤ 800mA, 6.5V ≤ V <sub>in</sub> ≤ 12V	4.95 4.9	5 5	5.05 5.1	V

ΔV <sub>out</sub>	Line regulation (note1)	AMS1117-ADJ I <sub>out</sub> =10mA, 1.5V ≤ V <sub>in</sub> -V <sub>out</sub> ≤ 13.775V		0.035	0.2	%
		AMS1117-1.8V I <sub>out</sub> =10mA, 3.2V ≤ V <sub>in</sub> ≤ 15V		9	18	mV
		AMS1117-2.5V I <sub>out</sub> =10mA, 3.9V ≤ V <sub>in</sub> ≤ 15V		9	18	mV
		AMS1117-2.85V I <sub>out</sub> =10mA, 4.25V ≤ V <sub>in</sub> ≤ 15V		9	18	mV
		AMS1117-3.3V I <sub>out</sub> =10mA, 4.75V ≤ V <sub>in</sub> ≤ 15V		9	18	mV
		AMS1117-5.0V I <sub>out</sub> =10mA, 6.5V ≤ V <sub>in</sub> ≤ 15V		9	18	mV

## 800MA Bipolar Linear Regulator

ΔVout	Load regulation	AMS1117-2.5V Vin =3.9V, 10mA ≤ Iout ≤ 800mA		3	18	mV
		AMS1117-2.85V Vin=4.25V, 0 ≤ Iout ≤ 800mA		3	18	mV
		AMS1117-3.3 Vin=4.75V, 0 ≤ Iout ≤ 800mA		3	18	mV
		AMS1117-5.0 Vin=6.5V, 0 ≤ Iout ≤ 800mA		3	18	mV
Vdrop	Dropout voltage	Iout =100mA		1.11	1.3	V
		Iout=500mA		1.18	1.4	V
Imin	Minimum load current	AMS1117-ADJ		5	10	mA
Iq	Quiescent Current	AMS1117-1.8V, Vin-Vout=1.25V		4	8	mA
		AMS1117-2.5V, Vin-Vout=1.25V		4	8	mA
		AMS1117-2.85V, Vin-Vout=1.25V		4	8	mA
		AMS1117-3.3V, Vin-Vout=1.25V		4	8	mA
		AMS1117-5.0V, Vin-Vout=1.25V		4	8	mA

IAdj	Adjust Pin Current (Adjustable Version)			55	120	uA
Ichange	Adjust Pin Current Change			0.2	10	uA
	Temperature Stability				0.5	%
θJC	Thermal resistor			20		°C / W

Note1: All test are conducted under ambient temperature 25° C and within a short period of time 20ms

Note2: Load current smaller than minimum load current ofAMS1117-ADJ will lead to unstable or oscillation output.

## 800MA Bipolar Linear Regulator

### Detailed Description

AMS1117 is a series of low dropout voltage, three terminal regulators. Its application circuit is very simple: the fixed version only needs two capacitors and the adjustable version only needs two resistors and two capacitors to work. It is composed of some modules including start-up circuit, bias circuit, bandgap, thermal shutdown, power transistors and its driver circuit and so on.

The thermal shut down modules can assure chip and its application system working safety when the junction temperature is larger than 140°C.

The bandgap module provides stable reference voltage, whose temperature coefficient is compensated by careful design considerations. The temperature coefficient is under 100 ppm/°C. And the accuracy of output voltage is guaranteed by trimming technique.

### Typical Application

has an adjustable version and six fixed versions (1.2V, 1.8V, 2.5V, 2.85V , 3.3V and 5V)

#### Fixed Output Voltage Version

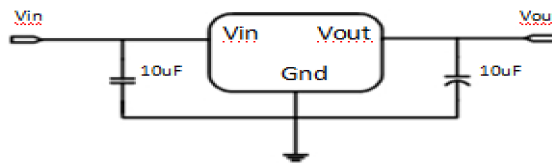

Application circuit of AMS1117 fixed version

- 1) Recommend using 10uF tan capacitor as bypass capacitor (C1) for all application circuit.
- 2) Recommend using 10uF tan capacitor to assure circuit stability.

#### Adjustable Output Voltage Version

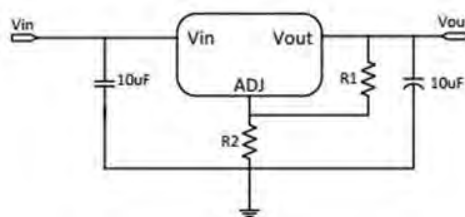

Application Circuit of AMS1117-ADJ

The output voltage of adjustable version follows the equation:  $V_{out} = 1.25 \times (1 + R2/R1) + I_{Adj} \times R2$ . We can ignore  $I_{Adj}$  because  $I_{Adj}$  (about 50uA) is much less than the current of  $R1$  (about 2~10mA).

1) To meet the minimum load current (>10mA) requirement,  $R1$  is recommended to be 125ohm or lower. As AMS1117ADJ can keep itself stable at load current about 2mA,  $R1$  is not allowed to be higher than 625ohm.

2) Using a bypass capacitor ( $C_{ADJ}$ ) between the ADJ pin and ground can improve ripple rejection. This bypass capacitor prevents ripple from being amplified as the output voltage is increased. The impedance of  $C_{ADJ}$  should be less than  $R1$  to prevent ripple from being amplified. As  $R1$  is normally in the range of 100Ω~500Ω, the value of  $C_{ADJ}$  should satisfy this equation:  $1/(2 \pi \times f_{ripple} \times C_{ADJ}) < R1$ .

## 800MA Bipolar Linear Regulator

### Thermal Considerations

We have to take heat dissipation into great consideration when output current or differential voltage of input and output voltage is large. Because in such cases, the power dissipation consumed by AMS1117 is very large. AMS1117 series uses SOT-223 package type and its thermal resistance is about 20°C/W. And the copper area of application board can affect the total thermal resistance. If copper area is 5cm\*5cm (two sides), the resistance is about 30°C/W. So the total thermal resistance is about 20°C/W + 30°C/W. We can decrease total thermal resistance by increasing copper area in application board. When there is no good heat dissipation copper are in PCB, the total thermal resistance will be as high as 120°C/W, then the power dissipation of AMS1117 could allow on itself is less than 1W. And furthermore, AMS1117 will work at junction temperature higher than 125°C under such condition and no lifetime is guaranteed.

### Typical Performance Characteristics

T<sub>A</sub>=25°C, unless otherwise noted.

#### Line regulation

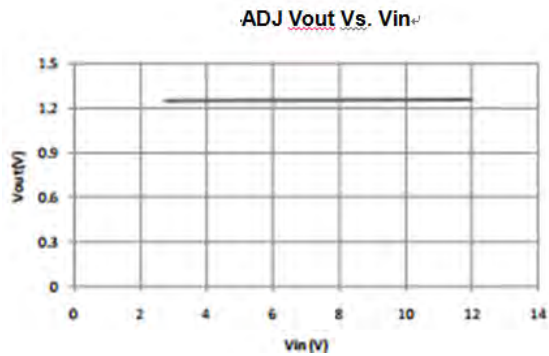

#### Load regulation

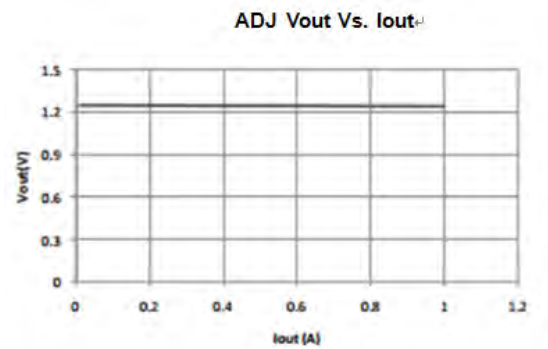

#### Dropout voltage

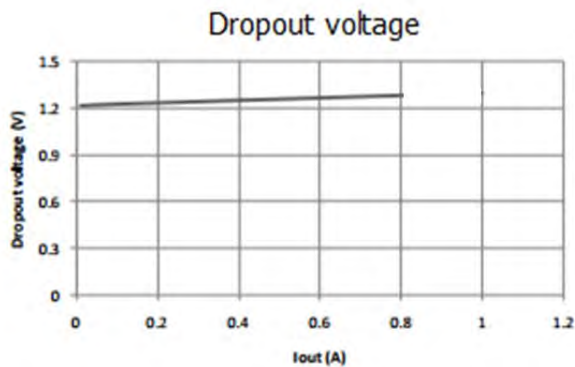

#### Thermal performance with OTP

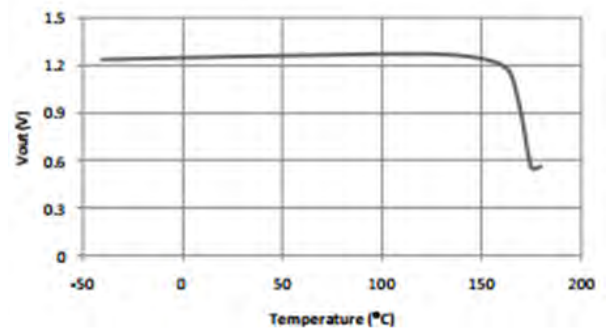

800MA Bipolar Linear Regulator

Package Information

SOT-223 PACKAGE OUTLINE DIMENSIONS

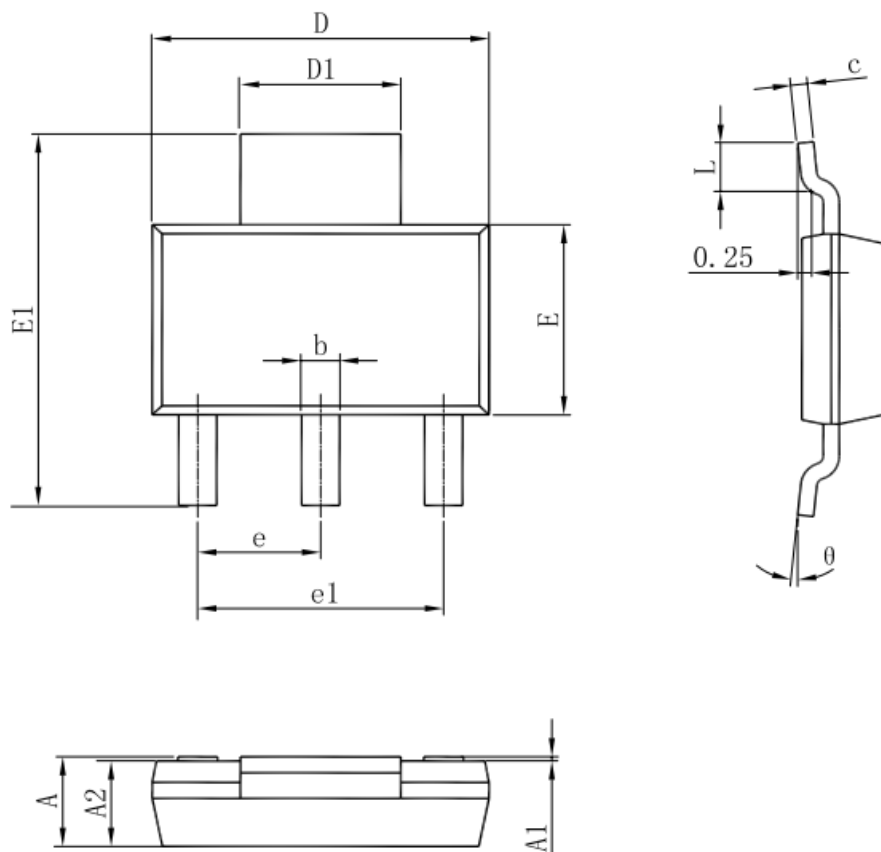

Symbol	Dimensions In Millimeters		Dimensions In Inches	
	Min	Max	Min	Max
A	1.520	1.800	0.060	0.071
A1	0.000	0.100	0.000	0.004
A2	1.500	1.700	0.059	0.067
b	0.660	0.820	0.026	0.032
c	0.250	0.350	0.010	0.014
D	6.200	6.400	0.244	0.252
D1	2.900	3.100	0.114	0.122
E	3.300	3.700	0.130	0.146
E1	6.830	7.070	0.269	0.278
e	2.300(BSC)		0.091(BSC)	
e1	4.500	4.700	0.177	0.185
L	0.900	1.150	0.035	0.045
theta	0°	10°	0°	10°



800MA Bipolar Linear Regulator

TO-252-2L PACKAGE OUTLINE DIMENSIONS

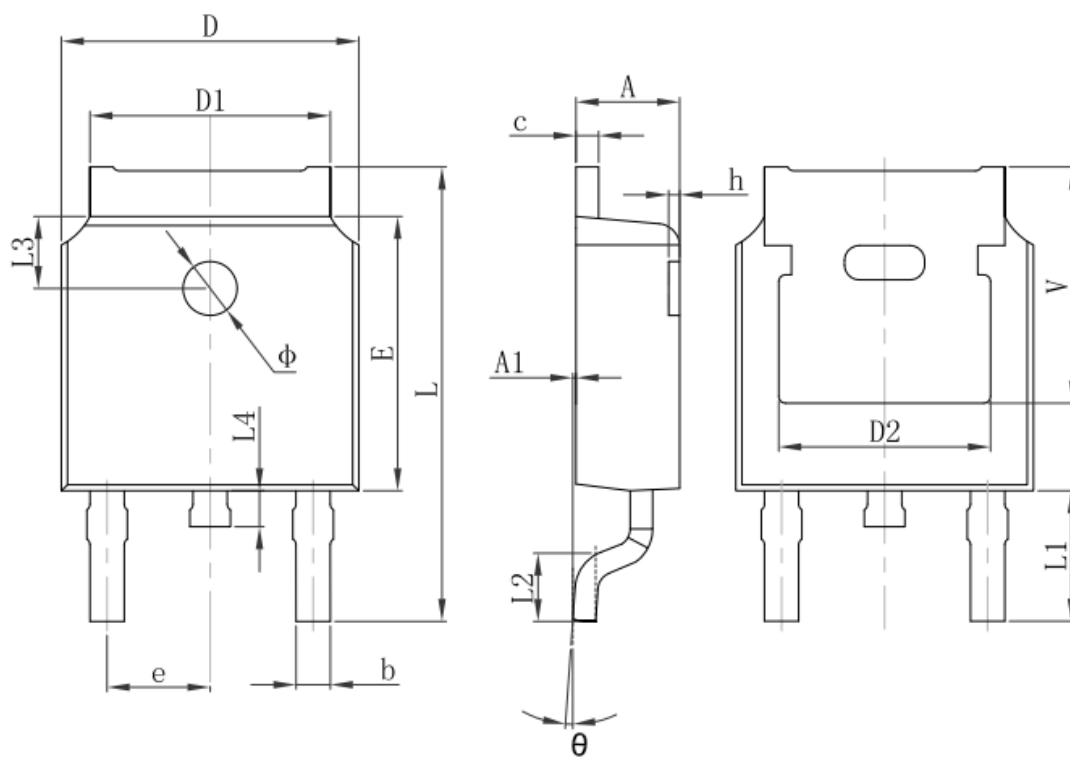

Symbol	Dimensions In Millimeters		Dimensions In Inches	
	Min.	Max.	Min.	Max.
A	2.200	2.400	0.087	0.094
A1	0.000	0.127	0.000	0.005
b	0.660	0.860	0.026	0.034
c	0.460	0.580	0.018	0.023
D	6.500	6.700	0.256	0.264
D1	5.100	5.460	0.201	0.215
D2	4.830 REF.		0.190 REF.	
E	6.000	6.200	0.236	0.244
e	2.186	2.386	0.086	0.094
L	9.800	10.400	0.386	0.409
L1	2.900 REF.		0.114 REF.	
L2	1.400	1.700	0.055	0.067
L3	1.600 REF.		0.063 REF.	
L4	0.600	1.000	0.024	0.039
phi	1.100	1.300	0.043	0.051
theta	0°	8°	0°	8°
h	0.000	0.300	0.000	0.012
V	5.350 REF.		0.211 REF.	

## X-ON Electronics

Largest Supplier of Electrical and Electronic Components

*Click to view similar products for [LDO Voltage Regulators](#) category:*

*Click to view products by [PUOLOP](#) manufacturer:*

Other Similar products are found below :

[AP7363-SP-13](#) [L79M05TL-E](#) [AP7362-HA-7](#) [PT7M8202B12TA5EX](#) [TCR3DF185,LM\(CT](#) [TCR3DF45,LM\(CT](#) [TLE4473G V52](#) [059985X](#)  
[NCP4687DH15T1G](#) [701326R](#) [NCV8170AXV250T2G](#) [AP7315-25W5-7](#) [AP2111H-1.2TRG1](#) [ZLDO1117QK50TC](#) [AZ1117ID-ADJTRG1](#)  
[TCR3DG12,LF](#) [MIC5514-3.3YMT-T5](#) [SCD7912BTG](#) [NCP154MX180270TAG](#) [SCD33269T-5.0G](#) [NCV8170BXV330T2G](#)  
[NCV8170BMX330TCG](#) [NCV8170AMX120TCG](#) [NCP706ABMX300TAG](#) [NCP153MX330180TCG](#) [NCP114BMX075TCG](#) [MC33269T-3.5G](#)  
[TCR3DG33,LF](#) [TCR4DG35,LF](#) [TAR5S15U\(TE85L,F\)](#) [TAR5S18U\(TE85L,F\)](#) [TCR3UG19A,LF](#) [TCR4DG105,LF](#) [MPQ2013AGG-5-P](#)  
[NCV8170AMX360TCG](#) [TLE4268GSXUMA2](#) [NCP715SQ15T2G](#) [MIC5317-3.0YD5-T5](#) [NCV563SQ18T1G](#) [NCP715MX30TBG](#)  
[NCV8702MX25TCG](#) [NCV8170BXV120T2G](#) [MIC5317-1.2YD5-T5](#) [NCV8170AMX150TCG](#) [NCV8170BMX150TCG](#) [AP2213D-3.3TRG1](#)  
[NCV8170BMX120TCG](#) [NCV8170BMX310TCG](#) [NCV8170BMX360TCG](#) [MIC5514-1.2YMT-T5](#)