

L7809

3 TERMINAL 1.5A POSITIVE VOLTAGE REGULATORS

L7809 Three-terminal positive voltage regulator

FEATURES

- Maximum output current
I_{OM}: 1.5 A
- Output voltage
V_O: 9V

1.IN
2.GND
3.OUT

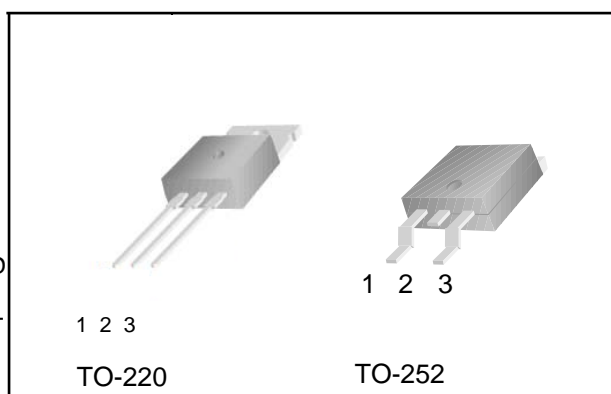

ABSOLUTE MAXIMUM RATINGS (Operating temperature range applies unless otherwise specified)

Parameter	Symbol	Value	Unit
Input Voltage	V _i	35	V
Thermal Resistance from Junction to Air	R _{θJA}	65	°C/W
Operating Junction Temperature Range	T _{OPR}	-20~+125	°C
Storage Temperature Range	T _{STG}	-65~+150	°C

L7809 ELECTRICAL CHARACTERISTICS

(Refer to test circuits, 0<T_j<125°C, I_o=500mA, V_i=15V, C_i=0.33μF, C_o=0.1μF, unless otherwise specified)

Characteristic	Symbol	Test Conditions	Min	Typ	Max	Units
Output voltage	V _o	T _j =25°C	8.65	9.00	9.35	V
		5.0mA<I _o <1.0A, P _D <15W V _i =11.5V to 24V	8.6	9.0	9.4	V
Line regulation	ΔV _o	T _j =25°C, V _i =11.5V to 25V	-	6	180	mV
		T _j =25°C, V _i =12V to 25V	-	2	90	mV
Load regulation	ΔV _o	T _j =25°C, I _o =5.0mA to 1.5A	-	12	180	mV
		T _j =25°C, I _o =250mA to 750mA	-	5	90	mV
Quiescent current	I _q	T _j =25°C	-	5.0	8	mA
Quiescent current change	ΔI _q	I _o =5mA to 1.0A	-	-	0.5	mA
		V _i =12V to 26V	-	-	0.8	mA
Output voltage drift	ΔV _o /ΔT	I _o =5mA	-	1.3	-	mV/°C
Output noise voltage	V _N	f=10Hz to 100kHz, T _a =25°C	-	58	-	μV
Ripple rejection	RR	f=120Hz, V _i =13V to 23V	55	66	-	dB
Dropout voltage	V _o	I _o =1.0A, T _j =25°C	-	2	-	V
Output resistance	R _o	f=1kHz	-	15	-	mΩ
Short circuit current	I _{sc}	V _i =35V, T _a =25°C	-	230	-	mA
peak current	I _{pk}	T _j =25°C	-	2.2	-	A

3 TERMINAL 1.5A POSITIVE VOLTAGE REGULATORS

TEST CIRCUITS

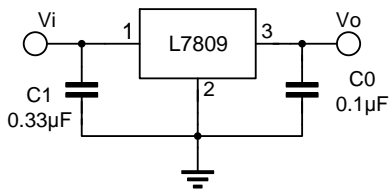

FIG.1 DC PARAMETERS

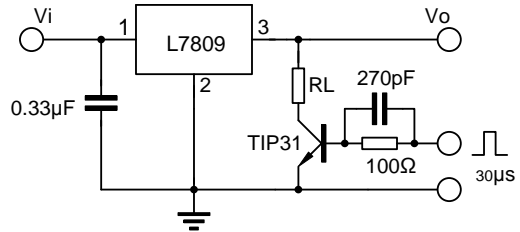

FIG.2 LOAD REGULATION

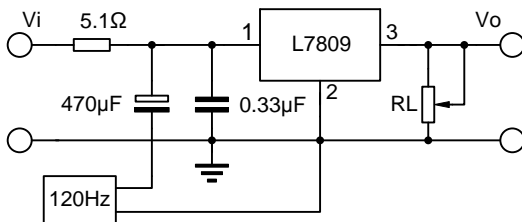

FIG.3 RIPPLE REJECTION

L7809

3 TERMINAL 1.5A POSITIVE VOLTAGE REGULATORS

TO-252 Package Outline Dimensions

Package Outline Dimensions (Units: mm)

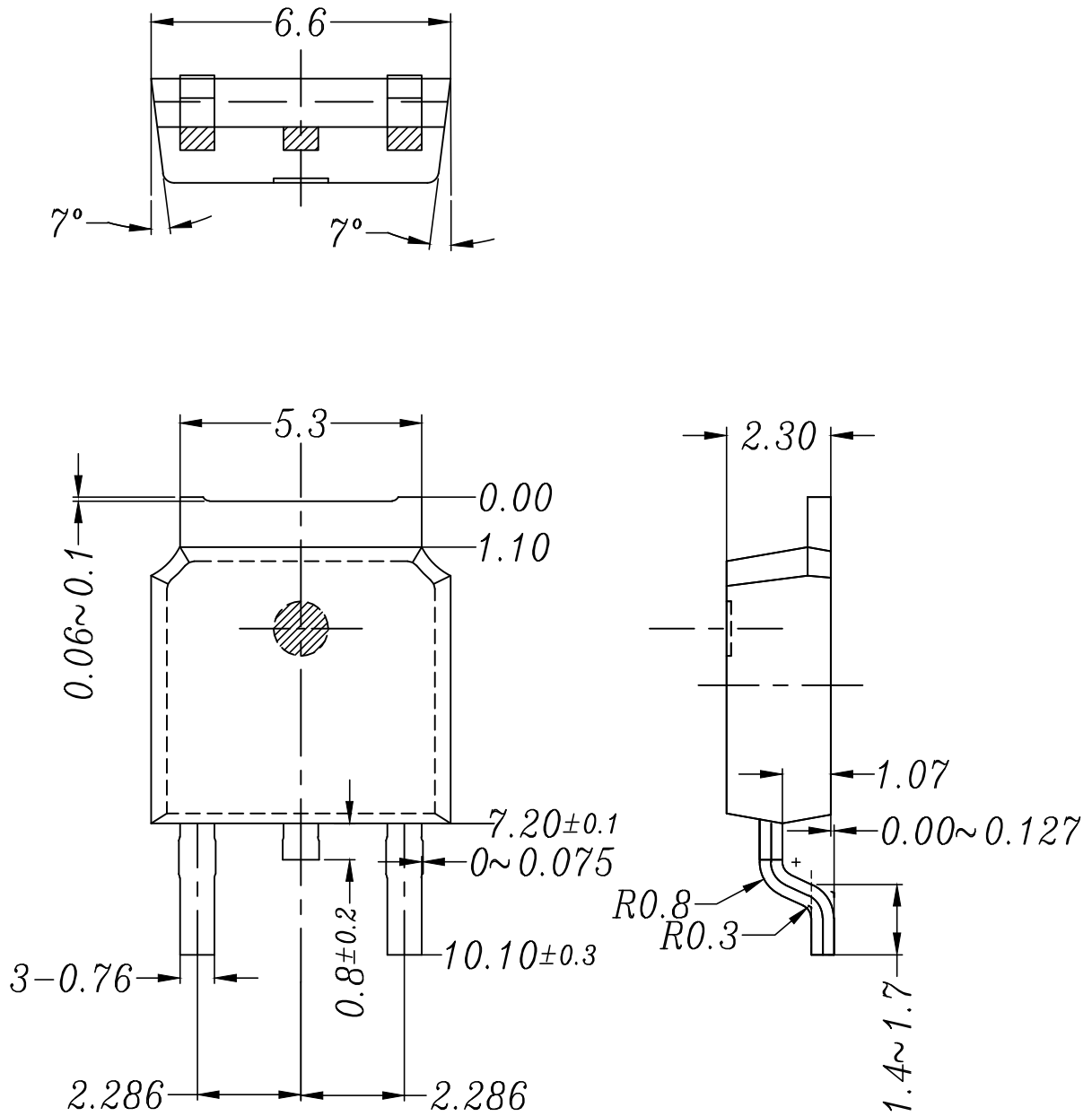

L7809

3 TERMINAL 1.5A POSITIVE VOLTAGE REGULATORS

TO-220 Package Outline Dimensions

Package Outline Dimensions (Units: mm)

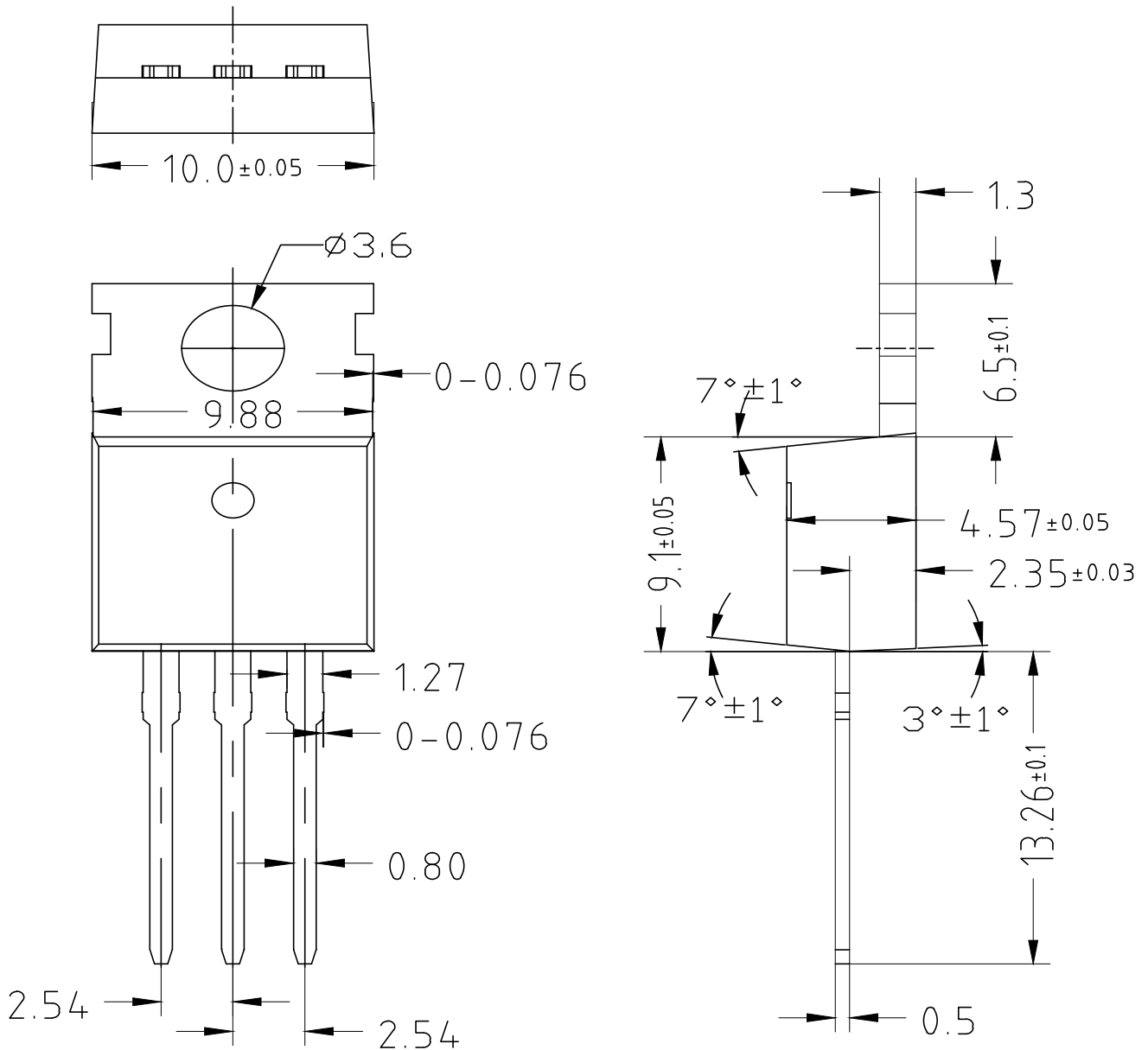

X-ON Electronics

Largest Supplier of Electrical and Electronic Components

Click to view similar products for [Linear Voltage Regulators](#) category:

Click to view products by [PUOLOP](#) manufacturer:

Other Similar products are found below :

[LV5684PVD-XH](#) [MCDTSA6-2R](#) [L7815ACV-DG](#) [714954EB](#) [ZMR500QFTA](#) [BA033LBSG2-TR](#) [LV5680P-E](#) [L79M05T-E](#) [L78LR05D-MA-E](#) [NCV317MBTG](#) [NTE7227](#) [MP2018GZD-33-P](#) [MP2018GZD-5-P](#) [LV5680NPVC-XH](#) [LT1054CN8](#) [ZTS6538SE](#) [UA78L09CLP](#) [UA78L09CLPR](#) [CAT6221-PPTD-GT3](#) [MC78M09CDTRK](#) [NCV51190MNTAG](#) [78M05](#) [HT7150-1](#) [UM1540DB-18](#) [XC6234H281VR-G](#) [WL2834CA-6/TR](#) [TPL730F33-5TR](#) [TLS850F1TA](#) [V50](#) [TPS549B22RVFR](#) [UM1540DB-33](#) [WL9200P3-50B](#) [WL9100P3-33B](#) [WL9005D4-33](#) [XC6219B152MR](#) [WL2855K33-3/TR](#) [PJ54BM33SE](#) [PJ9500M25SA](#) [MD7218E33PC1](#) [H7533-2PR](#) [SK7812AU](#) [SD1A30](#) [78L33](#) [TP78L33T3](#) [L78L33ACUTR](#) [SK6513ST3A-50](#) [SK6054D4-09](#) [SK6054D4-18](#) [SK6054D4-11](#) [SK6054D4-10](#) [LM79L12F](#)